

#2

ELECTRONICS FIELD CHANGE BULLETIN  
 NAVAL SHIP ENGINEERING CENTER  
 WASHINGTON, D. C. 20360

27-AN/URC-32  
 13-AN/URC-32A  
 10-AN/URC-32B  
 18-KWT-6(8)

INSTALLATION OF STANDBY AND EMITTING STATUS MONITORING RELAYS

NAVSHIPS

(Documentary Package)

TYPE (1) CLASS (0)  
 ESTIMATED MAN HOURS (4)

OPERATIONAL CHANGE ( )  
 NON-OPERATIONAL CHANGE (X)

Prepared by  
 NAVAL SHIP ENGINEERING CENTER  
 NORFOLK DIVISION  
 NAVAL STATION, NORFOLK, VA. 23511

**APPROVAL NOTICE:** Naval Shipyards or repair facilities shall accomplish this field change on equipment affected when authorized by Naval Ship Systems Command and upon allocation of funds by Naval Ship Systems Command or Type Commander, as appropriate.

**EQUIPMENT AFFECTED:** Applicable to all Serial Numbers of AN/URC-32( ) and KWT-6(8) Radio Sets installed aboard ships with AN/SSQ-54 Emission Status Indicator Set.

**PURPOSE:** To provide equipment STANDBY and EMITTING functions to the AN/SSQ-54 Emitter Status Indicator Set.

**PREVIOUS FIELD CHANGES:** No previous field change need be accomplished prior to this field change.

**EFFECT ON NOMENCLATURE:** None

**IDENTIFICATION OF ACCOMPLISHMENT:** The accomplishment of this field change may be identified by the presence of two relays installed on the partition between the Receiver Protective Device and the terminal strip blocks in the J-1007/U Junction Box.

14 October 1968

UNCLASSIFIED

Page 1 (of 14)

14 FEB 1969

## MATERIAL REQUIRED:

Supplied in field change documentary package

Item	Ref. Desig.	Qty.	Description
1		2 ea.	Field Change Bulletin, NAVSHIPS 0967-066-7350
2		2 ea.	Temporary Corrections T-4 to NAVSHIPS 0967-066-7010, Volume 1. (Formerly NAVSHIPS 93285B - Volume 1) NAVSHIPS 0967-066-7013
3		2 ea.	Temporary Corrections T-4 to NAVSHIPS 0967-066-7030, Volume 3. (Formerly NAVSHIPS 93285B, Volume 3) NAVSHIPS 0967-066-7032
4		1 ea.	Field Installation Notification of Completion Card (FINC Card)

## MATERIAL REQUIRED:

To be procured by installing activity

Item	Ref. Desig.	Qty.	Description
1	1K3	1 ea.	Relay with side mounting bracket; DPDT, cont. 3A; 26.5 VDC, 975 ohms; P/N 2B-2111, Mfgr. HI-G, Inc. FSN 9N5945-054-0105. (NOTE: If relay has to be substituted, be sure holding coil does not draw over 30 MA at 28 VDC)
2	1K4	1 ea.	Relay, w/stud mounting; DPDT, cont. 2A; 115 VAC, 60-400 Hz; P/N 2BR-1C-215 Mfgr. HI-G, Inc. FSN 9N5945-848-8864
3			Mounting hardware:
		2 ea.	#4-40X 1/4" SST Pan Head, Phillips screws
		4 ea.	#4 SST Split Lock Washers
		4 ea.	#4-40 SST Plain Hexagon Nuts

Item	Ref. Desig.	Qty.	Description
4			Hook-up wire, No. 20 AWG, Teflon Insulated, as follows:
		1 pc.	Color Black, 10" long
		1 pc.	Color Blue, 12" long
		2 pcs.	Color Blue, 5½" long
			(NOTE: 1 pc. required for option 2. hook-up)
		1 pc.	Color Orange, 12" long
		2 pcs.	Color Orange, 5" long
			(NOTE: 1 pc. required for option 1. hook-up)
		1 pc.	Color Red, 12" long
		1 pc.	Color Red, 5" long
		1 pc.	Color White, 3" long
		1 pc.	Color Black 3½" long
		1 pc.	Color Brown 7" long
		1 pc.	Color Gray, 7½" long
5		9 pcs.	Sleeving (Spaghetti) 3/8" long
			(8 pcs. required for option 1. Relay hook-up)

## TOOLS AND TEST EQUIPMENT:

Required by installing activity

Scale, Metal (or 6" ruler)	Toothpick
Screwdriver, Phillips No. 4	Soldering iron, 47½ watt
Pliers, Longnose 6"	Soldering gun, 125 watt
Pliers, Diagonal 6"	Solder, 60/40 Rosin core
Center Punch, Hand	Multimeter, AN/PSM-4
Drill Motor, ¼"	Technical Manual, NAVSHIPS
Drill Bit, 1/8" (.125)	0967-066-7010, Volume 1
Lacing Twine	(Formerly NAVSHIPS 93285B,
Wirestrippers	Volume 1)

PROCEDURE: (AM-2061/URT Modification)

NOTE: OBSERVE ALL APPLICABLE SAFETY PRECAUTIONS WHILE PERFORMING THIS FIELD CHANGE

1. Remove AC power from the equipment at the main bulkhead power switch and tag.
2. Remove the AM-2061/URT R.F. Amplifier from the AN/URC-32 and place face down on a work bench.
3. Remove the rear cover from the AM-2061/URT.
4. J1, J3 and J6 are mounted on a plate which is secured to the AM-2061/URT Chassis Frame. Remove the three screws which secure this plate to the chassis frame. Retain the screws and washer.
5. Remove the six screws which secure the feed-thru capacitor box to plate on which J1, J3 and J6 are mounted. Retain the screws and washers.
6. Locate feed-thru Capacitor C67. Determine by observation or multimeter that C67 is connected to terminal 5 of J6. Check that there are no other wires connected to C67 or terminal 5 of J6.
7. Refer to figure 1 of this bulletin which is a partial schematic of the AM-2061/URT taken from the main AM-2061/URT schematic in NAVSHIPS 0967-066-7010, Volume 1, Figure 5-99. (Formerly NAVSHIPS 93285-B, Volume 1, Figure 5-99). Figure 1 shows the addition of a lead between feed-thru capacitor C67 and the stationary contact of Relay 2K3.
8. Relay 2K3 is physically located on the rear of the AM-2061/URT Chassis, below the rack hinge Switch, S10. With the multimeter, locate the stationary contact terminal of 2K3 which connects through the coil of 2K2 and feed-thru Capacitor C64 to terminal 8 of J6.
9. Solder the 10" piece of black No. 20 AWG hook-up wire in item 4 of material procured to the stationary contact of 2K3. (NOTE: If the contact terminal is heated with the 47½ watt soldering iron, the terminal hole can be opened with a toothpick. The lead can then be hooked into the hole and soldered without removing Relay 2K3)
10. Route the added lead over to the existing cable harness going to the capacitor feed-thru terminal box. Run the lead up the harness. Connect and solder to feed-thru Capacitor C67.
11. Use the highest resistance scale of the multimeter and determine that there is no continuity between terminals 7 and 8, or terminals 5 and 7 of J6.
12. Switch the multimeter to the RX100 scale. Actuate the swinger on Relay 2K3 with a screwdriver. Resistance between J6 terminals 7 and 8, and 5 and 8 is approximately 500 ohms. Resistance between J6 terminals 5 and 7 is zero ohms.

13. If the preceding checks are okay, lace the added lead into the existing cable harness.

14. Reinstall the capacitor feed-thru terminal box on the plate on which J1, J3 and J6 are mounted. Reinstall the plate on the AM-2061/URT Chassis Frame.

15. Replace the AM-2061/URT Rear Chassis Cover. Do not reinstall the AM-2061/URT in AN/URC-32( ) at this time.

PROCEDURE: (J-1007/U Junction Box Wiring, Relay Mounting and Hook-up)

NOTE: OBSERVE ALL APPLICABLE SAFETY PRECAUTIONS WHILE PERFORMING THIS PORTION OF THE FIELD CHANGE

1. Recheck that the A.C. power has been removed from the equipment at the main bulkhead power switch.

2. Remove the J-1007/U Junction Box dust cover.

3. Refer to Figure 2 of this bulletin. Locate the drill the mounting holes for Relay 1K3 (26.5 VDC) and Relay 1K4 (115 VAC), as per instructions on the figure.

NOTE: BE CAREFUL NOT TO GET ANY DRILL SHAVINGS ETC, LODGED BETWEEN ANY OF THE J-1007/U JUNCTION BOX TERMINALS

4. Use 2 No. 4 lock washers and 2 No. 4-40 nuts in item 3 of Material Procured and mount Relay 1K4, item 2 of Material Procured.

5. Use 2 No. 4-40 X ¼" Pan Head Phillips Screws, 2 No. 4 lock washers, and 2 No. 4-40 nuts in item 3 of Material Procured and mount Relay 1K3, item 1 of Material Procured.

6. The AN/SSQ-54 Status Indicating Equipment will supply a "Signal In" (50 V) to the AN/URC-32( ) which returns the "Signal In" to the AN/SSQ-54 as "STANDBY" or "RADIATE" condition signals. Refer to Figure 3 and determine which relay hook-up the installation requires.

a. Option 1 relay hook-up will apply 50 volts out on the ORANGE STANDBY line when the AN/URC-32( )'s power switch "S1" on the low voltage power supply is placed in the "ON" position. When the "PLATE ON-OFF KEY" switch on the AM-2061/URT is placed in the "ON" position with the "FIL-OFF-TUNE/OPERATE" switch in either "TUNE" or "OPERATE" and the AN/URC-32( ) is keyed, 50 volts will be applied to the red radiate line also. A radiate

condition will be indicated by the presence of 50 volts on both the orange and red lines simultaneously.

b. Option 2 relay hook-up will apply 50 volts out on the orange standby line when power switch "S1" on the low voltage power supply is placed in the "ON" position. When the "PLATE ON-OFF KEY" switch on the AM-2061/URT is placed in the "ON" position with the "FIL OFF-TUNE/OPERATE" switch in either "TUNE" or "OPERATE" and the AN/URC-32( ) is keyed. The 50 volts on the orange line will be switched to the red radiate line. A radiate condition will be indicated by the presence of 50 volts on only the red line. Standby is indicated by the presence of 50 volts on the orange line only.

c. The emission status indicating equipment's circuitry will determine whether 50 volts is required on both the orange and red lines simultaneously to indicate a radiate condition, or whether 50 volts is required on just the red line to indicate a radiate condition.

d. After determining which relay hook-up the installation requires, refer to Figure 4 for Option 1 Relay Hook-Up, or refer to Figure 5 for Option 2 Relay Hook-Up. Junction Box, J-1007/U wiring is the same for either option.

7. Make the relay hook-ups and J-1007/U Junction Box wiring connections as indicated in either Figure 4 or 5. On each wiring connection to the terminals of 1K3 and 1K4 slip a piece of sleeving over the lead before making the connection. After soldering, slip the sleeving over the soldered terminal connections.

NOTE: USE THE 47½ WATT SOLDERING IRON TO MAKE THE CONNECTIONS TO THE RELAY TERMINALS. USE THE 125 WATT SOLDERING GUN TO MAKE THE J-1007/U JUNCTION BOX TERMINAL CONNECTIONS. IT IS POSSIBLE THAT SOME OF THE WIRING COLORS MAY HAVE TO BE SUBSTITUTED. MAKE EVERY EFFORT TO MAINTAIN THE LEAD COLORS AS INDICATED ON FIGURE 4 OR 5. PARTICULARLY THE BLUE, ORANGE AND RED LEADS.

8. After completion of the J-1007/U Junction Box wiring and relay hook-up, reinstall the AM-2061/URT in the AN/URC-32( ) electrical equipment rack and reconnect all cables and plugs to the unit.

9. Return power to the AN/URC-32( ) at the main bulkhead power switch.

10. Check-out the J-1007/U Junction Box wiring and relay hook-ups as follows:

OPTION 1 or 2 Relay Hook-Up and J-1007/U wiring check.

a. Check that S1 on the low voltage power supply is in the "OFF" position.

b. Use the AN/PSM-4 and determine that 115 VAC is not present across the coil of Relay 1K4.

c. Check that the AN/URC-32( ) is unkeyed. "EXCITER R.F. GAIN" control is maximum CCW, "PLATE ON-OFF KEY" switch on the AM-2061/URT is in the "OFF" position, and "FIL OFF TUNE/OPERATE" switch is in either the "TUNE" or "OPERATE" position.

d. Connect the AN/PSM-4 across the J-1007/U Junction Box terminals S-18 and S-19. No continuity should be indicated. Position "S1" on the low voltage power supply to the "ON" position. Approximately zero ohms should now be indicated on the AN/PSM-4, set to the RX1 scale.

e. Connect the AN/PSM-4 across the J-1007/U terminals S-18 and S-20. No continuity should be indicated on the AN/PSM-4.

f. Place the "PLATE-ON-OFF KEY" switch on the AM-2061/URT to the "ON" position. No continuity is still indicated on the AN/PSM-4 between J-1007/U terminals S-18 and S-20.

g. Key the AN/URC-32. Approximately zero ohms should now be indicated between J-1007/U Terminals S-18 and S-20.

h. With "PLATE ON-OFF KEY" switch still in the "ON" position and the AN/URC-32( ) keyed, recheck continuity between J-1007/U terminals S-18 and S-19. Approximately zero ohms should also be indicated if OPTION 1 wiring and relay hook-up were used. If OPTION 2 wiring and relay hook-up was used, resistance between J-1007/U terminals S-18 and S-19 should be Infinity.

11. If all checks are okay, the AN/URC-32( ) is now ready for connection to the AN/SSQ-54 status indicator equipment, or other type status indicating equipment.

12. If the cable from the status indicating equipment is available in the compartment space at this time (or when it is available) the cable should be routed to the rear left side of the AN/URC-32( )'s J-1007/U Junction Box, (Left facing front of Radio Set), then down beside terminal strip "A" to terminals A18, A19 and A20. There should be three active leads in the cable, any spares should be cut back and taped. The cable should be connected as follows:

Signal in Lead - - (50 V from AN/SSQ-54 status indicating equipment)  
Connect and solder to the J-1007/U Terminal, A-18

Standby Signal Out Lead - - Connect and solder to the J-1007/U Terminal, A-19

Radiate Signal Out Lead - - Connect and solder to the J-1007/U Terminal, A-20

Lace cable to tie bar behind J-1007/U Junction Box, or clamp to AN/URC-32( ) rack to provide strain relief.

13. Operate the AN/URC-32 and check that the "Amber" light at the emission status board lights when the AN/URC-32( ) is energized, and that the "Red" radiate light lights when the AN/URC-32( ) is in a "Radiate" condition. When the "Red" light is on the "Amber" light should be off, if the status circuitry in the AN/SSQ-54, or other status indicating equipment, is functioning properly, and the cable connections at S-18, S-19, and S-20 have been connected properly.

14. Replace the J-1007/U Junction Box Dust Cover and return equipment to normal operation.

#### ROUTINE INSTRUCTIONS:

1. Corrections to publications and charts.

a. Maintenance support activities shall make the corrections or replacements immediately, but shall keep the superseded data in the book for equipments that have not been modified. Holders of equipment shall not make these corrections or replacements until after the field change has been accomplished.

2. Record of accomplishment: Personnel accomplishing this field change shall record its completion on the Field Change Accomplishment Plate, FSN 1-0264-085-0000, and on the Record of Field Changes Card NAVSHIPS 537 if MDCS has not been implemented. If MDCS is implemented, record completion on the Field Change Accomplishment Plate and on the appropriate shipboard maintenance action form in accordance with OPNAV 43P2 using EQUIPMENT IDENTIFICATION CODE (EIC) numbers 32-FH43000, 32A-FH44000, 32B-FH45000 and KWT-6-FH43000.

3. Disposition of replaced material. No material is replaced in the accomplishment of this change.



4. Disposition of field change bulletin. Maintenance support activities shall maintain a library copy of this field change bulletin. Holders of equipment shall not destroy this field change bulletin until the field change has been accomplished, the equipment tested, and the applicable manuals corrected.

P/O  
J6

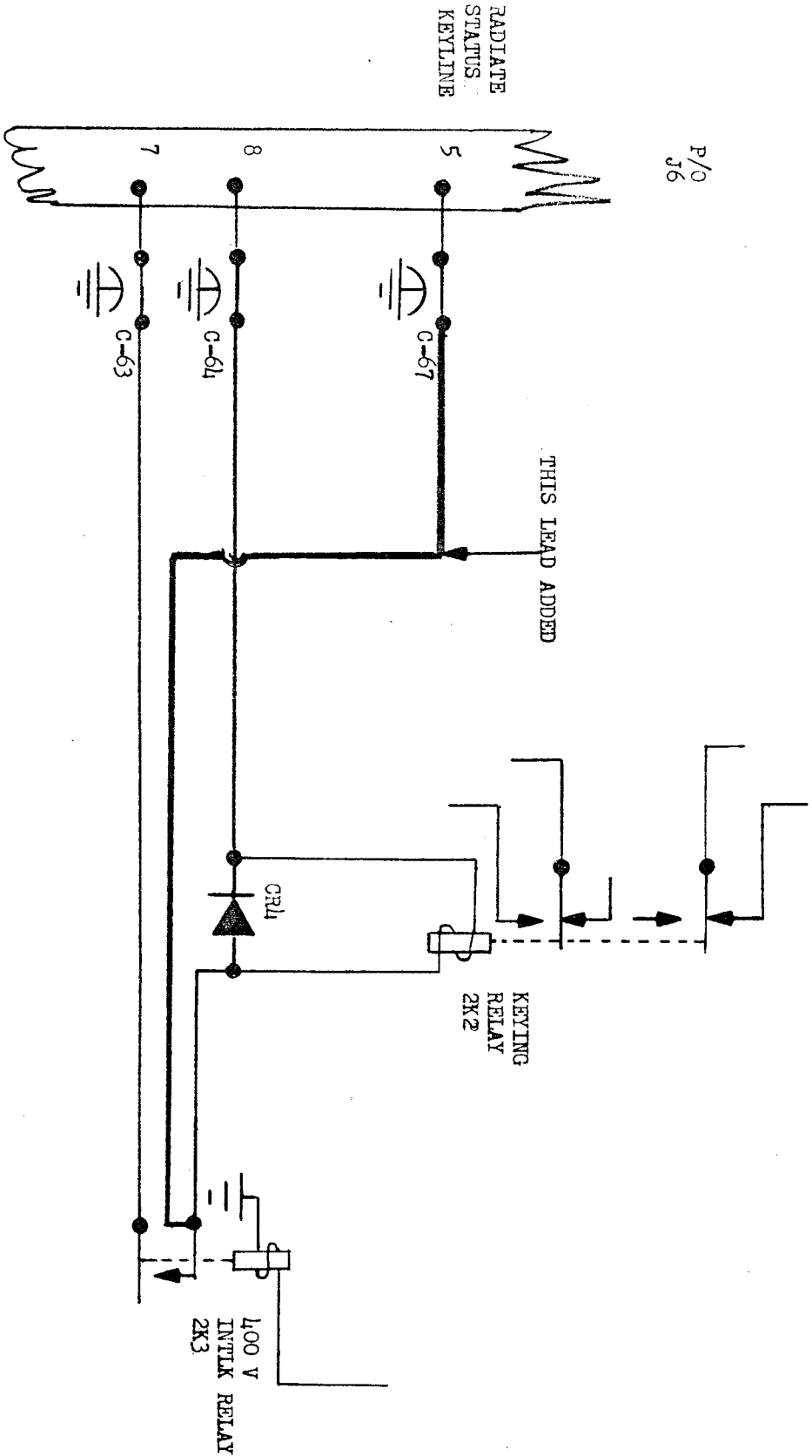

AM-2061/URT WIRING MODIFICATION

FIGURE 1.

- 27-AW/000-32
- 13-AW/000-32A
- 10-AW/000-32B
- 16-KMT-6(9)

PARTITION BETWEEN JUNCTION BOX TERMINALS AND RECEIVER PROTECTIVE DEVICE.

LOCATE RELAY MOUNTING HOLES AS INDICATED ON UPPER REAR SECTION OF THIS PARTITION.

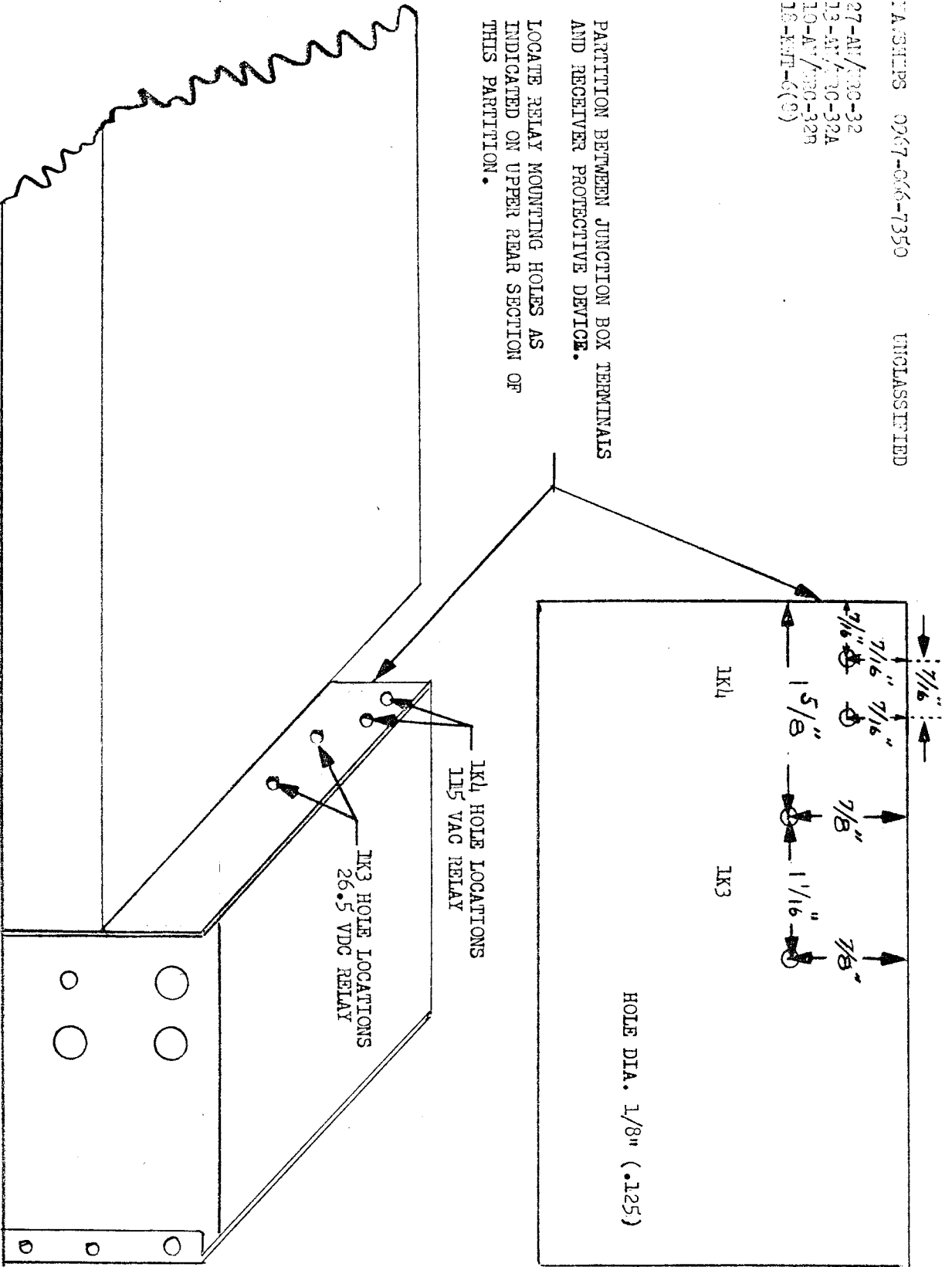

J-1007/U JUNCTION BOX -- RELAY MOUNTING HOLES LOCATION

FIGURE 2.

11 OCTOBER 1968

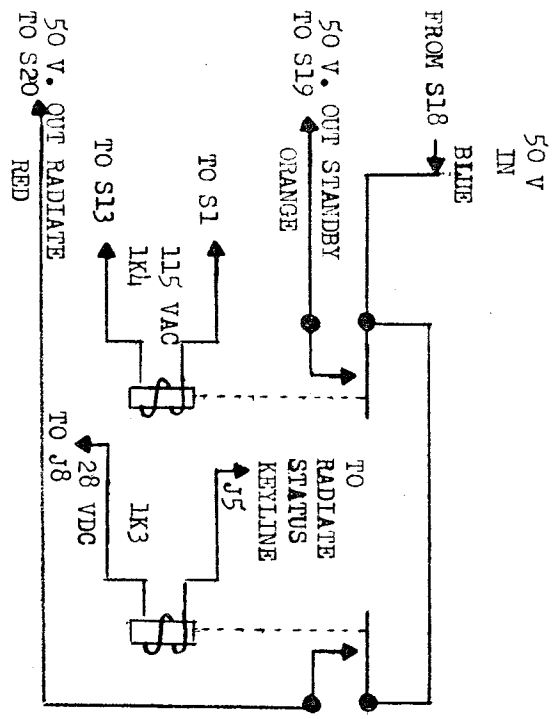

STANDBY - 50 V. OUT ON ORANGE LEAD ONLY.

RADIATE - 50 V. OUT ON BOTH THE ORANGE AND RED LEADS SIMULTANEOUSLY.

OPTION 1.

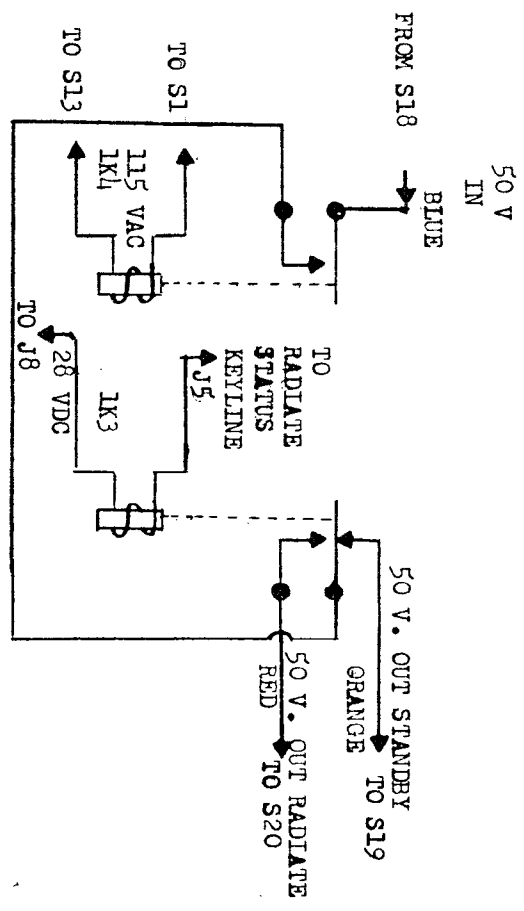

STANDBY - 50 V. OUT ON ORANGE LEAD ONLY.

RADIATE - 50 V. OUT ON RED LEAD ONLY.

OPTION 2.

RELAY HOOK-UP  
WIRING OPTIONS

FIGURE 3.

NAVSHIPS 0967-066-7350

UNCLASSIFIED

27-AH/URC-32  
29-AH/URC-32A  
10-AH/URC-32B  
18-KWT-6(8)

FIGURE 4.

OPTION 1.

J-1007/U JUNCTION BOX, TERMINAL WIRING AND RELAY HOOK-UP

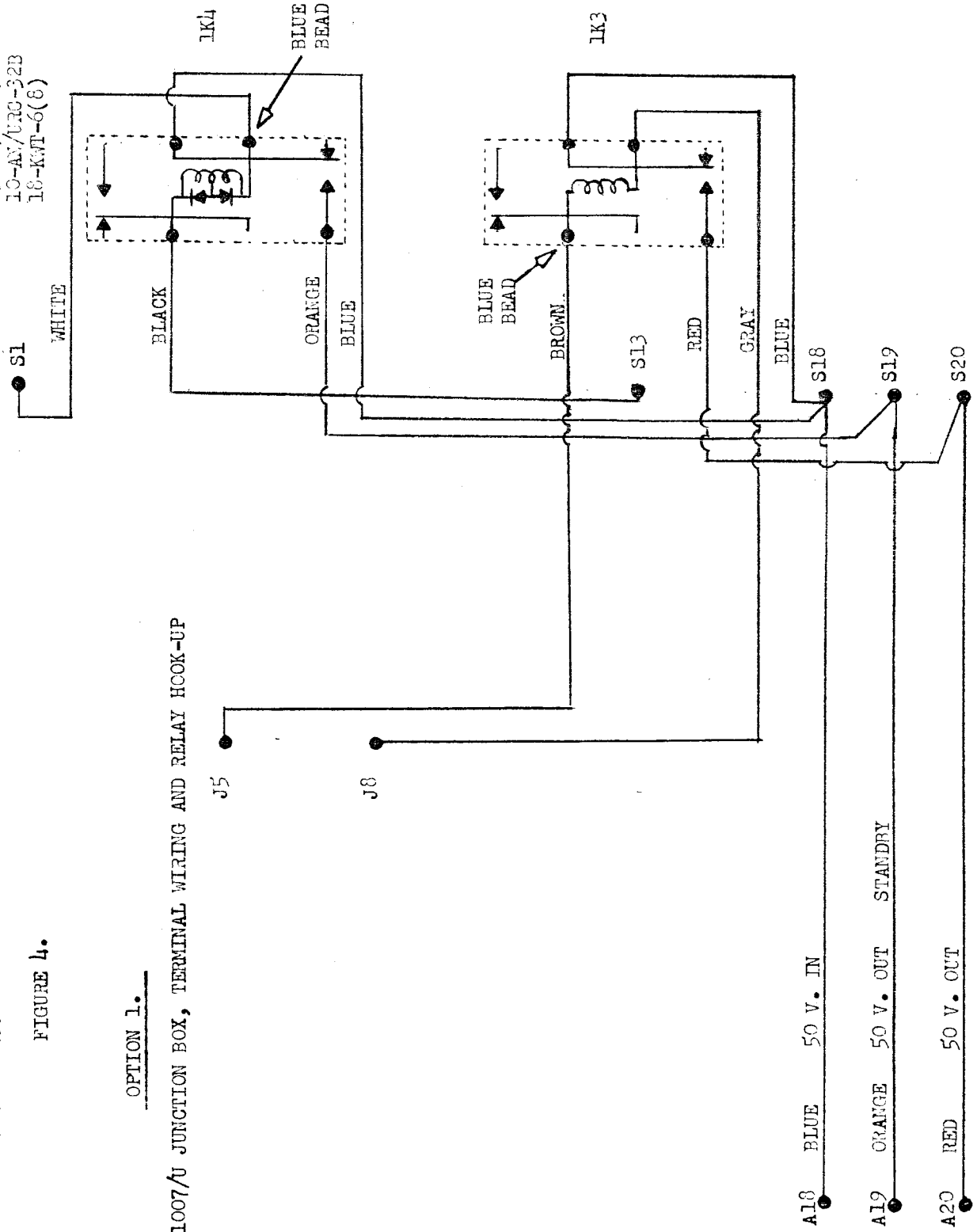

NAVSHIPS 0447-016-7350

UNCLASSIFIED

27-AN/URC-32  
13-AN/URC-32A  
10-AN/URC-32B  
1C-KWT-0(0)

FIGURE 5.

OPTION 2.

J-1007/U JUNCTION BOX, TERMINAL WIRING AND RELAY J5  
HOOK-UP.

