

TELETYPEWRITER SELECTOR MECHANISMS

14, 15, AND 20 TELETYPEWRITERS

REQUIREMENTS AND ADJUSTMENTS

CONTENTS	PAGE	1. GENERAL
1. GENERAL . . . . .	1	1.01 This section contains the requirements and adjustments for the maintenance of the selector mechanisms (holding magnet and pulling magnet) used on the 14, 15, and 20 teletypewriter apparatus listed in 1.03 of this section.
2. REQUIREMENTS AND ADJUSTMENTS . . . . .	1	1.02 This section is reissued to bring the section generally up to date.
Holding-magnet		1.03 The requirements and procedures of this section may be applied in full or in part to the following units:
Armature . . . . .	8	Typing Unit: 14, 15, and 20
Armature lever . . . . .	7, 10	Reperforator: 14 and 20
Armature-lever spring . . . . .	11	Reperforator-transmitter: 14
Locking lever . . . . .	9	Typing Reperforator: 14
Locking-lever spring . . . . .	9	Sequential Selector (SOTUS)
Locking wedge . . . . .	9	
Magnet bracket . . . . .	11	1.04 Whenever an adjustment refers to a No. 1 sword or selector lever, the parts referred to are those which are associated with the selector cam directly adjacent to the selector-cam-sleeve stoparm. However, because of differences in the apparatus, those parts are not designated No. 1 on all the units. In the 14 and 15 teletypewriters, 14 reperforator-transmitters, the cam and associated parts are designated No. 1, in the 20 teletypewriter No. 0, and in the 14 and 20 reperforators No. 5.
Selector arm . . . . .	8	1.05 Although an adjustment refers to a No. 1 sword or selector lever, the foregoing should be considered when the adjustment is to be applied to a unit for which the parts are otherwise designated.
Selector-arm spring . . . . .	11	
Selector-arm stop-detent spring . . . . .	10	
Selector cams . . . . .	7	
Selector-lever spring . . . . .	2	
Swords . . . . .	9	
Sword separator-plate leaf springs . . . . .	1	
Pulling-magnet Type		2. REQUIREMENTS AND ADJUSTMENTS
Armature . . . . .	14	Note: Remove range-finder assembly.
Armature-detent mounting bracket (20-type) . . . . .	18	2.01 <u>Sword Separator-plate Leaf Springs</u> except those of top and bottom plates, should press lightly against their respective swords.
Armature-detent spring (20-type) . . . . .	19	
Armature-locking-lever spring . . . . .	18	
Armature-locking wedge . . . . .	17	
Armature spring . . . . .	17	
Magnet bracket . . . . .	18	
No. 1 sword arms . . . . .	17	
Selector-lever spring . . . . .	2	
Selector cams . . . . .	7	
Swords . . . . .	14	
Sword separator-plate leaf springs . . . . .	1	
Range-finder Mechanism		
Armature tripoff screw . . . . .	20	
Range-finder positioning link . . . . .	20	
Stoplever . . . . .	19	
Stoplever spring . . . . .	20	
Selector-clutch torque . . . . .	2	
Triplatch spring . . . . .	19	

**To Check:** Remove the separator plates and check to see that the leaf-spring end is minimum 0.050 inch, maximum 0.060 inch away from the plane of the plate. Gauge by eye. Use care to avoid distorting the selector-lever springs. Return the swords and selector levers to their original positions.

**To Adjust:** Bend the leaf spring at the narrow part. (See Figure 1.)

**Note:** On six-unit reperforators that drop the fifth marking impulse, it may be necessary to bend the leaf of the separator plate for the No. 5 sword so that it exerts a force of minimum 4-1/4 ounces, maximum 4-3/4 ounces when measured as follows:

(a) With the separator plate resting on a flat, horizontal surface, and with the leaf pointing upward, apply a scale to the edge of the leaf and push down vertically. It should require minimum 4-1/4 ounces, maximum 4-3/4 ounces to press the leaf down until the end just touches the flat surface.

(b) On units having the leaf of the separator plate bent in accordance with the foregoing, the No. 4 and No. 5 selector-lever spring tension should not exceed 3-1/2 ounces and 4-1/2 ounces respectively. See 2.02(b).

## 2.02 Selector-lever Spring:

(a) 14, 15, and 20 typing units, 14 reperforator-transmitters, 14 typing reperforator, sequential selector (SOTUS). With the codebars in the marking position, the mainbail in its

extreme forward position (main shaft mounted horizontally) or highest position (main shaft mounted vertically) and the swords moved manually to the spacing position, hook a scale over the end of a selector lever at the selector camsleeve and pull radially to the main shaft. It should require minimum 6 ounces, maximum 10 ounces as indicated in Figure 2 (holding magnet) and Figure 3 (pulling magnet), to start the lever moving. Check all selector levers in the same manner.

(b) 14 and 20 Reperforators: Rotate the main shaft until the selector camsleeve is in its stopped position. With the transfer levers in the spacing position, hook a scale over the top of the No. 5 transfer lever and pull horizontally to the right. It should require minimum 1-1/2 ounces, maximum 3 ounces to move the lever to the spacing position. The lever should start back at not less than 1/2 ounce. Check all transfer levers in the same manner. See 2.01 (Note).

**To Adjust:** Bend leaf spring at narrow part.

2.03 Selector-clutch Torque: After the felt friction washers have been freshly lubricated and the main shaft has rotated for at least ten minutes, hook a scale over the end of the selector-camsleeve stoparm. It should require minimum 14 ounces, maximum 18 ounces to hold the selector camsleeve stationary when the selector stoparm is held just clear of its stop.

**To Adjust:**

(1) On units equipped with the new-style capstan nut, keyed nut, and spacer (see Figure 4 for parts) hold the capstan nut

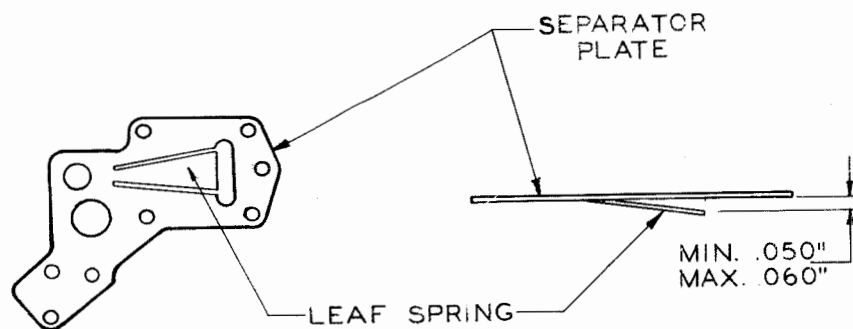

Figure 1

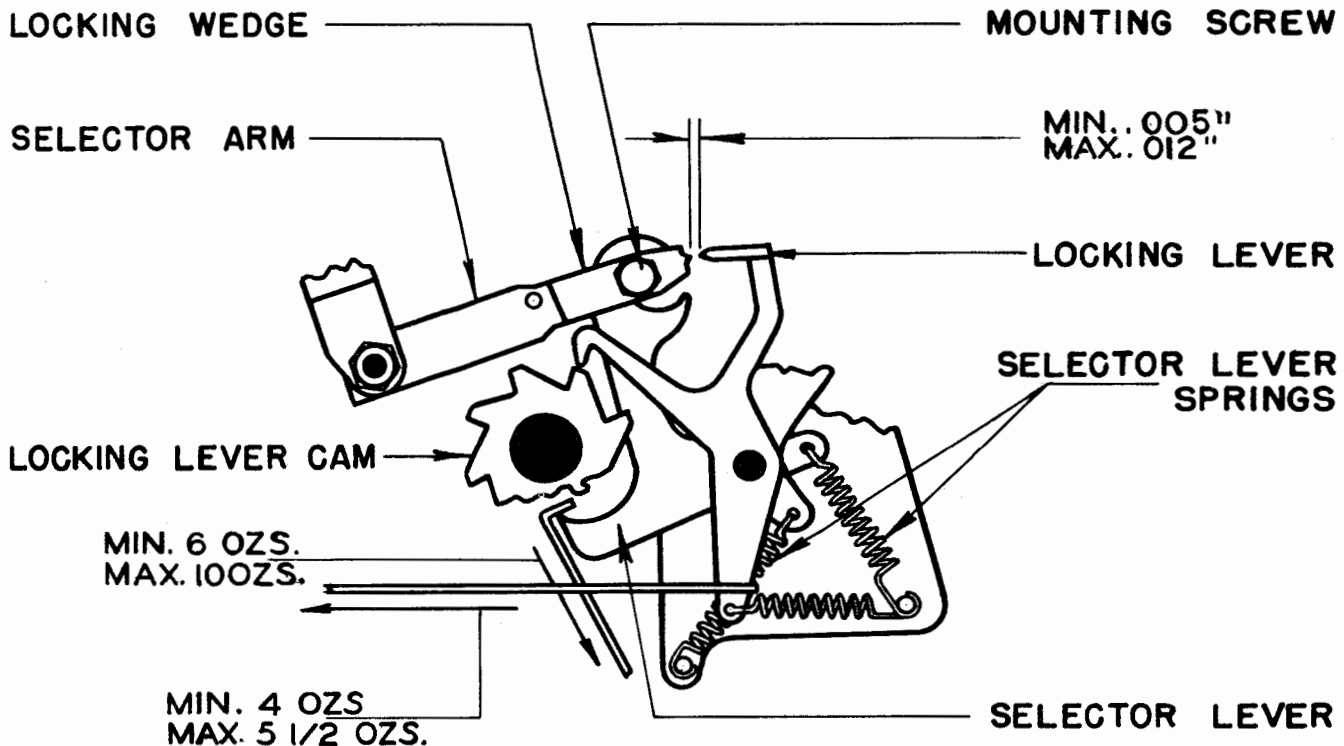

Figure 2

stationary and rotate the main shaft clockwise, viewed from the selector end of the shaft, to increase the torque and counter-clockwise to decrease the torque. See Figure 4 for parts.

(2) On units equipped with the old-style nut and keyed nut, add shims between the clutch spring and the nut to increase the torque and remove shims to decrease the torque. The selector-clutch spring must be removed from the shaft to install or remove shims. Shims are available as follows: See Figure 5 for parts.

<u>Shim</u>	<u>Thickness</u>
TP96763	0.012 inch
TP96764	0.016 inch
TP96765	0.020 inch

**Note:** For convenience of future adjustments, consideration should be given to replacing the old-style nut and keyed nut with the new-style capstan nut, keyed nut, and spacer.

(3) If the torque cannot be met by the adjustments of (1) or (2), replace the felt friction washers. Replace all TP6861 felt friction washers with TP122741 colloidal-graphite impregnated felt friction washers.

**CAUTION:** AVOID GETTING DIRT OR METAL CHIPS ON WASHERS OR ON BEARING SURFACES.

(4) To replace felt friction washers: [ For SOTUS unit see note following step (6) ]

(a) Remove the range-finder assembly, detach the locking-lever spring and remove the retaining disc, noting that it has a left-hand thread and unscrews to the right (clockwise).

(b) Remove the outer felt washer, cam-sleeve disc, camsleeve assembly, camsleeve disc, and the inner felt washer. Remove the second camsleeve disc by holding the selector levers away from the shaft and rotating the camsleeve disc until the notch in its edge registers with the points of the selector levers.

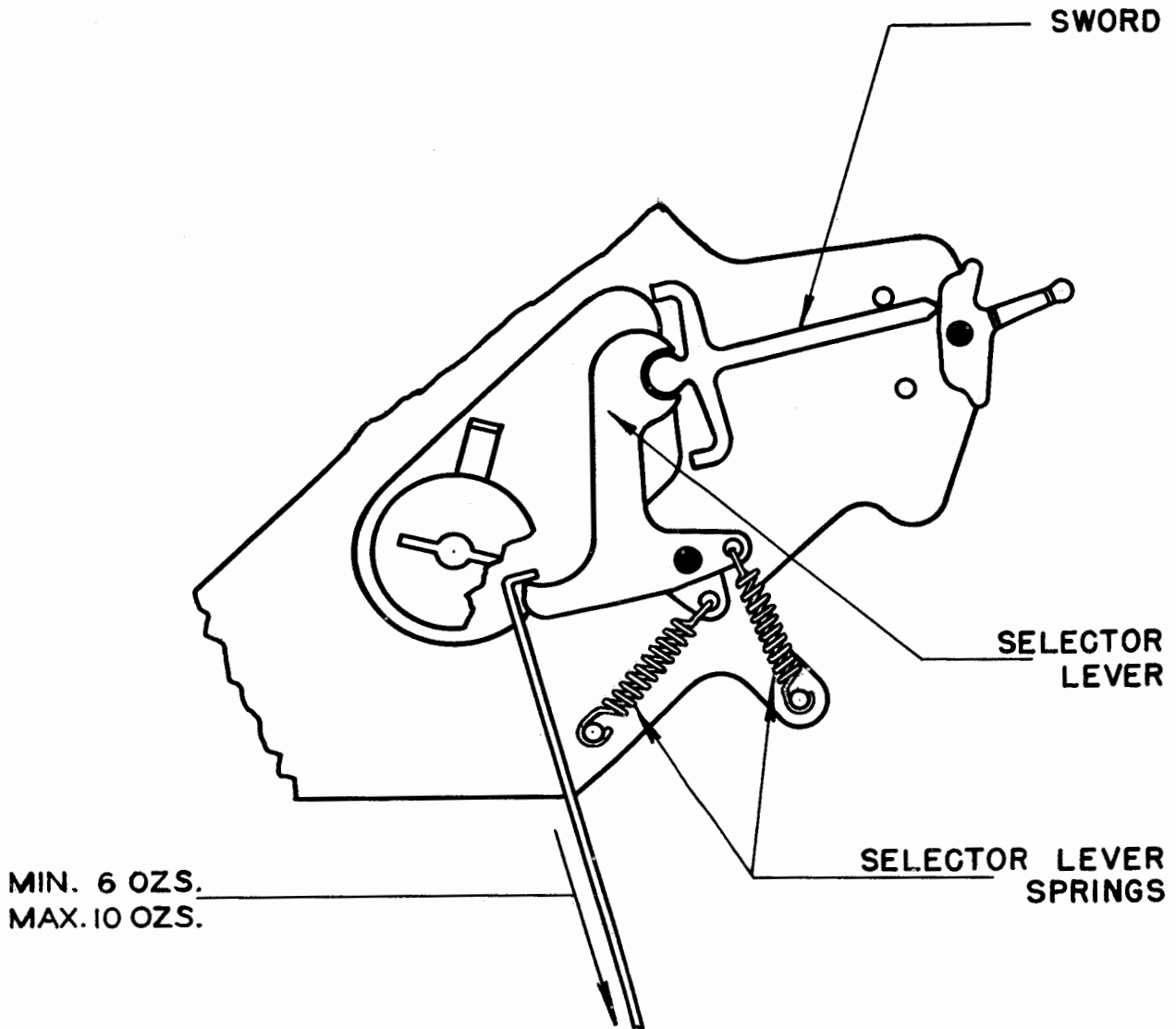

Figure 3

- (5) If those procedures do not meet the requirements, change the friction-clutch spring.
- (6) To add shims or to change the nuts or the clutch spring: [ For SOTUS see note following (b)]
  - (a) Proceed as in (3).
  - (b) Remove main selector-clutch driving disc and spring.

**Note:** For the SOTUS unit, the following procedures replace the above steps. These procedures cover partial removal of the main shaft and do not require disturbing the selector-mechanism assembly.

- (7) For the SOTUS, the following replaces steps (4) and (6):
  - (a) Remove the timer sensing-bail mounting screw and allow the sensing-bail to hang out of the way. (See Figure 6.)
  - (b) Remove the range finder.
  - (c) Remove the outer friction-washer disc from the main shaft by applying a screwdriver to the slot in the disc and turning in a clockwise direction while holding the main shaft. (See Figure 6.)

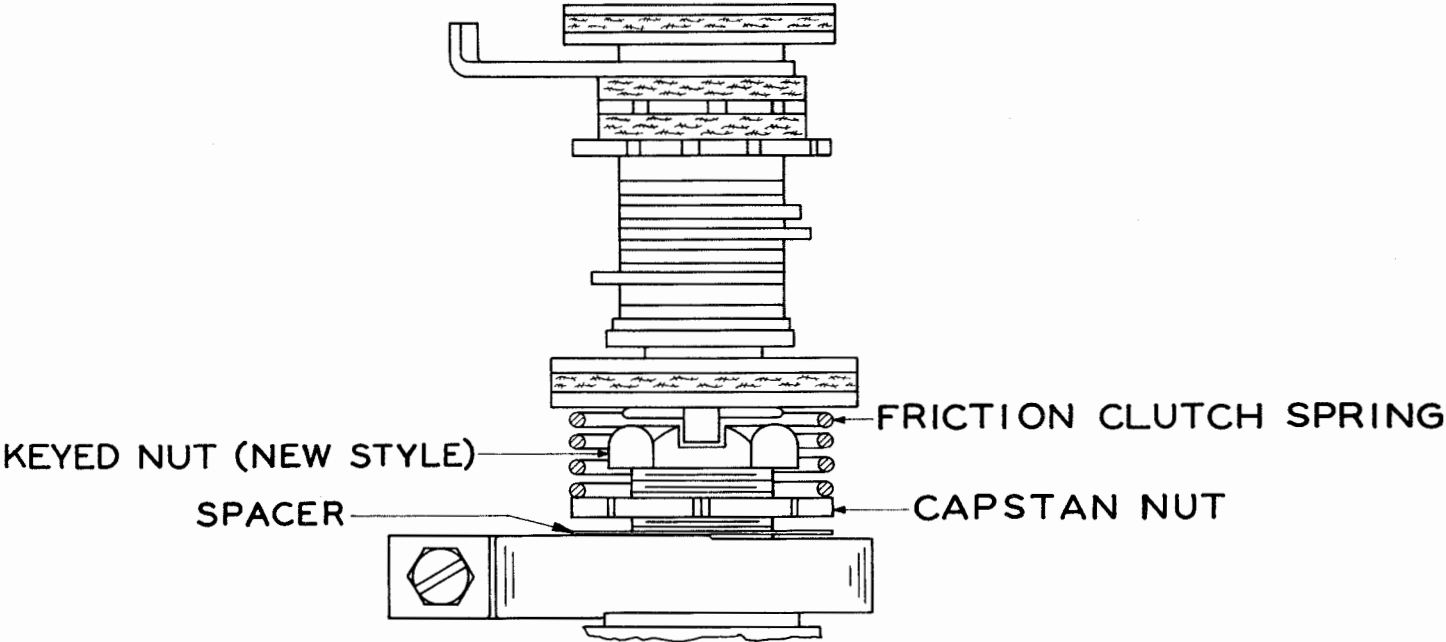

Figure 4

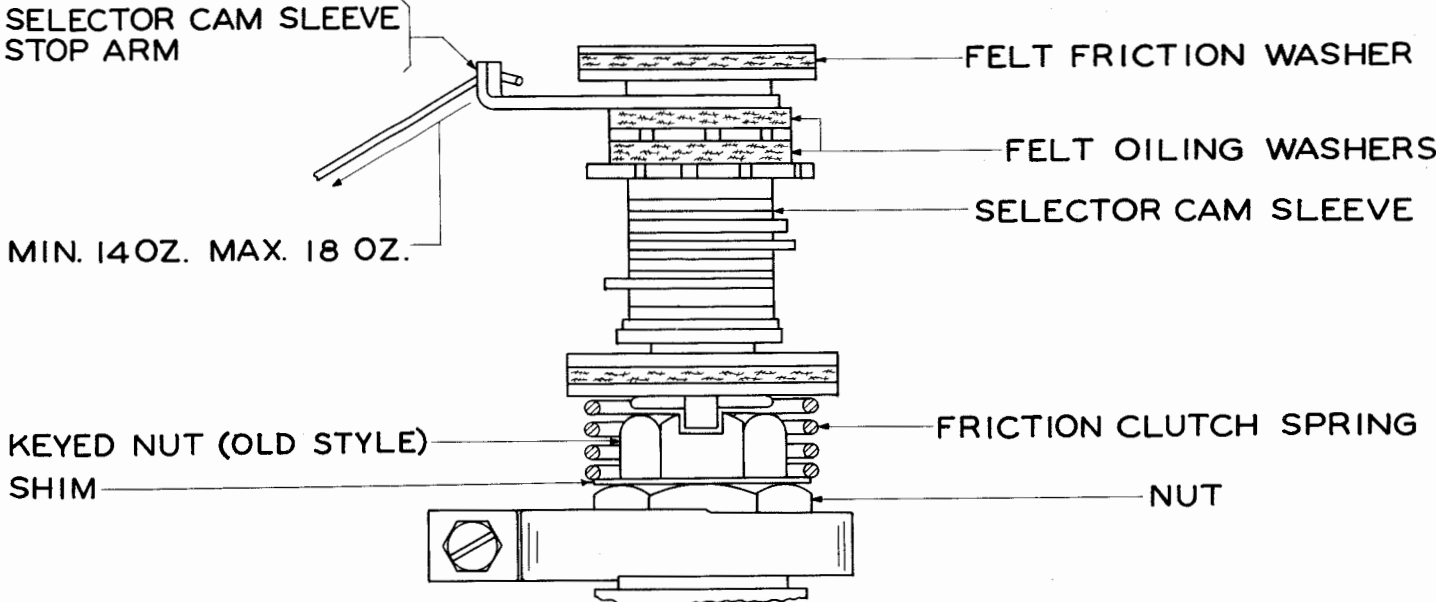

Figure 5

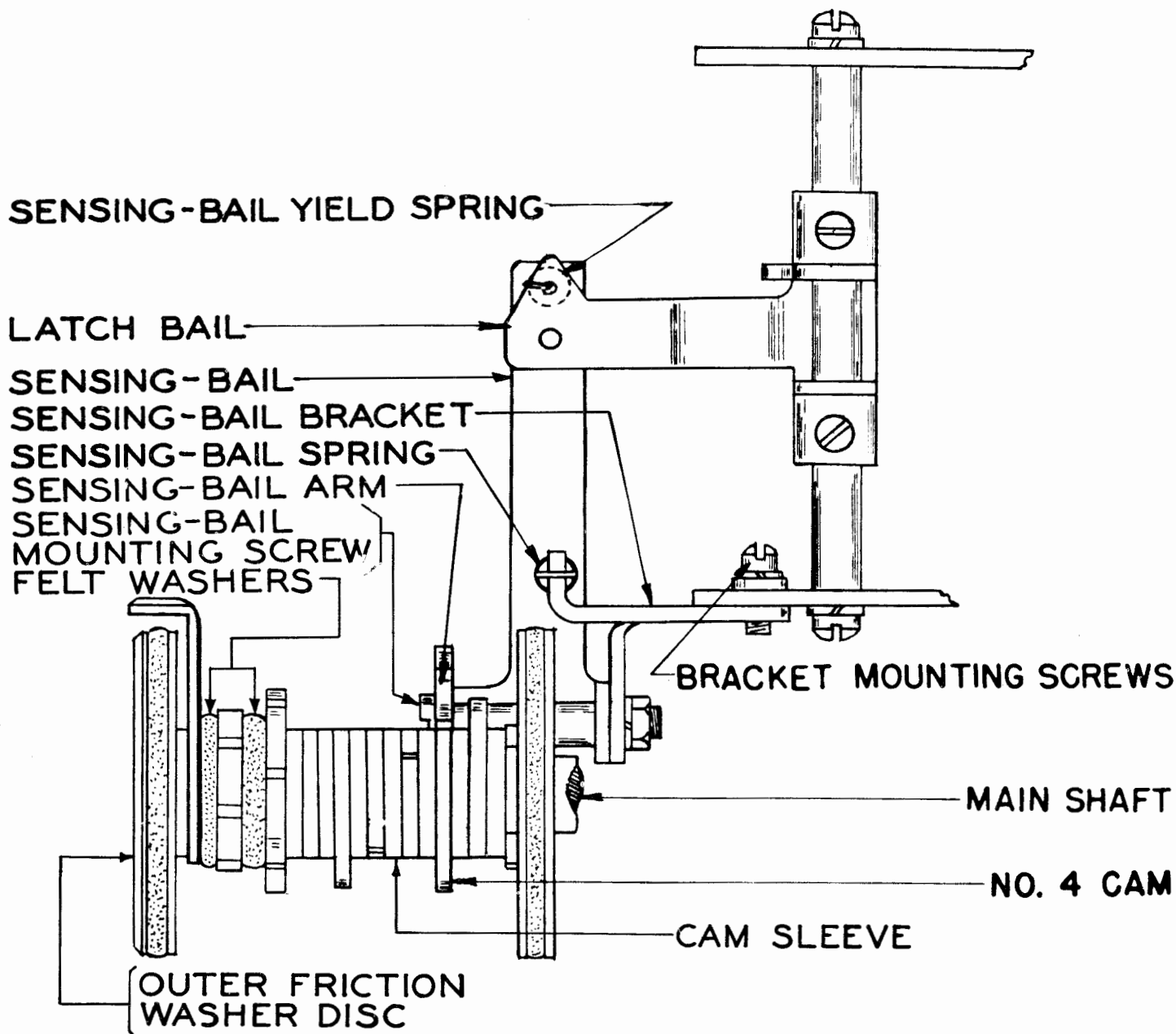

Figure 6

- (d) Remove the selector camsleeve by slipping it off the shaft. (See Figure 6.)
- (e) Rest the unit on its top, unhook the detent-lever spring and disengage the detent lever from the detent cam.
- (f) Apply a wrench to the nut (TP72517) located behind the selector-clutch spring while holding the main shaft with

another wrench at the flattened portion in the middle of the shaft (if provided) and loosen the nut.

(g) Remove the thumb screw and leather washer from the gear end of the main shaft and remove the gear-hub mounting screw.

(h) Remove the four mounting screws from the square end plate that

holds the main shaft right-hand ball-bearing. Note which position the screws come from so that they may be returned to their original positions. Two of the screws are locating shoulder screws.

(i) While holding the nut, previously loosened, on the selector end of the main shaft, back off the main shaft until the nut, spring, inner felt washer, and discs can be removed from the main shaft. Discard the nut.

(j) Assemble the capstan nut on its associated keyed nut (this is a tight fit) and proceed to reassemble the spring, washer, and discs in the reverse order on the main shaft.

(k) Remount the square plate, gear-hub mounting-screw, leather washer and thumb screw, detent lever and spring, selector camsleeve, outer friction washer and discs, range finder, and sensing-bail.

2.04 Selector Cams shall line up with their associated levers.

2.05 Armature Lever (holding magnet) shall have a barely perceptible amount of end-play (not more than 0.002 inch) when the armature lever and selector-arm springs are unhooked. See Figure 7 for identification of parts. (See Figure 8.)

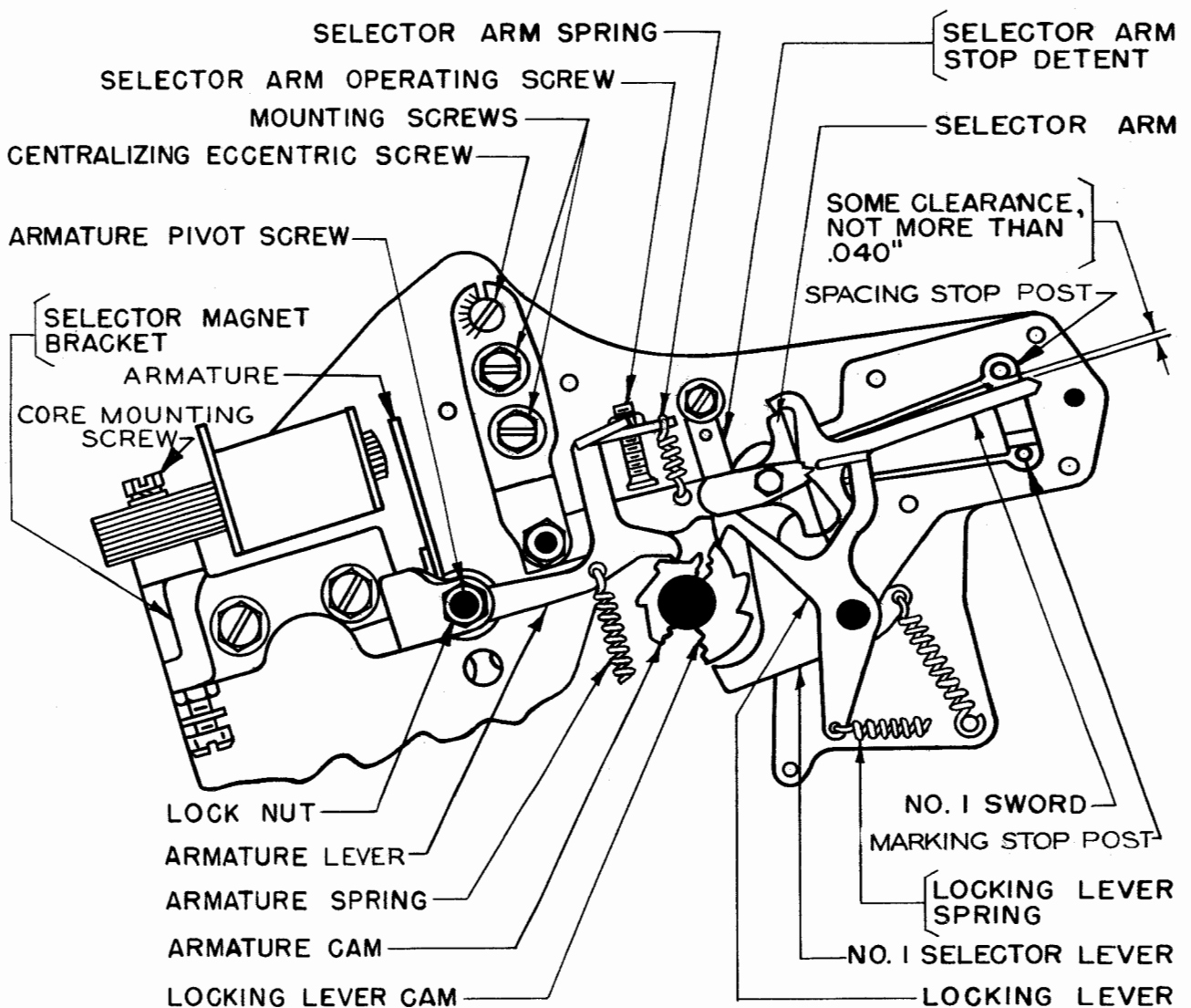

Figure 7

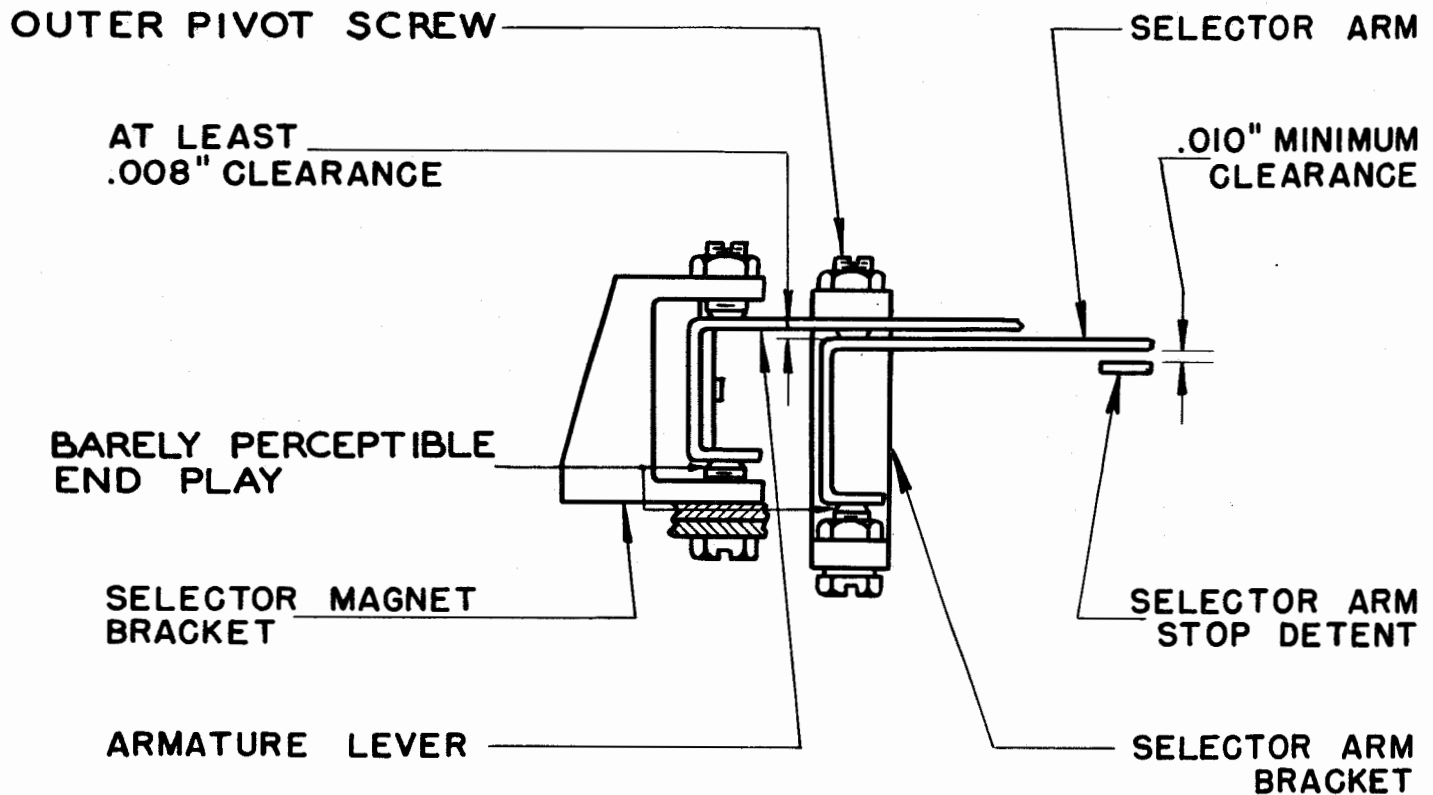

Figure 8

To Adjust: Position the outer armature pivot-screw, noting that 1/4 turn of the screw is equivalent to approximately 0.006 inch adjustment.

2.06 Armature (holding magnet) when in its operated position should touch both magnet cores at approximately the centers of their pole faces; and the cores should be centrally located with respect to the armature, as gauged by eye when holding a light background behind the magnet and armature assembly.

**CAUTION:** MAKE SURE ARMATURE AND POLE FACES ARE FREE OF OIL AND DIRT.

Note: This adjustment can be checked on 0.020 amp current without disassembling parts (other than unhooking the armature spring and the selector-arm spring) by measuring the magnet pull with the switch in the S position (coils in series shunted by 5000-ohm resistance). Under these conditions and with the armature adjusted correctly, it should require a pull of at least 3-1/2 pounds applied at a right angle to the armature edge, midway between the cores, to pull the armature away from the cores.

To Adjust: Remove the selector-magnet bracket from typing unit, loosen the core mounting screws and position the magnet-core assembly while holding the assembly so the cores are vertical and the armature rests against the pole faces by its own weight.

2.07 Selector Arm (holding magnet) shall be free in its bearings with barely perceptible endplay (not more than 0.002 inch) and the locking lever shall overtravel the top and bottom edges of the locking wedge, with the armature-lever spring, the selector-arm spring, and the selector-arm stop-detent spring unhooked. There shall be a clearance of not less than 0.008 inch between the selector arm and the armature lever, and of not less than 0.010 inch between the selector arm and the selector-arm stop-detent when the play in the detent is taken up in a direction to make this clearance a minimum. (See Figure 8.)

To Adjust: Position the outer selector-arm pivot screw for endplay.



Note: If the minimum clearance requirements are not met, it will be necessary to remove the selector-magnet bracket and the selector-arm bracket and adjust both pivot screws of the selector arm.

2.08 Swords (holding magnet) should clear both stop posts by approximately equal amounts judged by eye, but not more than 0.040 inch measured as in Figure 7 after (1) removing springs from the locking lever, armature lever, and selector arm, (2) placing associated selector lever on the peak of its cam, (3) placing the sword arm against the selector arm, and (4) moving the selector arm slowly from its unoperated or operated position to a point where the selector arm just clears the sword arm.

Note: Use No. 1 sword in gauging and adjusting, then check remaining swords. Because of the possible variation in parts the above 0.040-inch requirement is not intended to apply to each individual sword, but rather to all swords considered together.

To Adjust: Loosen the selector-arm bracket until held friction tight. Equalize the clearance between the swords and stop posts by turning the centralizing eccentric screw.

Make sure that the selector-arm stop-detent does not interfere and that the eccentric indicating line is adjacent to the scale on bracket. Then move the bracket closer or further away from the swords by inserting the TP90783 wrench in one of the two holes provided and turning the wrench.

2.09 Locking Wedge (holding magnet) should clear the locking lever by minimum 0.005 inch, maximum 0.012 inch when the locking lever is resting on the long high part of its cam and the end of the wedge is held in line with the lever. (See Figure 2.)

To Adjust: Position the locking wedge.

2.10 Locking-lever Spring (holding magnet) should require minimum 4 ounces, maximum 5-1/2 ounces, as indicated in Figure 2, to start the lever moving away from the high part of its cam.

2.11 Locking Lever (holding magnet) should clear the sides of the locking wedge by equal amounts within 0.003 inch, as indicated in Figure 9, as gauged by eye when the selector arm is in its operated or unoperated position.

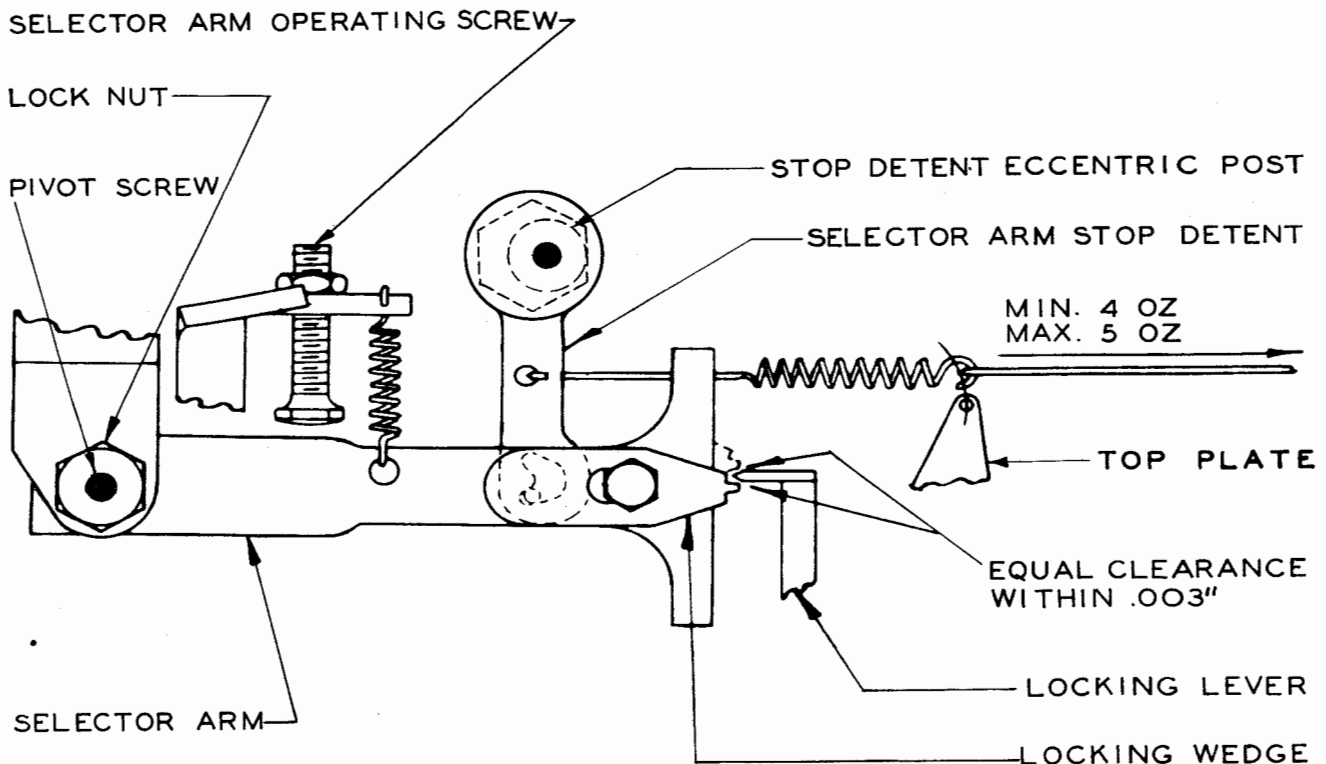

Figure 9

SECTION 572-006-700

Note: Make sure that the selector-arm operating-screw does not interfere with the selector arm.

To Adjust: Position the selector-arm stop-detent eccentric post.

2.12 Selector-arm Stop-detent Spring (holding magnet) should require a pull of minimum 4 ounces, maximum 5 ounces, as indicated in Figure 9, to stretch the spring to position length.

2.13 Armature Lever: The end of the armature lever (holding magnet) should clear the face of a cam tooth by minimum 0.058 inch, maximum 0.065 inch, as indicated in Figure 10, when the locking lever has just dropped off a long high part of its cam, the cam is held back against the locking lever, and the selector arm

is held in its operated position by the locking lever.

Note: When checking the above requirement, the armature lever should be held approximately 0.045 inch from the bottom of the notch of its cam. The wider the clearance, the more negative internal bias. Values between 0.058 inch and 0.062 inch are usually the most favorable, especially at 75 speed.

To Adjust: Loosen the screws holding the selector-magnet bracket and the selector-magnet-bracket adjusting arm until they are held friction tight, then reposition the selector-magnet bracket by inserting and turning the TP90783 wrench in the hole above the adjusting arm end. Tighten the screws.

SELECTOR MAGNET BRACKET  
ADJUSTING ARM

MOUNTING SCREWS

ARMATURE LEVER

MIN. .058"  
MAX. .065"

ARMATURE  
LEVER  
CAM

LOCKING LEVER

LOCKING LEVER CAM

SELECTOR MAGNET  
BRACKET

ADJUSTMENT HOLE

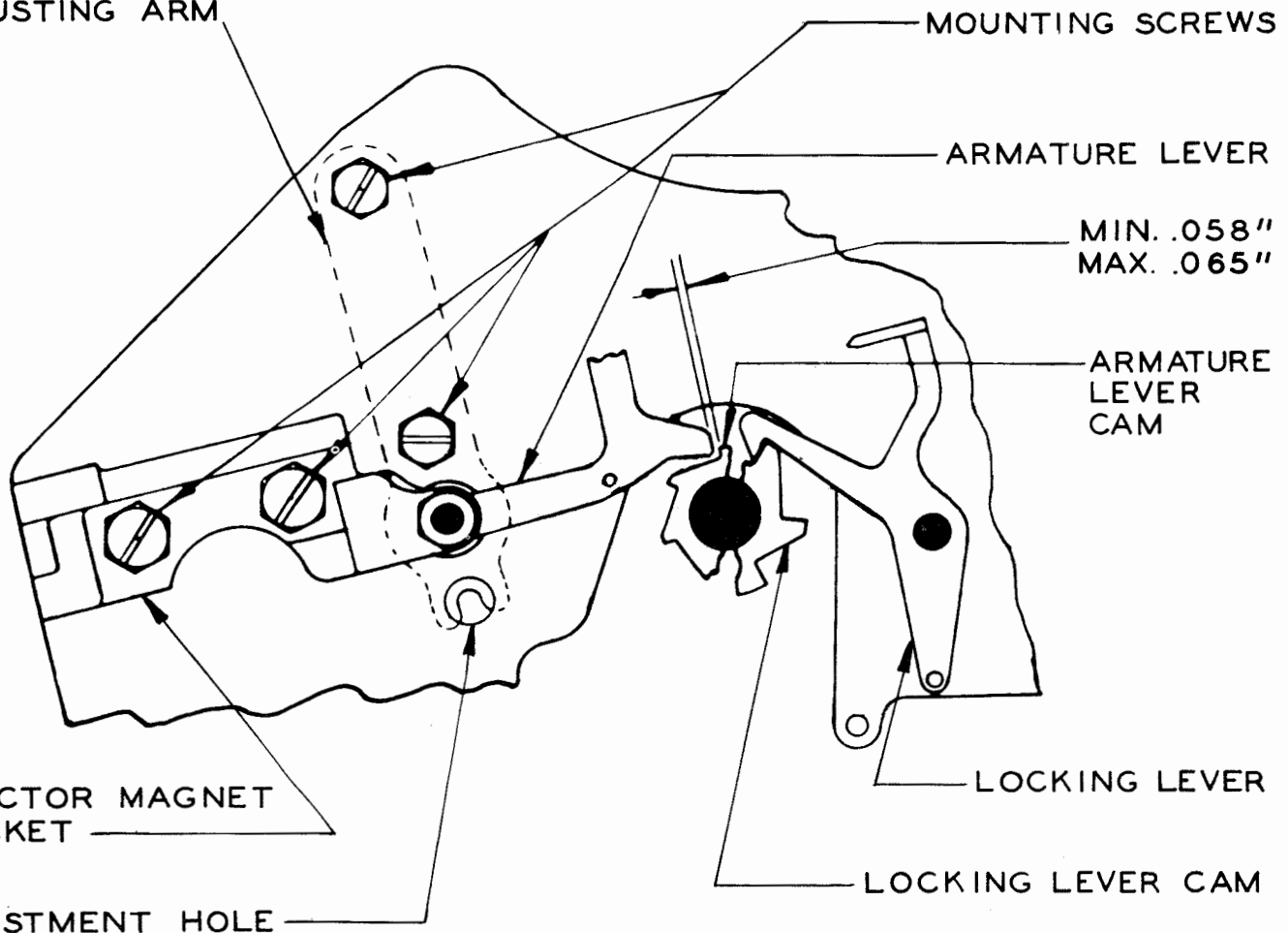

Figure 10

2.14 Armature-lever Spring: With the armature-lever spring unhooked, rotate the main shaft until the armature lever is on the high part of its cam. It shall require a pull as follows, to stretch the spring to its position length: (See Figure 11.)

(a) When a signal distorting set is available, the pull shall be some value between 13 ounces and 24 ounces such that the maximum orientation range is obtained for a given amount and type of distortion.

(b) Without a signal distorting test set, the pull shall be minimum 17 ounces, maximum 19 ounces, except when coils are connected in parallel without 1000-ohm shunt; then use a minimum 13-ounce, maximum 15-ounce pull.

To Adjust: For (a) and (b), loosen the spring arm mounting nut and position the arm. Tighten the nut.

2.15 Magnet Bracket (so-called jam adjustment for holding magnet):

Note: Jam refers to the fact that, in normal operation, the armature-lever assembly yields slightly when the lever rises to the peak of its cam and the armature is jammed against the magnet pole faces.

With the selector magnet energized, the clearance between the selector arm (in its marking position) and its operating screw should be: (1) when the armature lever is opposite a cam indent, minimum 0.003 inch, maximum 0.006 inch (see Figure 13) and (2) when the armature lever is on a cam peak, minimum 0.004 inch, maximum 0.006 inch greater than the particular value observed in (1) above. (See Figure 12.)

To Adjust: The adjustment required will depend on the nature of the departure from the requirements as indicated by the measurements above. Two possible cases are described separately below:

(a) If the amount of jam is correct [requirement (2) above], but the unjammed clearance [requirement (1) above], is not met, correct the trouble by adjusting the selector-arm operating screw.

(b) If requirement (2) is not met, or if neither requirement is met, or if a complete readjustment is desired, proceed as follows:

(1) De-energize the magnet.

(2) Loosen the selector-magnet-bracket mounting screws until they are friction tight.

(3) Loosen the locknut on the magnet-bracket adjusting screw and turn the screw in far enough so that, when the armature is held against the pole faces by hand, the armature lever clears the peaks of its cam. This insures starting the adjustment with a gap between the pole faces and the armature.

(4) Turn the main shaft until the armature lever is on a cam peak and then, holding the camsleeve from rotation, continue turning the shaft until the maximum throw of the lever on that cam peak is obtained. (Slight differences may be caused by eccentricity of the shaft.)

(5) With the selector arm in its marking position, adjust the selector-arm operating screw so that it clears the selector arm by 0.010-inch. Tighten the locknut on the selector-arm operating screw. Check that the 0.010-inch clearance is still maintained.

(6) Rotate the camsleeve until the armature lever is over a cam indent.

(7) With the armature held against the pole faces by the energized magnet, back off the magnet-bracket adjusting screw until the selector-arm operating screw clears the selector arm by 0.005 inch.

(8) Tighten the selector-magnet-bracket mounting screws and the locknut on the selector-magnet-bracket adjusting screw.

(9) Recheck both jam adjustment requirements given at the beginning of 2.15.

2.16 Selector-arm Spring (holding magnet) should require a pull of minimum 1-1/4 ounces, maximum 1-3/4 ounces, as indicated in Figure 13, to start the selector arm moving when the armature lever is on a high part of its cam and the selector-arm stop-detent spring is unhooked.

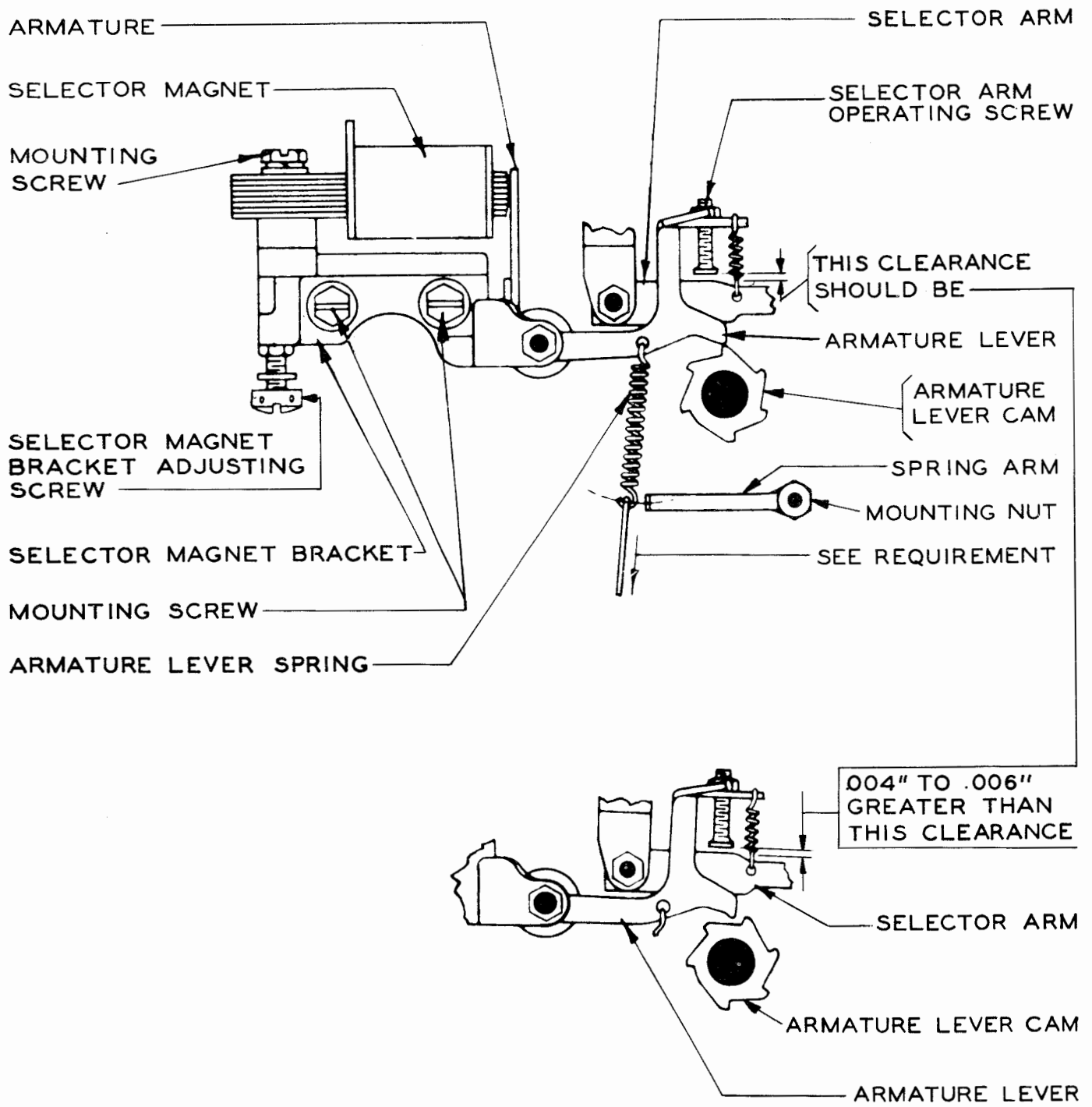

Figure 11

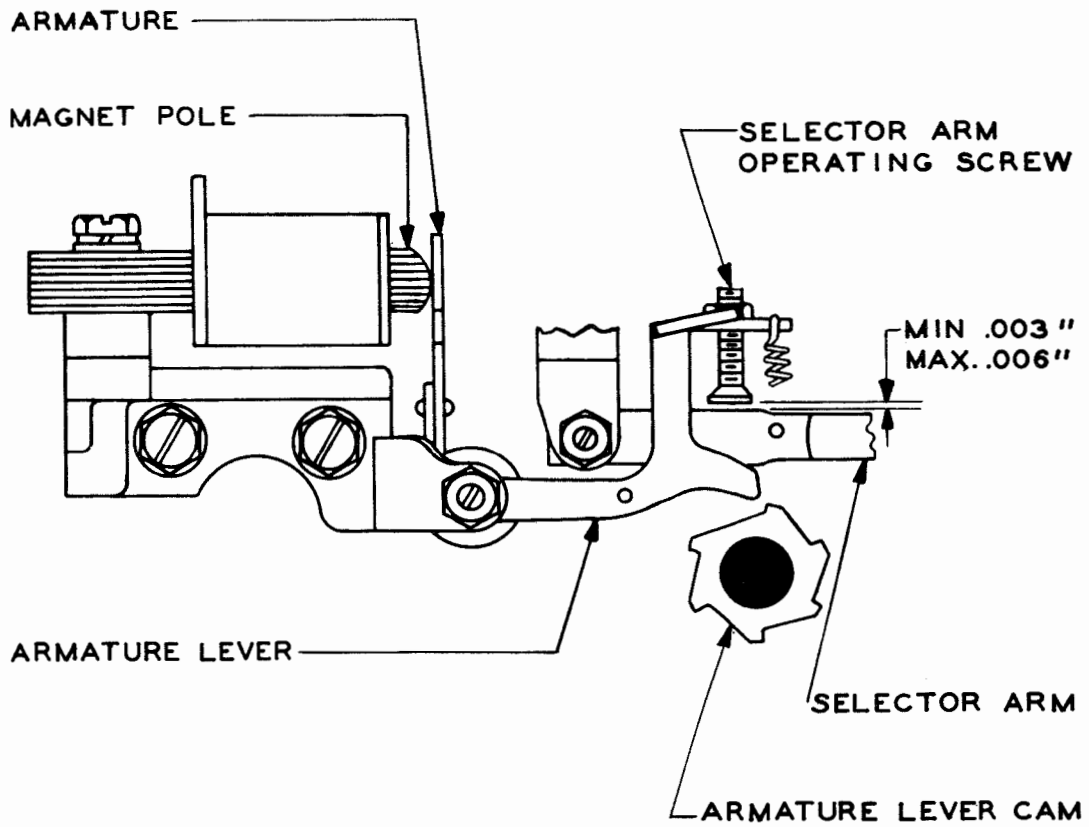

Figure 12

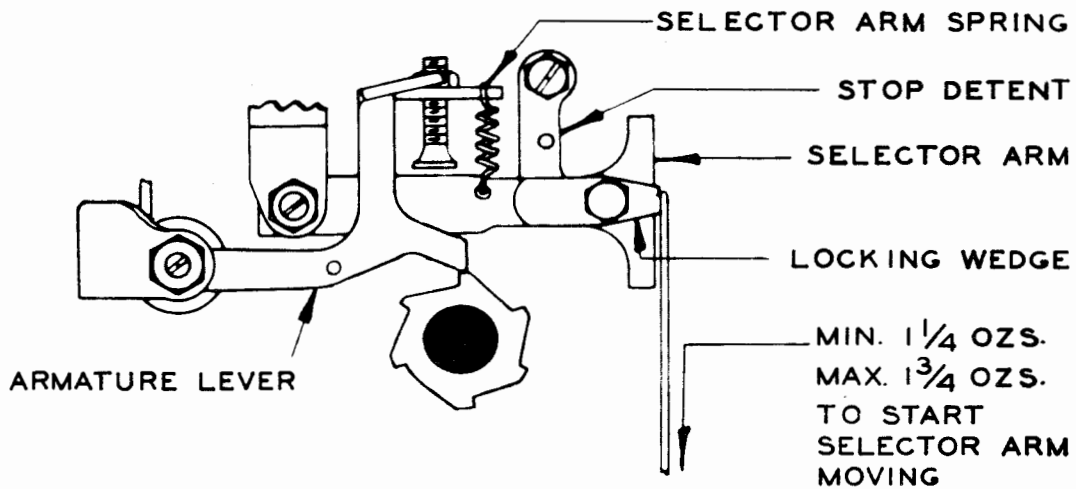

Figure 13

2.17 Armature (pulling magnet) should have a minimum amount of endplay, without bind in its bearings, gauged by eye and feel, and its locking wedge should clear the No. 1\* sword by not more than 0.008 inch as indicated in Figure 14 when the No. 1\* selector lever rests on peak of its cam, the No. 1\* sword front arm is held against outer separator plate without bending the separator plate and the armature endplay taken up to reduce the clearance to minimum.

To Adjust: Position the armature-bearing pivot screw, noting that 1/4 turn of the screw is equivalent to approximately 0.006 inch adjustment.

Note: In replacing the armature bracket make sure the armature spring clears the bracket and its mounting screw.

2.18 Swords (pulling magnet):

(a) The centerline of the No. 1 sword shall intersect the longitudinal axis of the armature pivot screw, as gauged by eye, when the

swords are held centrally located between the stop posts with TP72581 gauge pins (See Figure 15.)

To Adjust 1: Unhook the locking-lever spring; loosen the magnet and armature-bracket mounting screws and bracket-link screw (see Figure 16); back off the armature stop screw and nut; move the armature-bracket eccentric out of the way; take out the two motor stoplever-bracket mounting screws and lift out the bracket on units so equipped; rotate the camsleeve until the No. 1 selector lever rests on the peak of its cam; place the armature so that its extensions are between the sword arms and insert TP72581 gauge pins between the posts and swords as in Figure 15; place a TP73370 locating gauge over the end of the No. 1\* sword so that the legs of the gauge are against the ends of the sword arms, move the armature bracket to a position which will bring the end of the armature extension flush against the flat surface between the

\*See 1.04.

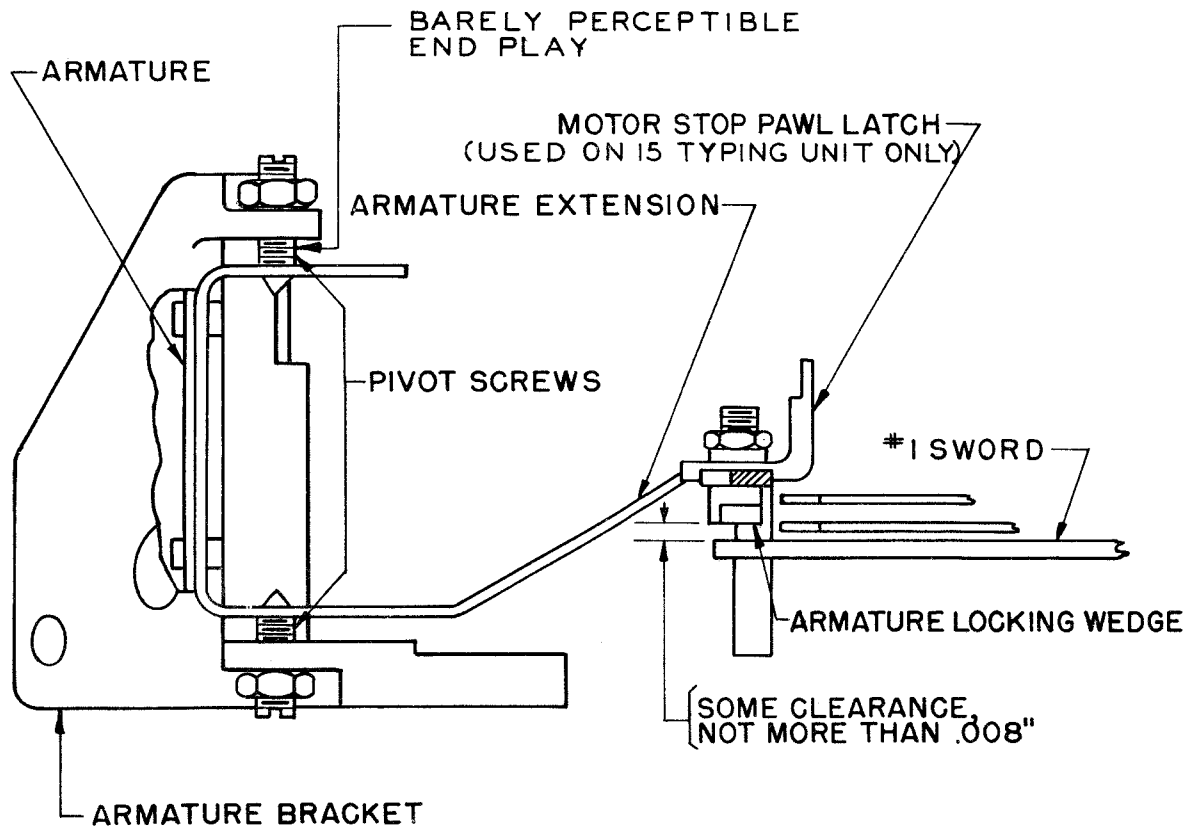

Figure 14

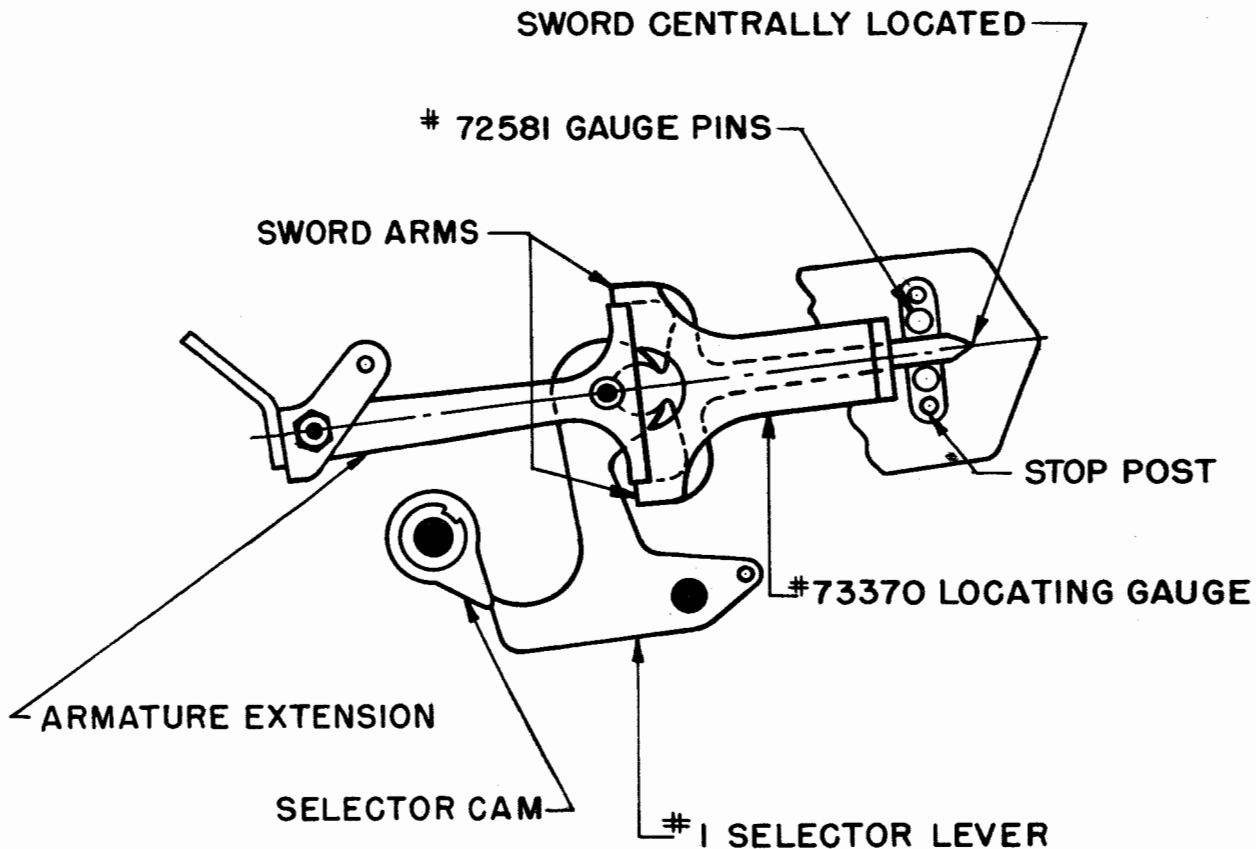

Figure 15

legs of the gauge; then holding the bracket in this position, tighten the link screw and armature-bracket mounting screws.

**To Adjust 2:** For 20-type machines equipped with the armature detent:

- (1) Unhook the armature-detent spring from the armature detent.
  - (2) Proceed as in (1) above.
  - (3) Rehook the armature-detent spring.
- (b) Rotate the main shaft until the No. 1\* selector lever is on the peak of its cam. With the armature in its unoperated position, move the spacing arm of the No. 1\* sword against the armature extension. Slowly move the armature from its unoperated position to a place where its extension just clears the sword arm. There should be some clearance,

not more than 0.040 inch, as indicated in Figure 16, between the sword arm and the stop post. Repeat the procedure with the marking arm against the armature extension and move the armature from its operated position.

**Note:** Use the No. 1\* sword as a guide in gauging and adjusting, then check the remaining swords.

**To Adjust:** Position the armature bracket backward to increase the clearance and forward to decrease the clearance. Tighten the mounting screws and then move the eccentric stop against the bracket and tighten its screw.

**Note:** The eccentric stop is provided so that the armature bracket can be removed and reassembled without changing its adjustment, provided it is held against the stop while the

\*See 1.04.

SOME CLEARANCE, NOT MORE THAN .040"

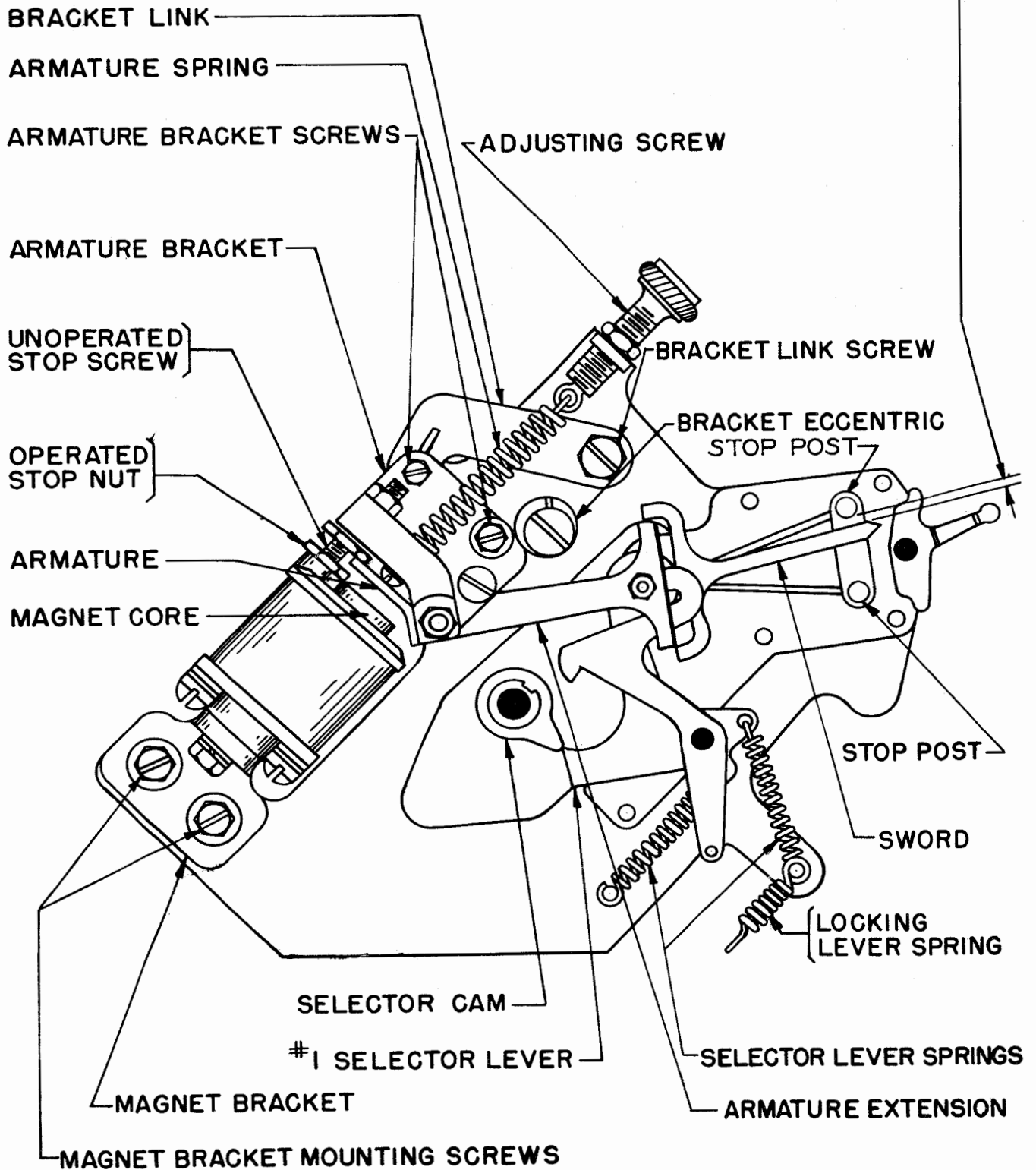

Figure 16



clamping screws are tightened and provided the link screw is not loosened. (See Figure 16.)

2.19 No. 1 Sword Arms\* (pulling magnet) should clear the associated arms of the armature extension by minimum 0.035 inch, maximum 0.037 inch (five-unit), minimum 0.040 inch, maximum 0.042 inch (six-unit), as indicated in Figure 17, when the end of the opposite sword arm is against its armature-extension arm and the No. 1 selector lever is on the high part of its cam.

Note: The upper limit for the five-unit apparatus may be increased up to 0.042 inch only if necessary to permit meeting the requirements for clearances given in 2.30

To Adjust the upper or left arm clearance (Note 1), position the armature stop screw with the armature unoperated; to adjust the lower or right arm clearance (Note 1), reposition the armature stop nut with the armature operated. If either clearance is changed, recheck clearance of the other arm. (See Figure 16.)

**CAUTION:** BE SURE THE STOP NUT IS TIGHT ON ITS SCREW. PINCH THE SPLIT HUB IF THE NUT IS LOOSE.

\*See 1. 04.

Note: The arms are designated upper and lower on apparatus which has the main shaft mounted horizontally; left and right on apparatus which has the main shaft mounted vertically.

2.20 The Armature Spring (pulling magnet) should have a tension of minimum 6 ounces, maximum 6-3/8 ounces when the armature is released and the spring is stretched to position length.

To Adjust: Position the selector-armature spring adjusting screw. (See Figure 16.)

2.21 Armature-locking Wedge (pulling magnet) should clear the locking lever by minimum 0.006 inch, maximum 0.012 inch when locking lever is resting on long high part of cam. (See Figure 18.)

To Adjust: Position locking wedge in its slot in the armature extension.

Note: When making this adjustment on typing units equipped with a mechanical motor-stop mechanism, set the motor stop-pawl latch so that the shoulder of the latch is against the front face of the armature extension. (See Figure 14.)

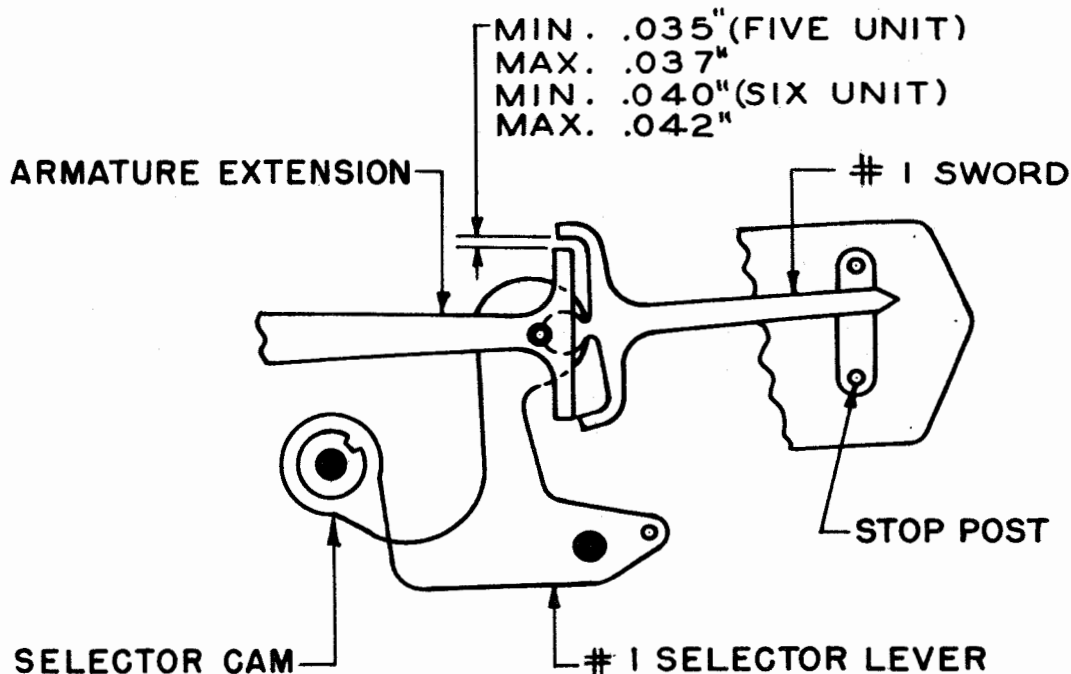

Figure 17

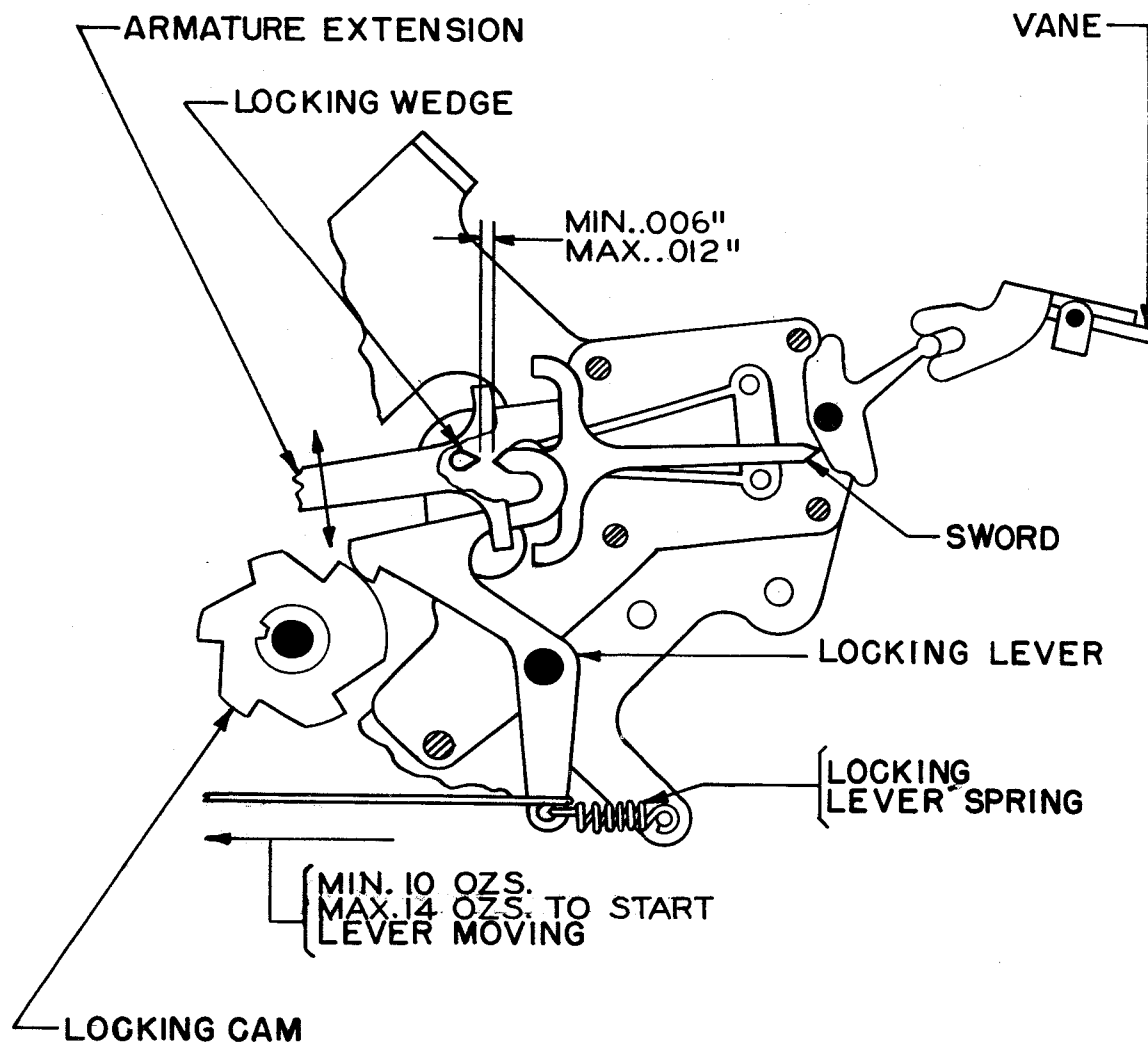

Figure 18

2.22 Armature-locking-lever Spring (pulling magnet) should require a pull of minimum 10 ounces, maximum 14 ounces, as indicated in Figure 18, to start the locking lever moving when the locking lever is on the long high part of its cam.

2.23 Magnet Bracket (pulling magnet): Magnet-core ends should be approximately parallel to the armature, as gauged by eye, and should have a clearance between the core ends and the armature, when the armature is held in the operated position, as follows (see Figure 16 for identification of parts): old-style armature with nonmagnetic antifreeze strip, minimum 0.002 inch, maximum 0.007 inch; new-style chromium-plated armature, minimum 0.003 inch, maximum 0.010 inch; and 20-type apparatus, some to 0.004.

Note: The 20-type apparatus uses exclusively the new-style armature and laminated core.

To Adjust: Reposition the magnet bracket, making sure that the mounting-screw washers are the heavy type, approximately 3/32 inch thick.

2.24 Armature-detent Mounting Bracket (pulling magnet) (for 20-type machines equipped with the armature detent): The armature detent should be central with respect to the detent pin on the selector-armature extension (when the armature extension is at its mid-position). This may be checked as follows (see Figure 19).

(1) With the armature-detent spring in place, unhook the armature spring from its adjusting screw.

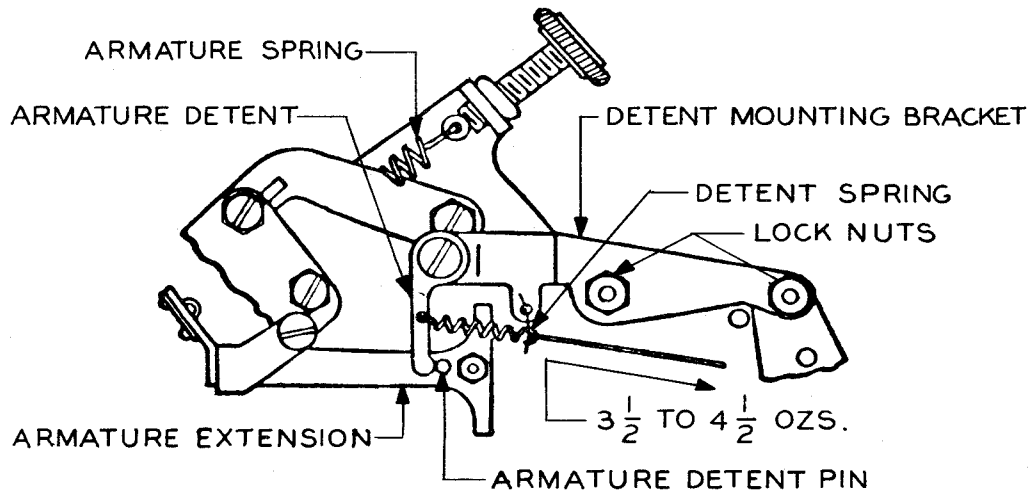

Figure 19

(2) Lubricate the detent.

(3) Check the pressure required to push the armature extension over the detent in going to both the marking and the spacing positions. An equal pressure should be required in both directions. (This pressure may be measured with a gauge pressed against the armature tripoff eccentric screw in the direction of its travel.)

To Adjust: Loosen the armature-detent mounting-bracket mounting screws and reposition the bracket.

Recheck: The requirement after tightening the screws.

Rehook: The armature spring.

2.25 Armature-detent Spring (pulling magnet) (for 20-type machines equipped with the armature detent): With the pull end of the scale hooked in the spring eye, it should require minimum 3-1/2 ounces, maximum 4-1/2 ounces, as indicated in Figure 19, to pull the detent spring to position length.

Note: Range-finder mechanism adjustments 2.26 through 2.30.

**CAUTION:** CHECK FOR SLUGGISH ACTION AND BINDS. IF NECESSARY, DISASSEMBLE AND CLEAN.

2.26 The Triplatch Spring: Compression, measured when the range finder is horizontal should be: (See Figure 22.)

#### SEQUENTIAL SELECTORS (SOTUS) AND 100-SPEED TELETYPEWRITER APPARATUS

	<u>Old-Style Triplatch</u>	
	<u>Min</u> (OZ)	<u>Max</u> (OZ)
Sequential Selectors (SOTUS)	1	1-1/2
100-Speed Teletypewriter Apparatus	3	3-1/2
<u>New-Style Triplatch*</u>		
Sequential Selectors (SOTUS)	2-3/4	3-1/4
100-Speed Teletypewriter Apparatus	2-3/4	3-1/4
60- or 75-Speed Teletypewriter Apparatus	1	1-1/2

2.27 Stoplever should have some clearance, not more than 0.006 inch, as indicated in Figure 22, from the latching surface of the triplatch when the stoplever is resting against the stoplever eccentric screw.

To Adjust: Position the stoplever eccentric screw.

\*New-style triplatches TP6830, TP90088, TP110871 are identified by a 60 degree bevel at the end of the engaging surface with the stop pawl.

2.28 Stoplever Spring: It should require a pull of minimum  $3/4$  ounces, maximum  $1-1/4$  ounces, as indicated in Figure 20, to start the stoplever moving.

Note: Check 2.27 before measuring this tension.

Note: Reassemble range finder assembly on unit taking care not to jam the triplatch plunger on tripoff screw (eccentric screw on units having pulling magnets). Tighten the mounting screws while holding the plate tight against the screws and toward the magnet-armature tripoff screw.

2.29 Range-finder Positioning Link: Stoplever (For machines having the TP119629 positioning link, not shown in Figure 22) should overtravel the latching surface of the triplatch at least half but not more than the width of the stoplever, with the

selector-magnet armature in the spacing position and the selector camsleeve rotated until the stoparm moves the stoplever to its maximum travel beyond the step of the triplatch. This should be checked with the range indicator set in turn at 0, 60, and 120 on the range scale. In checking at 120 it probably will be necessary to operate the triplatch manually in order to release the camsleeve assembly. See Figure 22 for identification of parts.

To Adjust: Loosen the range-scale-assembly mounting screws and the positioning-link mounting screw just enough to make them friction tight. Position the range-scale assembly and positioning link so that the overtravel of the stoplever is within the specified limits. Tighten the mounting screws and the positioning-link screw.

2.30 Armature Tripoff Screw (eccentric screw)\*  
There should be some clearance, not more

\*The parts in parentheses pertain to pulling-magnet selectors.

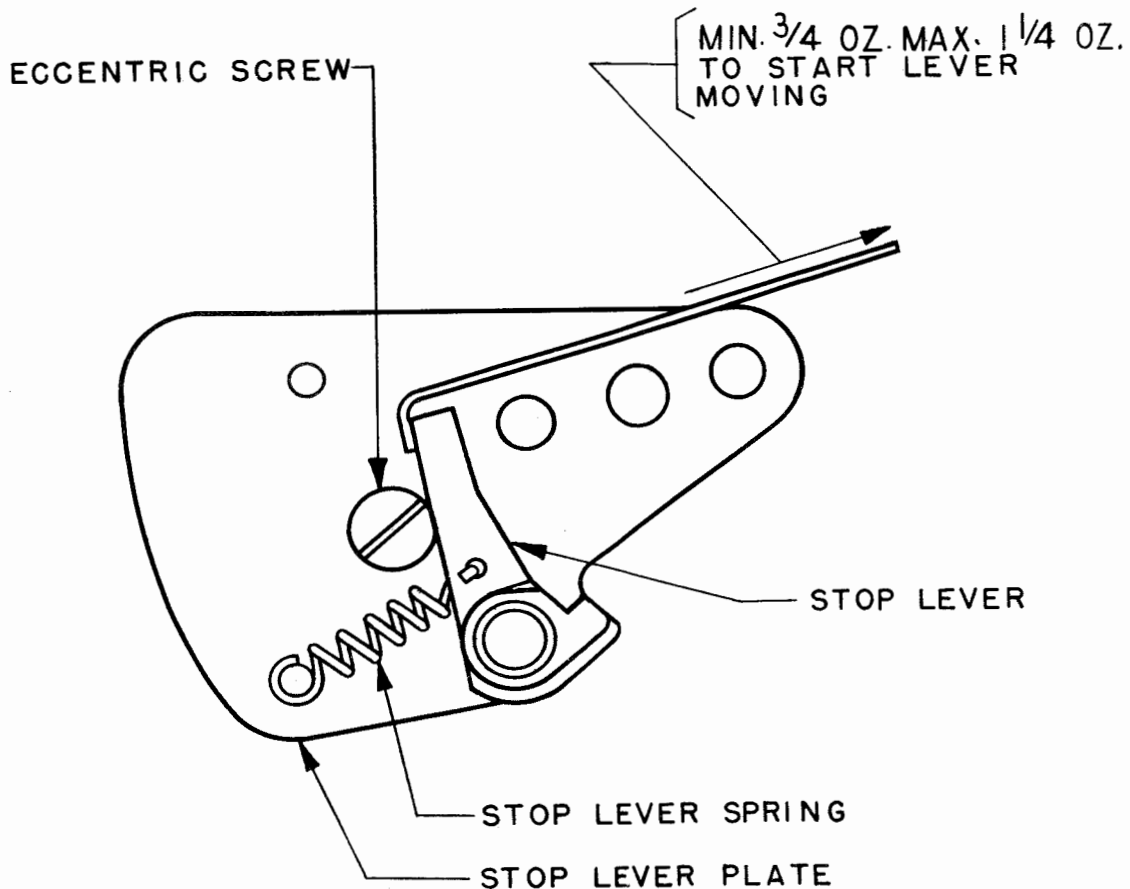
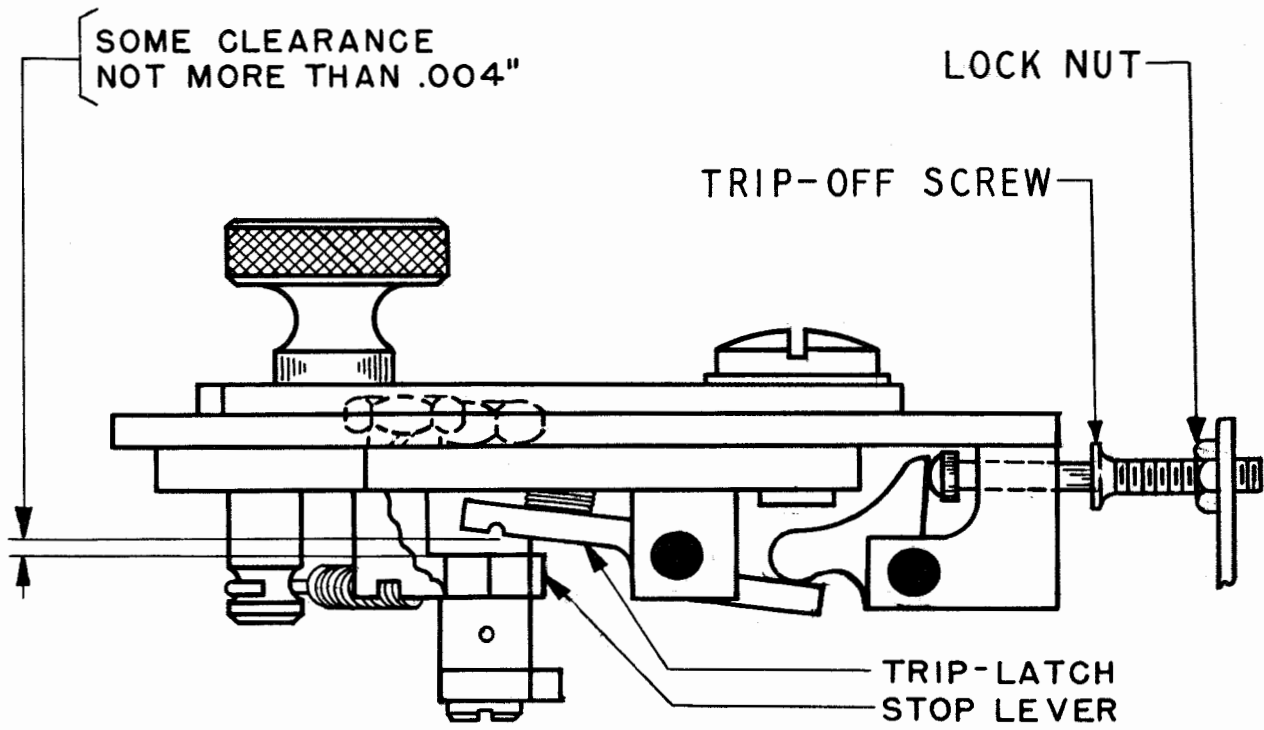
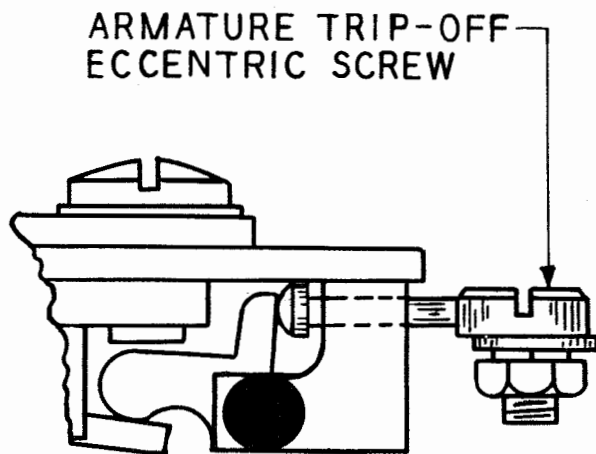

Figure 20



A



B

Figure 21

than 0.004 inch, as indicated in Figure 21, between the stoplever and the triplatch when the armature is in the unoperated position and the selector camsleeve is rotated until the stopping edge of the stoplever is directly below the latching surface of the triplatch. While checking the above clearance, take up the play in the stoplever by applying an axial thrust with a screwdriver in the direction of the triplatch, adjacent to the spring hole, and as close to the bearing as possible. This clearance should be held to a minimum to favor the endplay of the triplatch plunger. In addition, the triplatch plunger should have at least 0.002 inch endplay when the armature is held in the attracted position and when

the stoplever is resting against its eccentric stop post. (See Figures 21 and 22.)

**To Adjust:** Loosen the tripoff screw (trip-off eccentric screw) locknut and position the screw (eccentric) to meet the first requirement. The latter requirement serves as a check on the tripoff screw (tripoff eccentric) adjustment and also on the adjustment of the selector-magnet bracket (armature stops). (See Figures 21A, B.)

**Note:** If the throw of the eccentric screw of the pulling magnet selector is not sufficient to provide the required clearance, check 2.19.

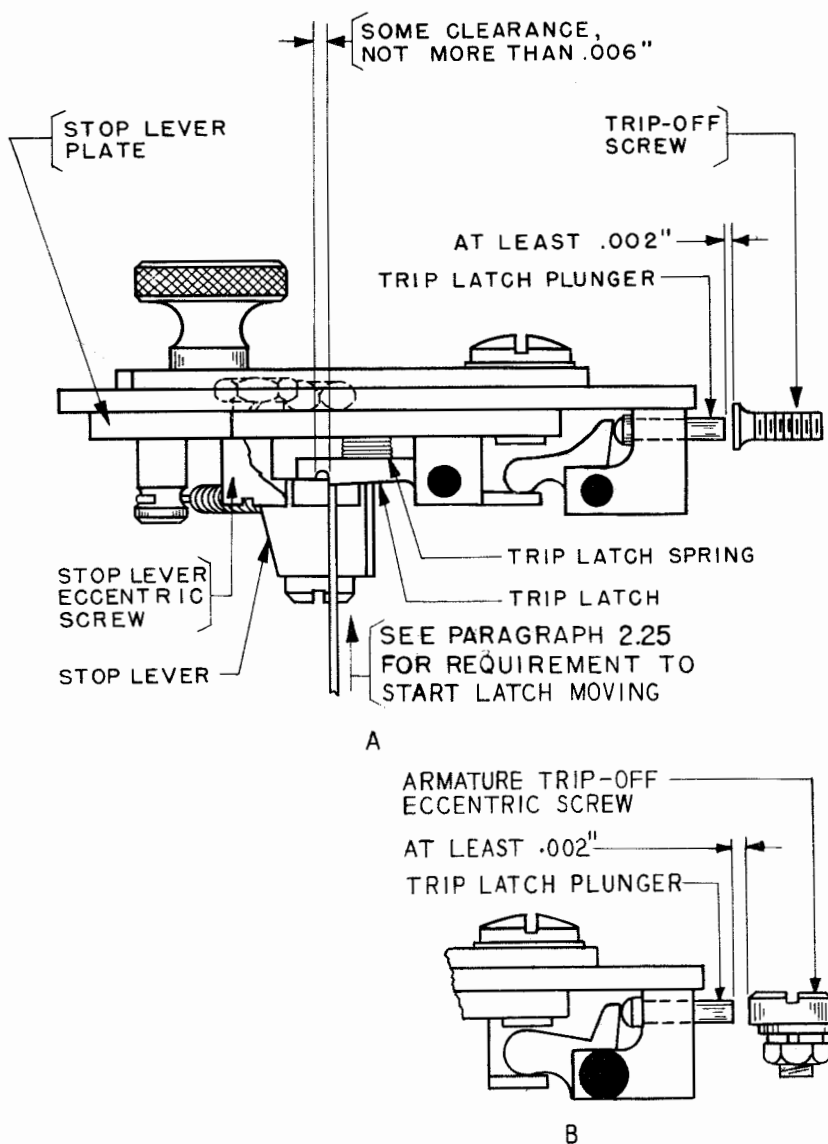

Figure 22