

DESCRIPTION OF AND INSTRUCTIONS FOR ASSEMBLING  
TELETYPE MODEL 19 PAGE PRINTER SET  
ADAPTED FOR SHIPBOARD USE

DESCRIPTION

The Teletype Model 19 set for shipboard use provides for the transmission and reception of typewritten messages over a telegraph circuit at a speed of 368 operations per minute (approximately 61 words per minute). Facilities are provided either for direct keyboard or tape transmission. All units mounted on the table, including the covers, are securely clamped in place. Resilient mounts are provided between the table and the bases of the printer and transmitter distributor to reduce vibration and severity of shocks which might be transmitted from the table to the associated units. The table legs are provided with angle iron rails to permit bolting to the deck.

COMPONENT UNITS

The Model 19 set consists of:

- (1) A typing unit which includes selecting and printing mechanisms for translating electrical code impulses into typewritten copy, and mechanisms which perform such functions as spacing, line feeding and carriage return.
- (2) A perforator transmitter unit arranged to operate in conjunction with associated units, as follows:
  - (a) Transmit direct keyboard and print a page copy.
  - (b) Transmit direct keyboard, print a page copy and simultaneously perforate a tape.
  - (c) Perforate a tape only.
- (3) A motor unit, 110/115 volt 60 cycle, series governed, for supplying the motive force for operation of the typing unit and for direct keyboard transmission.
- (4) A base unit for supporting the typing unit, motor unit, perforator transmitter unit and line relay, and for providing terminal connections for the various circuits. A motor control relay is also mounted on the base.
- (5) A set of gears, consisting of a pinion for the motor unit and a bakelite main shaft drive gear for the typing unit.
- (6) A line relay for relaying impulses from the signal line to the selector magnet of the typing unit.
- (7) A sheet metal cover (lined with sound absorbing material) for enclosing the printer and perforator transmitter mechanisms. This cover is fitted with a copy holder.

- (8) A transmitter distributor (with cover) for transmitting the code perforated in the tape.
- (9) A metal table for supporting the complete printer set and transmitter distributor. The legs of the table are provided with angle iron rails to permit bolting to the deck.
- (10) A speed indicator (tuning fork) for setting speed.

#### LINE CONNECTIONS

The printer set is normally wired for use on signal lines carrying .060 ampere D.C. line current, but may be operated on .020 ampere signal systems provided a wiring change indicated on wiring diagram is made. The transmitting and receiving lines are brought to separate jacks and terminal blocks on the table to facilitate connections with either neutral or polariential lines. A pair of local test jacks, complete with adjustable resistor, are also included in the electrical services of the table for convenience in operating the printer and transmitter distributor on local test. Connections between printer and table jacks are accomplished by means of a transmitting line cord with black shell plug and a receiving line cord with red shell plug.

#### MOTOR CONTROL

When the set is to be used in ordinary communication service, the typing unit is provided with the "upper case H" motor control feature which may be used to start and stop the motors of all machines (so equipped) on the circuit. To start and stop the motors, the "break" key and the "figures H" are operated respectively.

Printers arranged for weather report service use the "upper case" (or "figures") position of the printing type for the ten digits and necessary weather symbols, precluding the application of the "figures H" motor stop feature. For this type of service (if remote control of the motors is required) a separate line may be connected to the control relay on the printer base.

#### RADIO FILTERS

Filters are provided for all contacts where radio frequency induction might cause interference with radio receivers.

#### INSTRUCTIONS FOR ASSEMBLING

##### SECURING TABLE TO DECK

Locate the table so that the type bar carriage moves fore and aft, and bolt it to the deck by means of 1/2" bolts through the holes in the rails attached to the table legs.

##### INSTALLING PRINTER BASE AND PARTS FOR SECURING PRINTER COVER

With the vertical sections of the 104057 brackets toward the center of the table, mount these brackets in the holes provided in the left and right pad retaining channels on top of the table, using the 78301 screws, 2669 lock washers and 104059 spacer blocks furnished. The spacer blocks should be placed in the pad retaining channel at the bracket mounting screw holes.

With one 73175 lock washer on the short threaded end of each of the four 102809 studs, assemble the studs in the unmarked tapped holes in the bottom plate of the base unit (see Figure 1). Do not use the four holes marked "X".

Add three 83814 spacer washers on each of the studs just assembled and place the base unit on the table so that the studs enter the holes in the resilient mountings. Secure the base unit to the resilient mountings using the 103377 washers, 2920 lock washers and 85595 nuts.

#### MOUNTING THE MOTOR UNIT AND TYPING UNIT ON THE BASE UNIT

##### MOTOR UNIT

Mount the pinion on the motor shaft by means of the screw and lock washer already in the shaft.

Mount the motor unit on the rear right-hand corner of the base by means of three hexagonal head screws (in place on the base). Remove these three motor unit mounting screws and position the motor unit against the spring contacts. Holding the motor in this position, start the three mounting screws. Tighten the two forward screws and then back them off one-quarter turn. Do not tighten the rear mounting screw until the typing unit is in place.

##### TYPING UNIT

Remove the gear hub from the right end of the typing unit main shaft and assemble the printer main shaft drive gear to the hub. The screws for mounting the gear will be found in position in the hub. Replace the hub, with gear, on the main shaft of the typing unit. Two hexagonal studs are provided on the bottom of the typing unit for protecting its mechanisms from damage when the unit is being serviced on a bench, table, etc. When mounted on the base unit, these two studs enter clearance holes in the base.

To secure the typing unit to the base unit, three thumb screws are provided. Remove these screws from the base. The exact location of the typing unit on the base unit is determined by two dowel pins located on the two forward machined surfaces of the base unit. The right-hand dowel pin fits into a hole in the typing unit casting, while the left-hand dowel pin fits into a slot cut in the casting.

**CAUTION:** When setting the typing unit on the base unit, be very careful not to jam the bakelite main shaft gear against the motor pinion.

In lifting the typing unit, face the front of the unit. With the right hand grasp the flat projection on the typing unit right-hand casting. With the left hand grasp the extreme lower front corner of the left-hand casting. Lifting and moving should be done carefully so as not to put any part under undue strain which might throw it out of adjustment.

When setting the typing unit on the base unit, lower the left side first all the way, holding the right side so that when the left side is resting on the base unit, the main shaft gear is just ready to mesh with the motor pinion. Then with the left hand turn the motor flywheel and at the same time lower the right end of the typing unit, taking care that the motor pinion properly meshes with the main shaft gear.

Facing the front of the base, visually check the lateral alignment of the motor pinion and the main shaft gear, to determine if the center of the gear coincides with an imaginary vertical line through the center of the hole in the motor pinion. If these lines do not coincide, remove the typing unit from the base and loosen the four motor mounting screws.

Replace the typing unit on the base unit, and shift the motor to obtain the foregoing condition as nearly as it is possible to determine by eye. Make certain that the edges of the motor base are parallel to the edges of the motor plate. Then remove the typing unit and tighten the four motor mounting screws.

Loosen the rear motor plate mounting screw and the lock nut on the motor plate adjusting screw. Replace the typing unit and tighten the three typing unit mounting thumb screws. By means of the adjusting screw, adjust the vertical position of the motor pinion until there is a barely perceptible amount of backlash between the motor pinion and the main shaft gear, at the point where there is the least amount of backlash in one complete revolution of the main shaft.

**IMPORTANT:** Apply a film of grease to the motor pinion.

#### PERFORATOR TRANSMITTER UNIT

**CAUTION:** When sliding the perforator transmitter unit into the base unit, be very careful not to jam its bakelite gear against the steel gear with which it meshes on the main shaft of the typing unit.

The perforator transmitter unit slides into the opening in the front of the base unit on two angle irons acting as rails. The two plates, fastened under the perforator transmitter unit on the right and left-hand sides, go under the rails. The perforator transmitter unit is held in place by means of two thumb screws.

Slide the perforator transmitter unit in place slowly and, at the same time, rotate the motor flywheel back and forth to facilitate meshing of the gears. When the perforator transmitter unit is in place (in its rearmost position) tighten the two thumb screws.

#### TRANSMITTER DISTRIBUTOR

Place the transmitter distributor on its mounting rails on the table and slide it rearward until its base plate clears the heads of the stop screws at the forward end of the rails. From underneath the table, insert the 110422 thumb screw fitted with 2846 washer and 2322 lockwasher, upward through the transmitter distributor mounting plate and thread it into the base plate of the transmitter distributor.

#### TABLE AND PRINTER CONNECTIONS AND WIRING

Connect power and signal line wiring to the printer table as shown on wiring diagram W.D. 2161. Run the printer and transmission line wires from the line terminals shown on wiring diagram W.D. 2161 to a ship connection block where communication circuit connections may be made. If a separate motor control line is to be used, run two additional wires directly from terminals 51 and 56 on the printer base to the ship connection block, passing them through the hole in the top shelf of the table at the right-hand side of the base.

#### MOUNTING THE LINE RELAY

Loosen the mounting screws of the relay clamp brackets on the rear left corner of the printer base and spread the brackets sufficiently to permit the relay to be inserted. With the relay in position on the base, slide the clamp brackets as close as possible to the relay and tighten securely.

#### RIBBON AND PAPER

Install a ribbon on the printer as shown on Figure 2.

Place a paper roll on the paper spindle and feed it around the platen as shown on Figure 3.

#### PRINTER OPERATION

Insert the four cords of the base unit through the hole in the table top and plug the power cords into the corresponding table receptacles. Plug the two line cords into the test jacks as indicated.

Start the motor. Carefully readjust the vertical position of the motor pinion, by means of the motor unit adjusting screw, until the gear noise is reduced to a minimum.

**CAUTION:** Care should be exercised in adjusting the vertical position of the motor pinion while the motor is running, in order to avoid damaging the main shaft gear or reducing the speed of the motor due to binding of the gear and pinion.

Tighten the three motor plate mounting screws and the adjusting screw lock nut. Recheck the backlash between the motor pinion and the main shaft gear.

With the polar-neutral key on the keyboard in the neutral position (pulled outward) and the send-receive lever on the left side of the base in the send position (upward), the printer should be ready for test operation. When the system is ready for line operation, the line cords should be withdrawn from the local test jacks and plugged into the table line jacks on the left as indicated, and the polar-neutral key should be positioned for the type of operation intended. (See wiring diagram W.D. 2143).

#### ASSEMBLING AND MOUNTING THE PRINTER COVER

Mount the copyholder (packed for shipping in separate carton) on the sloping portion of the cover, below the glass window, by means of the four screws in the copyholder, with the wooden spacing strip between the copyholder and the cover.

Place the printer cover over the printer and secure it to the brackets on the table by means of thumb screws in either side of the cover.

For dimensions of complete Model 19 printer set, see Figure 4.

Attached to this specification are Figures 1 to 4, inclusive.

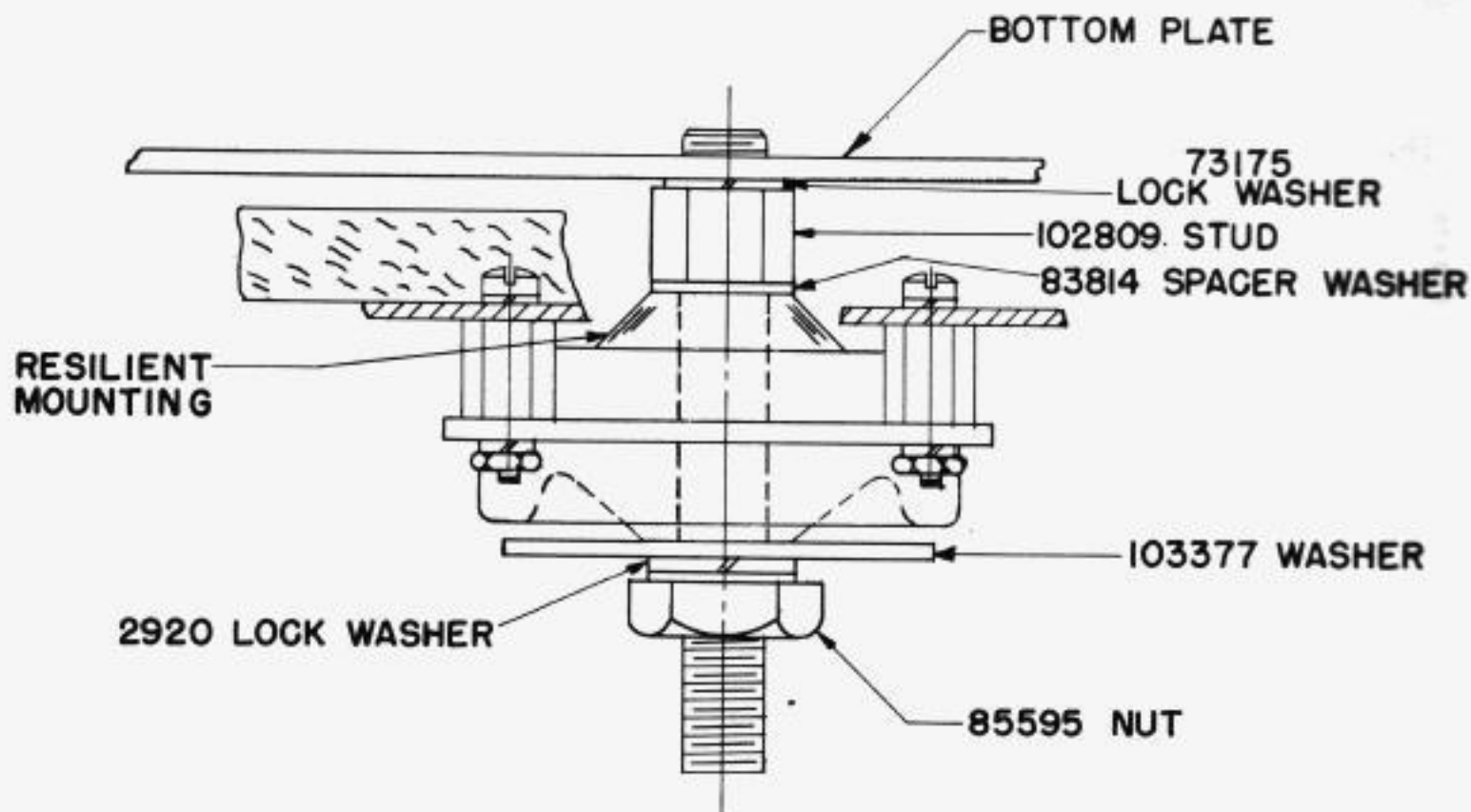

FIGURE 1

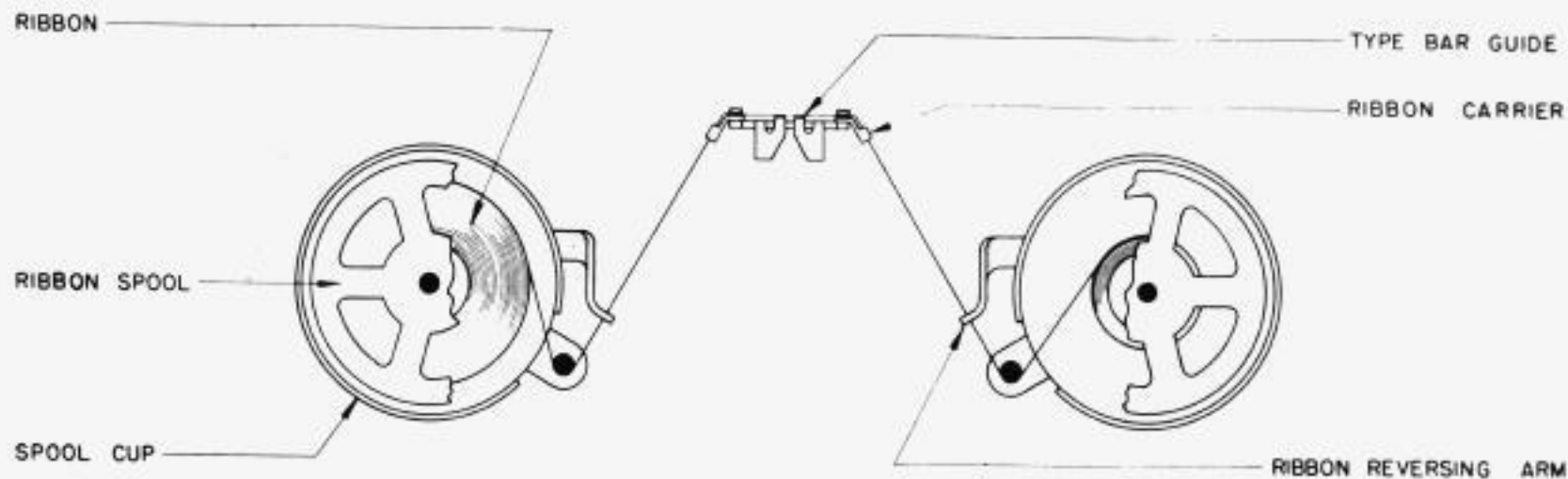

FIGURE 2

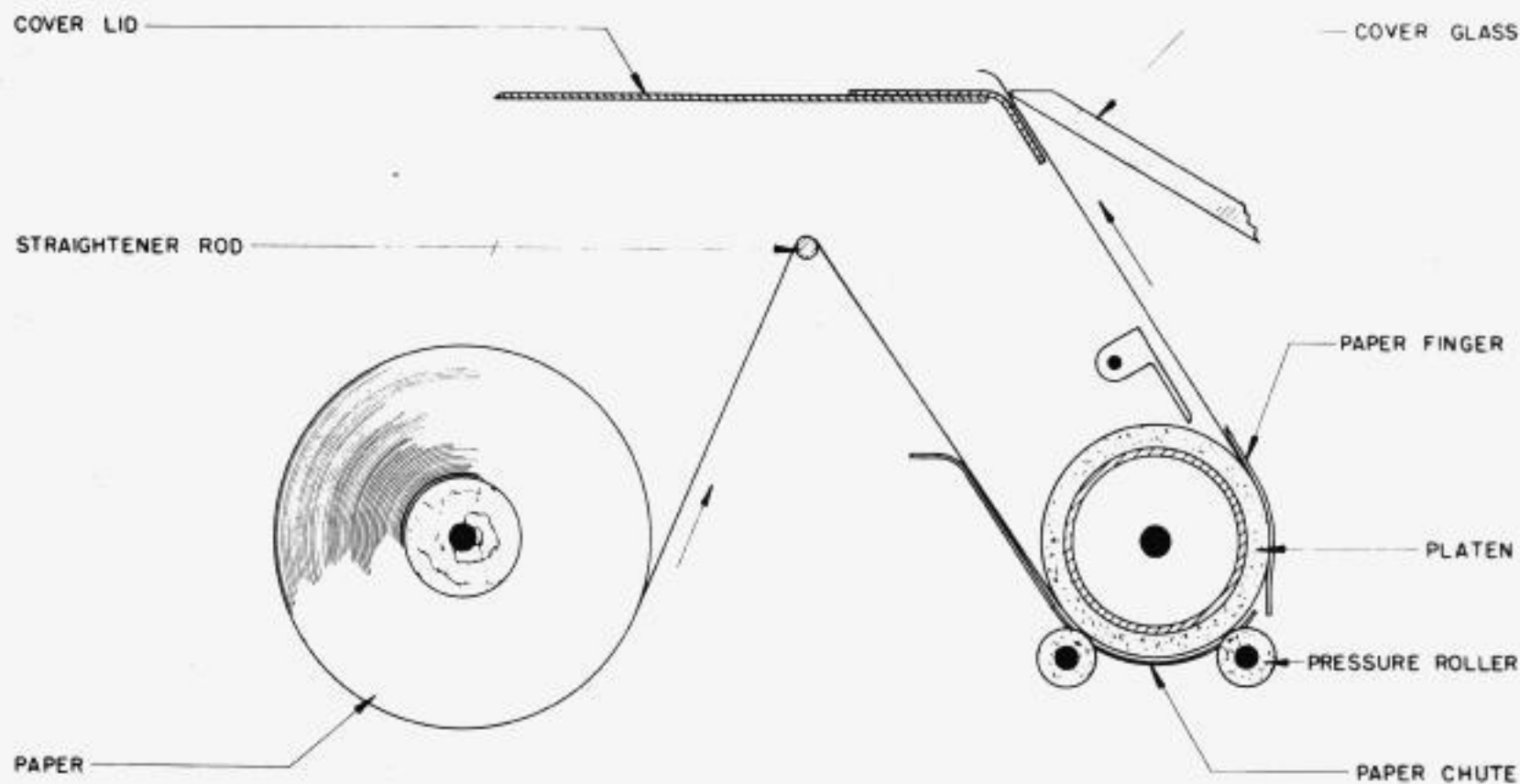

FIGURE 3

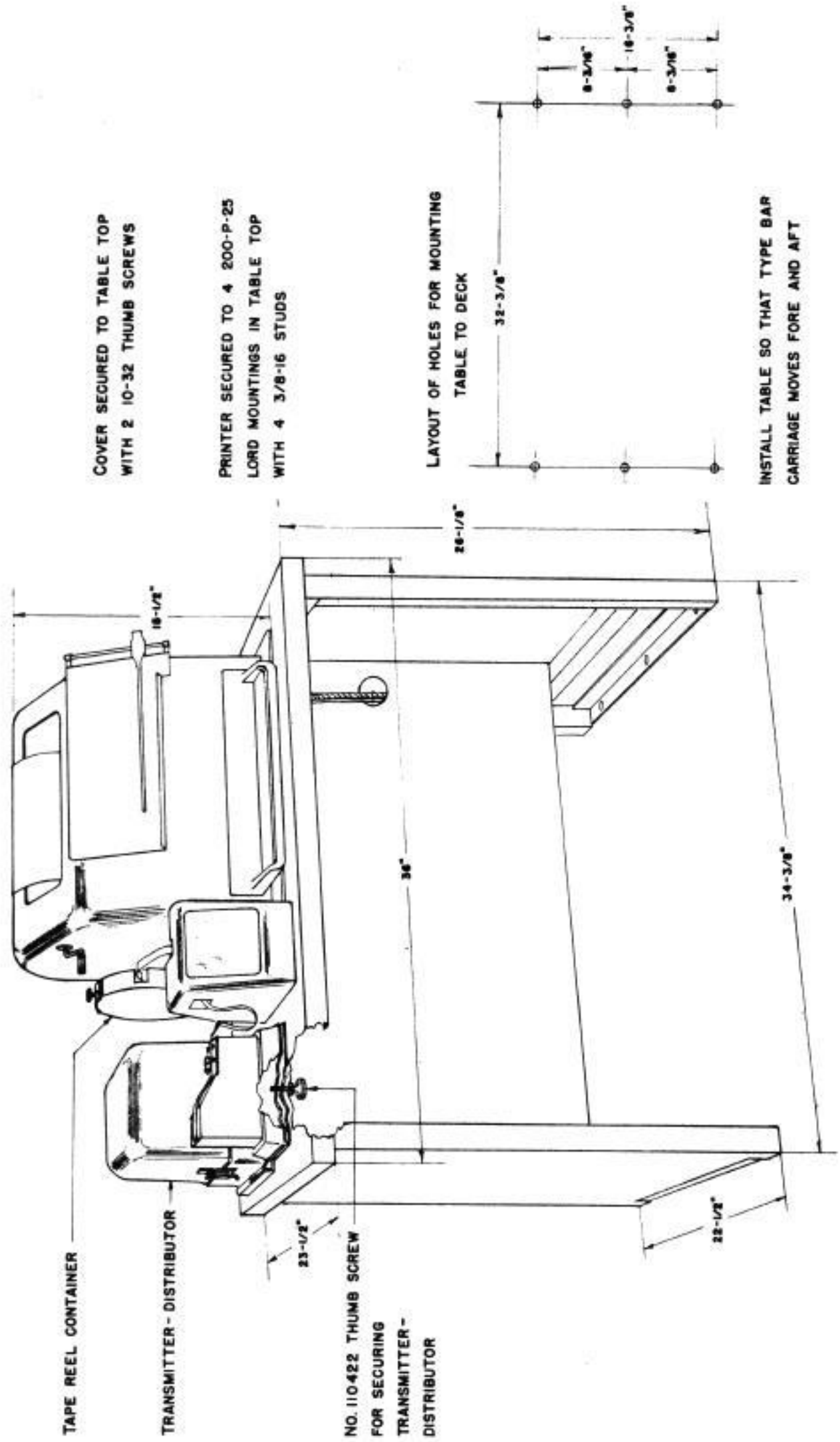

FIGURE 4