

32 AND 33 TAPE PUNCH

LUBRICATION

CONTENTS	PAGE
1. GENERAL	1
2. BASIC UNIT	2
Backspace lever	5
Codebar levers	4
Control mechanism	7
Detent lever	5
Drive link	8
Drive link mechanism	9
Drive link mechanism area	8
Feed mechanism	3
Feed pawl	5
Pawls and levers	4
Punch block assembly	7
Sensing levers	3
Stripper bail	4
Tape guide assembly	6
Tape guide roller	6
Tape punch	2

1.04 Lubricate the tape punch before placing it into service or prior to storage. After a short period of service, relubricate it to make sure no areas have been missed. Thereafter, lubricate the tape punch at regular intervals as indicated below:

<u>Operating Speed</u> (Words per Minute)	<u>Lubrication</u> <u>Interval</u>
60 or 66	1000 hr* or 1 yr**
100	500 hr* or 6 mo**

*Station Set operating hours.
**Whichever comes first.

1.05 The textual instructions that accompany the line drawings consist of abbreviated directions, specific lubrication points, and parts affected. The meanings of the abbreviated directions (symbols) are given below:

1. GENERAL

1.01 This section is issued to provide instructions for lubricating the 32 and 33 tape punch and to present the lubricating instructions as a separate section.

1.02 The general lubrication areas are illustrated by photographs. The specific points to receive lubricant are indicated on line drawings with appropriate textual instructions. Line drawings and textual instructions follow each photograph and are keyed to the photograph by paragraph numbers.

1.03 Thoroughly lubricate the tape punch, but avoid over lubrication that might permit the lubricant to drip or be thrown onto adjacent parts. Saturate all felt washers and oilers with oil. Use KS7470 Oil where oil is required and KS7471 Grease where grease is required.

<u>Symbol</u>	<u>Meaning</u>
D	Keep dry - no lubricant permitted
G	Apply thin coat of KS7471 Grease
GOL	Brush on well a mixture of 50% KS7471 Grease and 50% KS7470 Oil
OL	Oil liberally (3 or more drops)
OS	Oil sparingly (1 or 2 drops only)
OSAT	Saturate with oil (all washers and oilers)
OSD	Oil sparingly or leave dry**
OSL	Oil sparingly or liberally

**Applies to all areas not contacted by other parts.

1.06 References to "left," "right," "front," or "rear," etc consider the tape punch to be viewed from a position where the tape guide assembly faces up and the backspace lever is to the viewer's left. Orientation references in the drive link mechanism area consider the drive link to be up and located to the viewer's left.

CAUTION: DO NOT USE ALCOHOL, MINERAL SPIRITS, OR OTHER SOLVENTS TO

CLEAN PLASTIC PARTS OR PARTS WITH PROTECTIVE - DECORATIVE FINISHES. NORMALLY, A SOFT, DRY CLOTH SHOULD BE USED TO REMOVE DUST, OIL, GREASE, OR OTHERWISE CLEAN PARTS OR SUBASSEMBLIES. IF NECESSARY, A SOFT CLOTH DAMPENED WITH SOAP OR MILD DETERGENT MAY BE USED. AFTERWARDS, RINSE EACH CLEANED PART OR SUBASSEMBLY WITH A SOFT, DAMP CLOTH AND BUFF WITH A SOFT, DRY CLOTH.

2. BASIC UNIT

2.01 Tape Punch

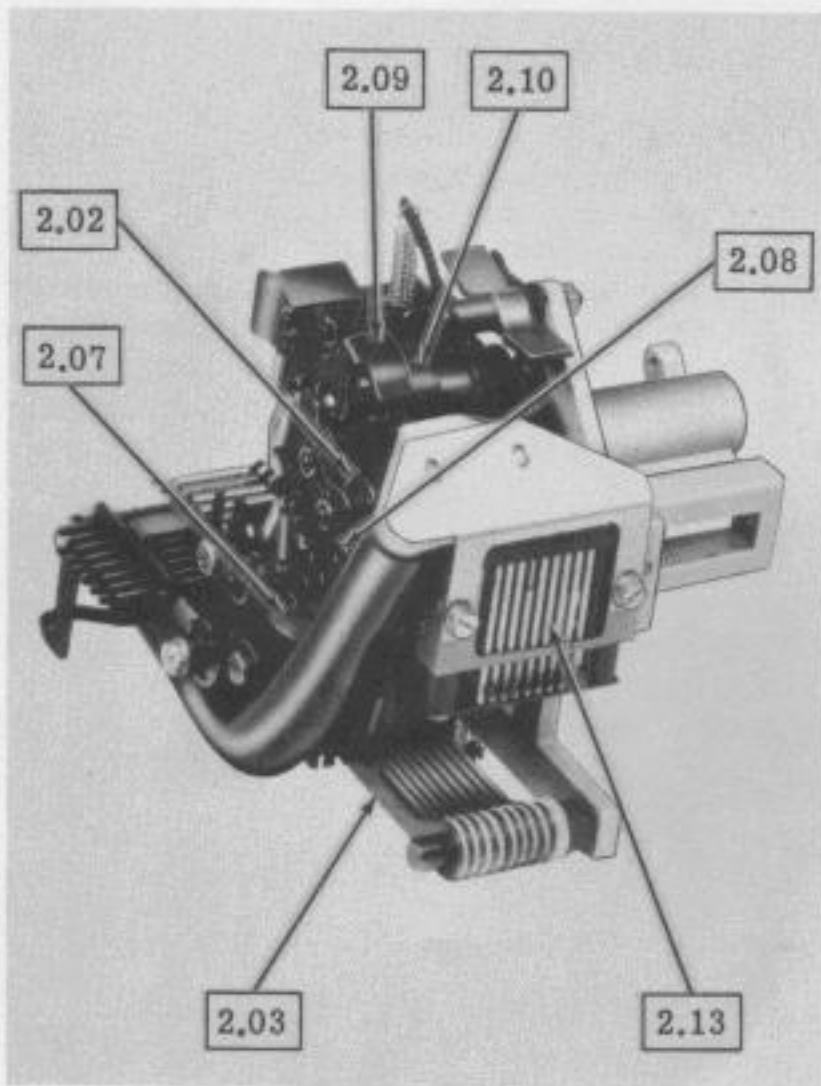

(LEFT FRONT VIEW)

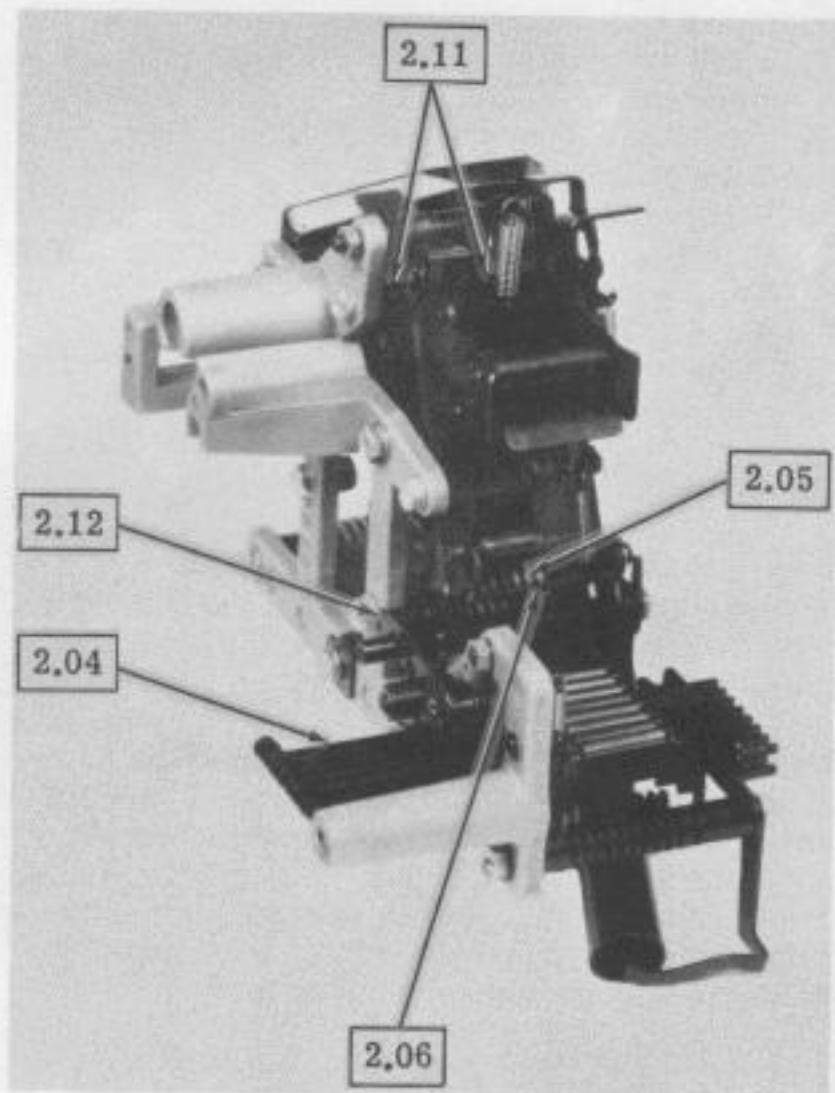

(RIGHT REAR VIEW)

2.02 Feed Mechanism

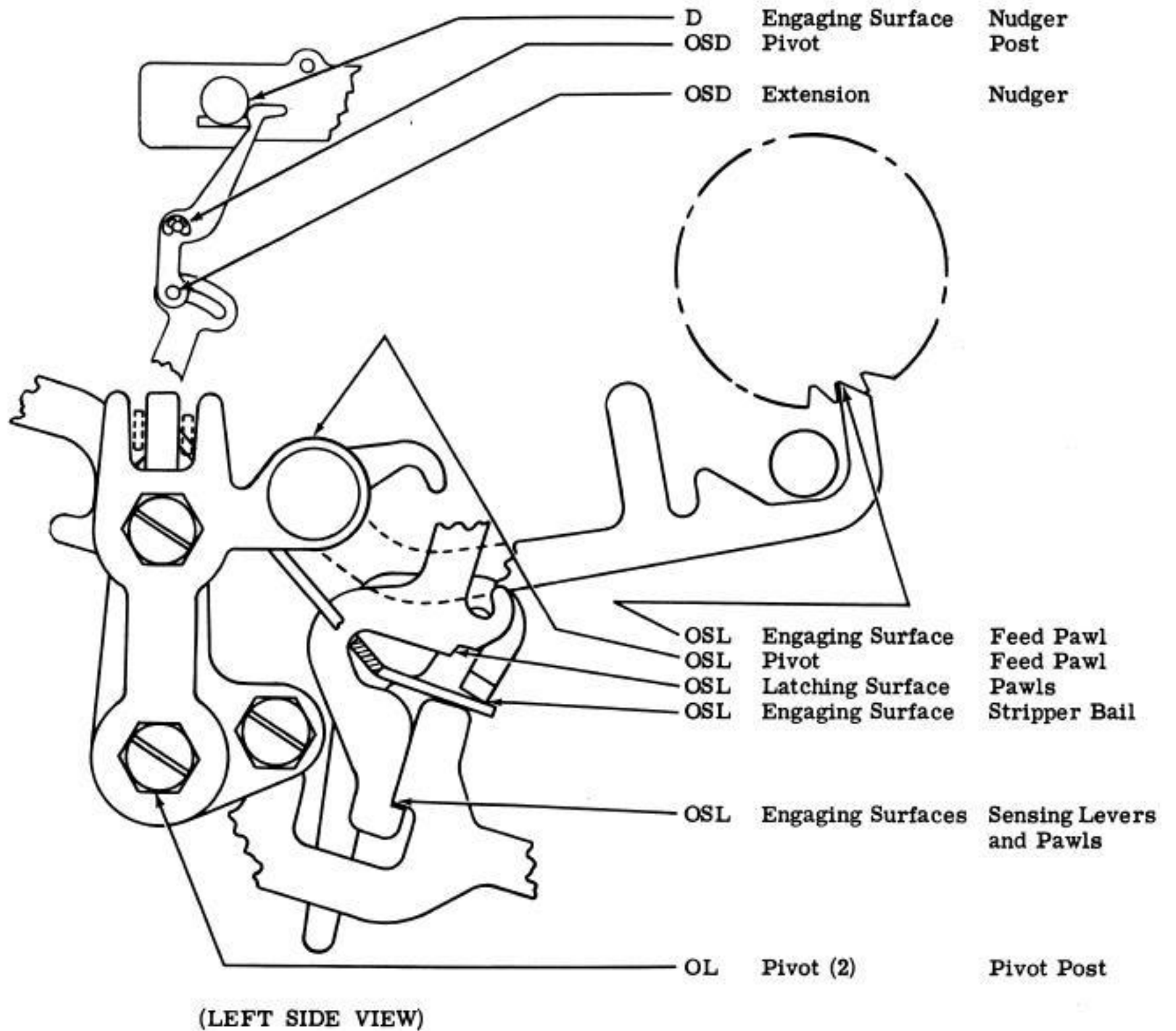

2.03 Sensing Levers

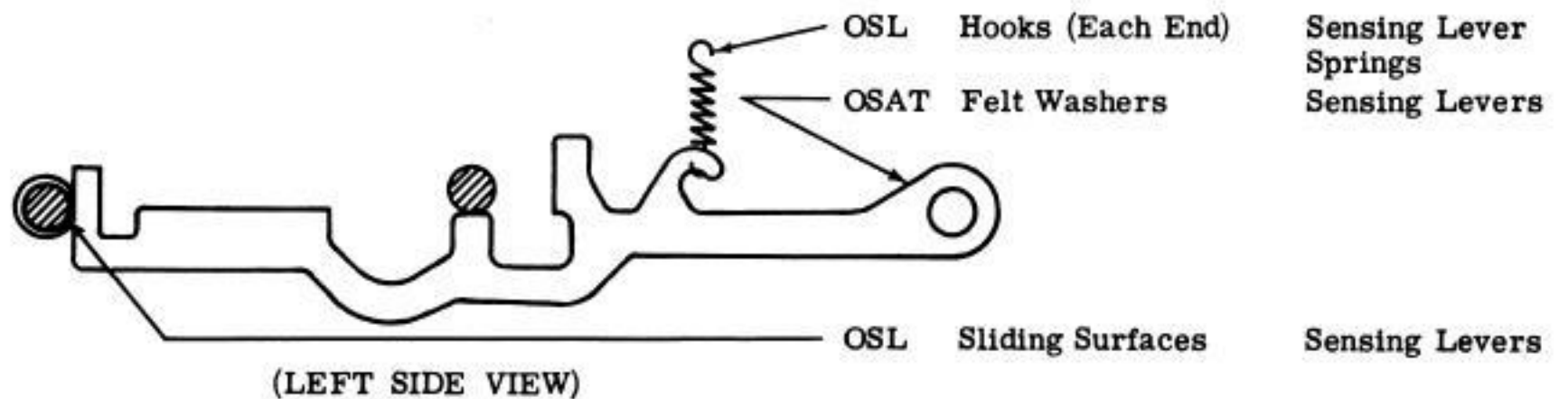

2.04 Codebar Levers

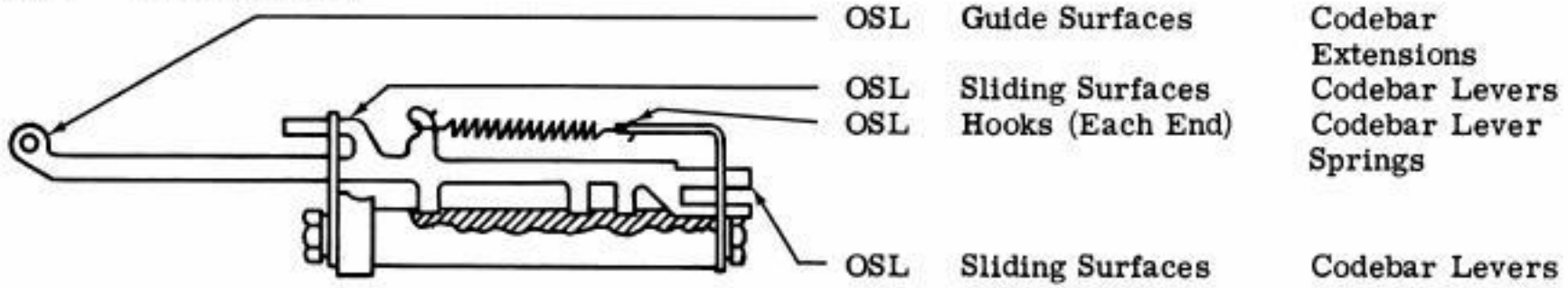

(REAR VIEW)

2.05 Pawls and Levers

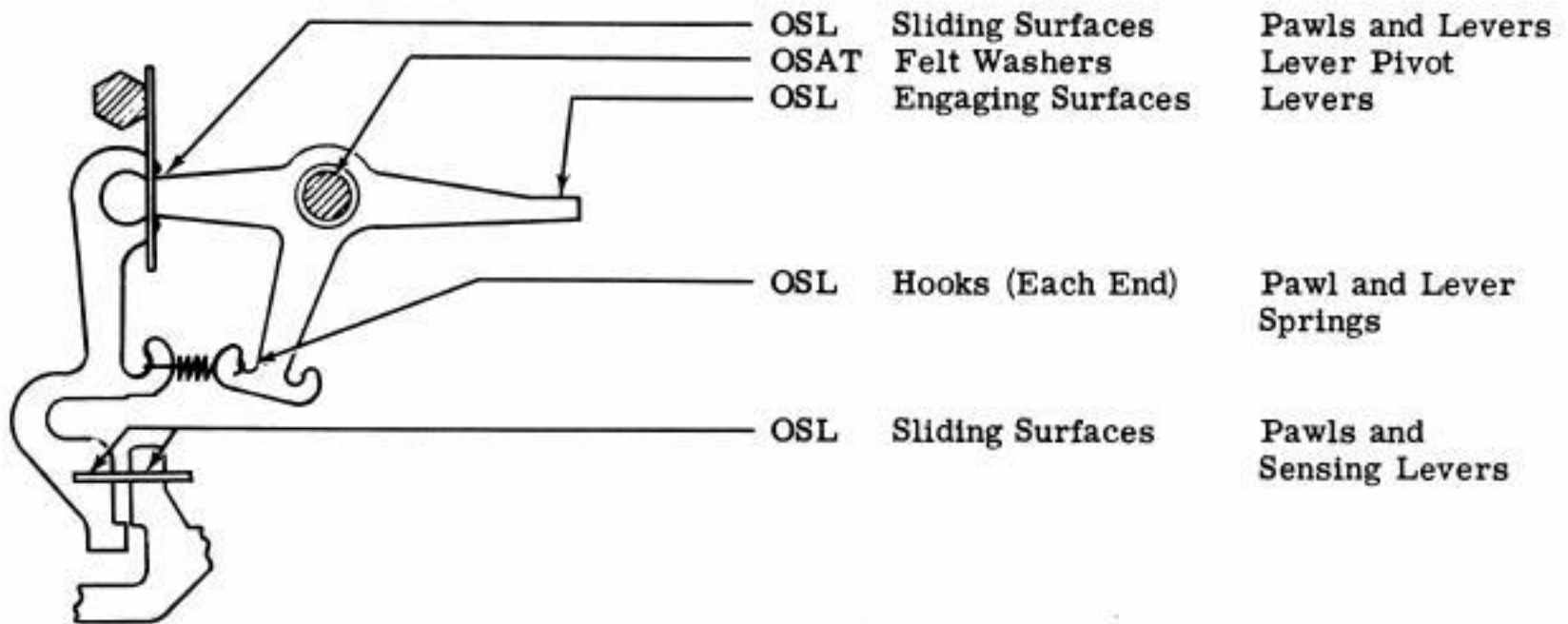

(LEFT SIDE VIEW)

2.06 Stripper Bail

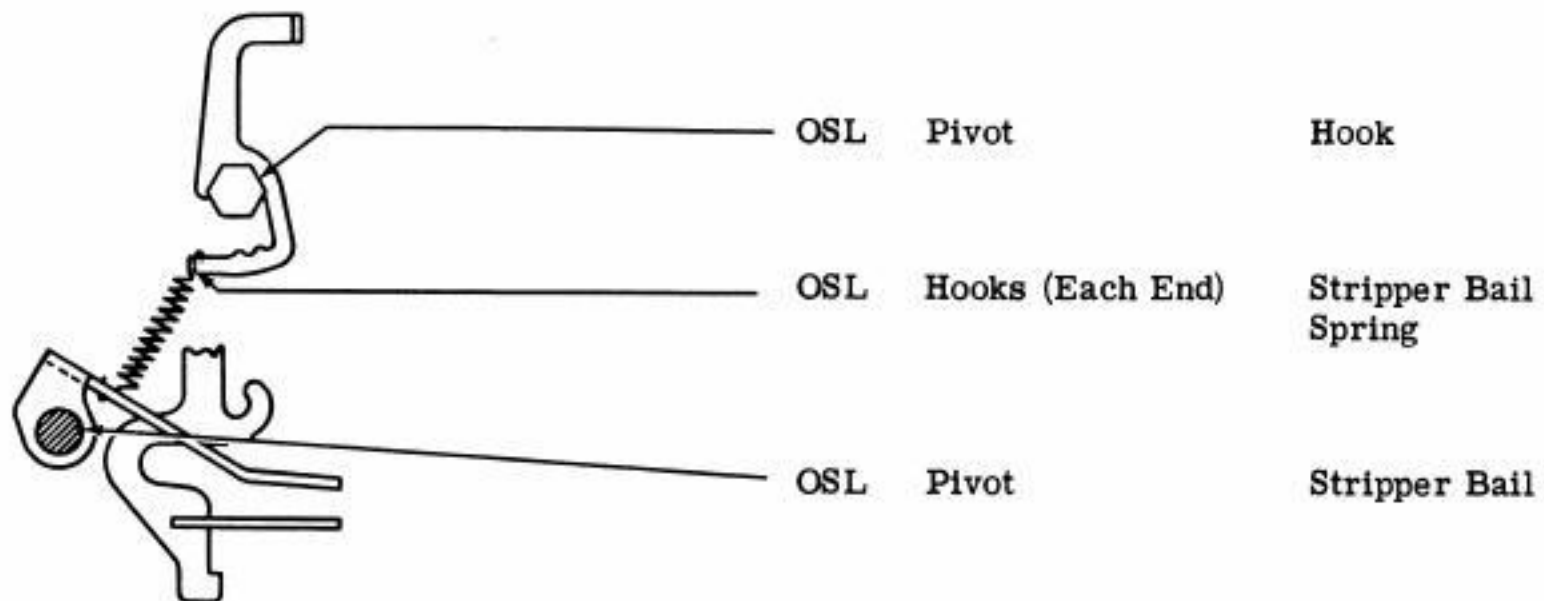

(LEFT SIDE VIEW)

2.07 Feed Pawl

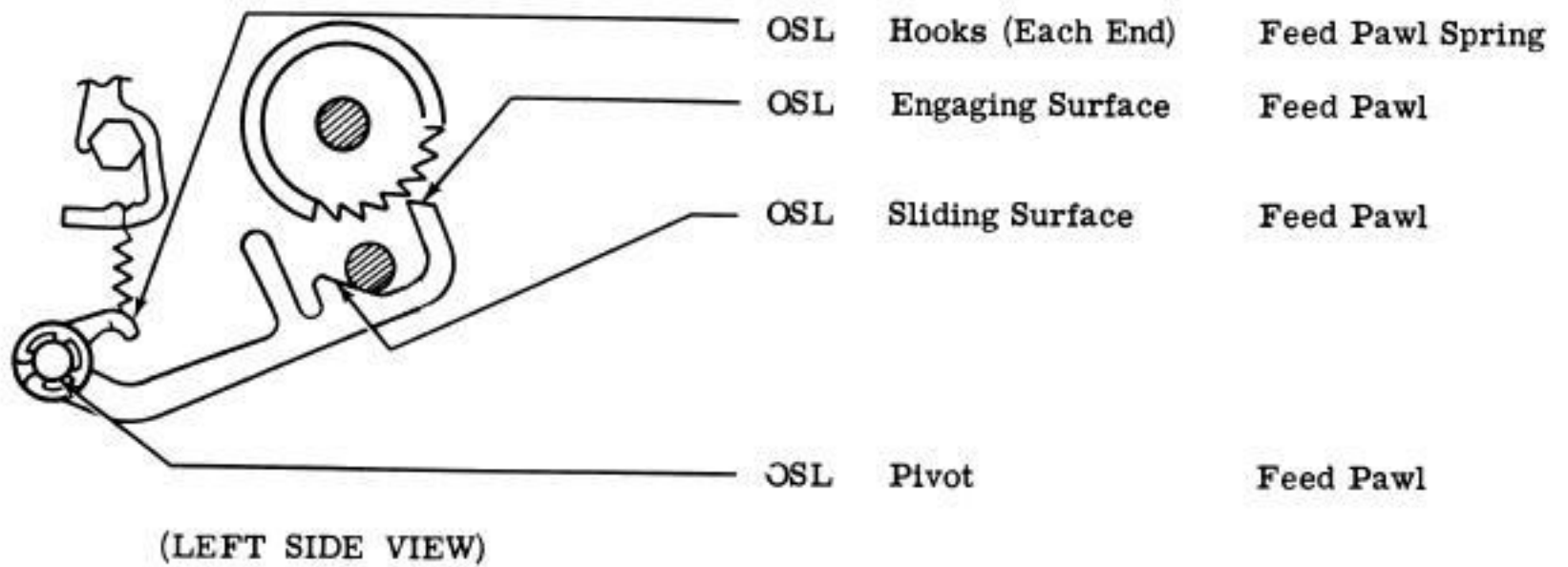

2.08 Detent Lever

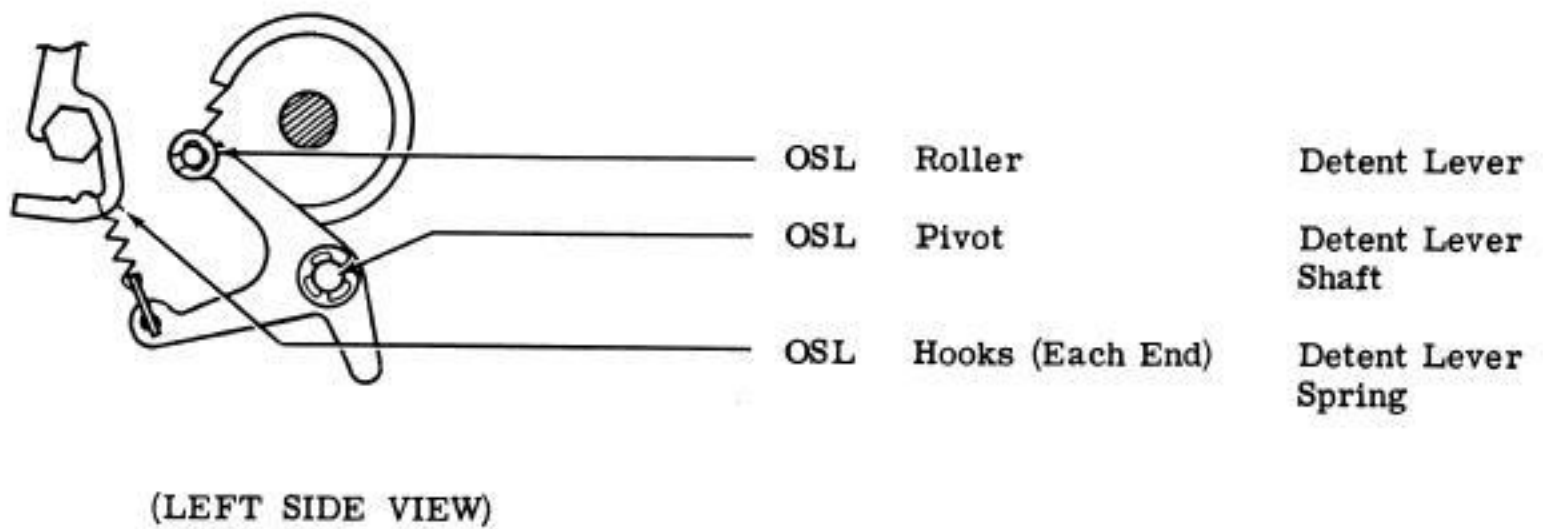

2.09 Backspace Lever

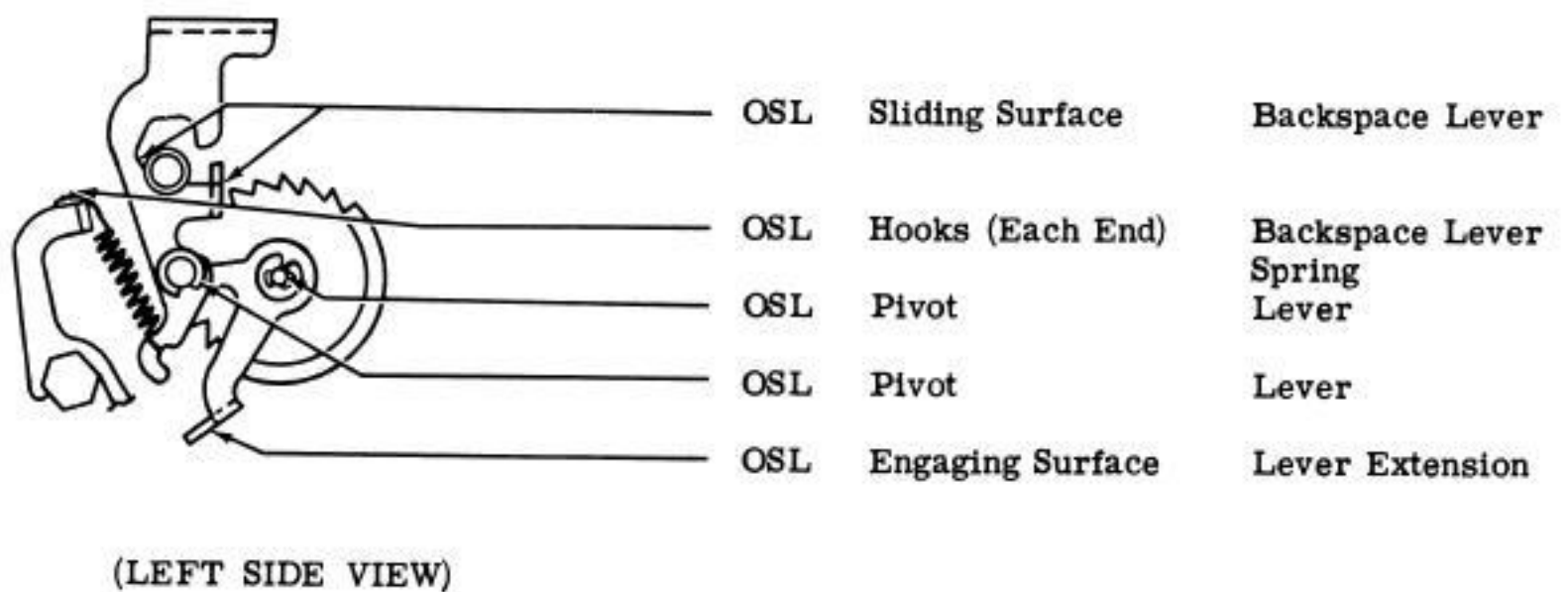

2.10 Tape Guide Assembly

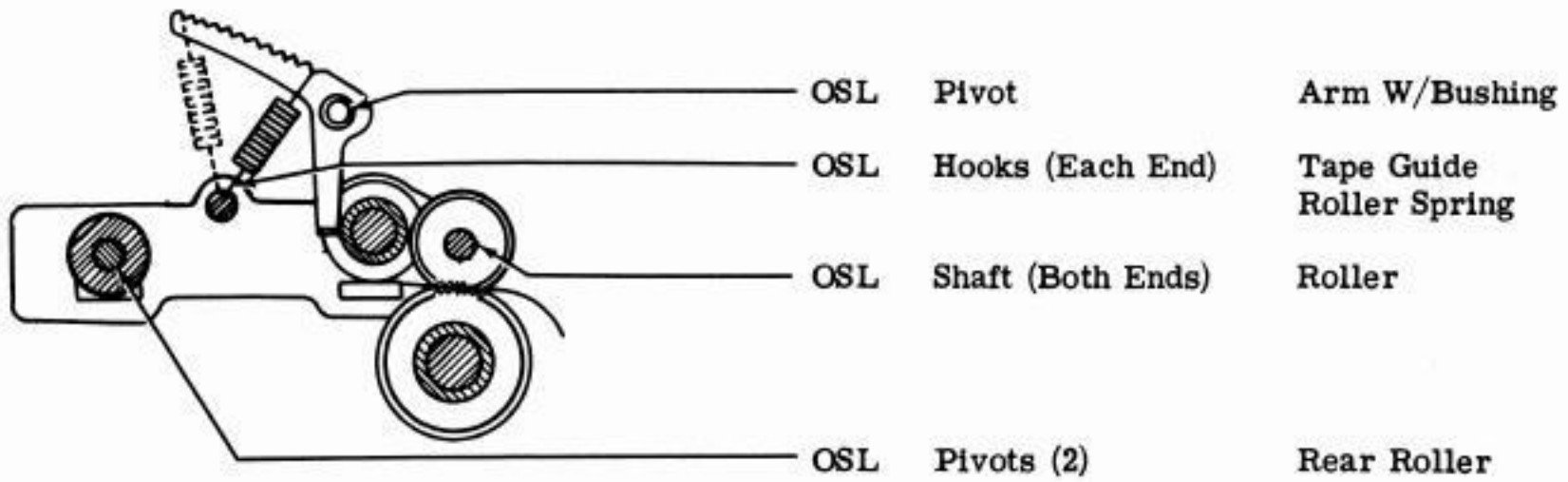

(LEFT SIDE VIEW)

2.11 Tape Guide Roller

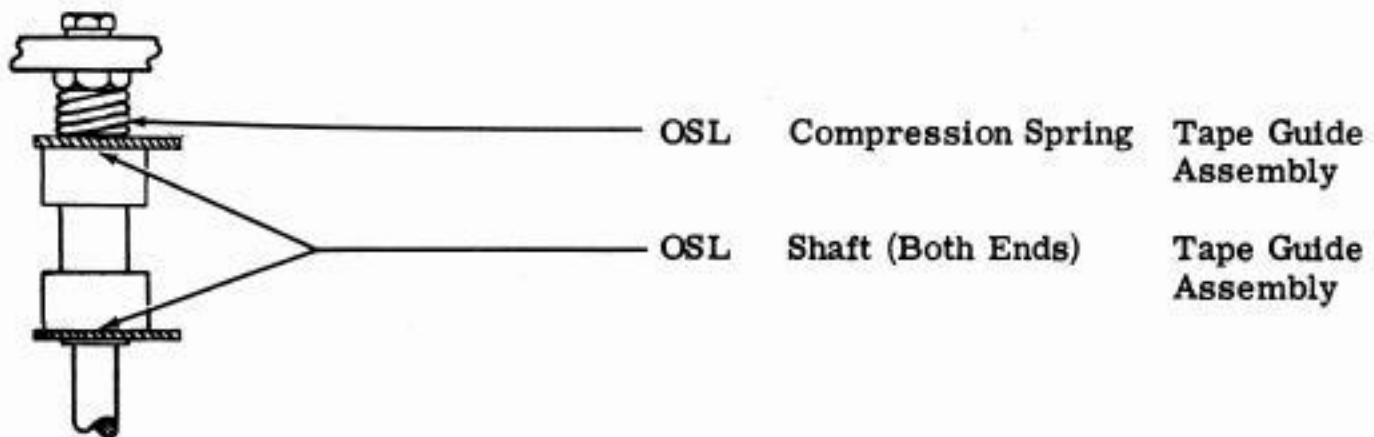

(TOP VIEW)

2.12 Control Mechanism

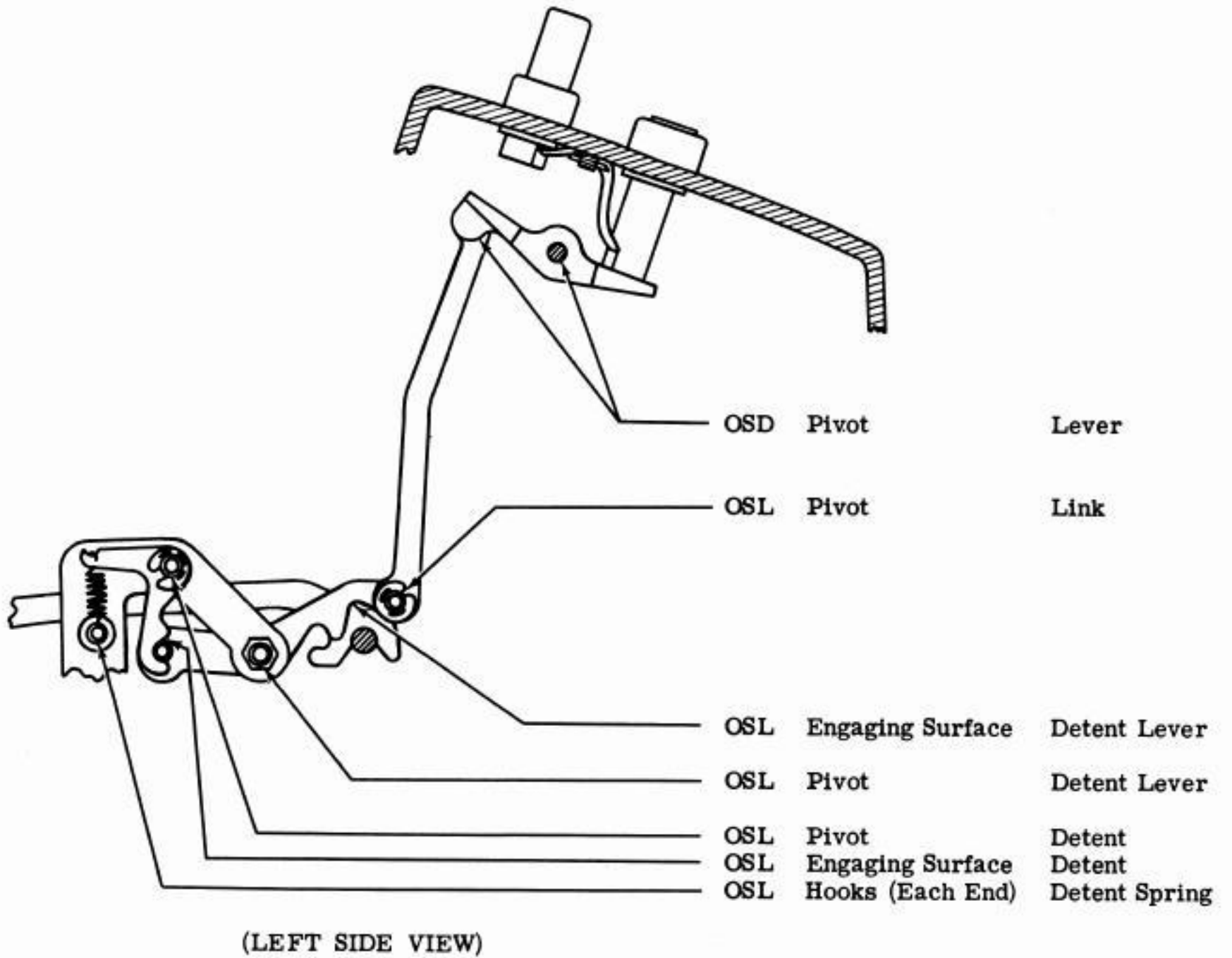

2.13 Punch Block Assembly

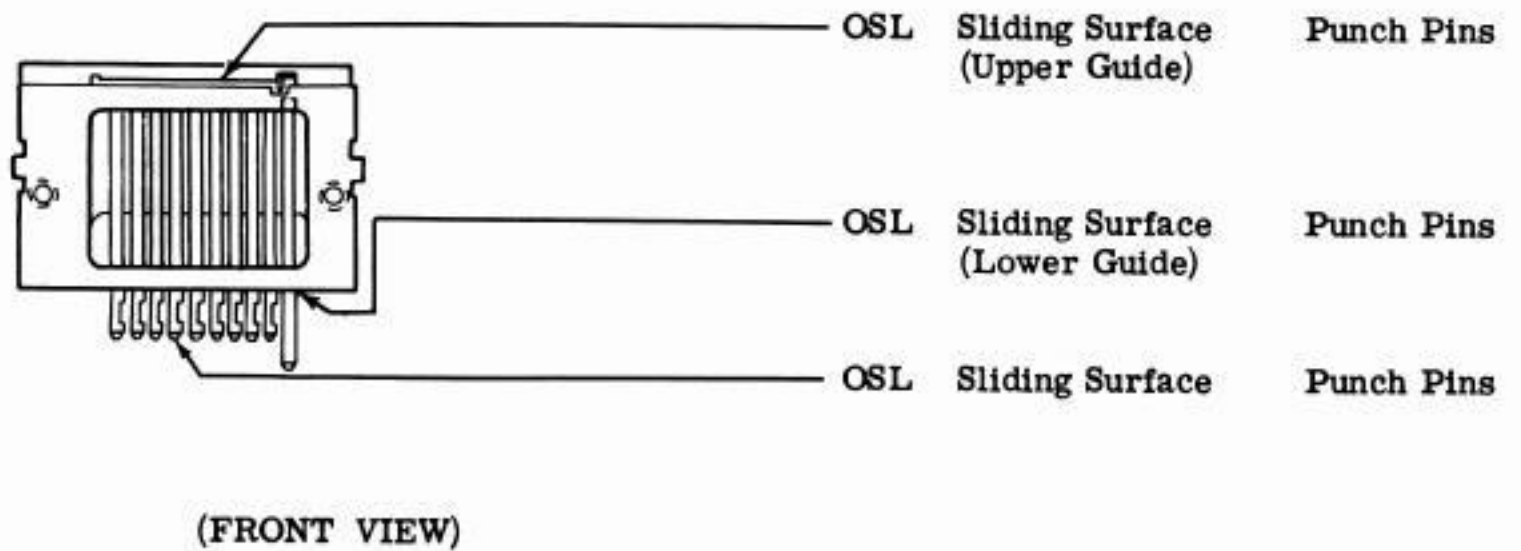

2.14 Drive Link Mechanism Area

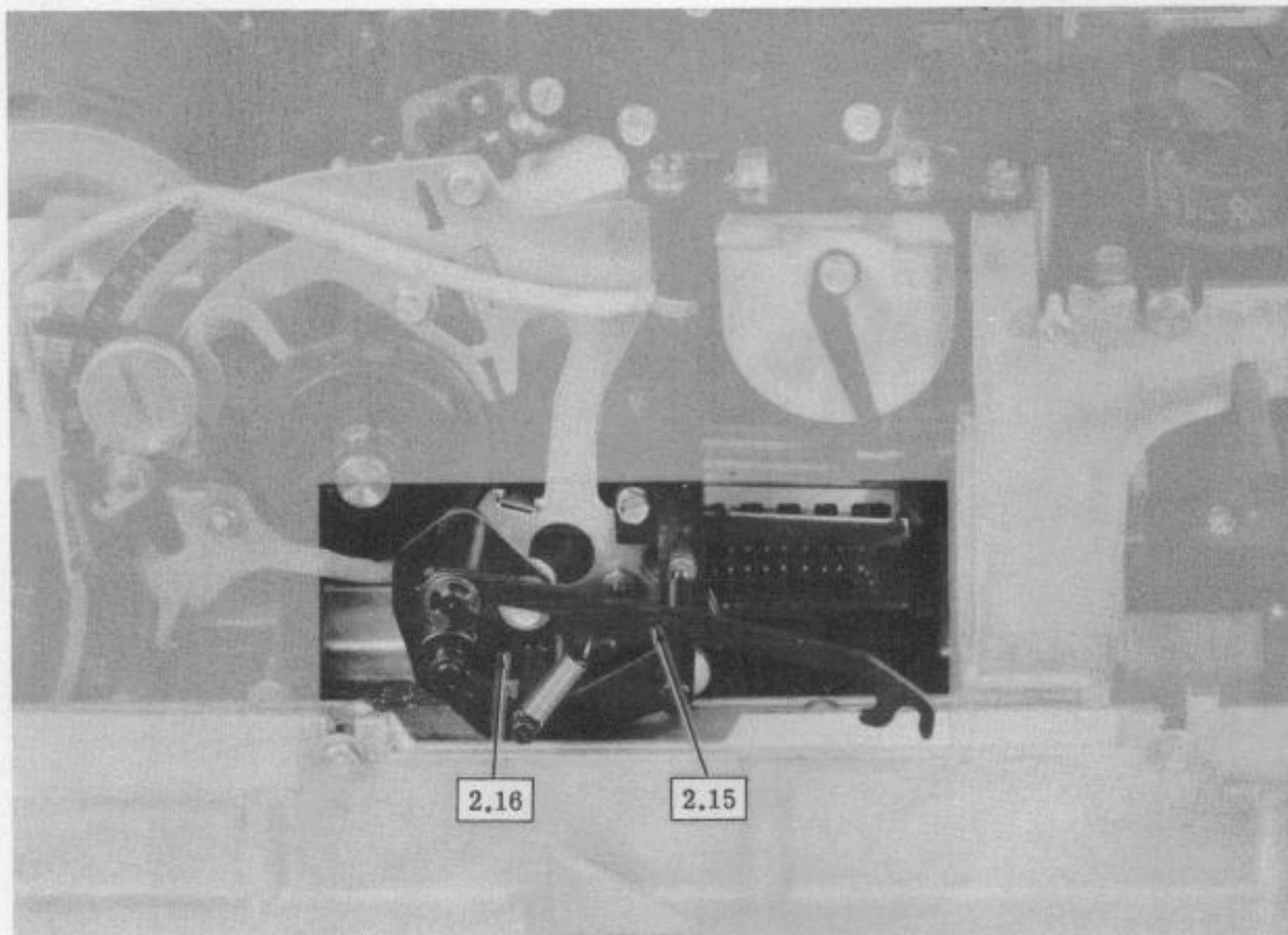

(LEFT SIDE VIEW)

2.15 Drive Link

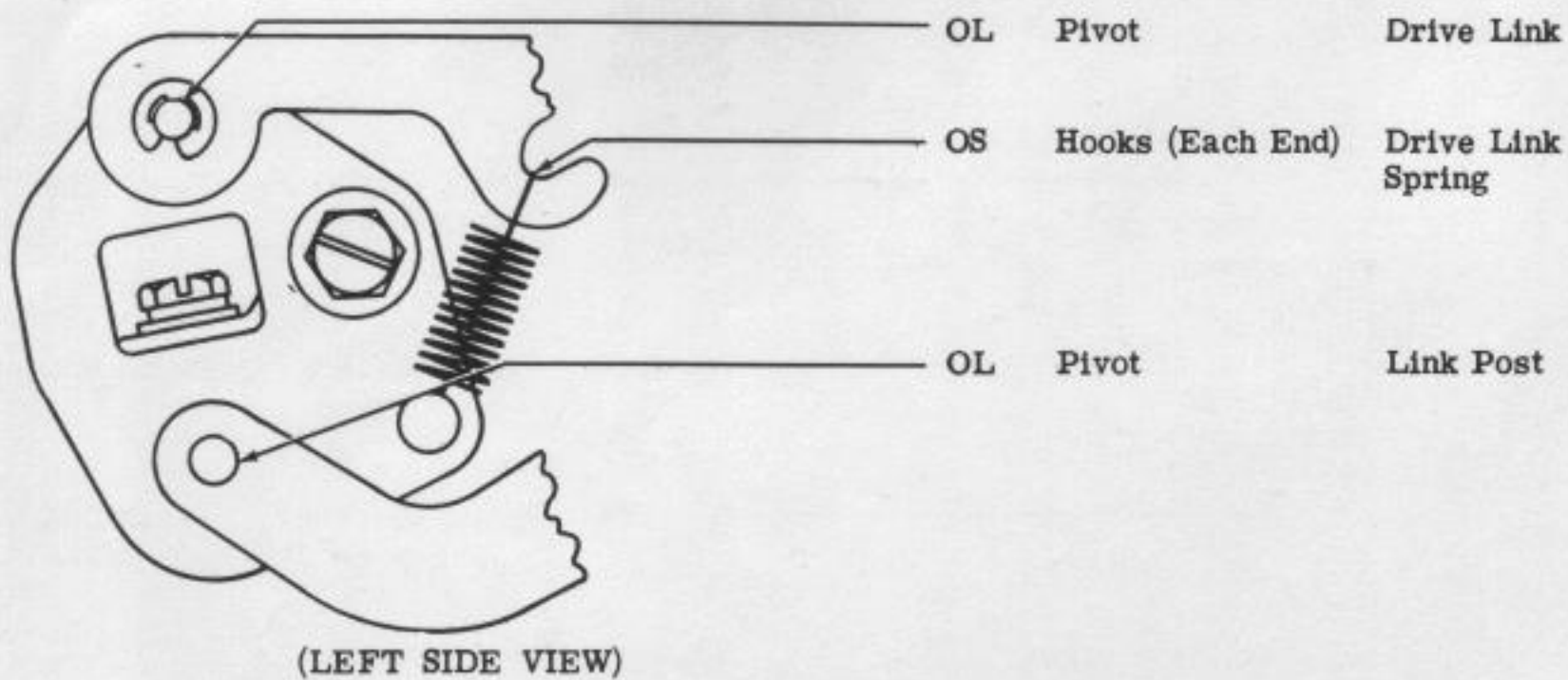

2.16 Drive Link Mechanism

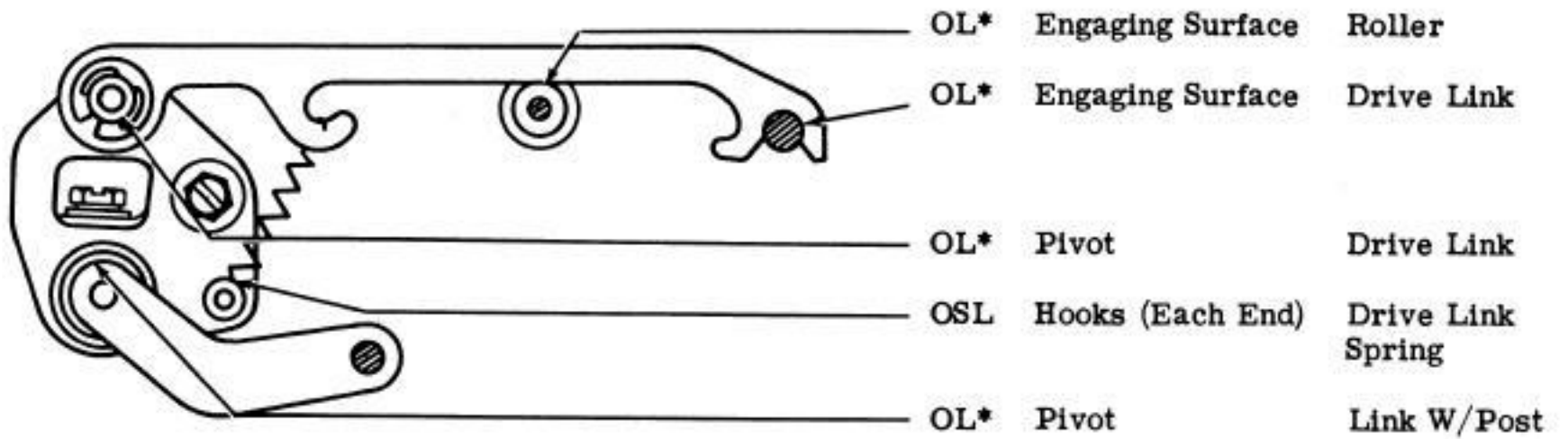

(LEFT SIDE VIEW)

*GOL when assembly is overhauled.