

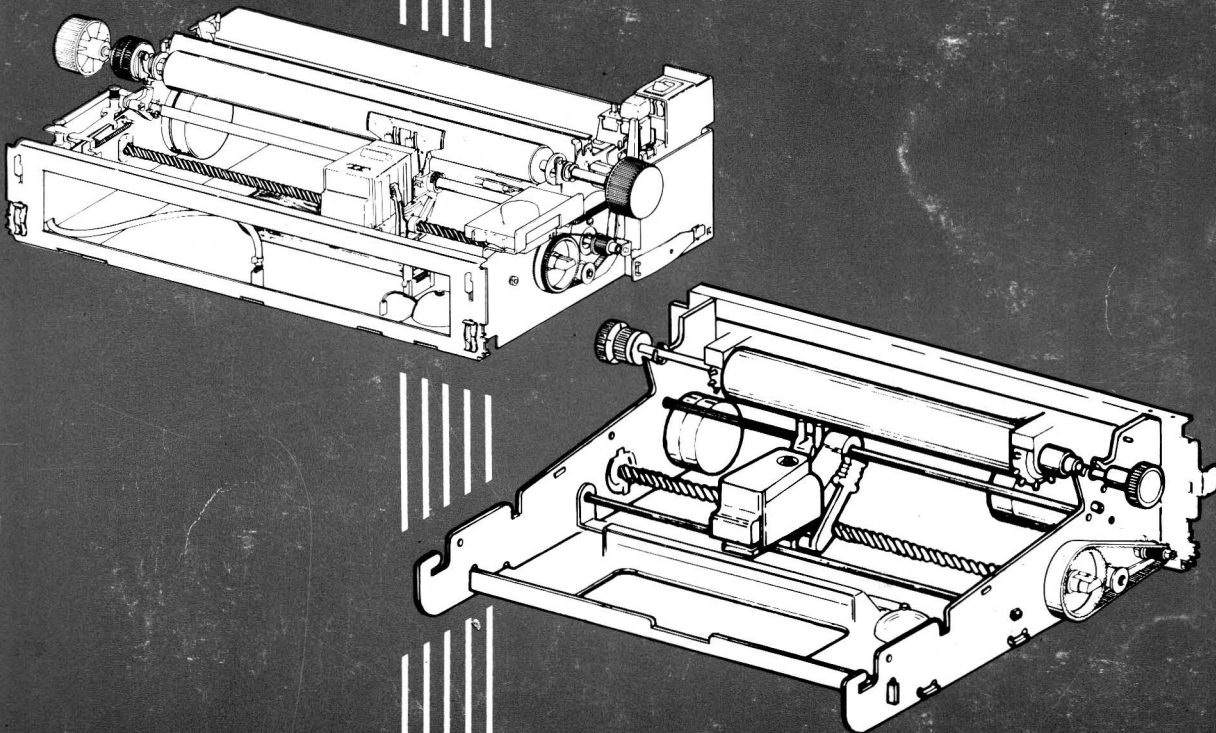

TELETYPE  
CORPORATION

**REPAIR  
MANUAL  
539**



for  
**42, 43 and 45  
30 CPS CHARACTER PRINTER  
MECHANISMS**



Teletype Corporation Product Service and Education Services

On the following page is a list of Teletype Corporation Product Service locations which provide maintenance service and repair on all Teletype Corporation products. For more information call toll free (US 800-323-4226) (IL 800-942-4192) 7:00 A.M. — 4:00 P.M. CST.

In addition, Teletype Corporation provides Customer Technical Training at its headquarters at 5555 W. Touhy Avenue, Skokie, IL in the northwest suburban area of Chicago. The training covers the installation, maintenance and repair of all Teletype Corporation products. Arrangements can also be made for training to be conducted at customer-selected field sites.

For information about class schedules, enrollment, tuition, on-site training or any special training needs, please contact:

Technical Training Center  
Staff Manager - Operations Support  
Teletype Corporation  
5555 W. Touhy Avenue  
Skokie, Illinois 60077  
Telephone (312) 982-3940  
TLX 25-4051  
TWX 901-223-3611

# Teletype Corporation

## Product Service The Complete Resource

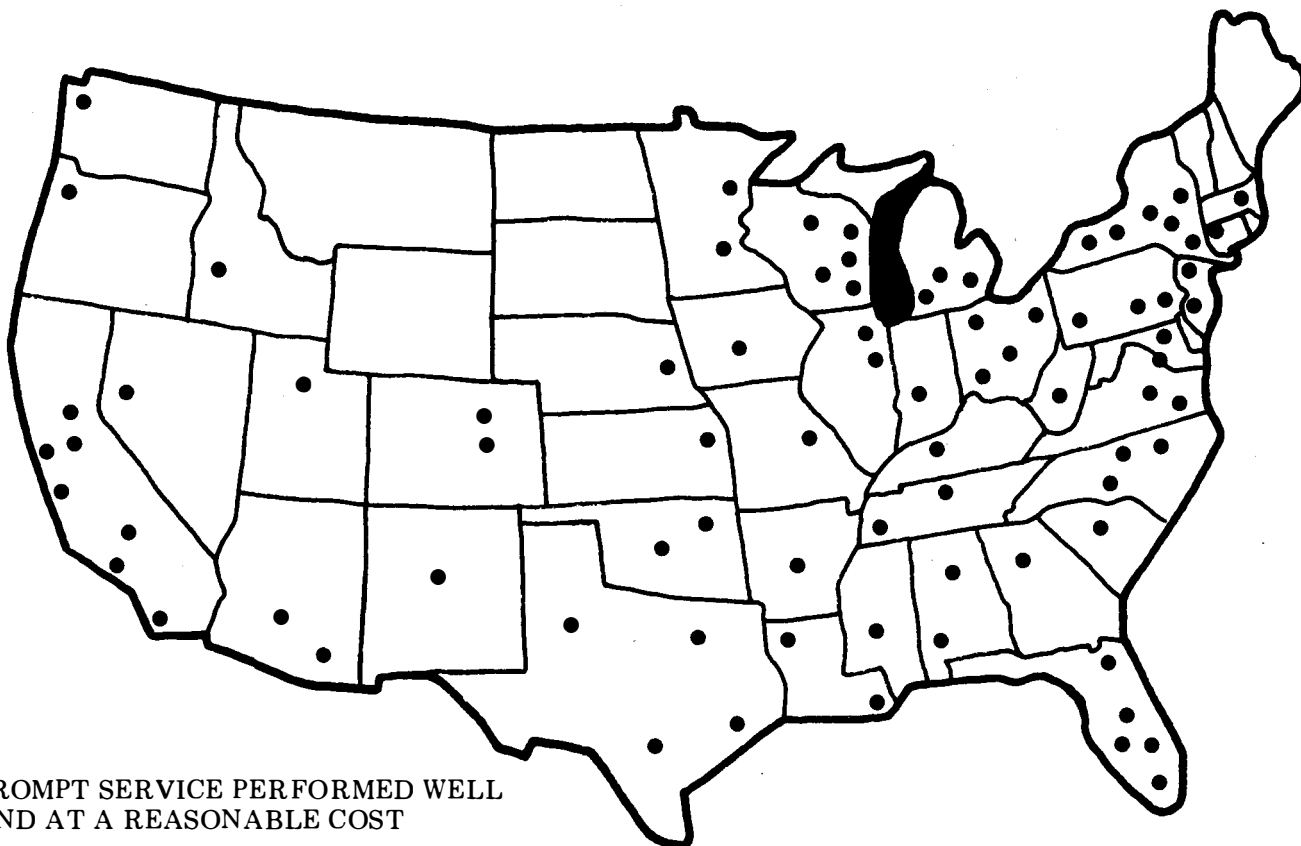

PROMPT SERVICE PERFORMED WELL  
AND AT A REASONABLE COST

Even the best equipment can fail at some time. When failures occur, you want prompt service, because down time is expensive. You want service performed well -- and at a reasonable cost. With Teletype® Product Service Centers located throughout the United States and Canada, and our National Central Dispatch System available around the clock, every day of the year, you know we rate customer service as our primary goal.

### A TOTAL SUPPORT EFFORT

Our service representatives are professional, employed and trained by Teletype Corporation. They know our equipment inside out, and can locate and repair problems quickly and effectively. These skilled technicians are backed by an array of sophisticated test equipment, a multi-million dollar parts inventory, and full engineering support. Only the manufacturer of equipment being serviced can offer this total support effort . . . Teletype Corporation Product Service . . . the complete resource.

### NATIONAL SERVICE NETWORK

Albany	Greensboro	Orange County
Albuquerque	Harrisburg	Orlando
Appleton	Hartford	Philadelphia
Atlanta	Houston	Phoenix
Baltimore	Indianapolis	Pittsburgh
Birmingham	Jackson	Portland
Boise	Jacksonville	Reno
Boston	Kalamazoo	Richmond
Buffalo	Kansas City	Rochester
Charleston	Lansing	Sacramento
Charlotte	Little Rock	Salt Lake City
Chicago	Long Island	San Antonio
Cincinnati	Los Angeles	San Diego
Cleveland	Louisville	Santa Clara
Colorado Springs	Lubbock	Seattle
Columbia	Madison	Shreveport
Columbus	Memphis	St. Louis
Dallas	Miami	Syracuse
Decatur	Milwaukee	Tampa
Denver	Minneapolis	Toledo
Des Moines	Mobile	Toronto
Detroit	Nashville	Tucson
Duluth	New Orleans	Tulsa
Durham	New York	Ventura
Eau Claire	Norfolk	Washington
Edison	Oakland	Wausau
Fairfield	Oklahoma City	
Fort Lauderdale	Omaha	

Call Toll Free 800/323-4226

In Illinois 800/942-4192

In Canada, call 416/745-9474

## 43, 43 AND 45-30 CPS CHARACTER PRINTER MECHANISMS

### REPAIR MANUAL

### INTRODUCTION

This manual provides repair information for 42, 43 and 45-30 CPS Character Printer Mechanisms. The manual is intended for field and shop use and is arranged into various parts that include troubleshooting, disassembly/reassembly, adjustments and spring tensions, wiring, lubrication, parts and print head packing information.

Testing is not included in this manual. Therefore printer mechanisms should be tested as part of the teleprinter and troubles are isolated to major areas using the appropriate service manual for the teleprinter. Troubles are isolated within the printer mechanisms in this manual.

The task flow chart on the next page illustrates the intended repair activities and the associated manual parts.

Service parts for repair are available from Teletype Corporation. Service personnel should be properly trained and have access to these parts before attempting repair or printer mechanisms. Contact Teletype Corporation Technical Training Center, Staff Manager-Operations Support, 312-982-3941 for repair courses available.

REPAIR MANUAL FOR  
42, 43 AND 45-30 CPS CHARACTER PRINTER  
MECHANISMS

TABLE OF CONTENTS

PART 1	TESTING
PART 2	TROUBLESHOOTING
PART 3	DISASSEMBLY/REASSEMBLY
PART 4	ADJUSTMENTS AND SPRING TENSIONS
PART 5	WIRING
PART 6	LUBRICATION
PART 7	PARTS
PART 8	PRINT HEAD PACKING

TASK FLOW CHART

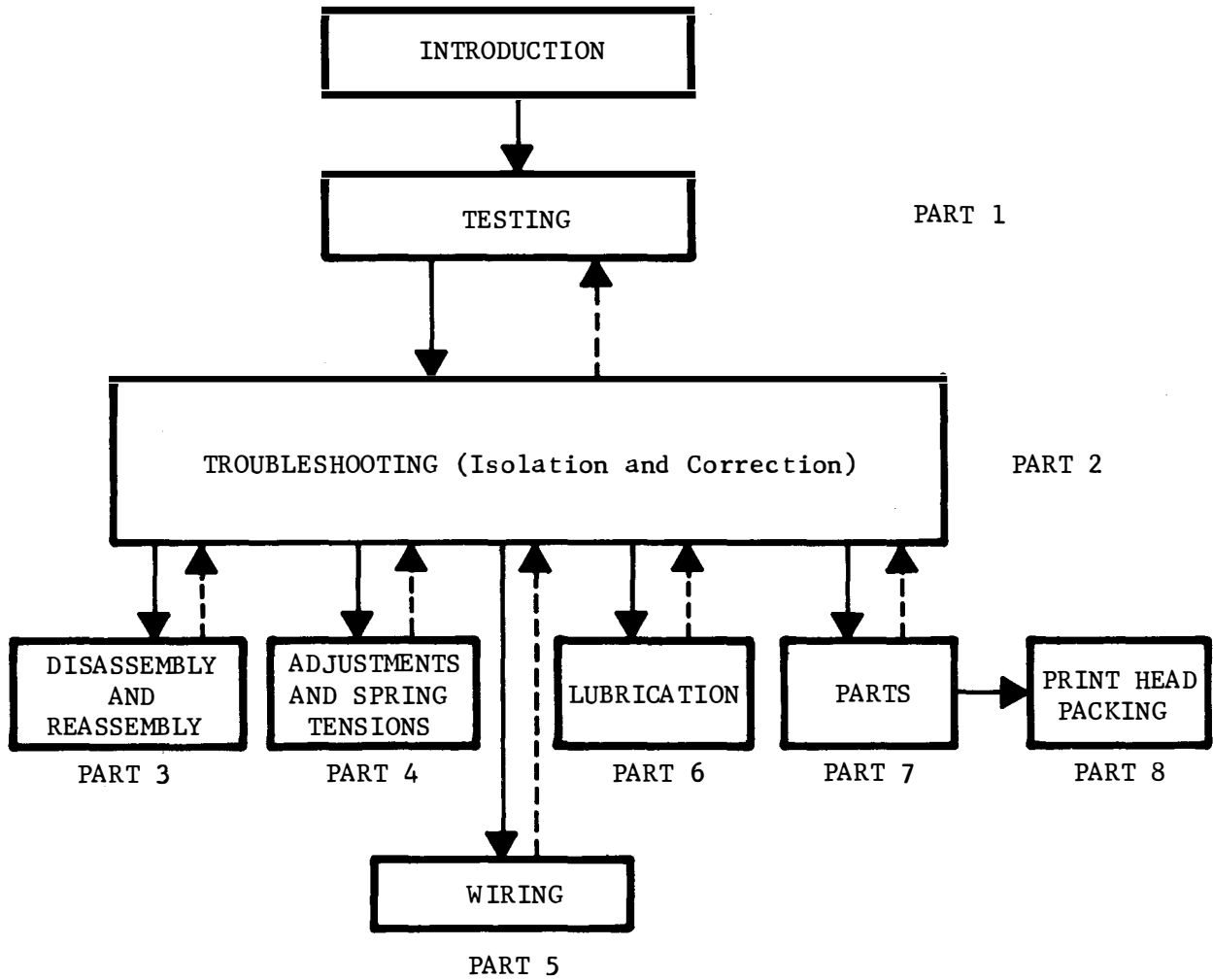

PART 1 -- TESTING

Refer to the appropriate service manual for testing information. In the service manual, testing is performed at a terminal level and troubleshooting is based on isolation of troubles to major components.

The list below indicates the printer mechanisms and their associated service manual to date:

<u>PRINTER MECHANISM</u>	<u>SERVICE MANUAL NUMBER</u>	<u>SERVICE MANUAL DESCRIPTION</u>
12 Inch Friction Feed	538*	42 Basic Teleprinter
12 Inch Pin and Friction Feed	369	43 Basic Teleprinter
12 Inch Pin and Friction Feed	406	43 Buffered KSR
12 Inch Pin and Friction Feed	425	42 Buffered KSR
12 Inch Pin and Friction Feed	468*	43 Buffered KSR Selective Calling
12 Inch Pin and Friction Feed	482*	42 Buffered KSR Selective Calling
12 Inch Tractor Feed	369, Issue 4 or later*	43 Basic Teleprinter
12 Inch Tractor Feed	406, Issue 3 or later*	43 Buffered KSR
12 Inch Tractor Feed	425, Issue 2 or later*	42 Buffered KSR
12 Inch Tractor Feed	468*	43 Buffered KSR Selective Calling
12 Inch Tractor Feed	482*	42 Buffered KSR Selective Calling
15 Inch Tractor Feed	499*	15 Inch 30 CPS Character Matrix Printer

\*Until the manuals listed above are available, testing should be performed using the How to Operate manual associated with the teleprinter.



PART 2 – TROUBLESHOOTING

	<u>CONTENTS</u>	<u>PAGE</u>
A.	GENERAL .....	2-1
B.	12 INCH SPROCKET (PIN) AND FRICTION FEED PRINTER TROUBLESHOOTING GUIDE. ....	2-2
C.	12 INCH TRACTOR FEED PRINTER TROUBLESHOOTING GUIDE. ....	2-4
D.	15 INCH TRACTOR FEED PRINTER TROUBLESHOOTING GUIDE. ....	2-7

A. GENERAL

This part provides troubleshooting information for the 12 inch friction feed, sprocket (pin) feed and tractor feed printer mechanisms and the 15 inch tractor feed printer mechanism.

Printer troubleshooting is initiated either by the associated teleprinter troubleshooting sections in the applicable service manual or when trouble in the printer is suspected from symptoms observed.

Trouble analysis is presented in the form of a "20 Questions" routine in the Troubleshooting Guides. The guides, with questions and yes or no columns, should be used always starting with the first question and proceeding according to the "Yes" or "No" directive.

**B. 12 INCH SPROCKET (PIN) AND FRICTION FEED PRINTER TROUBLESHOOTING GUIDE**

QUESTION	YES	NO
1. Does test message print and paper advance properly while PRINTER TEST key is depressed? (or switch on logic card is operated on)	Go to 2.	Go to 1a.
1a. Does carriage space and return properly?	Go to 1b.	<p>Check for mechanical bind by moving carriage manually with power off.</p> <p>Check for proper spacing belt spring tension.</p> <p>Check platen end play adjustment.</p> <p>Check continuity of spacing motor and encoder.</p> <p>Check switch on print head circuit card.</p> <p>Replace spring motor and/or encoder or cable.</p> <p>Replace lead screw nut.</p>
1b. Does paper advance properly? (Successive lines uniformly spaced)	Go to 1c.	<p>Check line feed belt tension.</p> <p>Check for mechanical bind by rotating platen manually with power off.</p> <p>Check platen end play adjustment.</p> <p>Check line feed follower pulley stop bracket and pressure roller bail adjustment (friction feed).</p> <p>With power on (reset) check platen detenting through full rotation by turning platen knob.</p> <p>Check continuity of line feed motor.</p> <p>Replace motor or cable parts.</p>
1c. Sprocket Feed — Do sprocket pins on platen line up with paper and with paper guides?	Go to 1d.	<p>Check left and right sprocket adjustment.</p> <p>Check left and right paper guide adjustment.</p>
1d. Are any characters printed?	Go to 1e.	Check continuity of print head and cable.

QUESTION	YES	NO
1e. Are any dots missing from printed characters?	<p>Check print head for: open coil, cracked wire guides, split or missing armature sleeves.</p> <p>Check print head armature adjustment.</p> <p>Replace print head or cable.</p>	Go to 1f.
1f. Are any dots noticeably out of line on characters with vertical segments.	<p>Examine print head wire guides for cracks or wear.</p> <p>Replace print head.</p>	Go to 1g.
1g. Are characters excessively compressed or expanded horizontally?	<p>Check for loose encoder disc.</p> <p>Check for excessive play between lead screw and nut.</p> <p>Replace lead screw nut.</p>	Go to 1h.
1h. Is proper print density obtained (good ribbon, proper multi-copy paper)?	Go to 1i.	<p>Check print head to platen adjustment.</p> <p>With power off and carriage moved manually, check that ribbon moves with carriage without slipping during return and does not move when carriage is moved to the right.</p> <p>Check carriage and left bracket ribbon rollers for "one way" rotation.</p>
1i. Sprocket Feed — Does printed copy align properly with edge of paper (prints equally on each side of page perforation)?	<p>Undefined problem during PRINTER TEST.</p> <p>Go to Teleprinter Troubleshooting in Service Manual.</p>	Check printed line position adjustment.
2. Did bell ring during PRINTER TEST.	Go to 3.	Go to 2a.
2a. Does bell ring under any conditions (CTRL G R.H. margin, etc)?	Go to Teleprinter Troubleshooting in Service Manual.	<p>Check bell coil and cable continuity.</p> <p>Check for freedom of bell plunger.</p>
3. Sprocket Feed — Does ALARM indicator light when a paper out condition is sensed?	<p>Undefined trouble.</p> <p>Go to Teleprinter Troubleshooting in Service Manual.</p>	<p>Check continuity of paper out cable and contacts.</p> <p>Check paper alarm contact adjustment.</p>

C. 12 INCH TRACTOR FEED PRINTER TROUBLESHOOTING GUIDE

QUESTION	YES	NO
1. Does test message print and paper advance properly while <b>PRINTER TEST</b> key is depressed (or switch on logic card) is operated?	Go to 2.	Go to 1a.
1a. Is red lamp on power supply lit?	Go to 1b.	Go to Teleprinter Troubleshooting in Service Manual.  Check circuit in printer that failed for shorts.
1b. Does anything print or perform?	Go to 1c.	Go to Teleprinter Troubleshooting in Service Manual.
1c. Does carriage space and return properly?	Go to 1d.	Check for mechanical bind by moving carriage manually with power off. Check for proper lead screw lubrication. Check for proper spacing belt spring tension. Check continuity of spacing motor and encoder. Check switch on print head. Replace motor and/or encoder or cable. Replace lead screw nut.
1d. Does paper advance properly (successive lines uniformly spaced)?	Go to 1e.	Check for mechanical bind by rotating platen manually with power off. Check for both tractor rotation as platen knob is rotated. Check <b>PLATEN END PLAY</b> adjustment. Check line feed motor gear backlash. Check idler gear to platen gear backlash. With power on (reset) check platen detenting through full rotation by turning platen knob. Check continuity of line feed motor. Replace motor or cable.

QUESTION	YES	NO
1e. Do tractor pins line up with paper holes?	Go to 1f.	Check paper specifications.
1f. Are any characters printed?	Go to 1g.	Check continuity of print head and cable. Go to Teleprinter Troubleshooting in Service Manual.
1g. Are any dots missing from printed characters?	Check continuity of associated print magnet.  Check <u>PRINT HEAD ARMATURE</u> adjustment.  Replace print head or cable.	Go to 1h.
1h. Are any dots noticeably out of line on characters with vertical segments?	Replace print head.	Go to 1i.
1i. Is proper print density obtained (good ribbon, proper multicopy paper)?	Go to 2.	Check <u>PRINT HEAD TO PLATEN</u> adjustment.  With power off and carriage moved manually, check that ribbon moves with carriage during return but does not move when carriage is moved to the right.  Check left bracket ribbon rollers for "one way" rotation.
1j. Does printed copy align properly with edge of paper (prints equally on each side of page perforation)?	Undefined problem during <u>PRINTER TEST</u> .  Go to Teleprinter Troubleshooting in Service Manual.	Reposition tractors.  Readjust left margin vernier.

## C. 12 INCH TRACTOR FEED PRINTER TROUBLESHOOTING GUIDE (Contd)

QUESTION	YES	NO
2. Did bell ring during PRINTER TEST?	Go to 3.	Go to 2a.
2a. Does bell ring under any conditions (on power turn on)?	Go to Teleprinter Troubleshooting in Service Manual.	Check bell coil and cable continuity.  Check for freedom of bell plunger.
3. Does ALARM indicator light when a paper-out condition is sensed?	Undefined trouble.  Go to Teleprinter Troubleshooting in Service Manual.	Check continuity of paper-out cable and contacts.  Check <u>PAPER ALARM CONTACT</u> adjustment.

D. 15 INCH TRACTOR FEED PRINTER TROUBLESHOOTING GUIDE

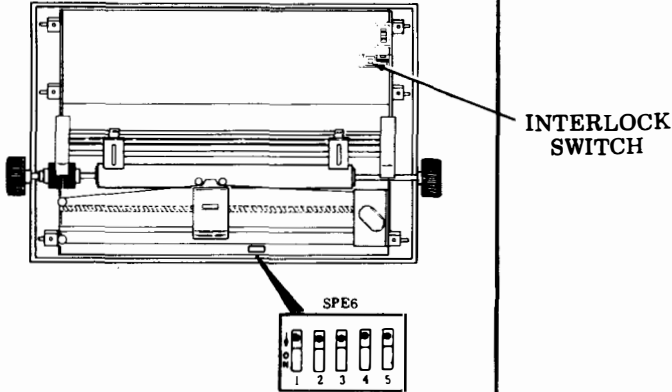
QUESTION	YES	NO
<p>1. Does test message print and paper advance properly while switch SPE6 No. 1 (Printer Test) is operated on the logic card (interlock switch closed)?</p> 	<p>Go to 2.</p>	<p>Go to 1a.</p>
<p>1a. Does carriage space and return properly?</p>	<p>Go to 1b.</p>	<p>Check for mechanical bind by moving carriage manually with power off.</p> <p>Check spacing belt tension arm spring.</p> <p>Check continuity of spacing motor and encoder.</p> <p>Check switch on the print head.</p> <p>Replace spacing motor and/or encoder or cable.</p> <p>Replace lead screw nut.</p>
<p>1b Does paper advance properly (successive lines uniformly spaced)?</p>	<p>Go to 1c.</p>	<p>Check for mechanical bind by rotating platen manually with power off.</p> <p>Check line feed motor gear backlash adjustment.</p> <p>Check printer idler gear and platen gear adjustment.</p> <p>Check tractor mechanism idler gear backlash adjustment.</p>

## D. 15 INCH TRACTOR FEED PRINTER TROUBLESHOOTING GUIDE (Contd)

QUESTION	YES	NO
1b. (Contd)		<p>Check tractor mechanism idler gear to printer platen gear adjustment.</p> <p>Check form feed tape to optical switch assembly adjustment.</p> <p>Check tractor gear to platen bushing adjustment.</p> <p>Check paper deflector shield adjustment.</p> <p>With power on (reset) check platen detenting through full rotation by turning platen knob.</p> <p>Check continuity of line feed motor.</p> <p>Replace motor or cable.</p>
1c. Are any characters printed?	Go to 1d.	<p>Check continuity of print head and cable.</p> <p>Replace logic card.</p>
1d. Are any dots missing from printed characters?	<p>Check continuity of associated print magnet.</p> <p>Check print head armature adjustment.</p> <p>Replace print head or cable.</p> <p>Replace logic card.</p>	Go to 1e.
1e. Are any dots noticeably out of line on characters with vertical segments?	Replace print head.	Go to 1f.
1f. Is proper print density obtained (good ribbon, proper multicopy paper)?	Go to 1g.	<p>Check print head to platen adjustment.</p> <p>Check that platen detent lever is in proper position for the number of ply paper being used (see How To Operate Manual for location of platen detent lever).</p>



QUESTION	YES	NO
1f. (Contd)		With power off and carriage moved manually fully right and left, check that the general direction of ribbon movement is counterclockwise as viewed from the top. If not, check carriage and left bracket ribbon for "one way" rotation.
1g. Does printed copy align properly with edge of paper (prints equally on each side of page perforation)?	Undefined problem during printer test.	Check horizontal line alignment adjustment.
2. Does alarm indicator light when a paper-out condition is sensed?	Go to 3.	Check continuity of paper-out cable and switch. Check paper-out switch adjustment. Check continuity of paper-out lamp (forward and reverse bias) and paper-out lamp cable. Replace logic card.
3. Does printer form feed properly on local form feed?	Undefined problem.	Go to 3a.
3a. Does paper feed at all when FORM key is depressed?	Go to 3b.	Check continuity of form switch and cable. Replace logic card.
3b. Does paper feed continually for about 9 seconds when FORM key is depressed?	Check form feed tape to optical switch assembly adjustment. Check continuity of form feed tape reader cable and led. Replace form feed tape reader. Replace logic card.	Go to 3c.
3c. Does paper feed only while FORM key is depressed?	Check that form feed tape is in form feed tape reader. Replace the form feed tape reader. Replace the logic card.	Undefined problem.

PART 3 — DISASSEMBLY/REASSEMBLY

	<u>CONTENTS</u>	<u>PAGE</u>
1.	GENERAL .....	3-2
2.	TOOLS REQUIRED .....	3-2
3.	12 INCH PRINTER DISASSEMBLY/REASSEMBLY.....	3-3
	PRINT HEAD WITH COVER .....	3-3
	SPACING MOTOR BELT .....	3-10
	SIGNAL BELL .....	3-10
	SPACING MOTOR WITH CABLE AND ENCODER.....	3-12
	LINE FEED MOTOR .....	3-13
	PLATEN .....	3-15
	LEAD SCREW .....	3-18
	CARRIAGE WITH POST ASSEMBLY .....	3-19
	LEAD SCREW NUT .....	3-19
	COLLAR WITH LINK .....	3-20
	PRINT HEAD SHIELD (TRACTOR FEED) AND BRIDGE ASSEMBLY.....	3-20
	PAPER TRAY.....	3-21
	PAPER GUIDES .....	3-26
	TRACTOR MECHANISM .....	3-27
4.	15 INCH PRINTER DISASSEMBLY/REASSEMBLY.....	3-30
	PRINT HEAD WITH COVER .....	3-30
	SPACING MOTOR BELT .....	3-37
	SIGNAL BELL .....	3-37
	430780 POWER SUPPLY .....	3-38
	430643 LOGIC CARD .....	3-39
	SPACING MOTOR WITH CABLE AND ENCODER.....	3-44
	LINE FEED MOTOR .....	3-46
	PAPER TENSIONER ARM.....	3-46
	TRACTOR MECHANISM .....	3-47
	PLATEN ASSEMBLY .....	3-50
	453165 PAPER TRAY .....	3-52
	LEAD SCREW .....	3-53
	CARRIAGE WITH POST ASSEMBLY .....	3-54
	LEAD SCREW NUT .....	3-55
	COLLAR WITH LINK .....	3-55
	PAPER DEFLECTOR SHIELD AND BRIDGE ASSEMBLY .....	3-56
	TOP OF FORM TAPE READER .....	3-57

## 1. GENERAL

- 1.01 This part provides disassembly/reassembly procedures for the 12 inch friction feed, sprocket (pin) feed and tractor feed printer mechanisms and the 15 inch tractor feed printer mechanism.
- 1.02 The printer mechanism is not considered a field replaceable item. Any trouble can be corrected by adjustments or by replacement with maintenance spares.
- 1.03 Procedures are provided to remove individual assemblies and parts and are intended to directly access any assembly or part, insofar as possible, without total disassembly of the unit.
- 1.04 When removing a subassembly or part from the printer, follow the removal procedure and note the sequence of removal to enable proper reassembly. For reassembly, reverse the procedure except where different instructions are given. Perform any adjustments indicated using Part 4.
- 1.05 Disassembly of printer parts except the print head, platen, paper deflector shield, bridge assembly and tractor mechanism will require the removal of the set housing and rear frame. Refer to the appropriate service manual for set housing and rear frame removal and replacement procedures.
- 1.06 Disassembly of the printer motors will require the removal of the logic card.
- 1.07 Disassembly of the printer lead screw, carriage with post assembly, lead screw nut(s), and collar with link will require the removal of the keyboard, if present.
- 1.08 After replacing printer parts, refer to the lubrication procedures in Part 6 and lubricate any parts requiring lubrication.
- 1.09 When ordering replaceable parts or components, unless otherwise specified, prefix each part number with the letters "TP" (ie, TP4300047).
- 1.10 Reference in the procedures to left and right, up or down, and top or bottom, etc, refer to the printer in its normal operating position as viewed by the operator.

## 2. TOOLS REQUIRED

- 2.01 The following tools may be required when performing the printer disassembly/reassembly procedures. Most of these items should normally be present in standard maintenance tool kits.

<u>Part No.</u>	<u>Description</u>
75765	Hook, Pull Spring
95368	Screwdriver, 1/8 Inch, 2 Inch Blade
100704	Screwdriver With Clip, 10 Inch Blade
100982	Screwdriver With Clip, 1/4 Inch, 6 Inch Blade
108285	Pliers, Long-Nose
110271	Wrench, Hex Key
124682	Wrench, Hex Key
125752	Wrench, 3/16 Inch Socket
129534	Wrench, Open End, 3/16 Inch and 1/4 Inch
142554	Hook, Pull Spring
142555	Hook, Push Spring
151392	Tweezers
152835	Wrench, Open End, 5/16 Inch and 3/8 Inch
348097	Nut Driver, 1/4 Inch
348098	Nut Driver, 5/16 Inch
407326	Extractor, I.C.

### 3. 12 INCH PRINTER DISASSEMBLY/REASSEMBLY

#### PRINT HEAD WITH COVER

3.01 To remove the print head with cover:

*Caution: When handling loose print heads, care must be taken to prevent print head cable connector pins from being bent.*

- ⑧ Grasp print head and pull forward. Lift front of print head to disengage locking channels.

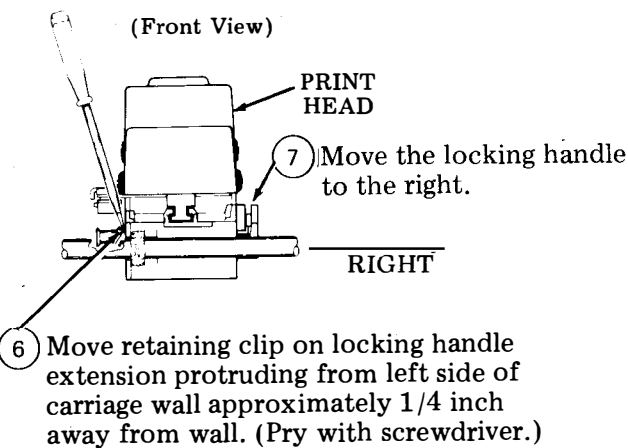

- ⑨ Disengage print head from roll pin on end of link. Remove print head.

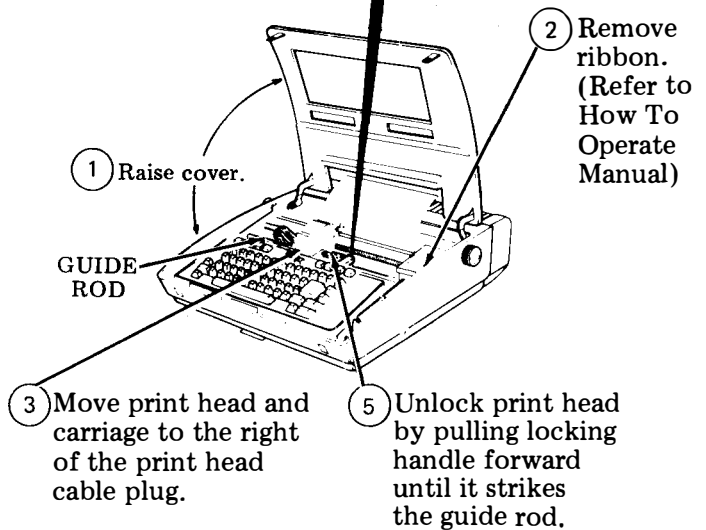
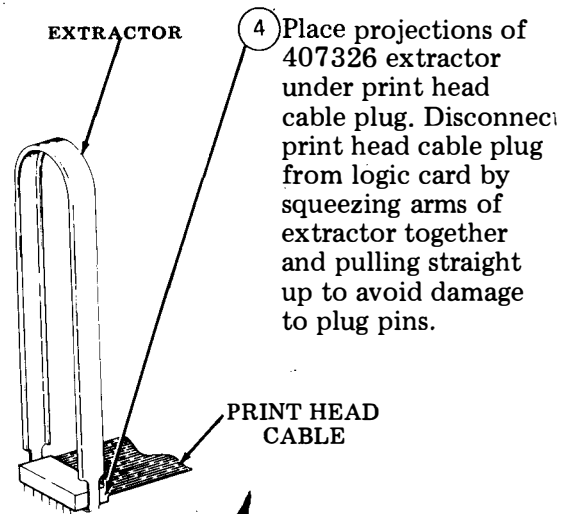
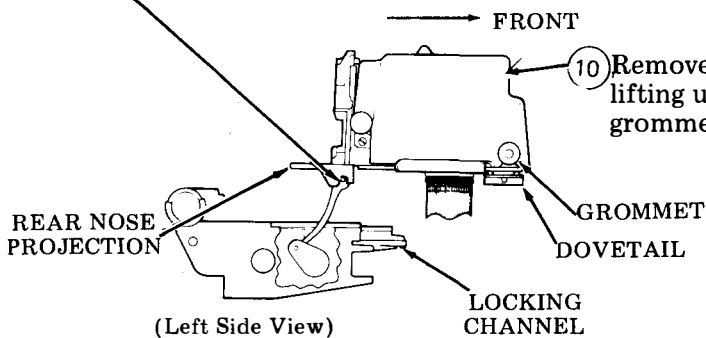

3. 12 INCH PRINTER DISASSEMBLY/REASSEMBLY (Contd)

PRINT HEAD WITH COVER (Contd)

3.02 To replace the print head with cover:

*Caution: When handling loose print heads, care must be taken to prevent print head cable connector pins from being bent.*

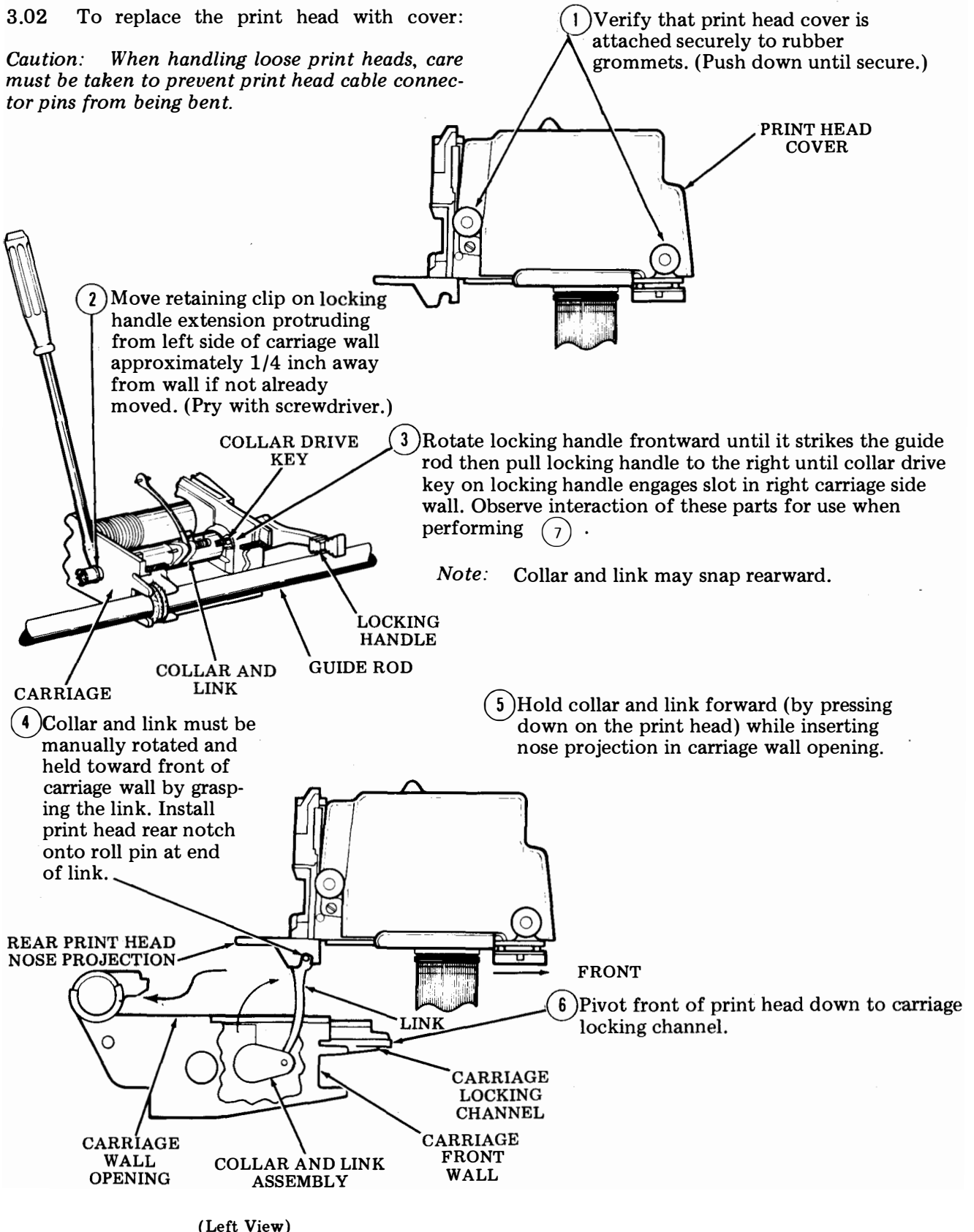

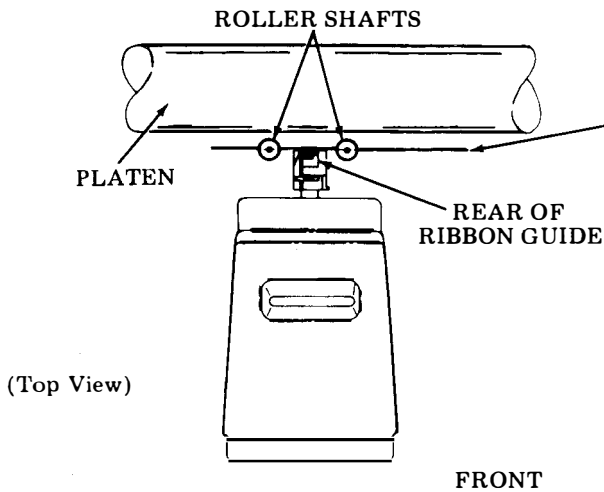

(Top View)

FRONT

7 Slowly push print head rearward and further into the carriage locking channel until the rear of the ribbon guide is even with center of roller shafts. Apply continuous leftward pressure to locking handle at its pivot shaft, while slowly pulling print head forward until collar drive key on handle engages (snaps) into slot in collar.

Note: Parts referred to were visible in 3

9 Position and hold print head and carriage assembly to right side of printer and use a 5/16 inch socket wrench to push clip against carriage wall.

(Front View)

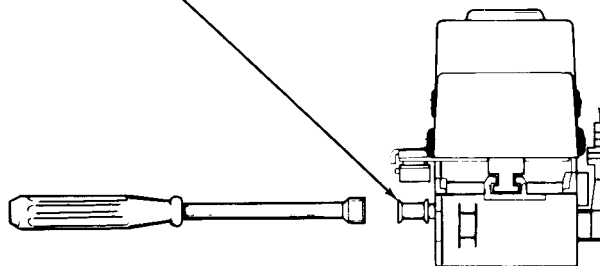

8 Move the handle all the way to the rear, locking the print head in close proximity to the platen by the additional force necessary to detent the handle. If handle does not move to rear, the drive key did not properly engage the collar slot 7.

Note: Check to make sure there is some clearance between print head and platen before detenting handle. Check PRINT HEAD TO PLATEN adjustment.

10 Check that no connector pins are bent and carefully connect the print head cable plug to the logic card. Make sure cable does not touch left side frame when the carriage moves fully left.

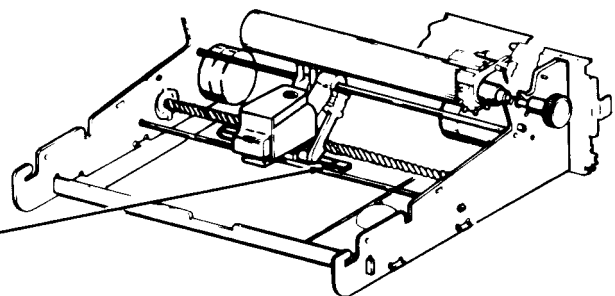

11 Install ribbon. (Refer to How To Operate Manual.)

3. 12 INCH PRINTER DISASSEMBLY/REASSEMBLY (Contd)

PRINT HEAD WITH COVER (Contd)

3.03 To remove the cover:

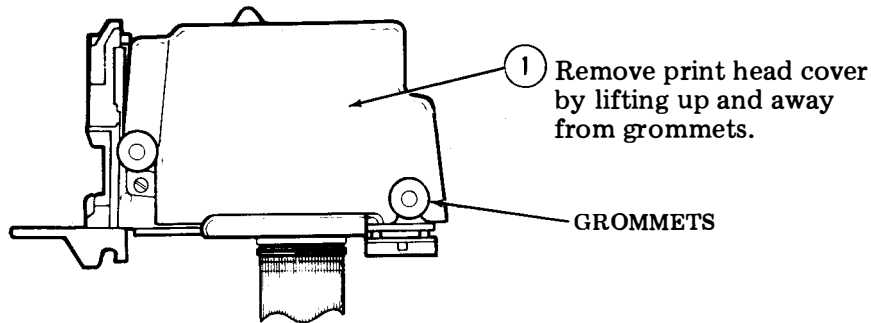

3.04 To remove the cable:

1 Remove print head cover (perform 3.03, 1).

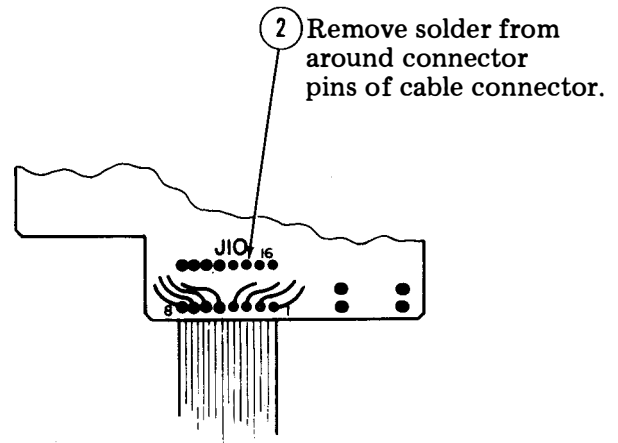

*Warning: Use a grounded, low-wattage soldering iron (avoid prolonged contact with pins) along with a desoldering tool to prevent damage to card circuits and components.*

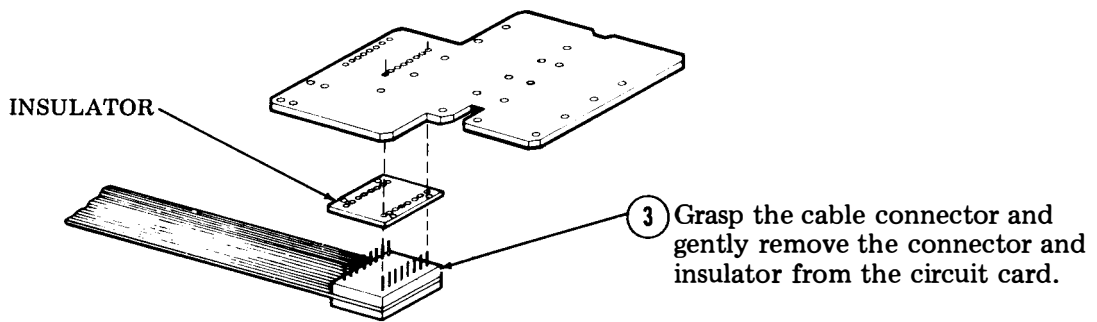

*Note: In reassembly, make sure insulator is positioned between cable connector and circuit card as shown.*

3.05 To remove the ribbon guide:

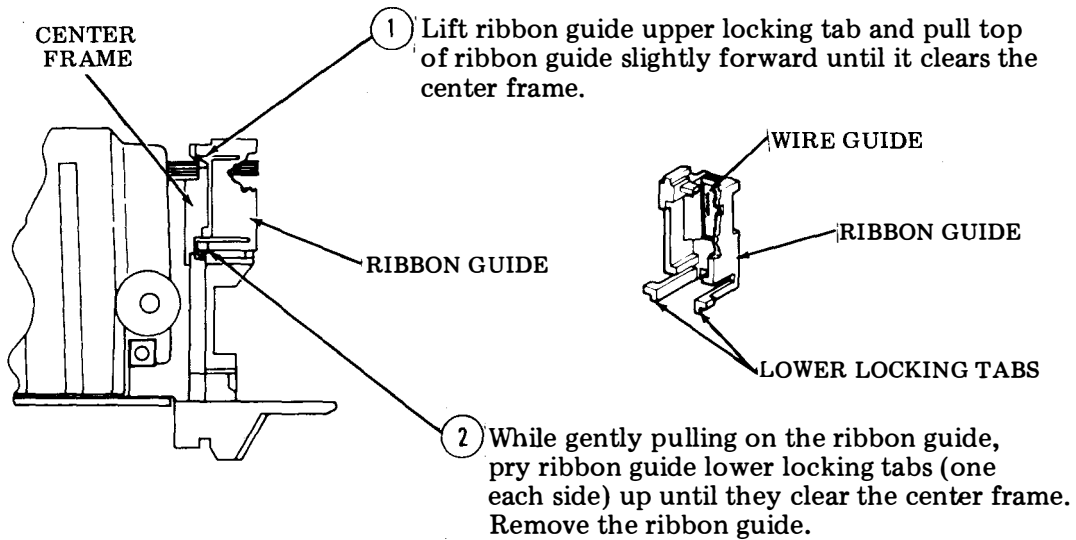

*Note:* Visually inspect the wire guide for cracks or damage whenever the ribbon guide is removed, and replace if damaged.

3.06 To replace the ribbon guide:

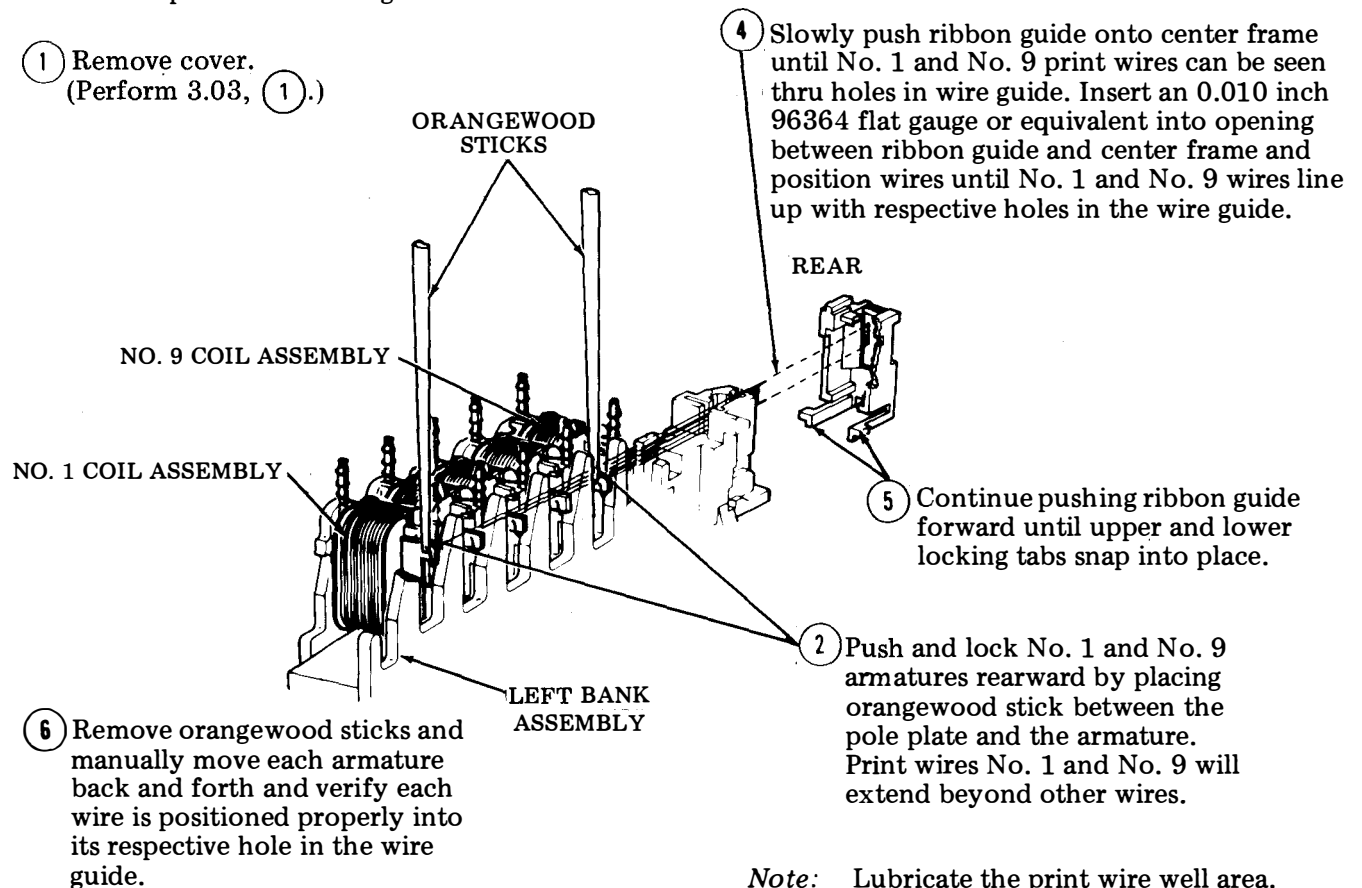

*Note:* Lubricate the print wire well area.



3. 12 INCH PRINTER DISASSEMBLY/REASSEMBLY (Contd)

PRINT HEAD WITH COVER (Contd)

3.07 To remove the wire guide:

- ① Remove the ribbon guide (perform 3.05, ① and ②).

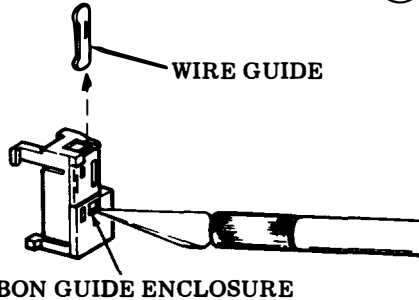

- ② Insert pointed flat blade (hobby knife) under wire guide and gently pry up until bottom of wire guide clears ribbon guide enclosure. Grasp wire guide and pull straight up to remove.

*Note:* In reassembly, insert wire guide into ribbon guide as shown above and push down until bottom of wire guide is against bottom of ribbon guide enclosure.

3.08 To remove the sleeve:

- ① Remove the cover (perform 3.03, ①).

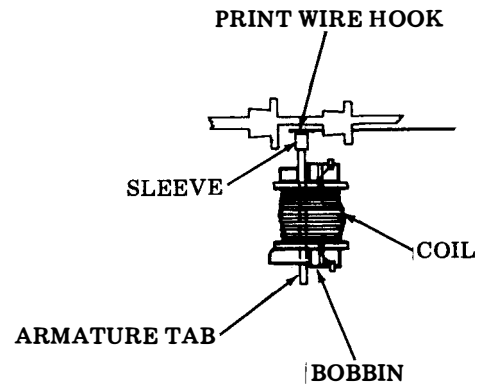
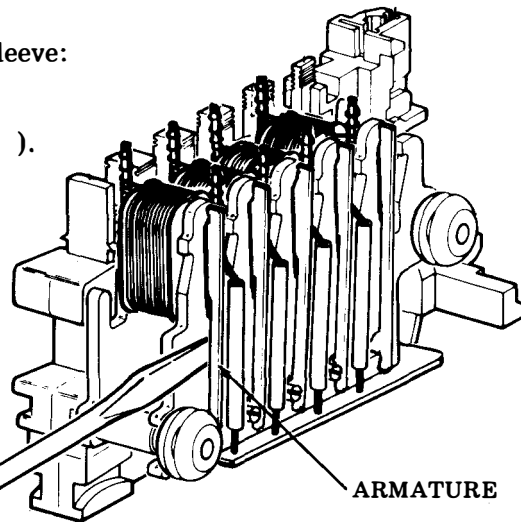

- ② Pry armature gently outward (away from print wires) until sleeve slides free of print wire hook and armature tab clears bobbin.

- ③ Grasp armature and push toward ribbon guide (magnet will pull armature away from ribbon guide) until armature touches bobbin. Pull armature and sleeve gently outward.

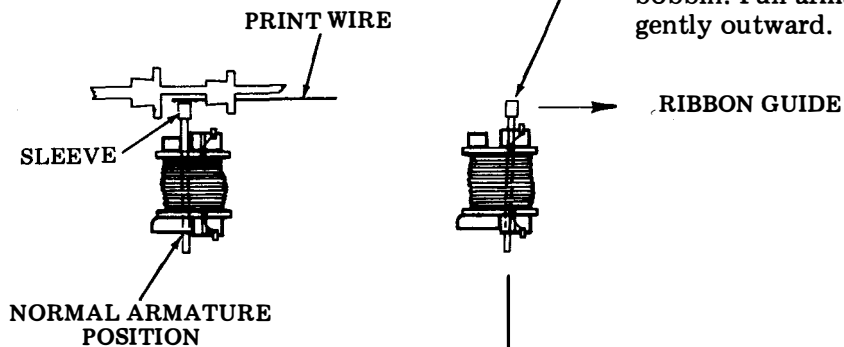

- ④ Remove sleeve from armature extension.

*Note:* In reassembly, make sure sleeve is positioned over grooves in armature extension and flush with extension edge. Lubricate any armatures removed and replaced.

3.09 To remove the coil assembly:

- ① Remove print head cover (perform 3.03, ①).

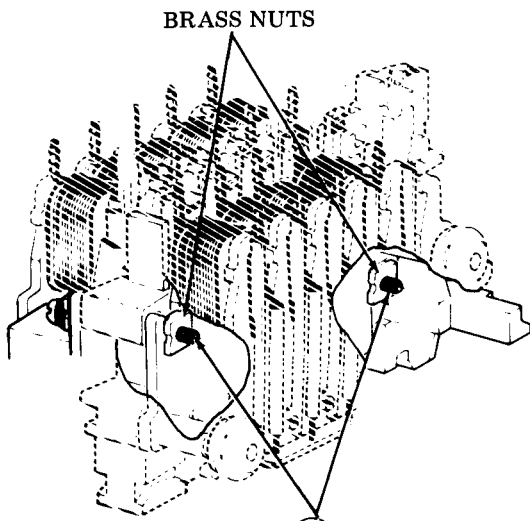

- ② Loosen two pole plate screws.

- ③ Remove armature (perform 3.08, ② and ③).

*Note:* In reassembly, note positioning of brass nuts and verify correct position as shown before tightening screws. Lubricate any armatures removed and replaced.

- ⑤ Pry locking tab on bobbin until it clears the pole plate.

- ⑥ Pull the coil assembly straight up and remove. Use a spring hook.

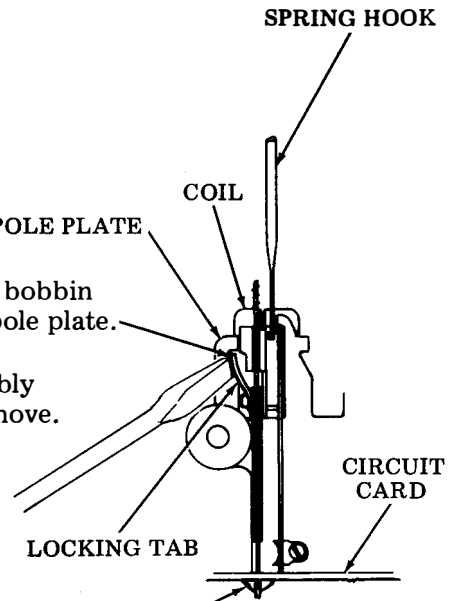

- ④ Remove solder from around coil assembly terminals.

*Warning:* Use a low wattage soldering iron (avoid prolonged contact with terminals) along with a desoldering tool to prevent damage to circuitry.

3. 12 INCH PRINTER DISASSEMBLY/REASSEMBLY (Contd)

SPACING MOTOR BELT

3.10 To remove the spacing motor belt:

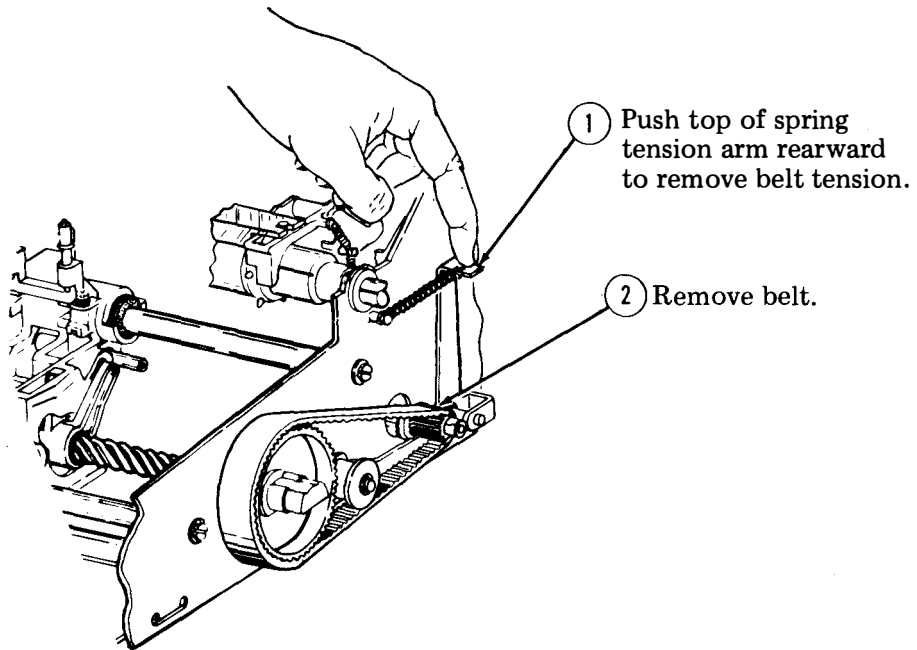

SIGNAL BELL

3.11 To remove the signal bell:

(a) Early Design

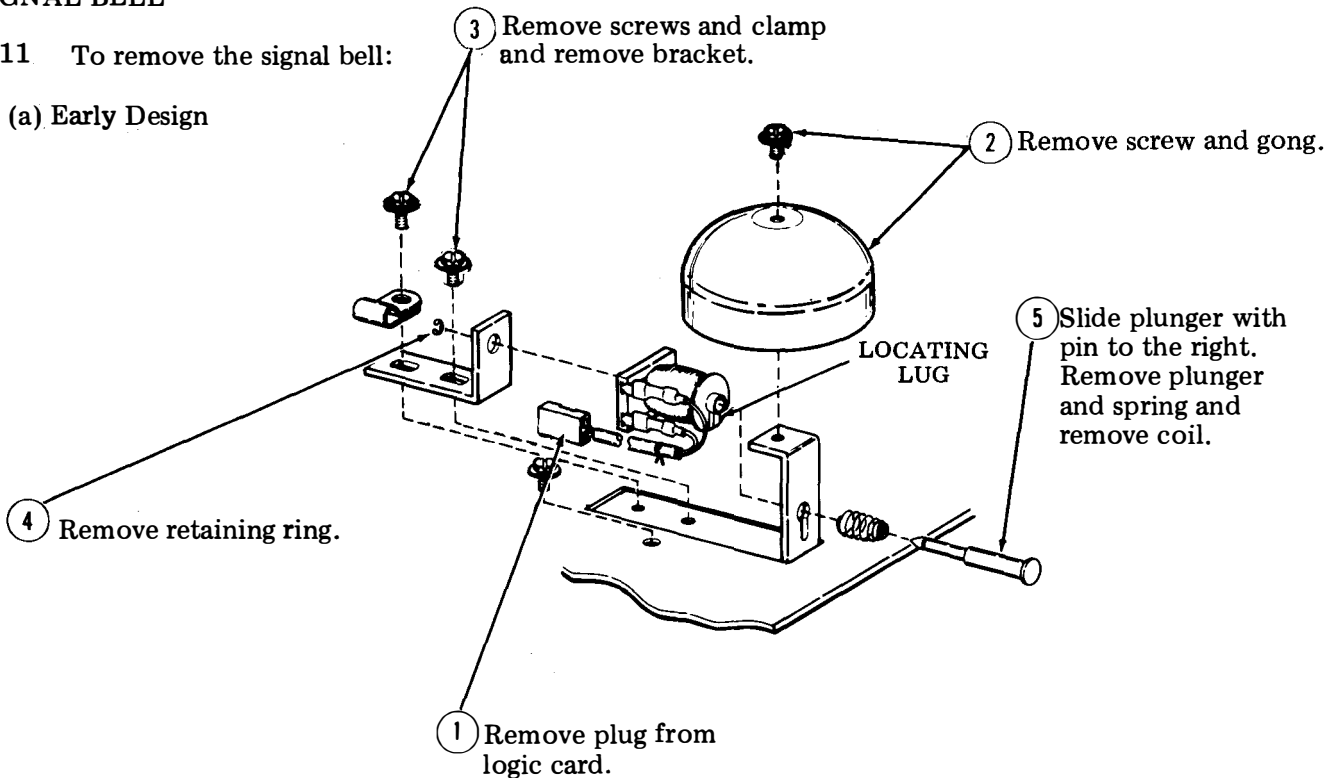

(b) Late Design

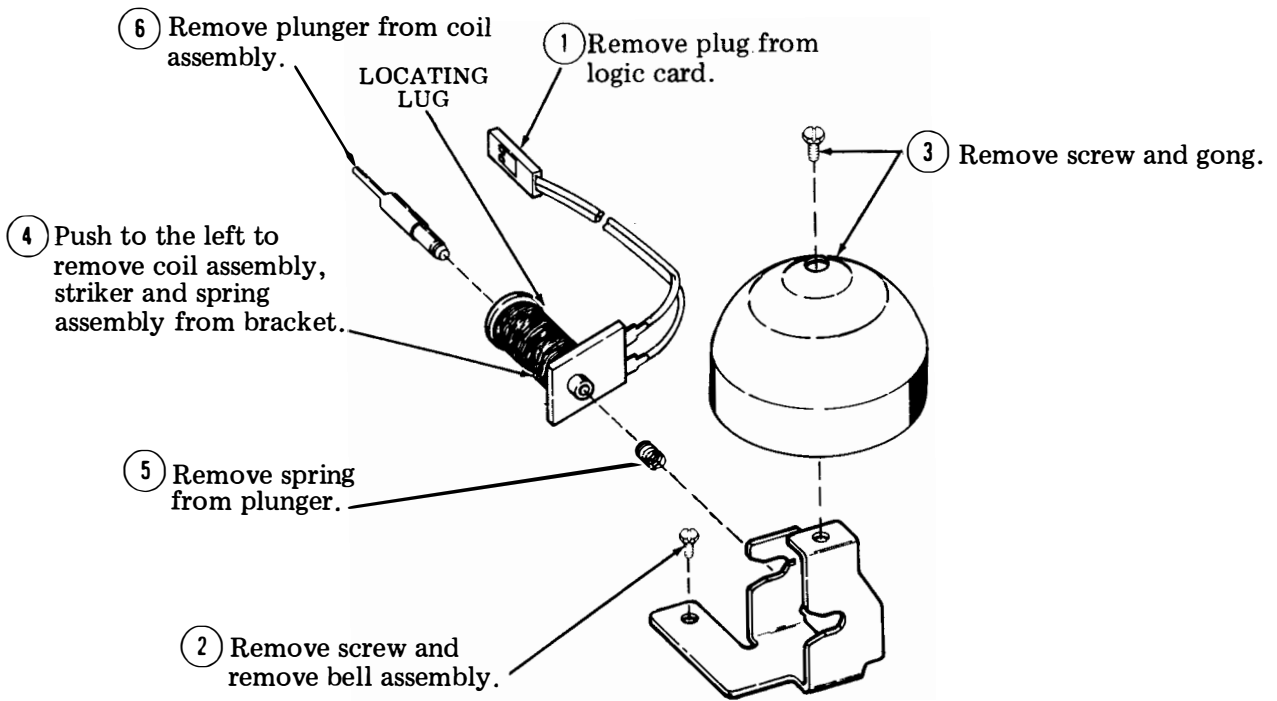

3. 12 INCH PRINTER DISASSEMBLY/REASSEMBLY (Contd)SPACING MOTOR WITH CABLE AND ENCODER

3.12 To remove the spacing motor:

- ① Remove the logic card (if present). Refer to the appropriate service manual.

(Right Side View)

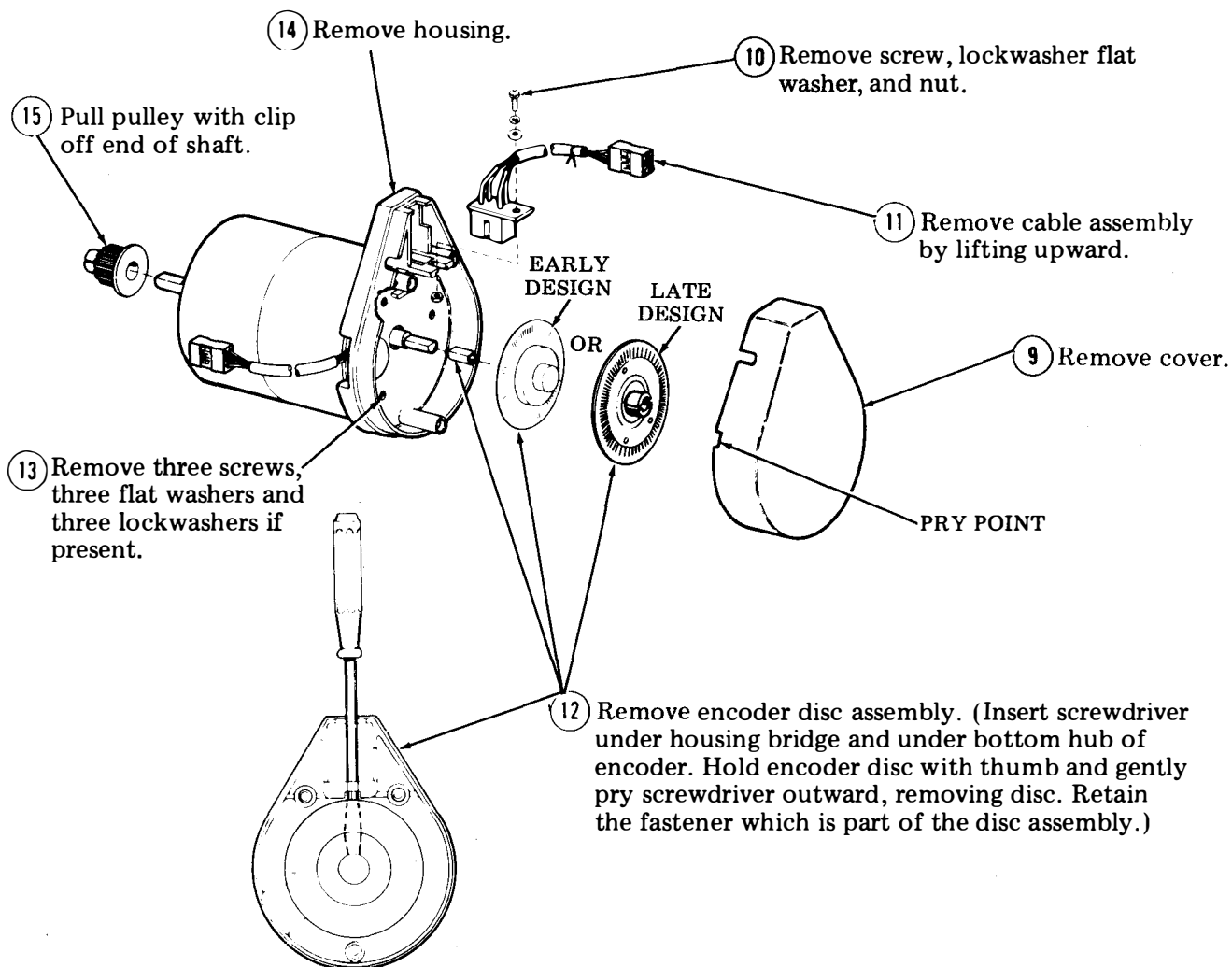
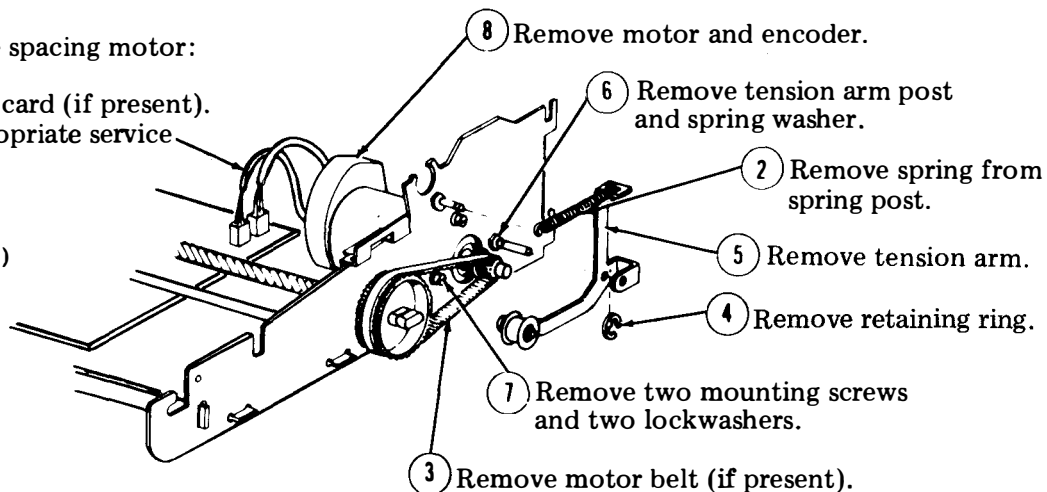

*Note:* In reassembly, make sure disc does not rub on encoder assembly.

*Warning:* Do not pull on metal disc edges as this will deform encoder disc causing it to rub against the encoder.

**LINE FEED MOTOR**

3.13 To remove the line feed motor:

(a) Without Tension Arm

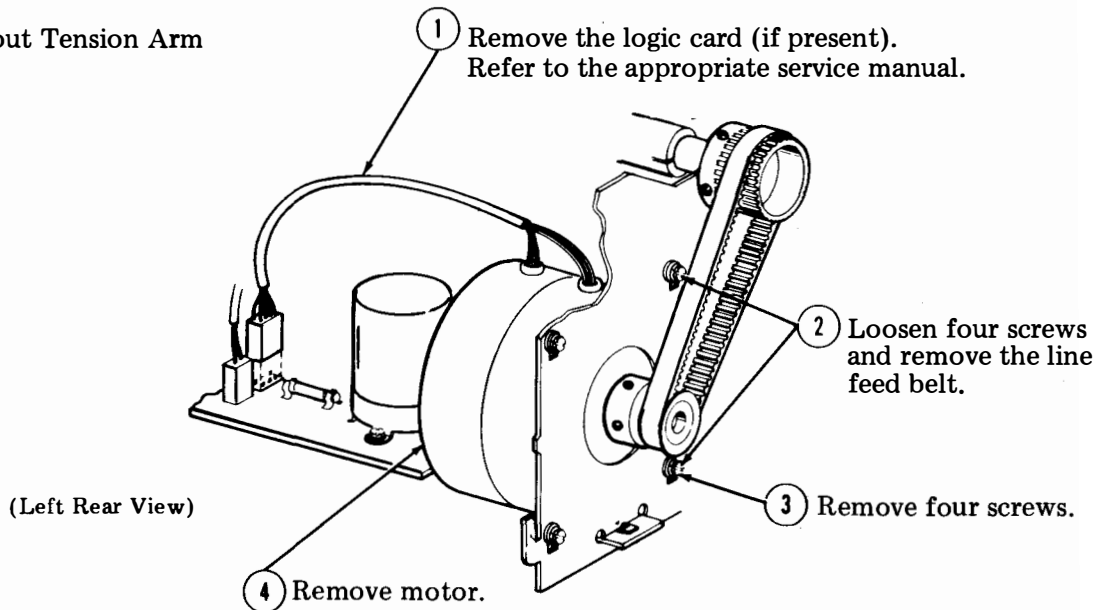

Note: In reassembly, perform LINE FEED BELT TENSION adjustment.

(b) With Tension Arm

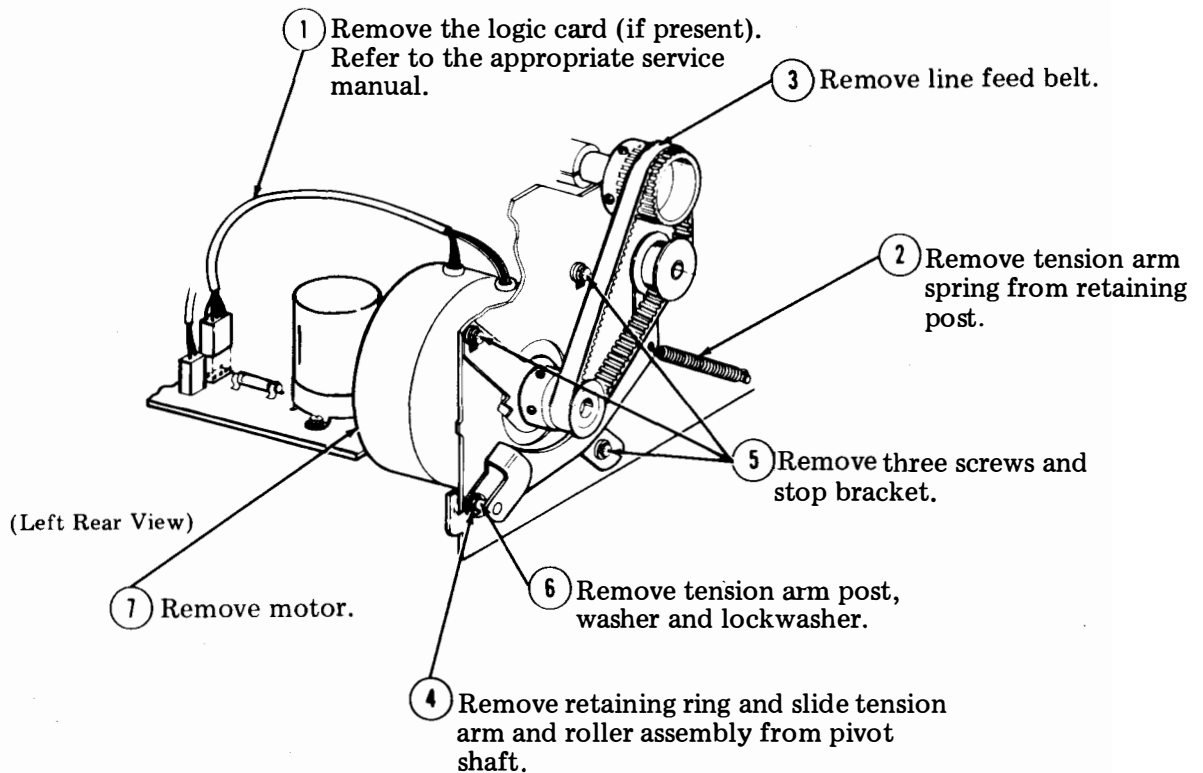

Note: In reassembly, perform STOP BRACKET adjustment.

3. 12 INCH PRINTER DISASSEMBLY/REASSEMBLY (Contd)

LINE FEED MOTOR (Contd)

(c) With Floating Motor

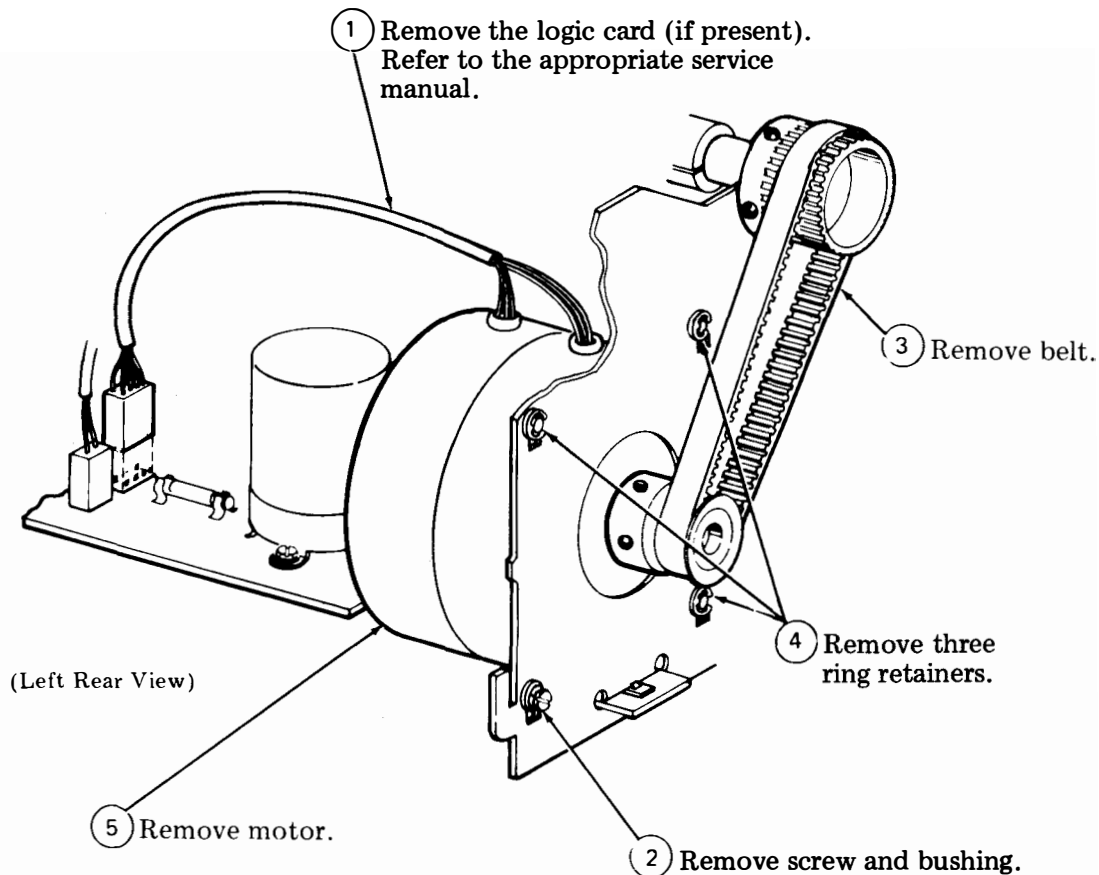

(d) With Tractor Mechanism

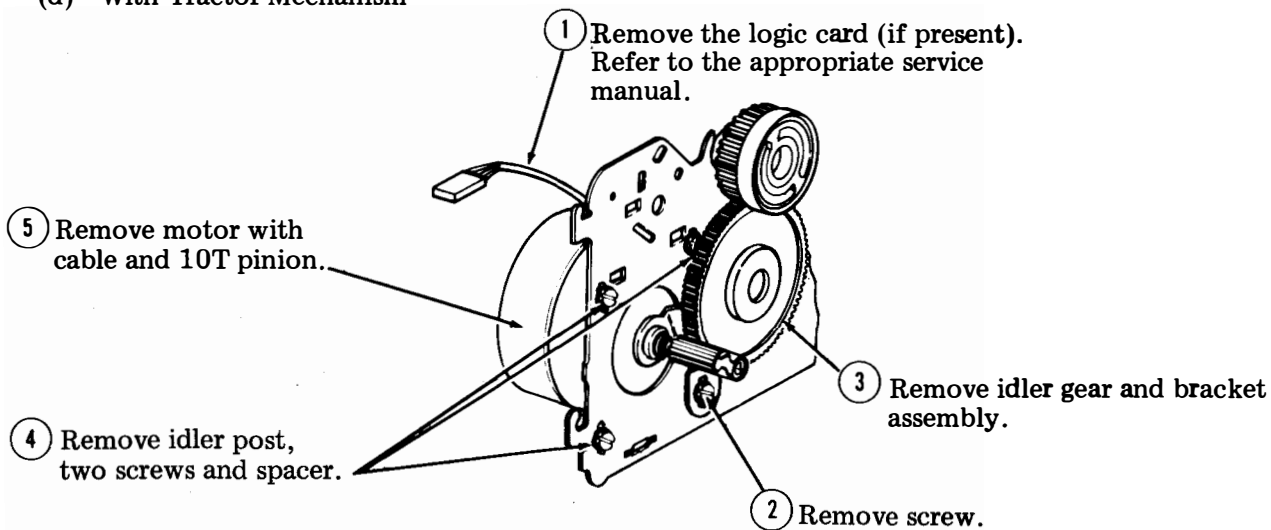

**Note:** In reassembly, perform the IDLER GEAR and PLATEN GEAR adjustments and the LINE FEED MOTOR GEAR - BACKLASH adjustment.

PLATEN

3.14 To remove the platen:

(a) Motor without tension arm or floating motor.

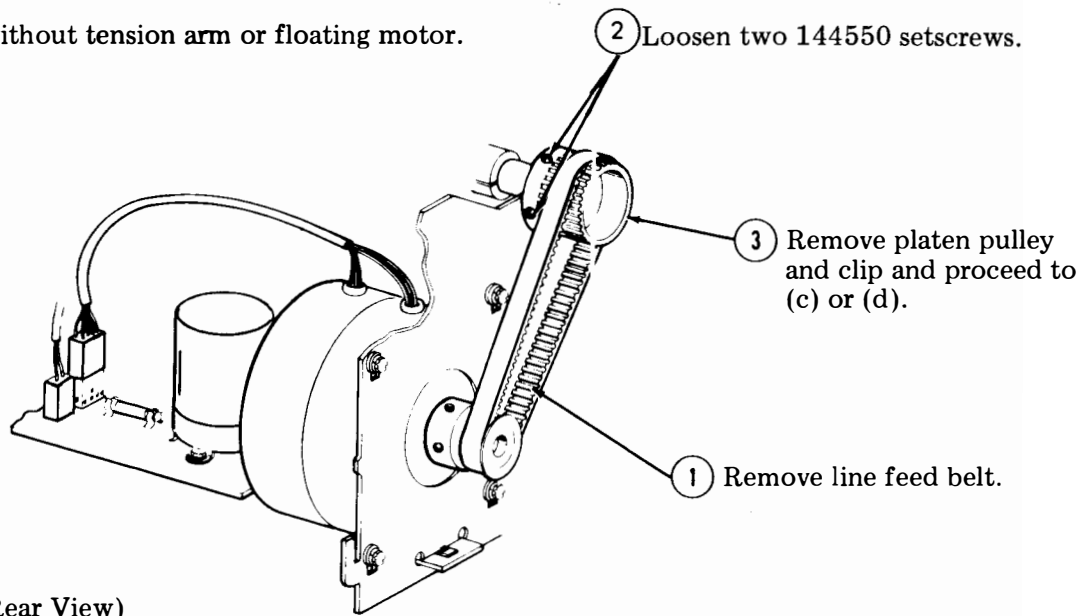

*Note:* In reassembly, position the setscrews away from the slot in the platen clip.

(b) Motor with tension arm.

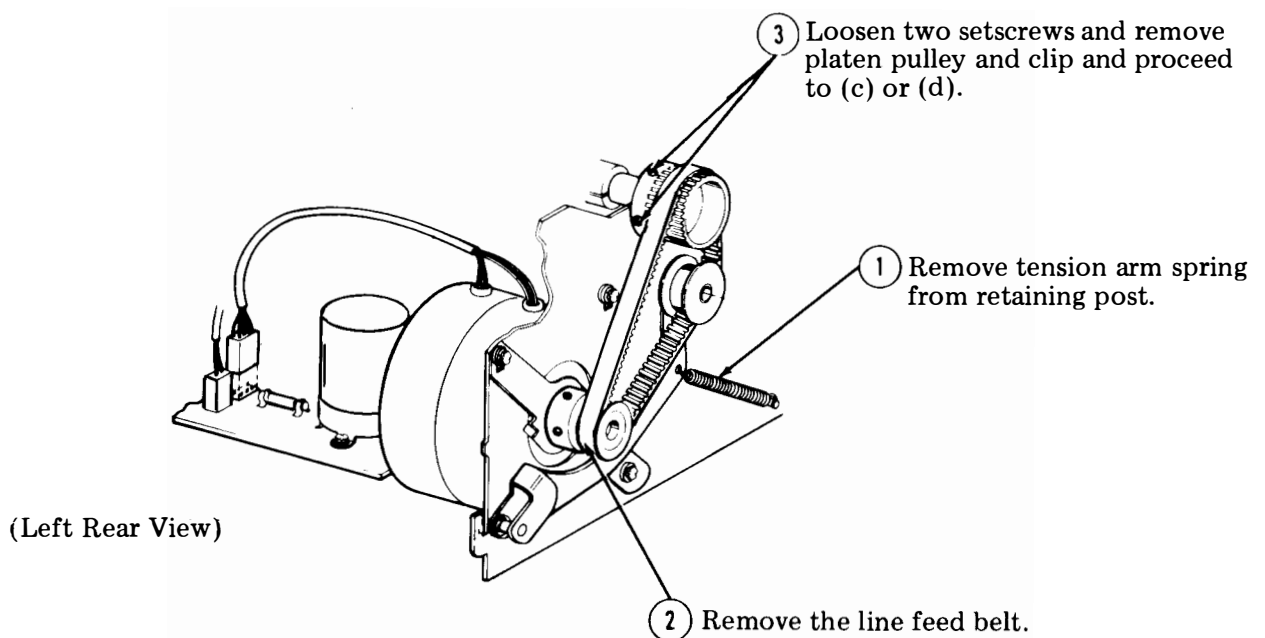



3. 12 INCH PRINTER DISASSEMBLY/REASSEMBLY (Contd)

PLATEN (Contd)

(c) Early Design Platen (Sprocket and Friction Feed)

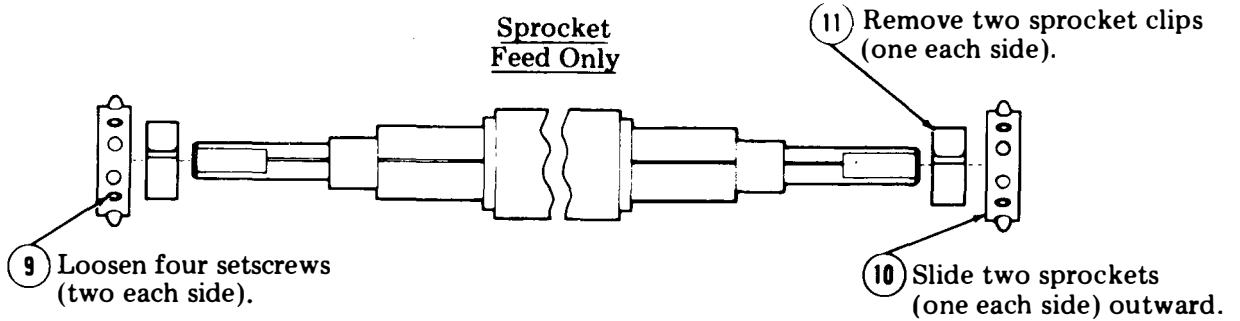
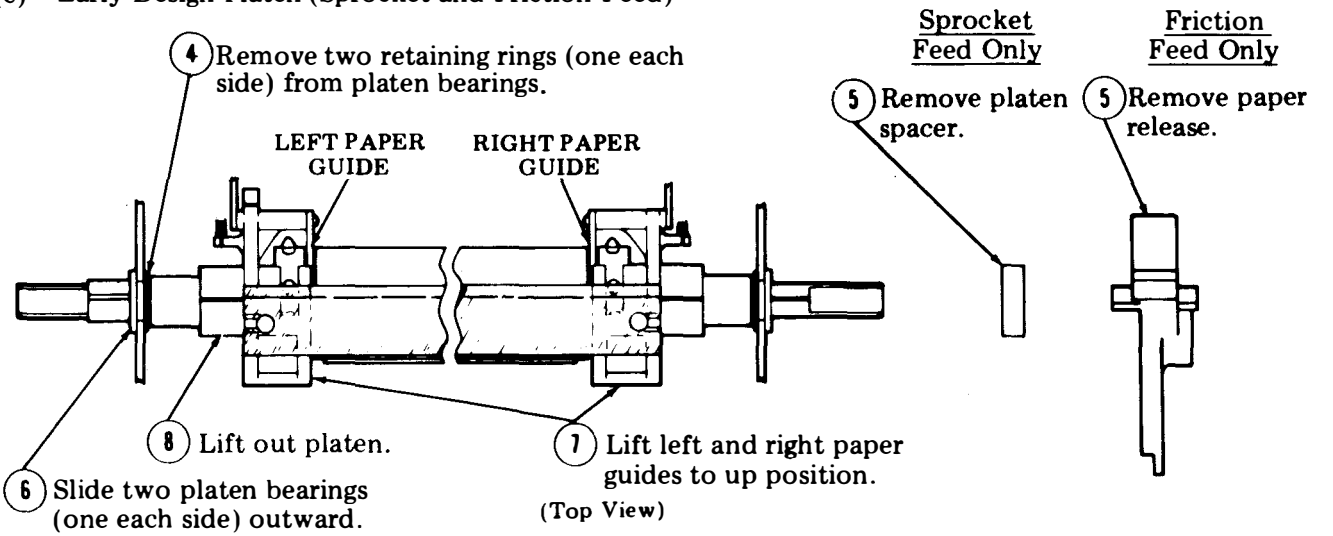

*Note:* In reassembly, position the setscrews away from the slot in the sprocket clip.

Perform the LEFT and RIGHT SPROCKET adjustments and PRINTED LINE POSITION and PLATEN ENDPLAY adjustments.

(d) Late Design Platen (Sprocket and Friction Feed)

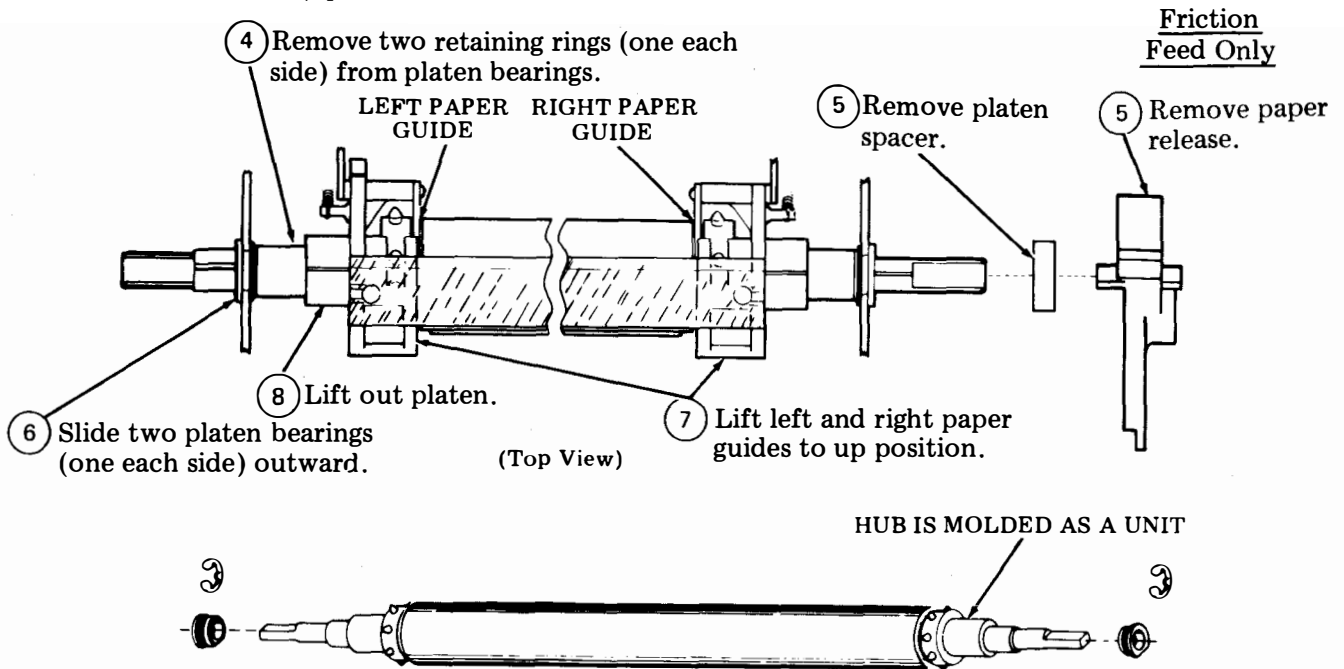

Note: In reassembly, perform the PLATEN ENDPLAY adjustments.

(e) Tractor Feed Platen

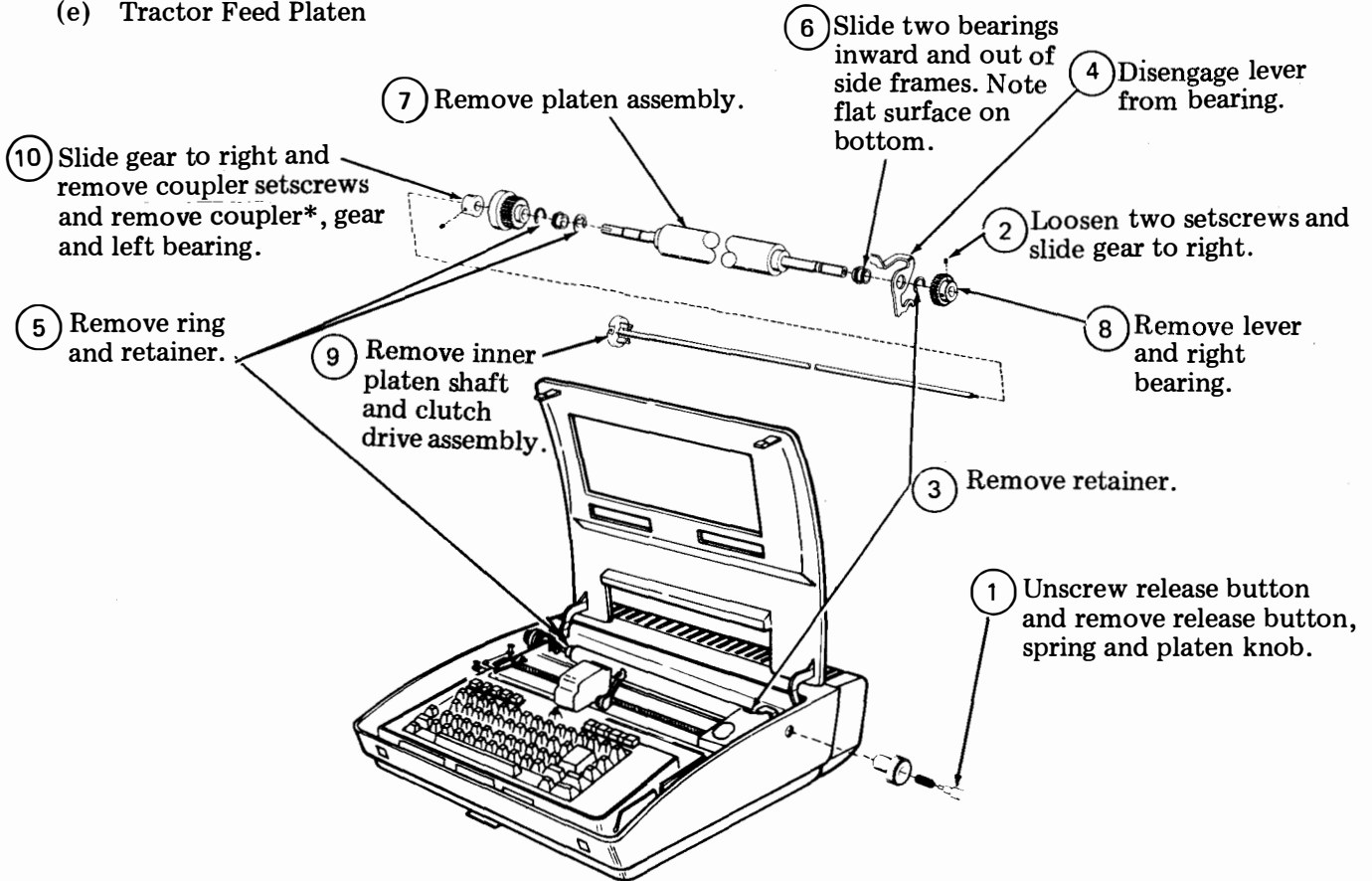

\*In reassembly, clutch drive must be engaged with coupler when coupler setscrews are tightened.

Note: In reassembly, perform PLATEN ENDPLAY adjustment.

3. 12 INCH PRINTER DISASSEMBLY/REASSEMBLY (Contd)

LEAD SCREW

3.15 To remove the lead screw:

① Remove keyboard if present. Refer to the appropriate service manual.

④ Push in right bearing housing to clear right frame. Rotate 90 degrees and spring will force bearing and housing away from side frame. Remove housing with bearing, inner bearing or shim, and spring.

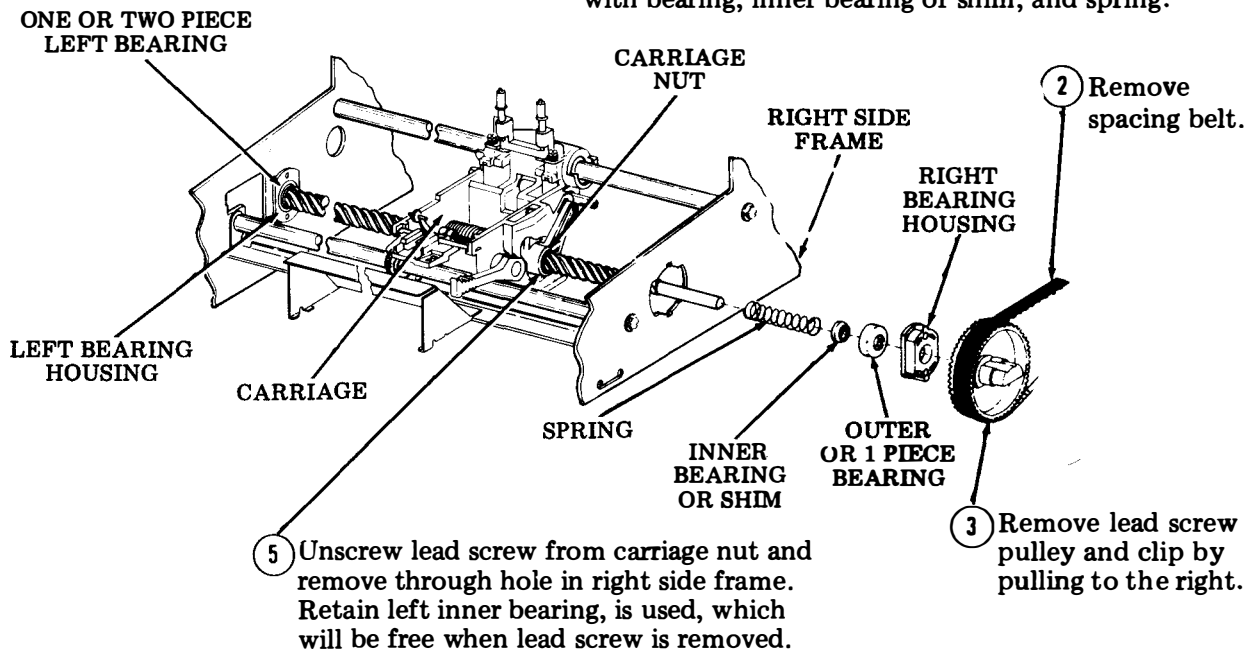

CARRIAGE WITH POST ASSEMBLY

3.16 To remove the carriage with post assembly:

*Note:* The upper guide rod must be nickel plated. The lower guide rod may be nickel plated or black oxide.

- ① Remove keyboard, if present. Refer to the appropriate service manual.
- ② Remove print head and lead screw (perform 3.01 and 3.15).
- ③ Move carriage to left margin. Remove carriage cable from logic card.
- ④ Remove screw and washer from each guide rod.

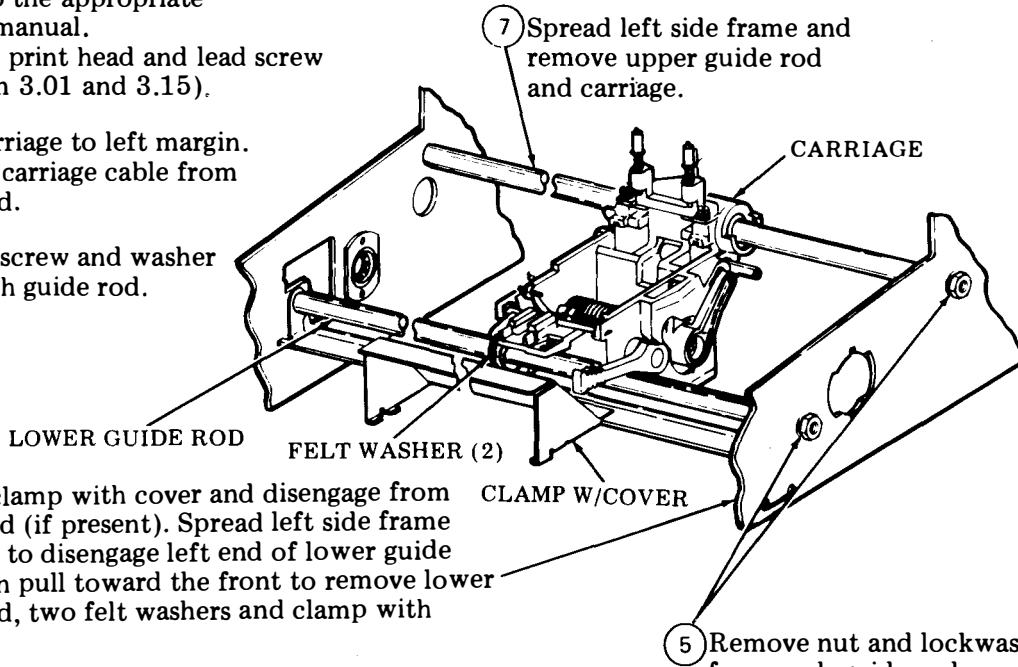

- ⑥ Spread clamp with cover and disengage from logic card (if present). Spread left side frame outward to disengage left end of lower guide rod, then pull toward the front to remove lower guide rod, two felt washers and clamp with cover.

- ⑤ Remove nut and lockwasher from each guide rod.

3.17 To remove the lead screw nut:

- ① Remove keyboard, if present. Refer to the appropriate service manual.
- ② Remove print head and lead screw (perform 3.01 and 3.15).
- ③ Tilt lead screw nut handle outward to clear retaining notch in carriage. Rotate counterclockwise (CCW) until tabs on nut align with opening in carriage. Spring will force nut away from carriage.
- ④ Remove springs and nuts.

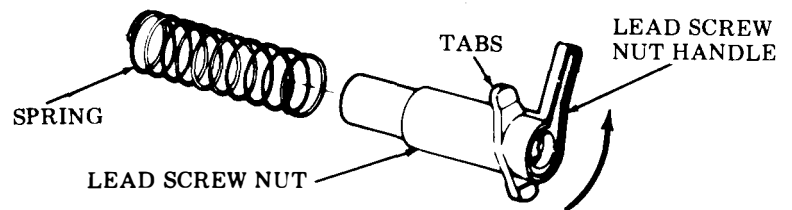

ROTATE CCW  
Early Design Nut Arrangement

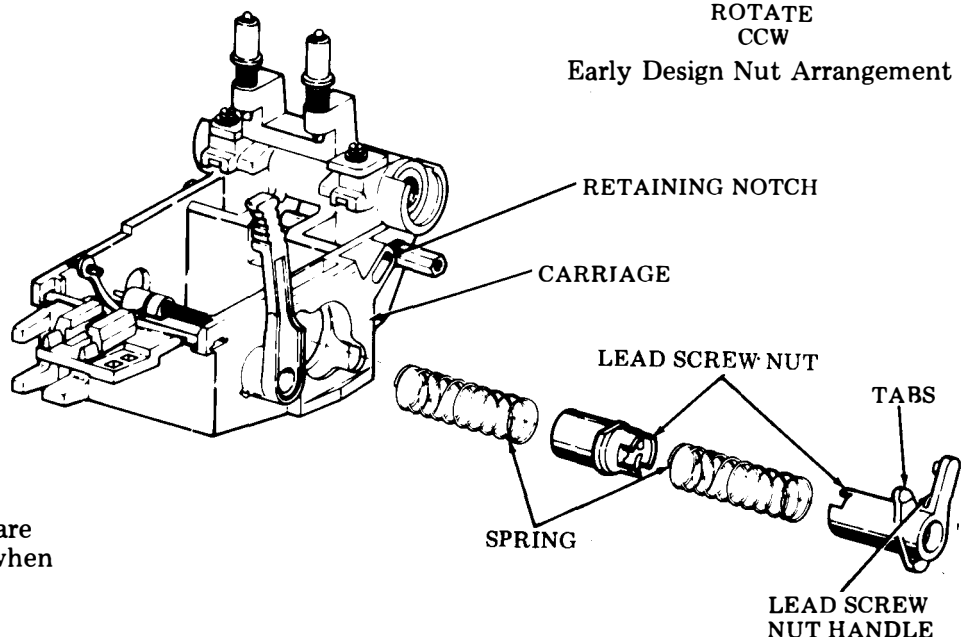

Late Design Nut Arrangement

*Note:* The lead screw nuts are keyed and must be engaged when properly installed.

3. 12 INCH PRINTER DISASSEMBLY/REASSEMBLY (Contd)

COLLAR WITH LINK

3.18 To remove the collar with link:

① Remove keyboard, if present. Refer to the appropriate service manual.

② Remove print head and carriage (perform 3.01 and 3.16).

③ Remove compression ring.

⑤ Remove collar with link.

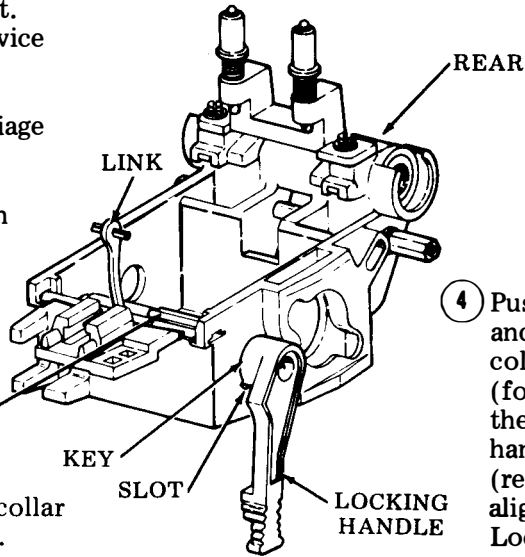

④ Push locking handle to the left and rotate locking handle and collar fully counterclockwise (forward). Pull the handle to the right while slowly rotating handle and collar clockwise (rearward) until key on handle aligns with slot in carriage. Locking handle will pop out.

PRINT HEAD SHIELD (TRACTOR FEED) AND BRIDGE ASSEMBLY

3.19 To remove the print head shield (tractor feed) and bridge assembly:

① Center the print head and pull the print head locking handle toward the keyboard as far as it will go.

② Remove the ribbon if present.

*Note 1:* To prevent the special nuts, which are keyed, from falling out of their slots, insert a piece of foam rubber under the nuts such that it holds them into position. Remove foam rubber after reassembly.

*Note 2:* In reassembly, push the print head shield (tractor feed) fully against the mounting screws (toward keyboard) before tightening mounting screws.

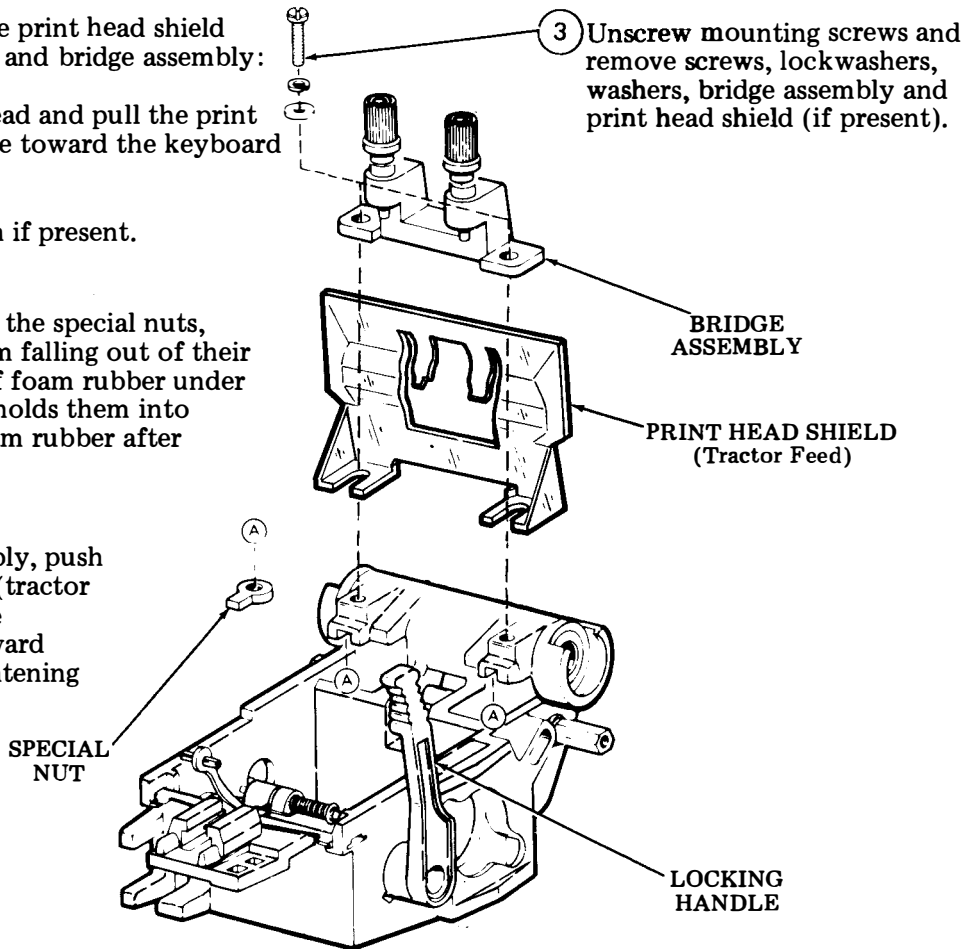

PAPER TRAY

3.20 To remove the paper tray:

(a) Sprocket Feed, Early Arrangement

*Note 1:* Parts on left and right sides are similar.

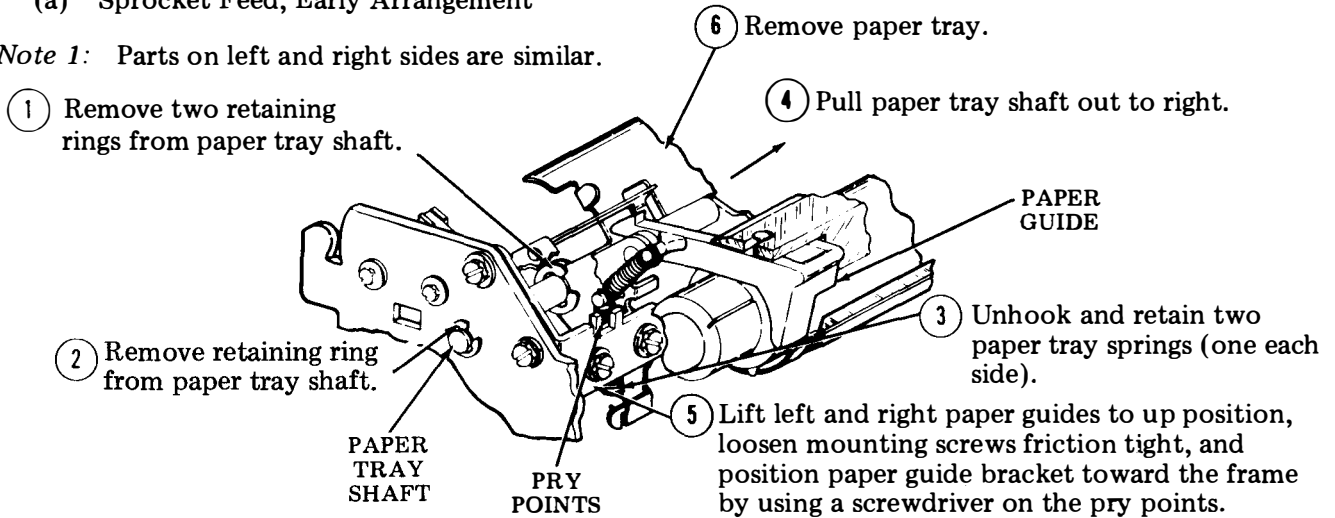

*Note 2:* In reassembly, LEFT and RIGHT PAPER GUIDE adjustments must be made.

3. 12 INCH PRINTER DISASSEMBLY/REASSEMBLY (Contd)

PAPER TRAY (Contd)

(b) Sprocket Feed (Intermediate Design) and Friction Feed (Early Design)

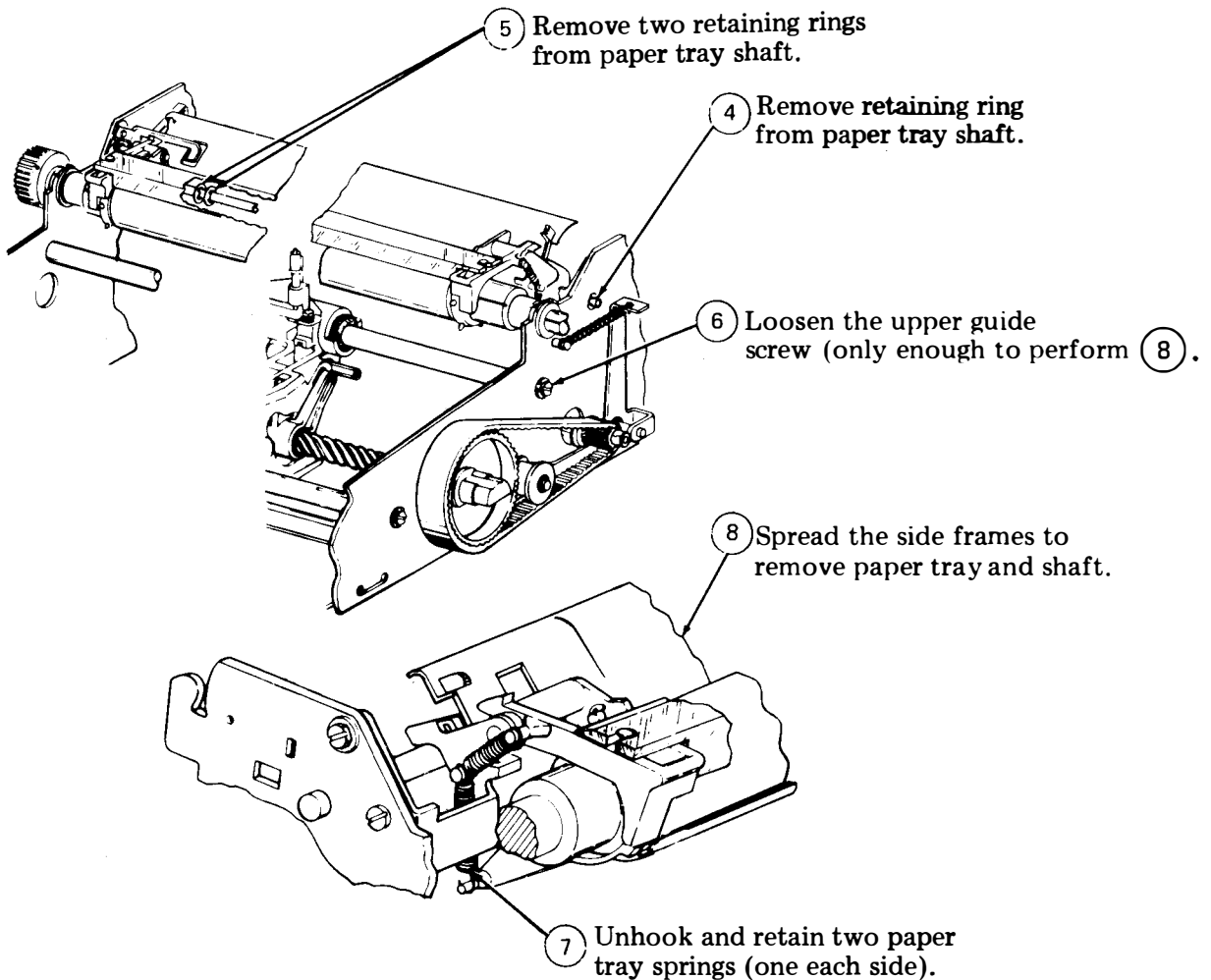
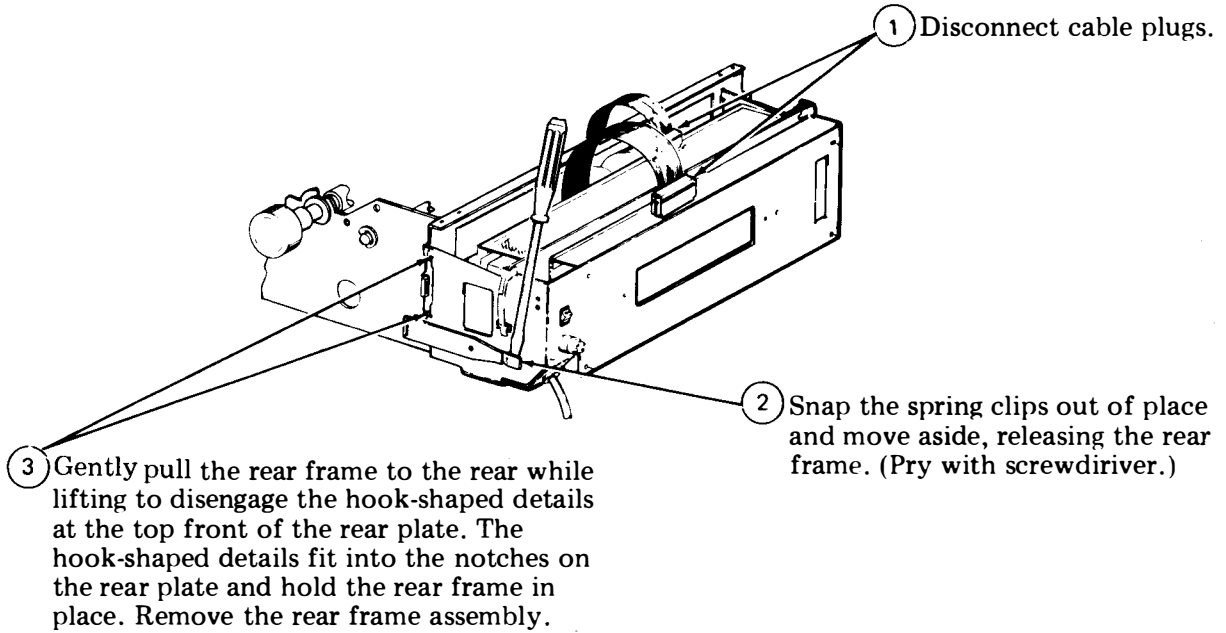

(c) Sprocket Feed, Late Design

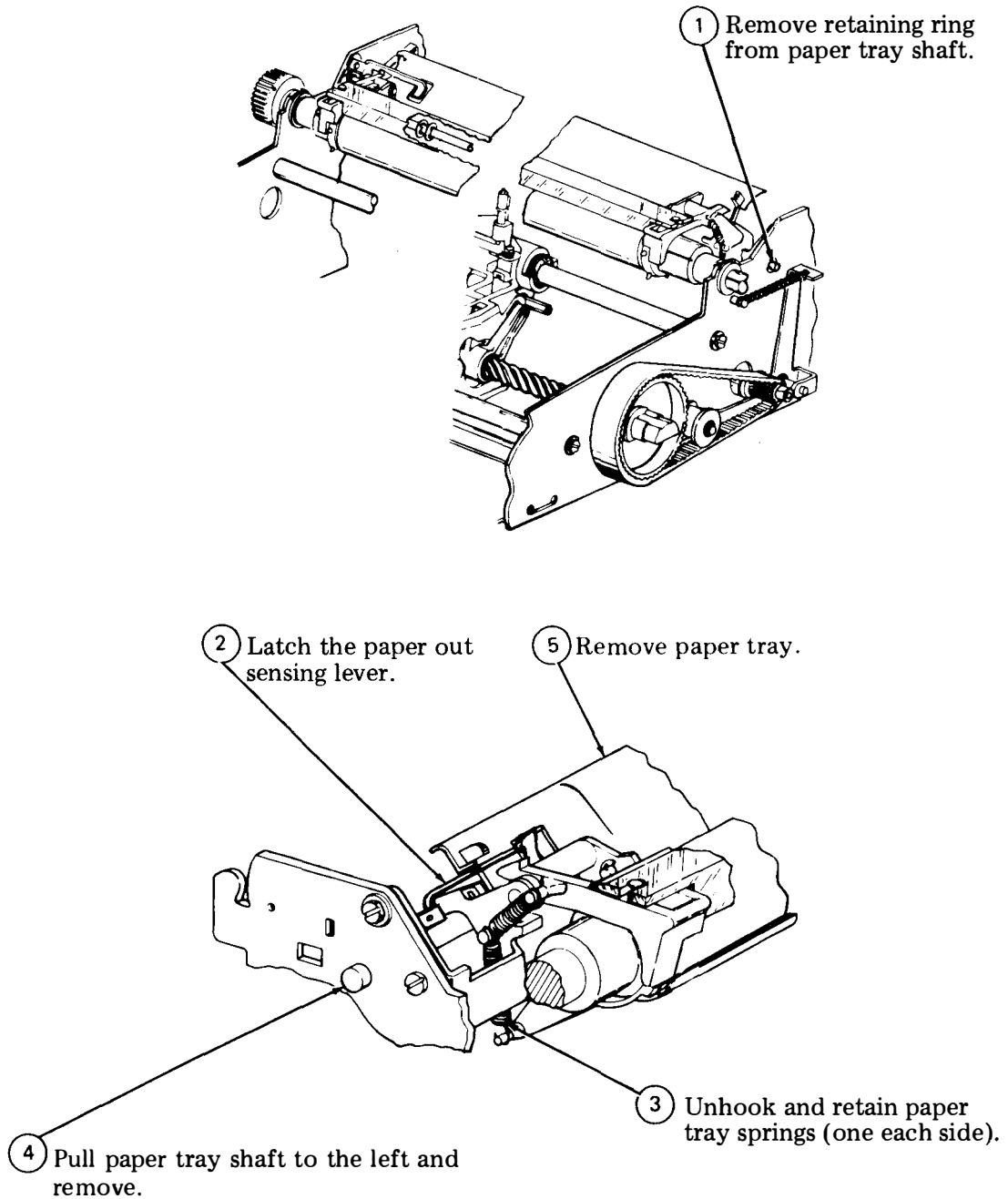



3. 12 INCH PRINTER DISASSEMBLY/REASSEMBLY (Contd)

PAPER TRAY (Contd)

(d) Friction Feed

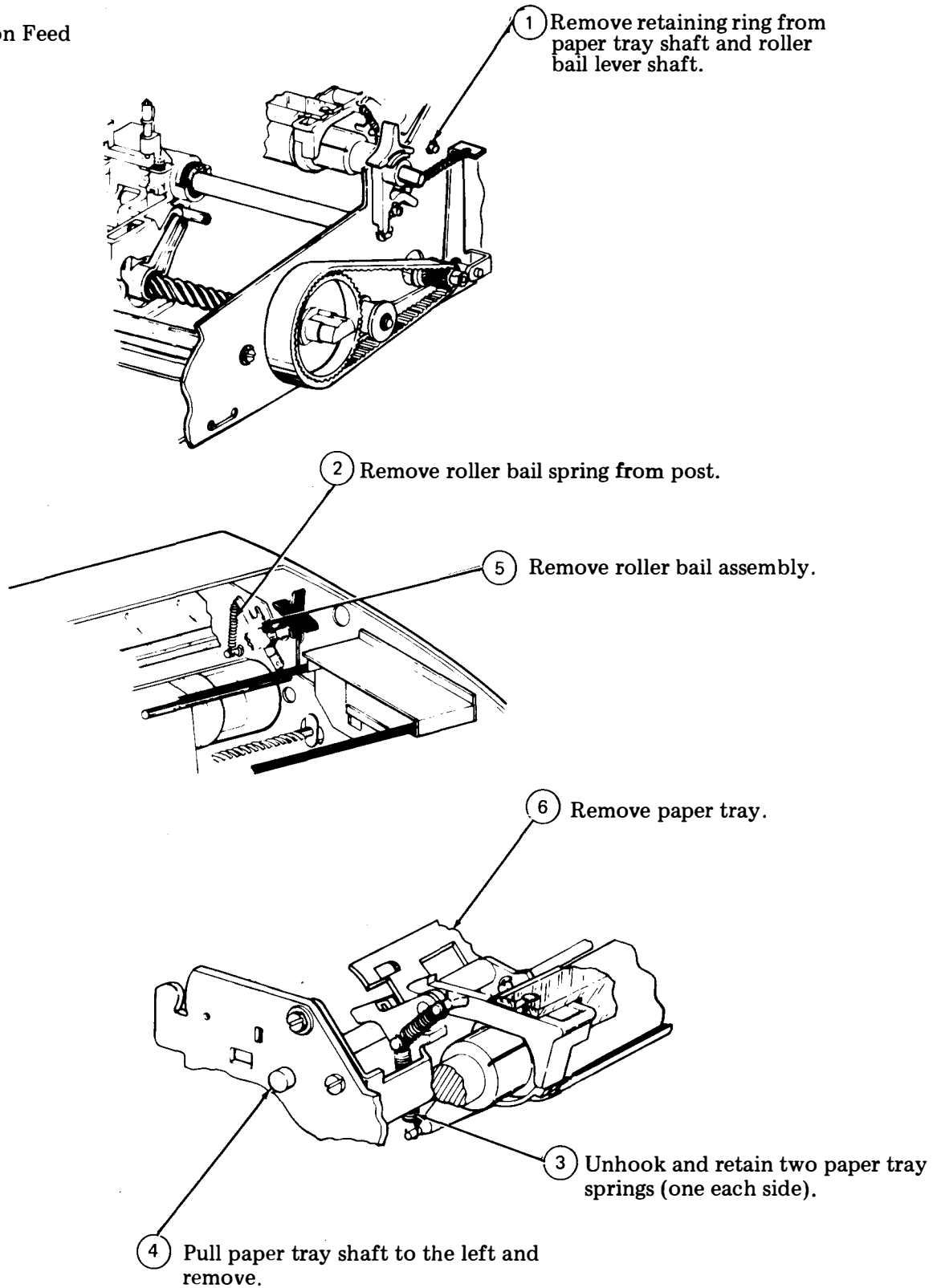

*Note:* In reassembly, verify left end of roller bail assembly is placed between two guides on paper tray.

(e) Tractor Feed

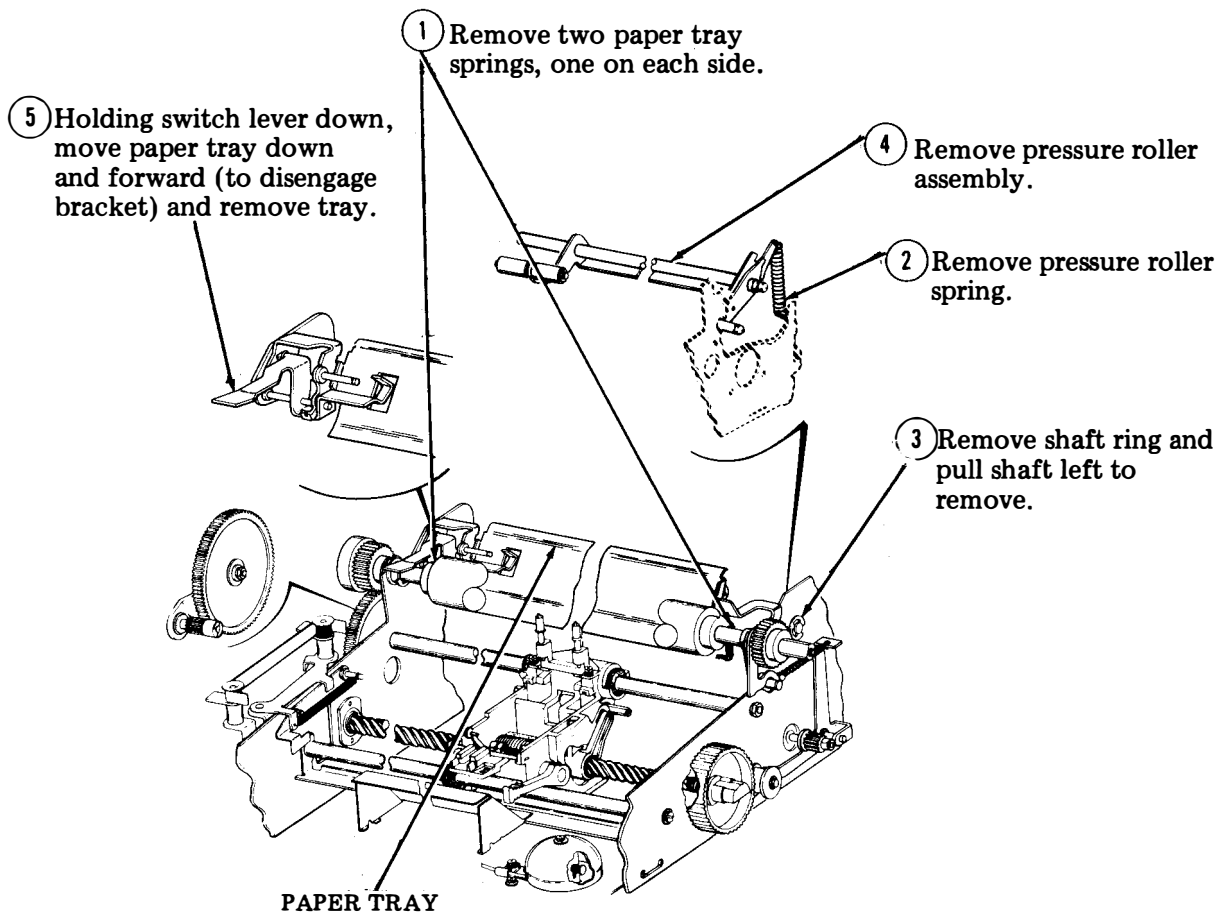

*Note:* In reassembly, verify that left end of pressure roller assembly is placed between two guides on paper tray.

3. 12 INCH PRINTER DISASSEMBLY/REASSEMBLY (Contd)

PAPER GUIDES

3.21 To remove the paper guide:

(a) Sprocket Feed, Early Design

*Note 1:* Left and right guides are removed in a similar manner.

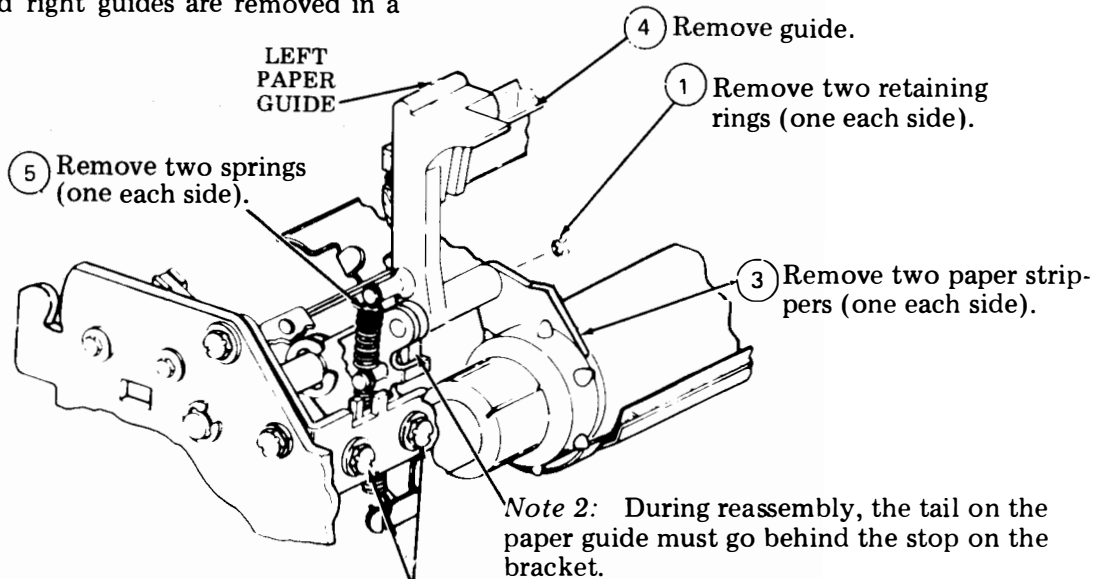

*Note 2:* During reassembly, the tail on the paper guide must go behind the stop on the bracket.

6 Remove left and right paper guides from posts on brackets.

2 With paper guides up, loosen mounting screws friction tight; position paper guide bracket toward the frame by using a screwdriver in the pry points.

*Note 3:* In reassembly, LEFT PAPER GUIDE adjustment must be made.

(b) Friction Feed and Late Design Sprocket Feed

*Note 1:* Left and right guides are removed in a similar manner.

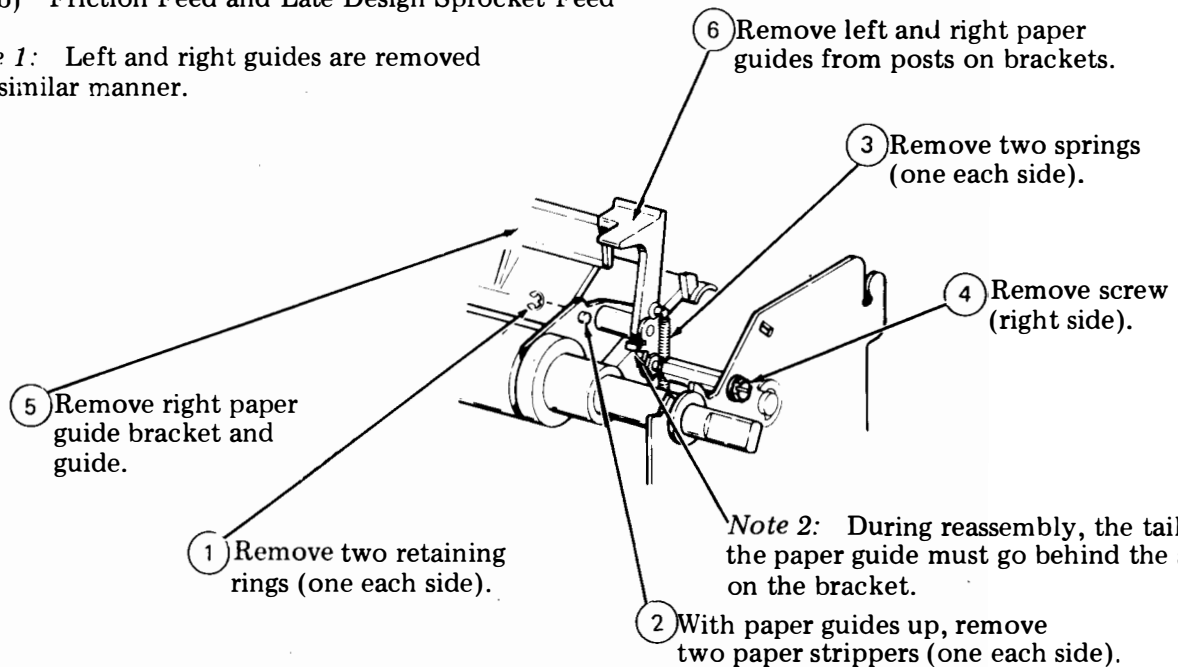

*Note 2:* During reassembly, the tail on the paper guide must go behind the stop on the bracket.

2 With paper guides up, remove two paper strippers (one each side).

*Note 3:* In reassembly, RIGHT PAPER GUIDE adjustment must be made.

TRACTOR MECHANISM

3.22 To remove the tractor mechanism:

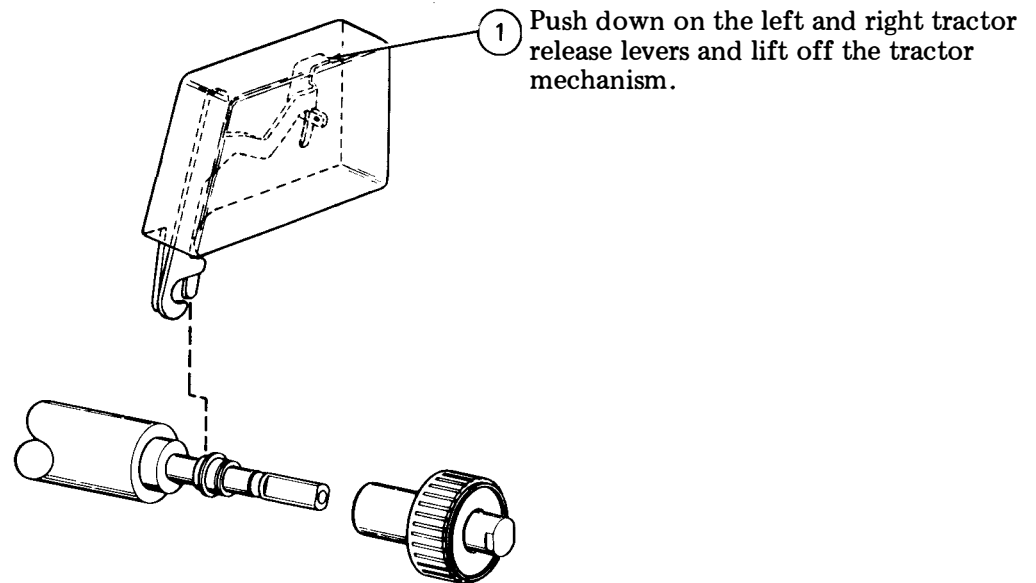

3.23 To disassemble the tractor mechanism:

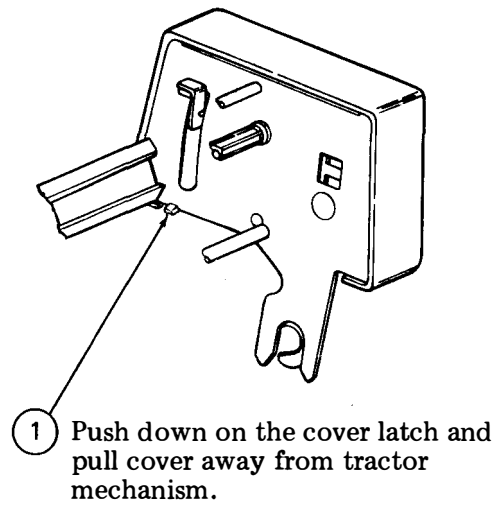

3. 12 INCH PRINTER DISASSEMBLY/REASSEMBLY (Contd)TRACTOR MECHANISM (Contd)

3.24 To reassemble the tractor mechanism:

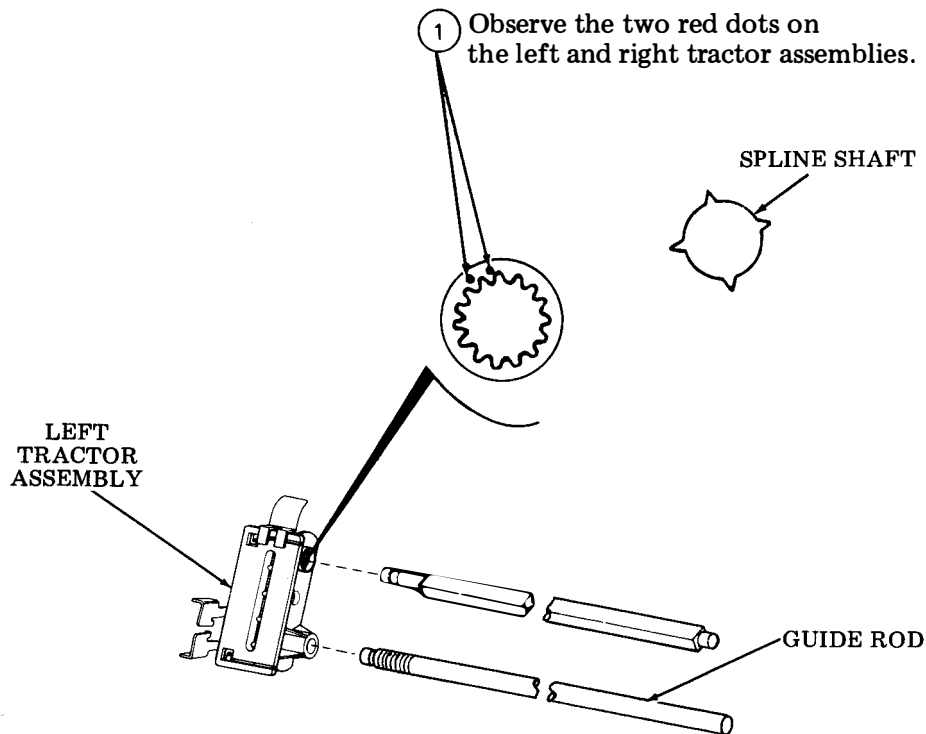

- ② Squeeze the tractor release levers together and slide the right tractor assembly onto the guide rod and the spline shaft. Be sure the release lever is facing the right side frame. When sliding onto the spline shaft make sure one of the splines fits into the sprocket located between the two red dots shown in ①.

- ③ Squeeze the tractor release levers together and slide the left tractor assembly onto the guide rod and the spline shaft. When sliding onto the spline shaft, make sure the sprocket located between the two red dots (shown in ①) fits over the same spline as the left tractor assembly.

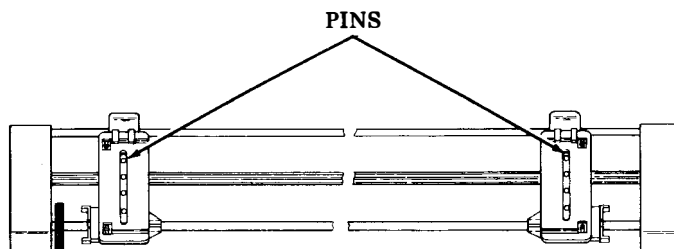

- ④ Reassemble the remainder of the components removed in (b).

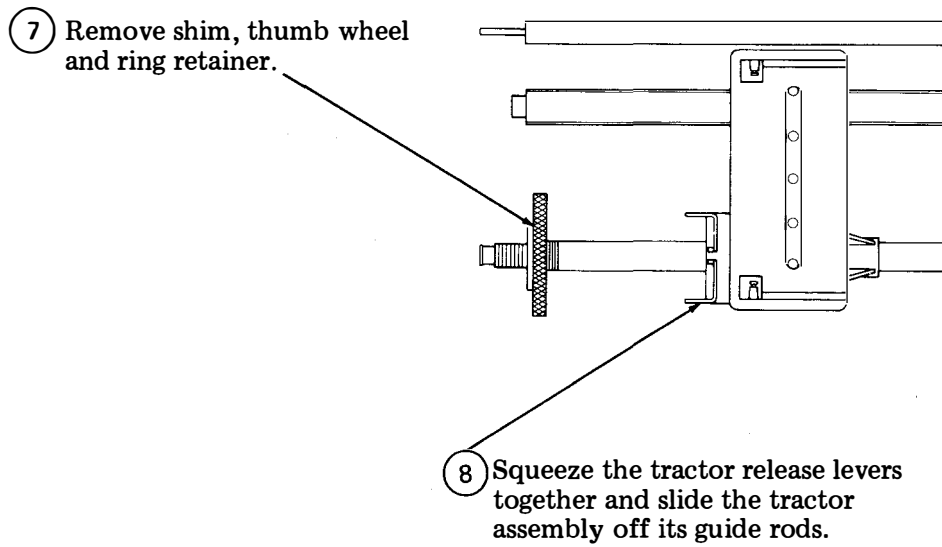
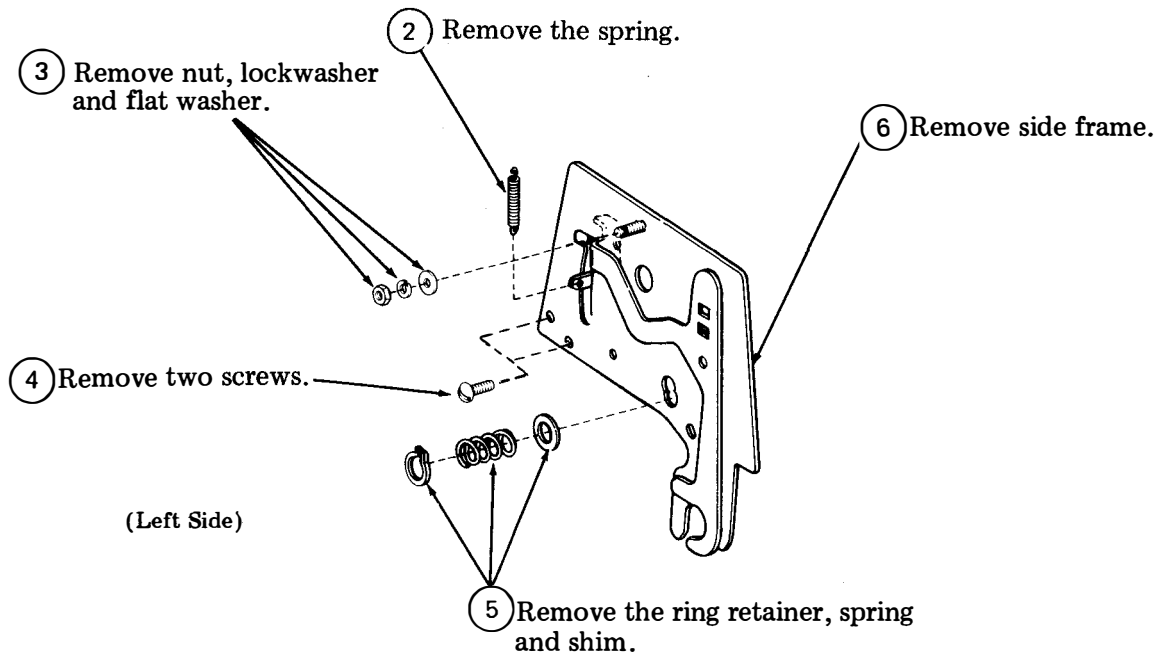

4. 15 INCH PRINTER DISASSEMBLY/REASSEMBLY

PRINT HEAD WITH COVER

4.01 To remove the print head with cover:

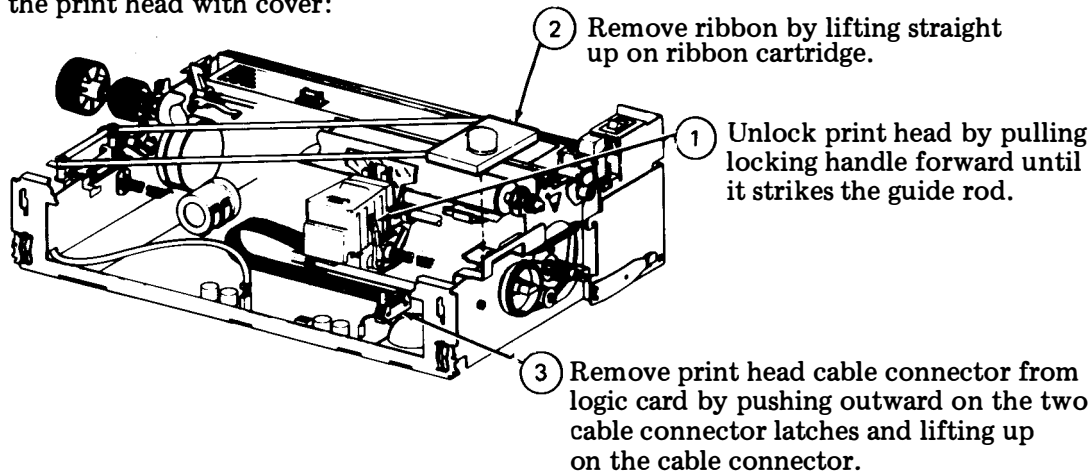

⑥ Grasp print head and pull forward. Lift front of print head to disengage locking channels.

④ Move retaining clip on locking handle extension protruding from left side of carriage wall approximately 1/4 inch away from wall. (Pry with screwdriver.)

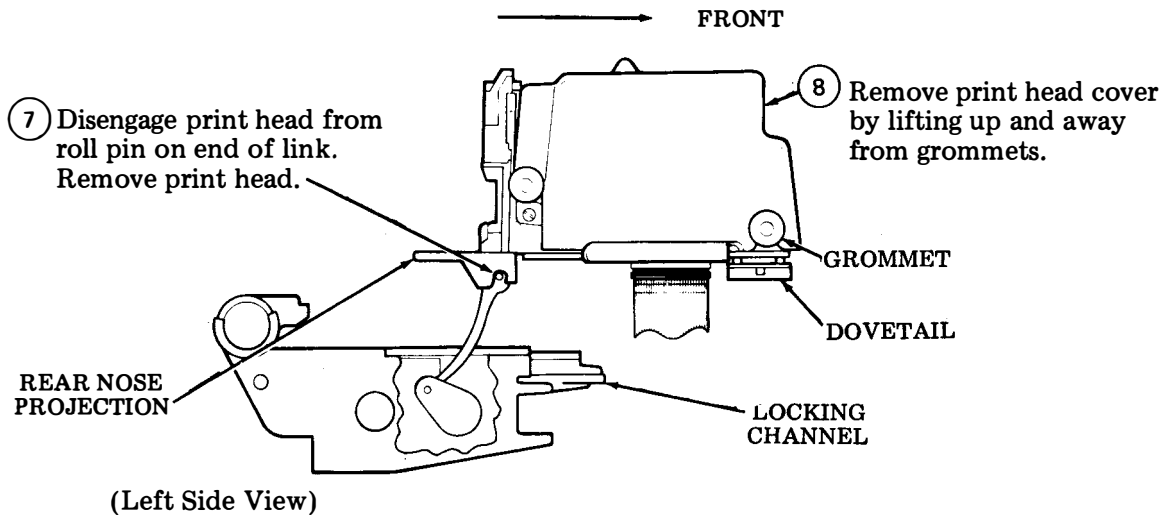
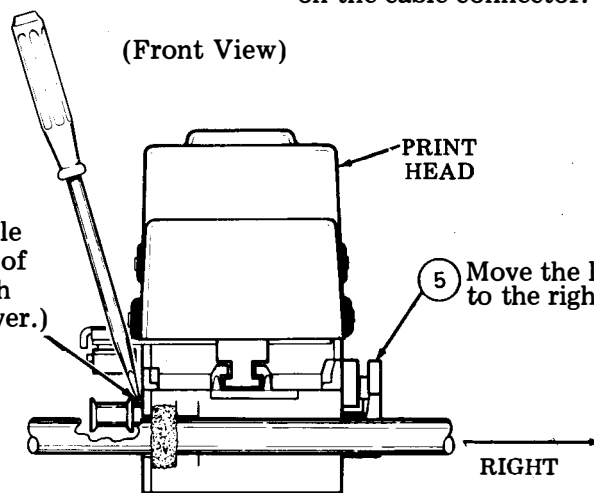

4.02 To replace the print head with cover:

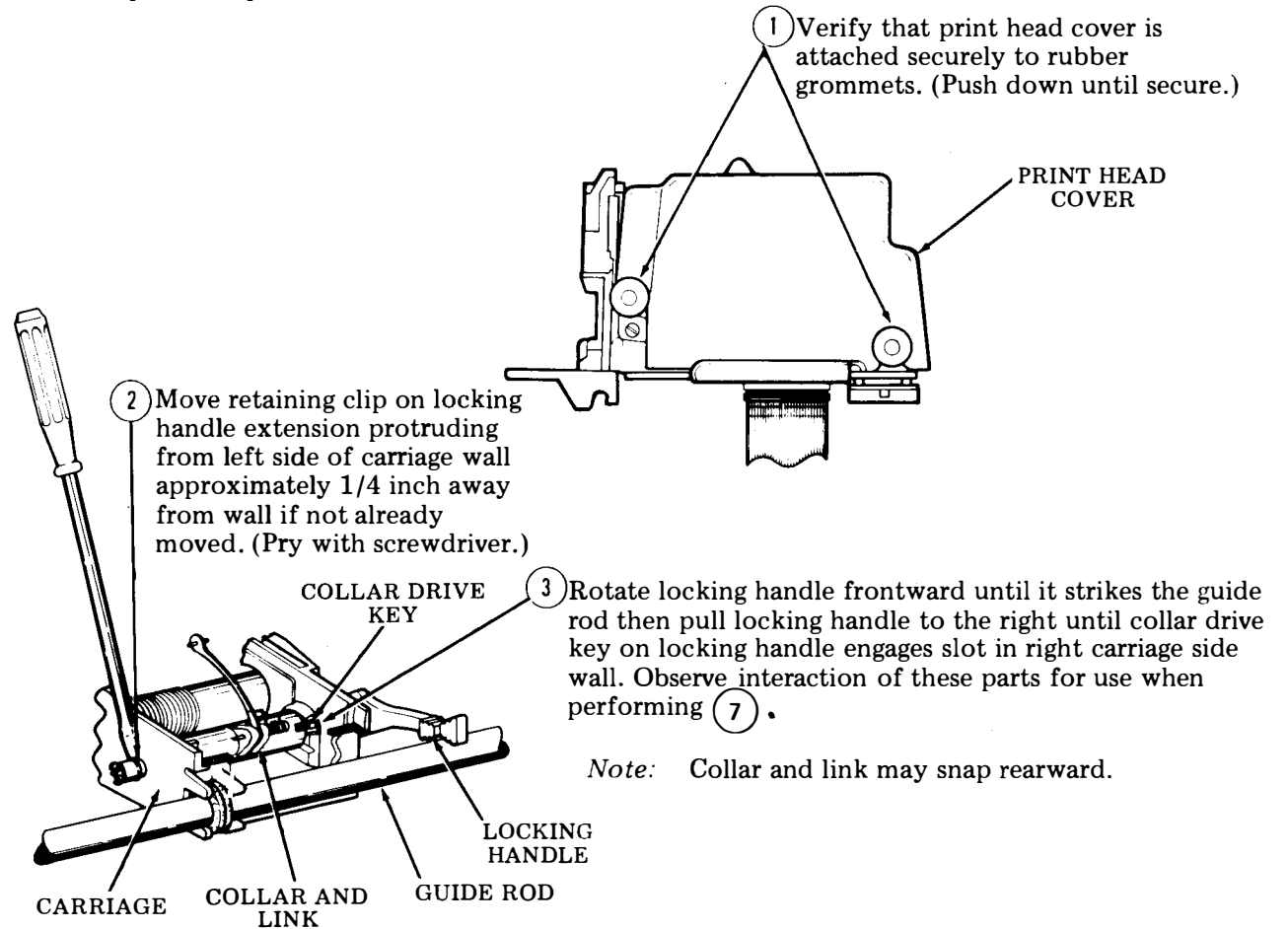

Note: Collar and link may snap rearward.

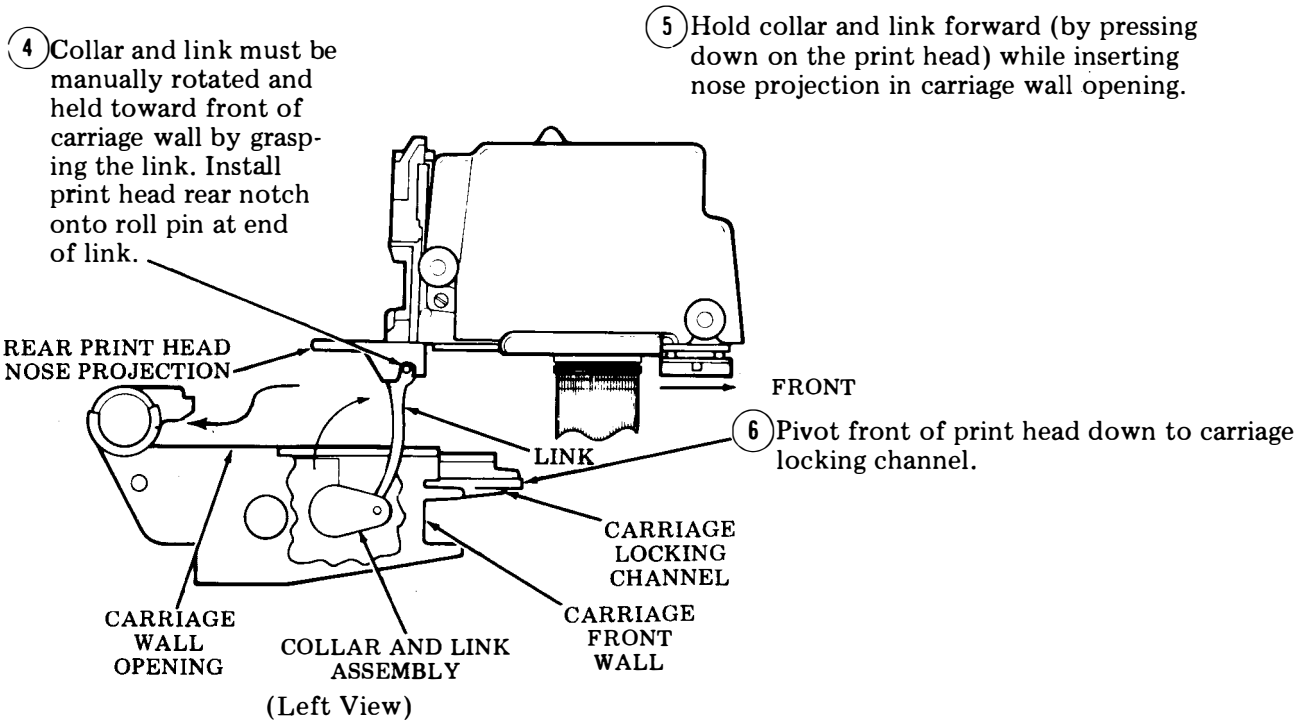



4. 15 INCH PRINTER DISASSEMBLY/REASSEMBLY (Contd)

PRINTER HEAD WITH COVER (Contd)

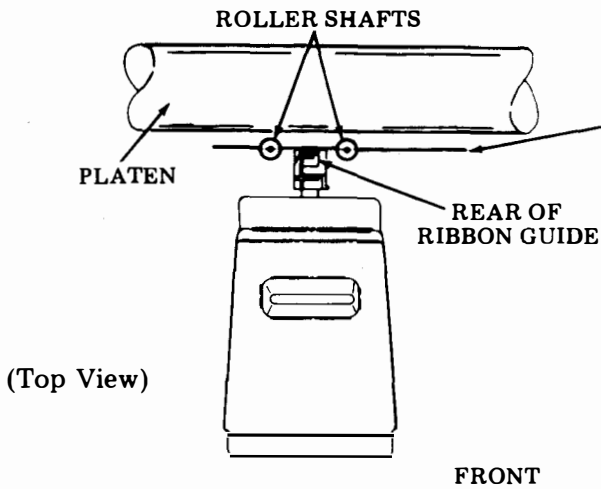

7 Slowly push print head rearward and further into the carriage locking channel until the rear of the ribbon guide is even with center of roller shafts. Apply continuous leftward pressure to locking handle at its pivot shaft, while slowly pulling print head forward until collar drive key on handle engages (snaps) into slot in collar.

Note: Parts referred to were visible in (3).

9 Position and hold print head and carriage assembly to right side of printer and use a 5/16 inch socket wrench to push clip against carriage wall.

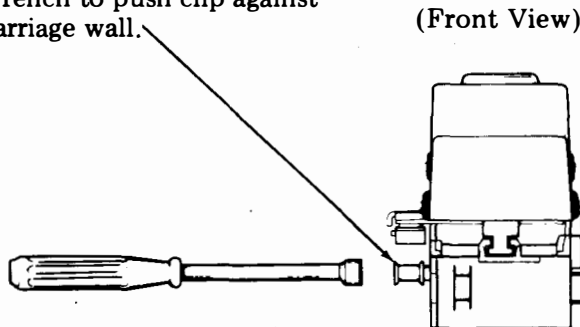

8 Move the handle all the way to the rear, locking the print head in close proximity to the platen by the additional force necessary to detent the handle. If handle does not move to rear, the drive key did not properly engage the collar slot (7).

**Warning:** Check to make sure there is some clearance between print head and platen before detenting handle. Check PRINT HEAD TO PLATEN adjustment.

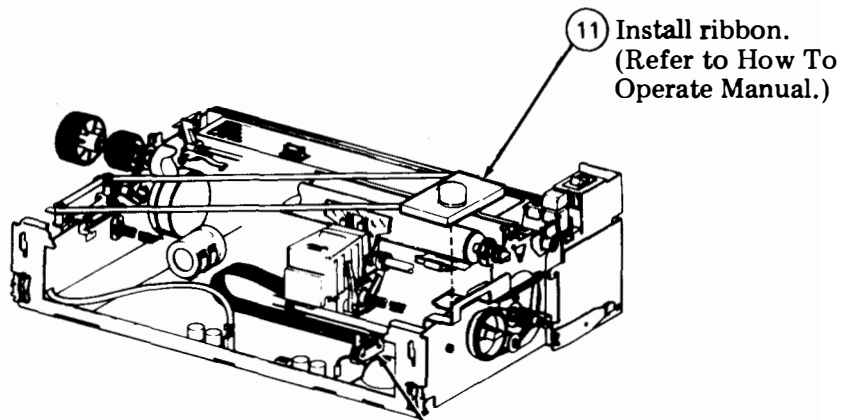

11 Install ribbon. (Refer to How To Operate Manual.)

10 Connect the print head cable plug to the logic card. Depress the cable connector until the latches snap over the connector.

4.03 To remove the cover:

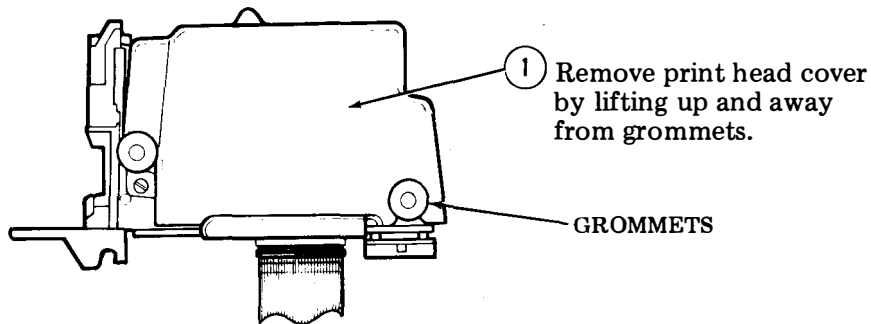

4.04 To remove the cable:

① Remove print head cover (perform 4.03, ①).

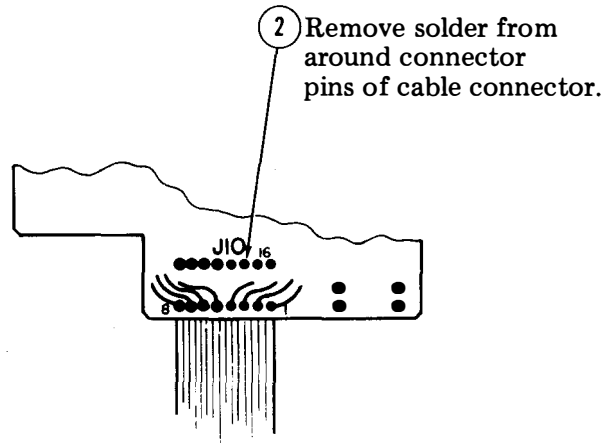

**Warning:** Use a grounded, low-wattage soldering iron (avoid prolonged contact with pins) along with a desoldering tool to prevent damage to card circuits and components.

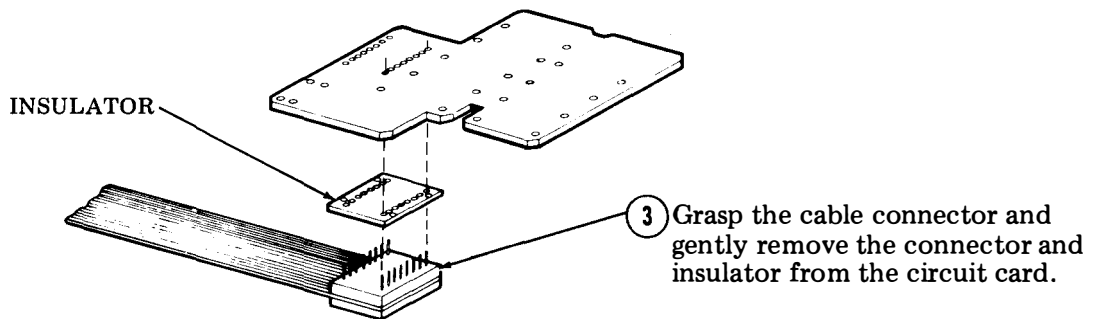

**Note:** In reassembly, make sure insulator is positioned between cable connector and circuit card as shown.

4. 15 INCH PRINTER DISASSEMBLY/REASSEMBLY (Contd)

PRINT HEAD WITH COVER (Contd)

4.05 To remove the ribbon guide:

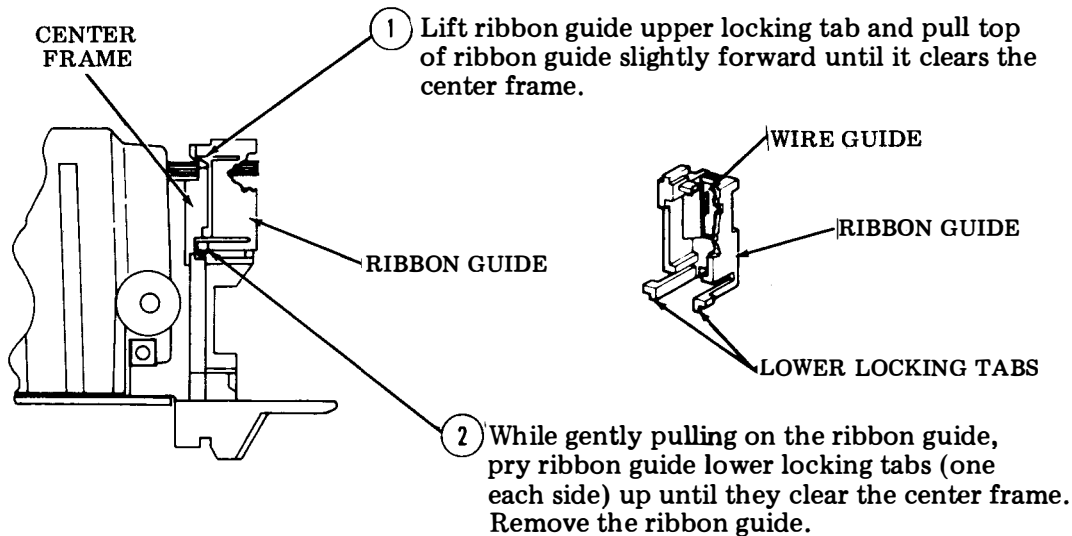

*Note:* Visually inspect the wire guide for cracks or damage whenever the ribbon guide is removed, and replace if damaged.

4.06 To replace the ribbon guide:

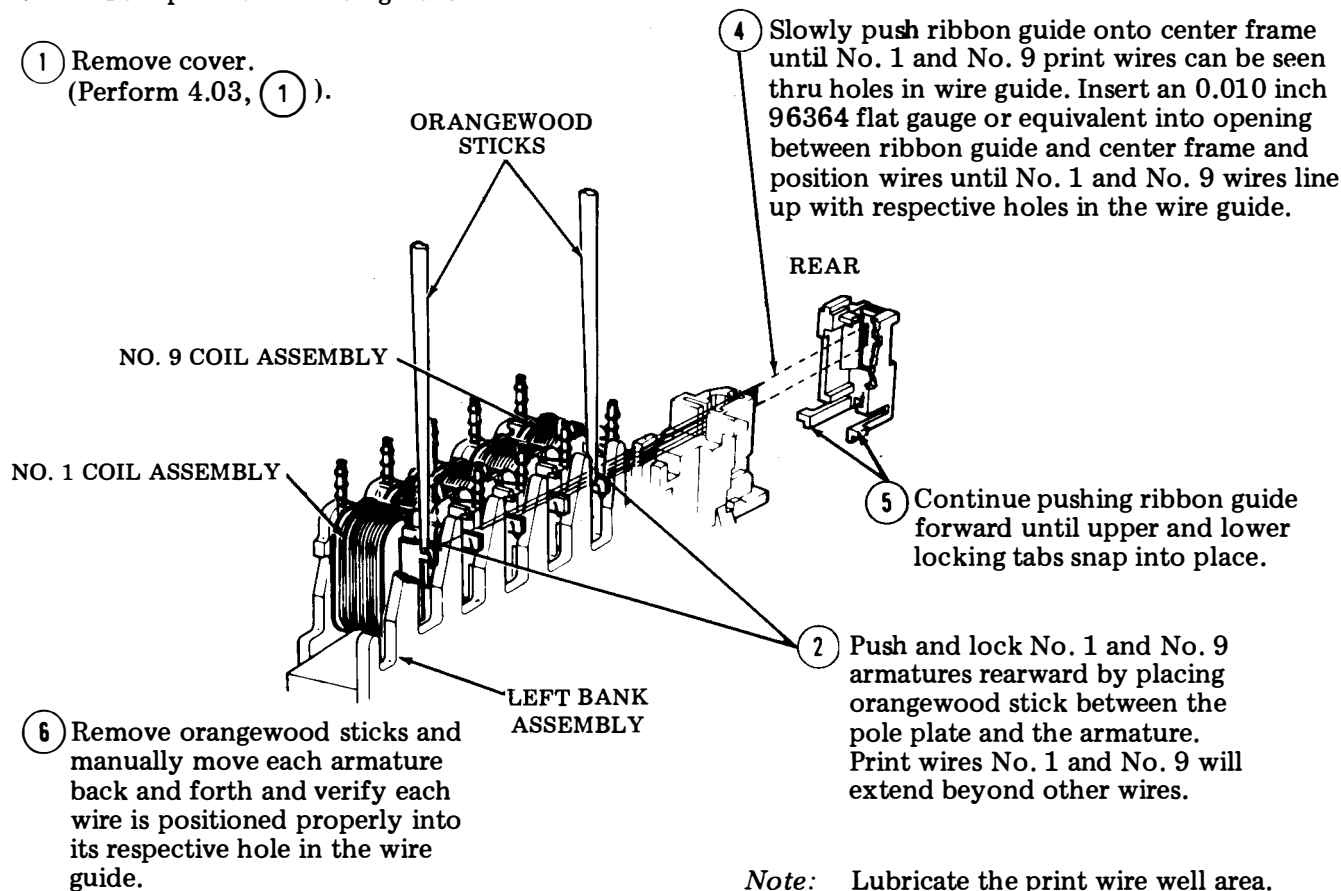

*Note:* Lubricate the print wire well area.

4.07 To remove the wire guide:

- ① Remove the ribbon guide (perform 4.05, ① and ②).

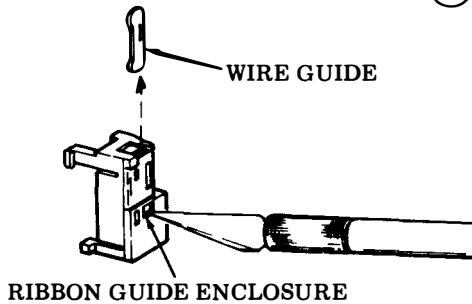

- ② Insert pointed flat blade (hobby knife) under wire guide and gently pry up until bottom of wire guide clears ribbon guide enclosure. Grasp wire guide and pull straight up to remove.

*Note:* In reassembly, insert wire guide into ribbon guide as shown above and push down until bottom of wire guide is against bottom of ribbon guide enclosure.

4.08 To remove the sleeve:

- ① Remove the cover (perform 4.03, ①).

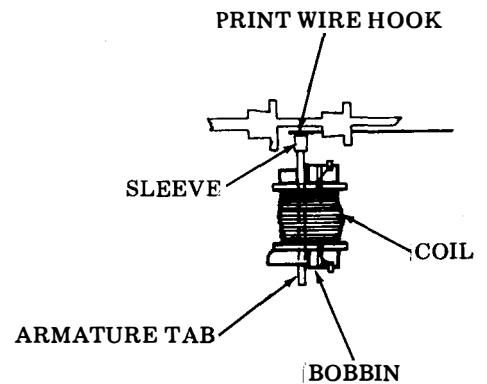
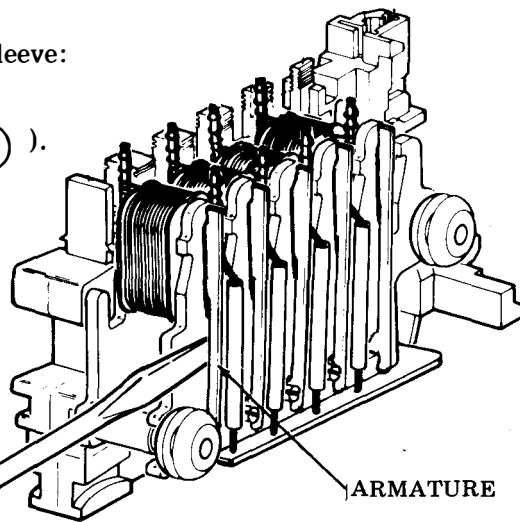

- ② Pry armature gently outward (away from print wires) until sleeve slides free of print wire hook and armature tab clears bobbin.

- ③ Grasp armature and push toward ribbon guide (magnet will pull armature away from ribbon guide) until armature touches bobbin. Pull armature and sleeve gently outward.

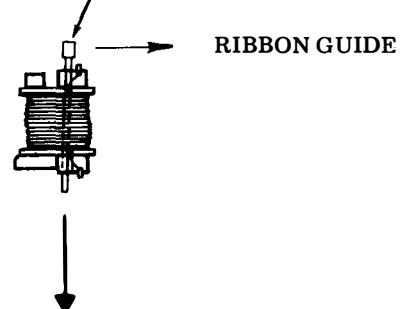
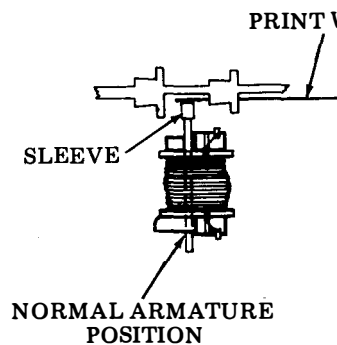

- ④ Remove sleeve from armature extension.

*Note:* In reassembly, make sure sleeve is positioned over grooves in armature extension and flush with extension edge. Lubricate any armatures removed and replaced.

4. 15 INCH PRINTER DISASSEMBLY/REASSEMBLY (Contd)

PRINT HEAD WITH COVER (Contd)

4.09 To remove the coil assembly:

- ① Remove print head cover (perform 4.03, ①).

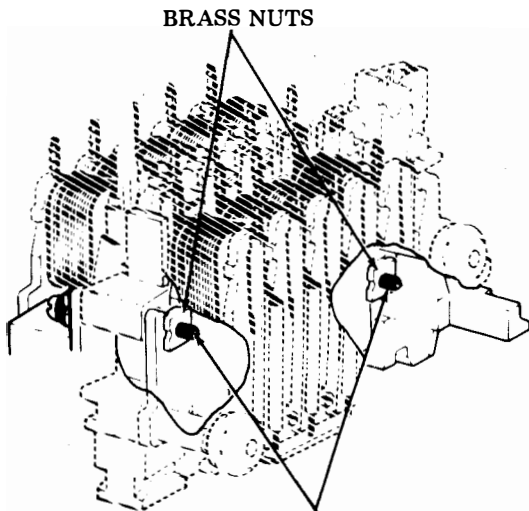

- ② Loosen two pole plate screws.

- ③ Remove armature (perform 4.08, ② and ③).

**Note:** In reassembly, note positioning of brass nuts and verify correct position as shown before tightening screws. Lubricate any armatures removed and replaced.

- ⑤ Pry locking tab on bobbin until it clears the pole plate.
- ⑥ Pull the coil assembly straight up and remove. Use a spring hook.

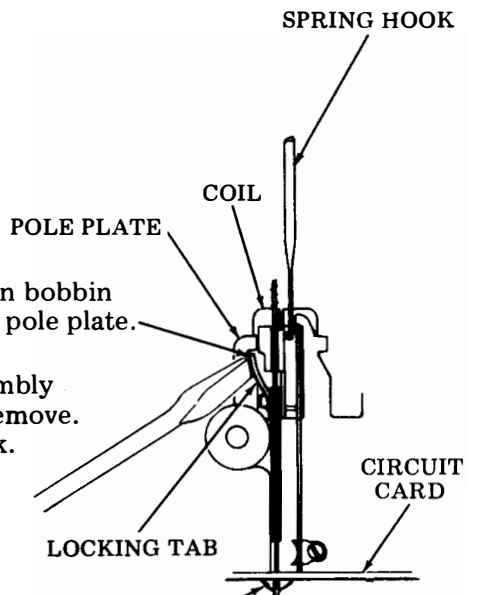

- ④ Remove solder from around coil assembly terminals.

**Warning:** Use a low wattage soldering iron (avoid prolonged contact with terminals) along with a desoldering tool to prevent damage to circuitry.

SPACING MOTOR BELT

4.10 To remove the spacing motor belt:

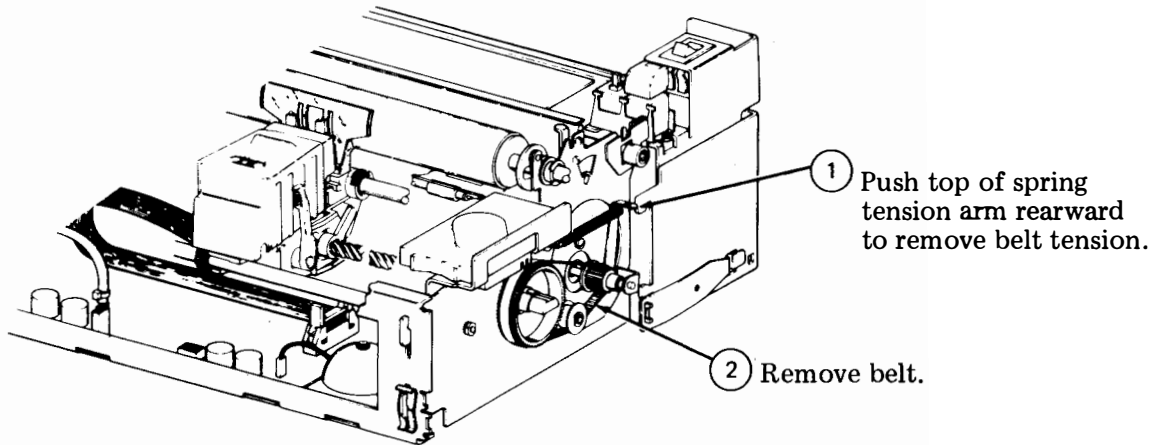

SIGNAL BELL

4.11 To remove the signal bell:

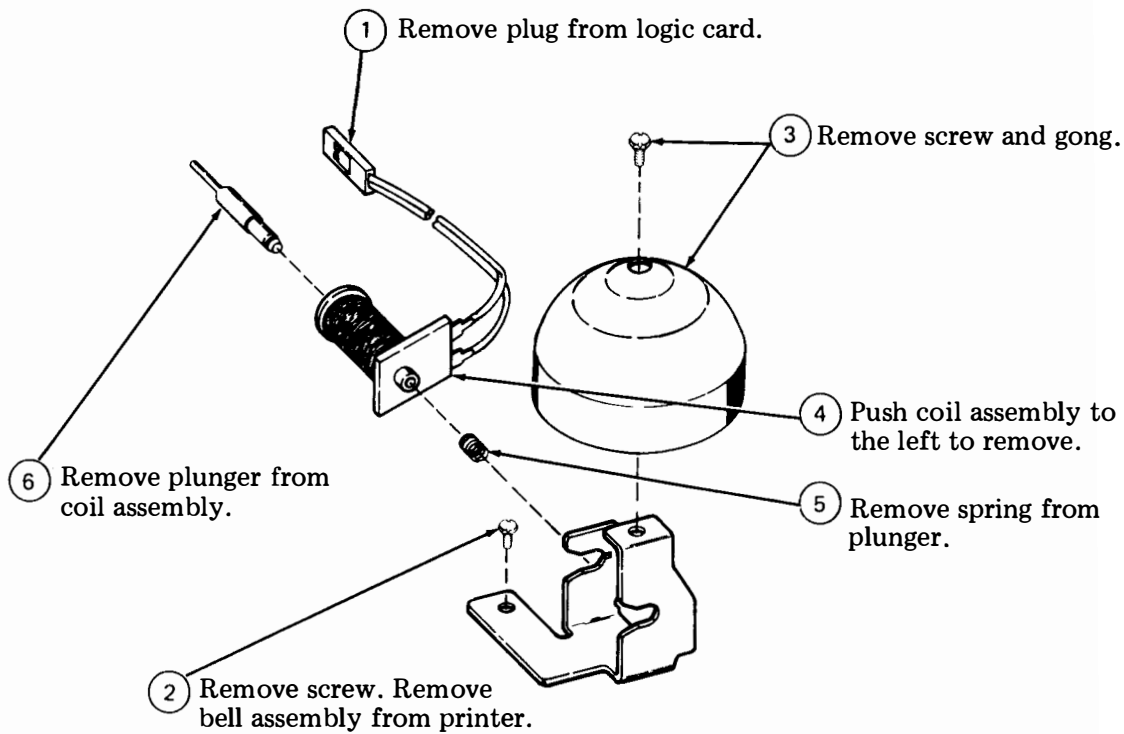

4. 15 INCH PRINTER DISASSEMBLY/REASSEMBLY (Contd)

430780 POWER SUPPLY

4.12 To remove power supply if present:

- ① Grasp outer rear edges of paper guide. Lift up and pull rearward to remove paper guide.

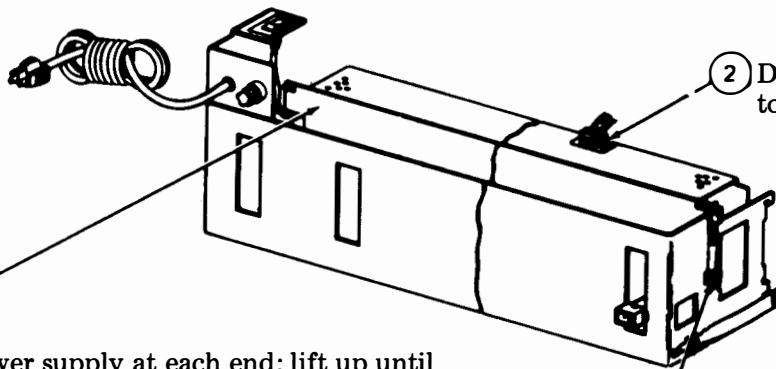
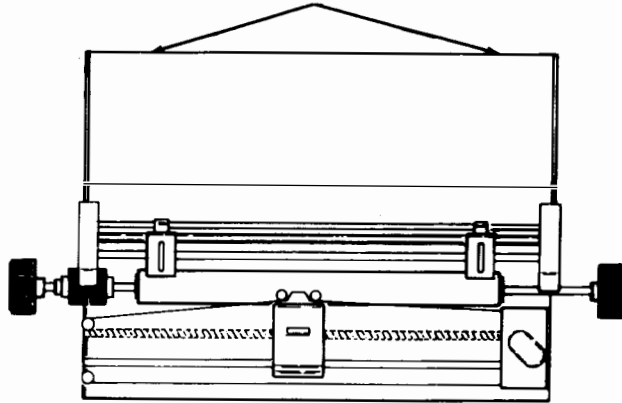

- ④ Grasp power supply at each end; lift up until ac plug can be removed. Remove ac plug and continue lifting up to remove power supply.

- ② Disconnect cable plug from top of power supply.

- ③ Use screwdriver and pry two clips (left and right) outward.

4.13 To remove power supply fuse:

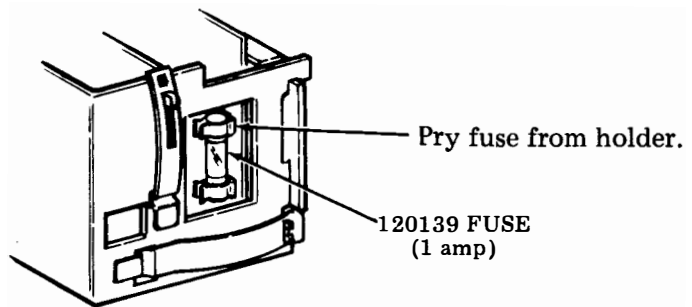

430643 LOGIC CARD

4.14 To remove the logic card:

- ① Remove paper guide (perform 4.12, ① ).

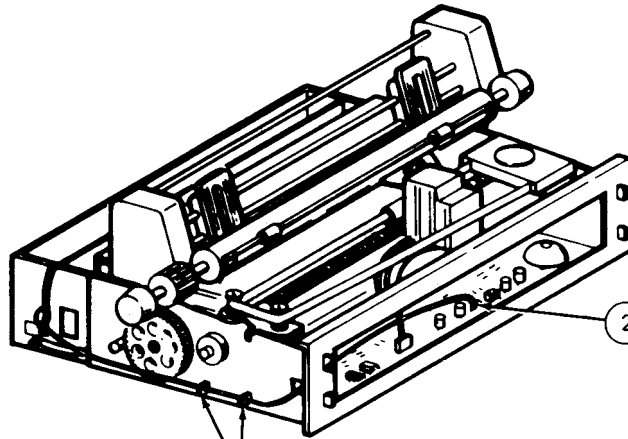

② Disconnect SSI cable connector from logic card and route cable out through printer side frame.

③ Remove cable from clamps by spreading open clamps.

- ⑥ Gently pull the rear frame to the rear while lifting to disengage the hook-shaped details at the top front of the rear plate. The hook-shaped details fit into the notches on the rear plate and hold the rear frame in place. Pull rear frame back about 6 inches.

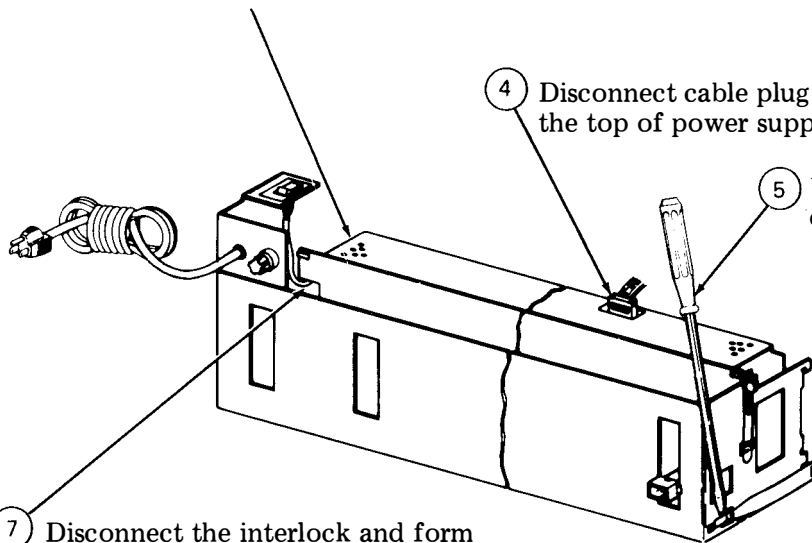

④ Disconnect cable plug from the top of power supply.

⑤ Use screwdriver and pry two clips (left and right) outward.

⑦ Disconnect the interlock and form feed cable from the logic card and remove the rear frame.



4. 15 INCH PRINTER DISASSEMBLY/REASSEMBLY (Contd)

430643 LOGIC CARD (Contd)

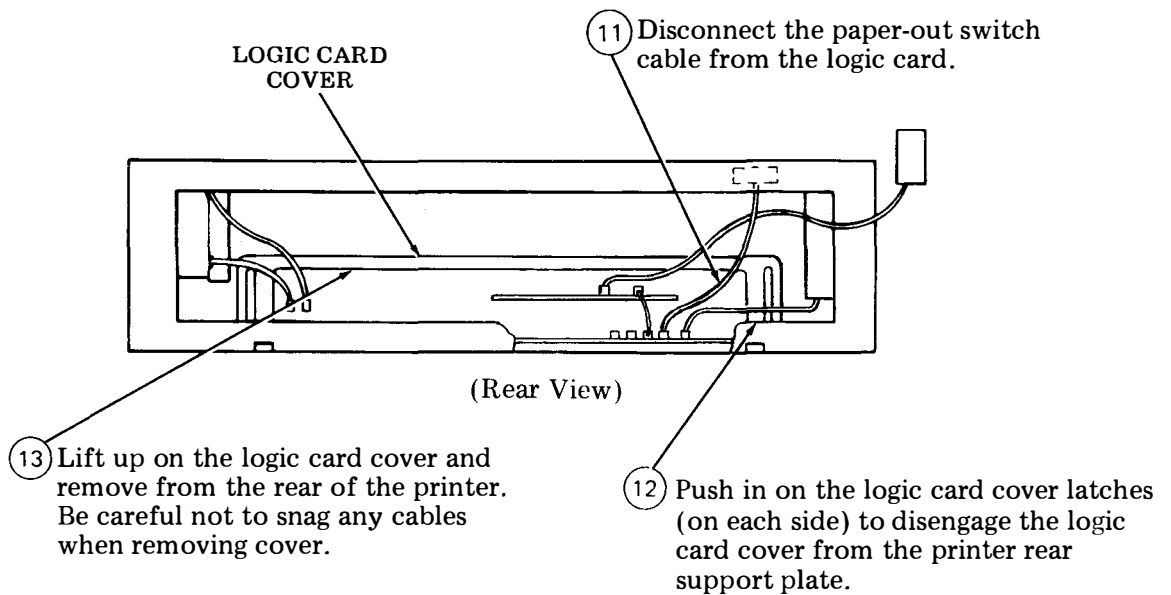
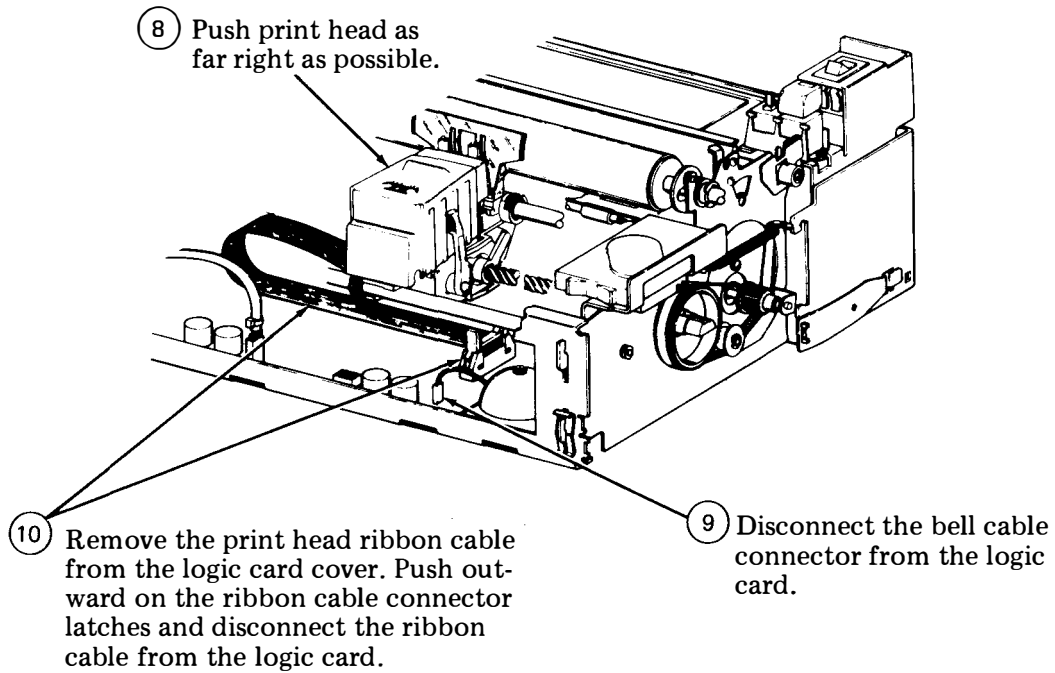

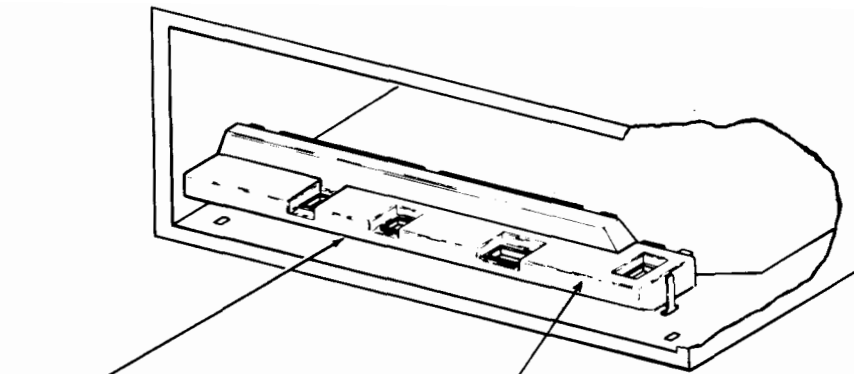

Front portion logic card cover.

(Front View)

- 14 Install the front portion of the logic card cover making sure the two hooks (left and right) are in the two holes in the printer bottom plate. Lock in place by sliding forward.

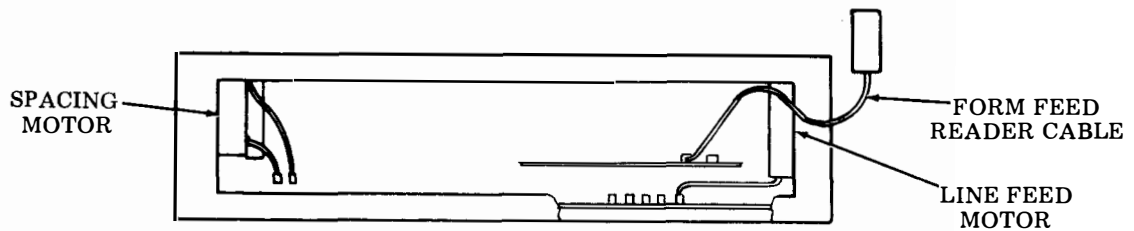

(Rear View)

- 15 Disconnect the form feed reader cable, line feed motor cable and two spacing motor cables from the logic card.

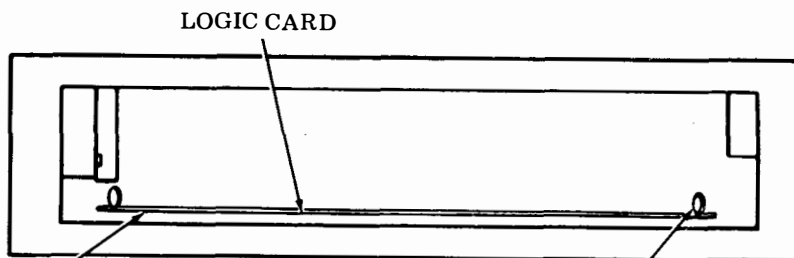

(Rear View)

- 17 Pull the logic card to the rear removing it from the printer.

- 16 Pull up on the two nylon rings at the rear of the logic card to disengage the logic card from the two circuit board supports.

4. 15 INCH PRINTER DISASSEMBLY/REASSEMBLY (Contd)

430643 LOGIC CARD (Contd)

4.15 To reinstall the logic card:

- ① Slide the logic card into the rear of the printer until the front two protrusions on the logic card extend through the slots in the front of the printer frame.
- ② Seat the logic card over the two circuit board supports and push down on the card until it is fully seated.

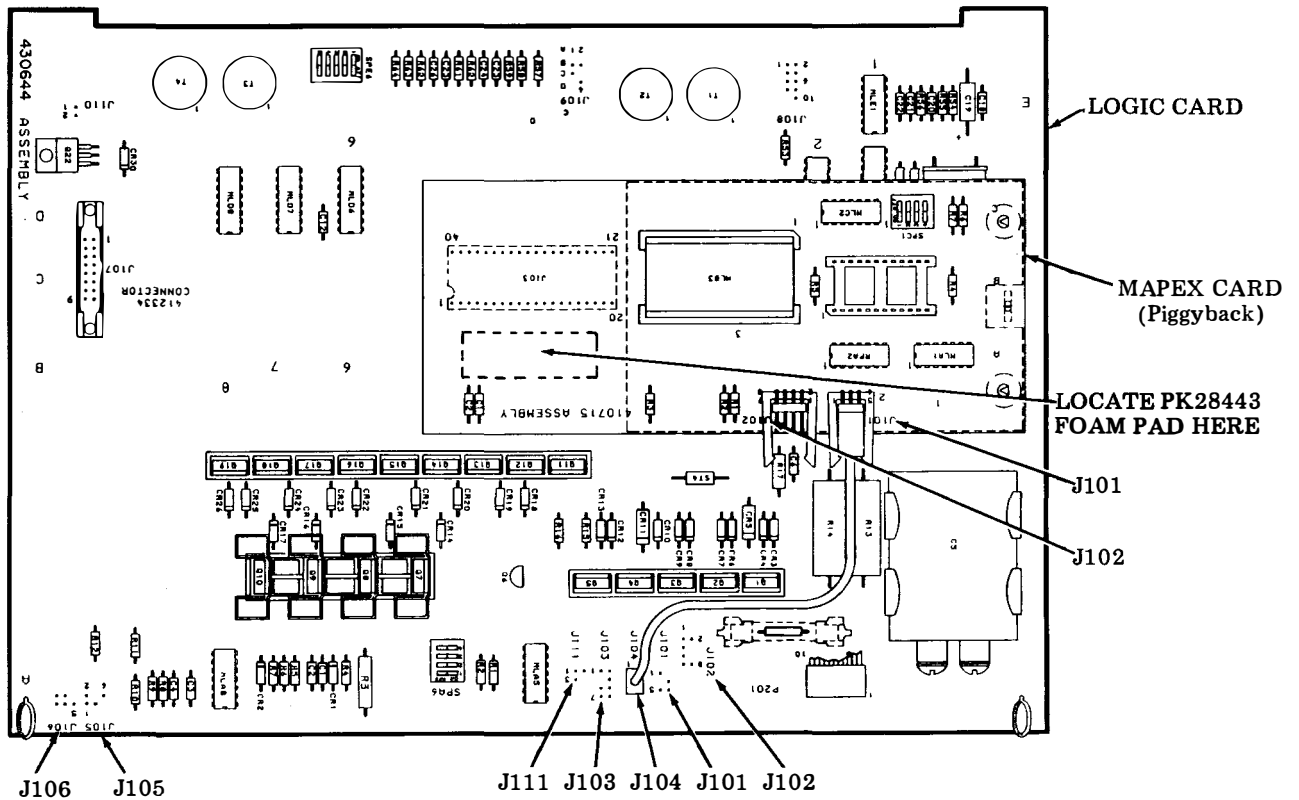

*Note:* Insure foam pad (PK28443) is located over mapex card in area shown.

- ③ Connect the spacing motor cables to J105 and J106. Connect the line feed motor cable to J102 on the logic card and connect the form feed tape reader cable to J102 on the 410715 mapex card.

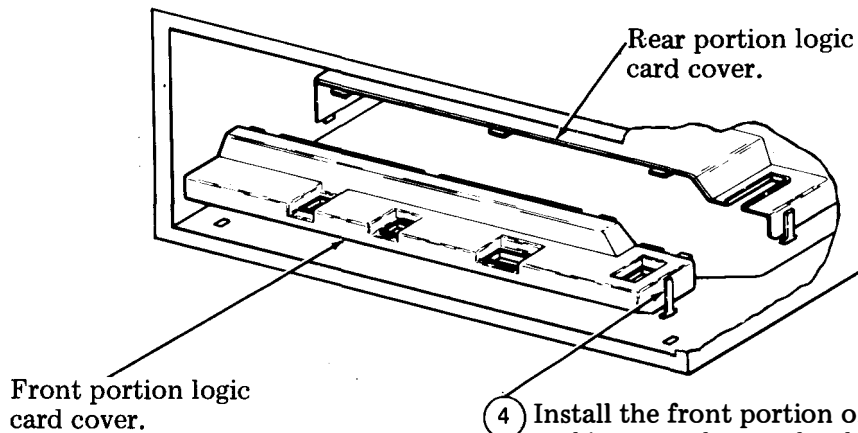

(Front View)

- ④ Install the front portion of the logic card cover making sure the two hooks (left and right) are in the two holes in the printer bottom plate. Lock in place by sliding forward.

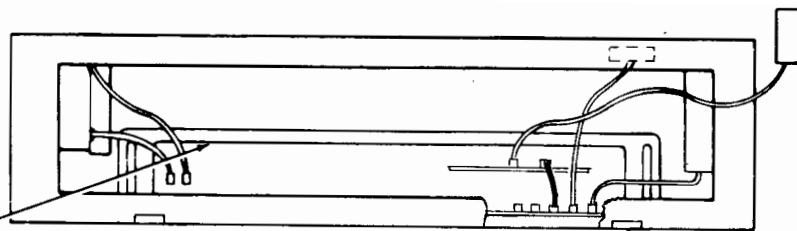

(Rear View)

- 5 Install the back portion of the logic card cover. Make sure it interlocks with the front portion and that its two (one left and one right) hooks engage the printer bottom plate (visible in 4).
- 6 Push down on logic card cover until the latches (left and right) engage the slot in the printer rear support plate.
- 7 Connect the paper-out switch cable to J101 on the logic card (see 2).
- 8 Connect the print head cable and bell cable and assemble the rear frame by reversing the removal procedures.

4. 15 INCH PRINTER DISASSEMBLY/REASSEMBLY (Contd)

SPACING MOTOR WITH CABLE AND ENCODER

4.16 To remove the spacing motor:

- ① Remove the rear frame and back portion of the logic card cover (perform 4.14 ① through ⑬ except ⑨).

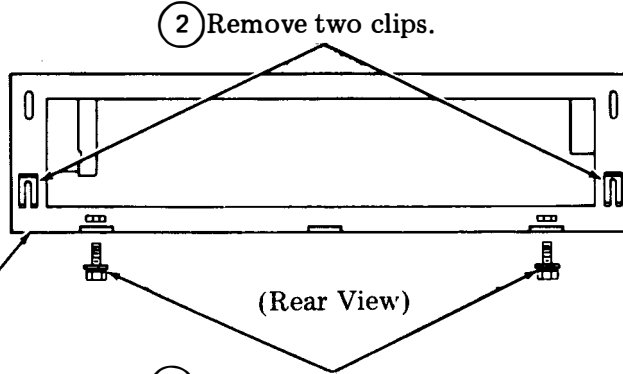

- ③ Remove two screws and two nuts.

- ④ Pull back on the bottom of the rear support plate then lift up to unhook from the side frames.

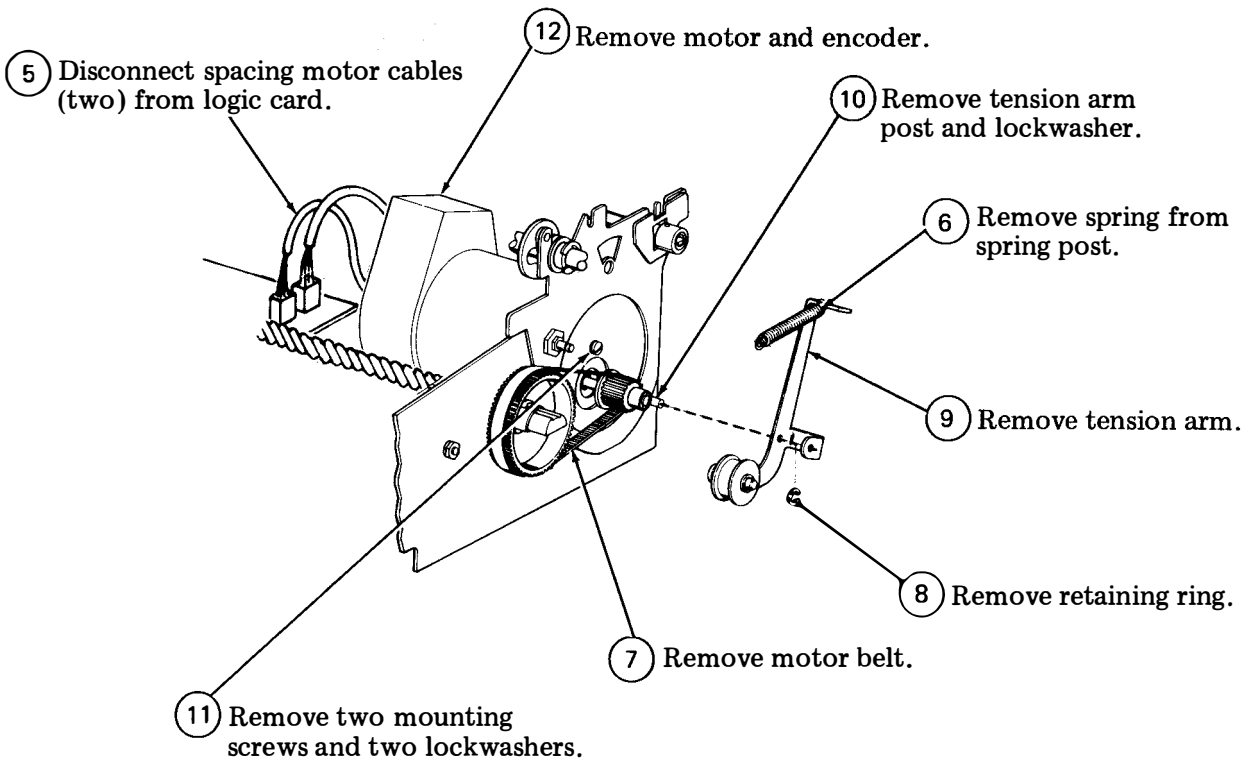

430441 motor with cable and encoder.

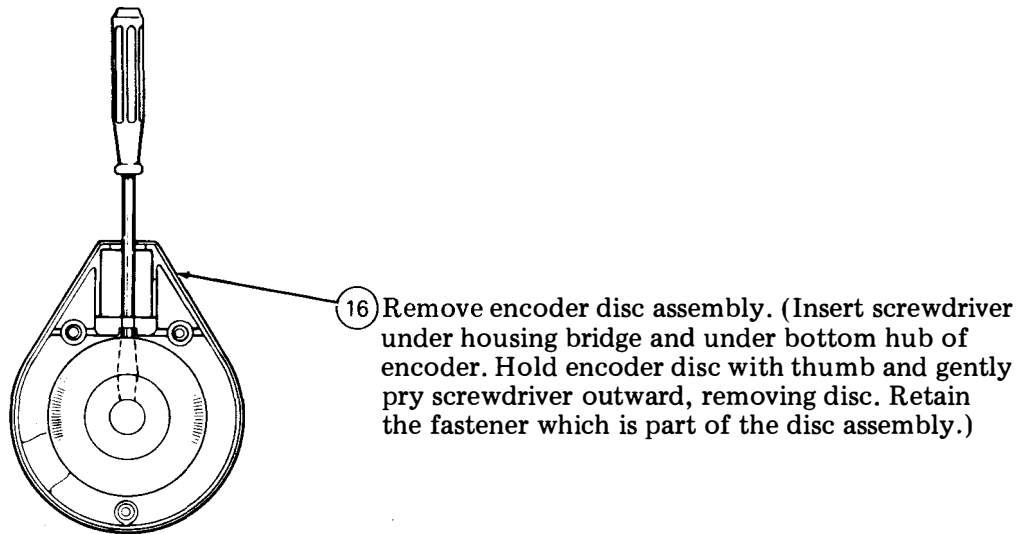
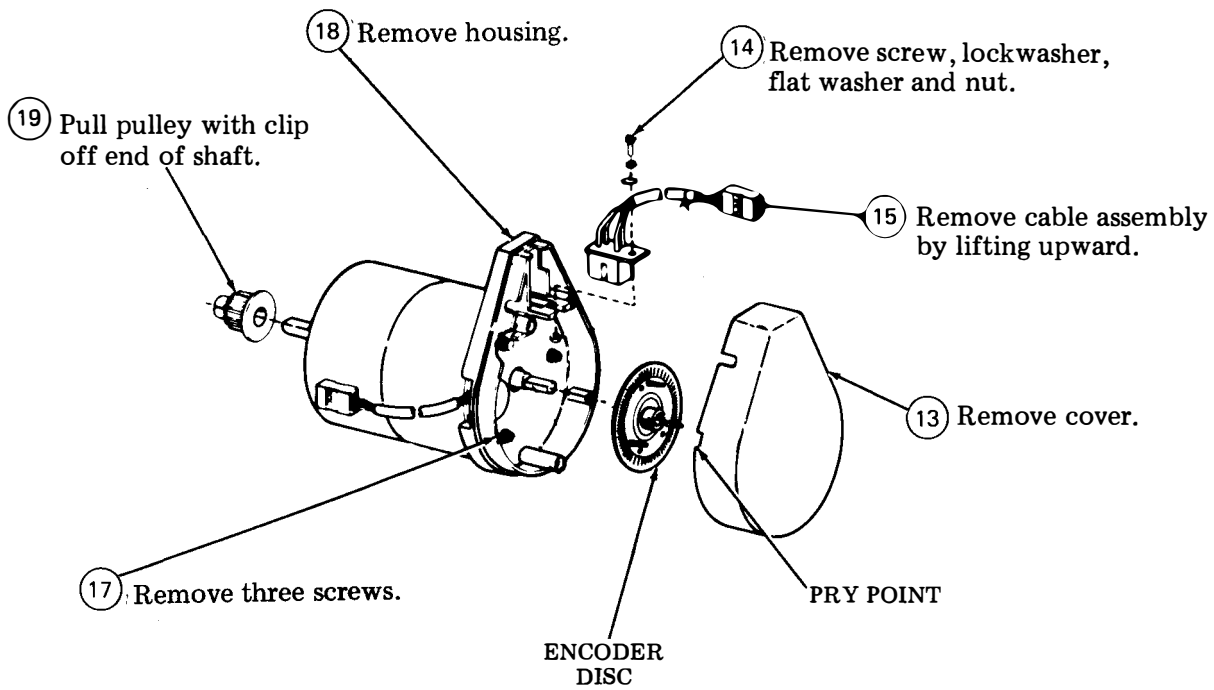

**Warning:** In reassembly, make sure disc does not rub on encoder assembly.

4. 15 INCH PRINTER DISASSEMBLY/REASSEMBLY (Contd)

LINE FEED MOTOR

4.17 To remove the line feed motor:

- ① Remove the rear frame assembly. Perform 4.14, ① through ⑦ .
- ② Disconnect the line feed motor cable from the logic card.

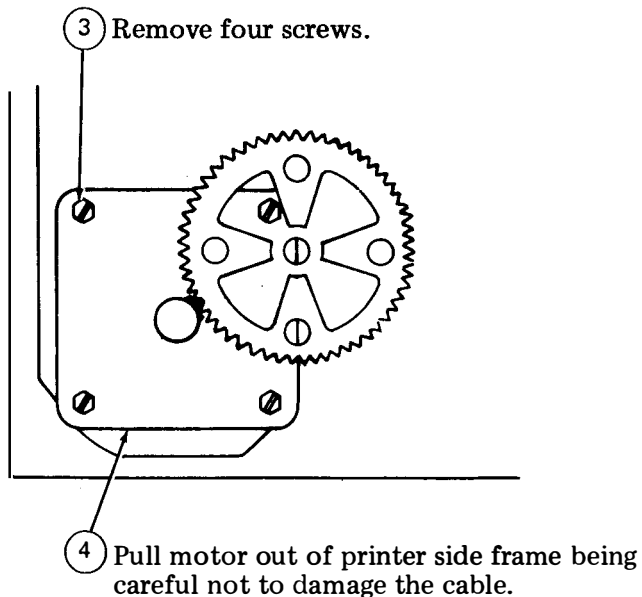

*Note:* In reassembly, perform IDLER GEAR TO PLATEN GEAR adjustment.

PAPER TENSIONER ARM

4.18 To remove the paper tensioner arm:

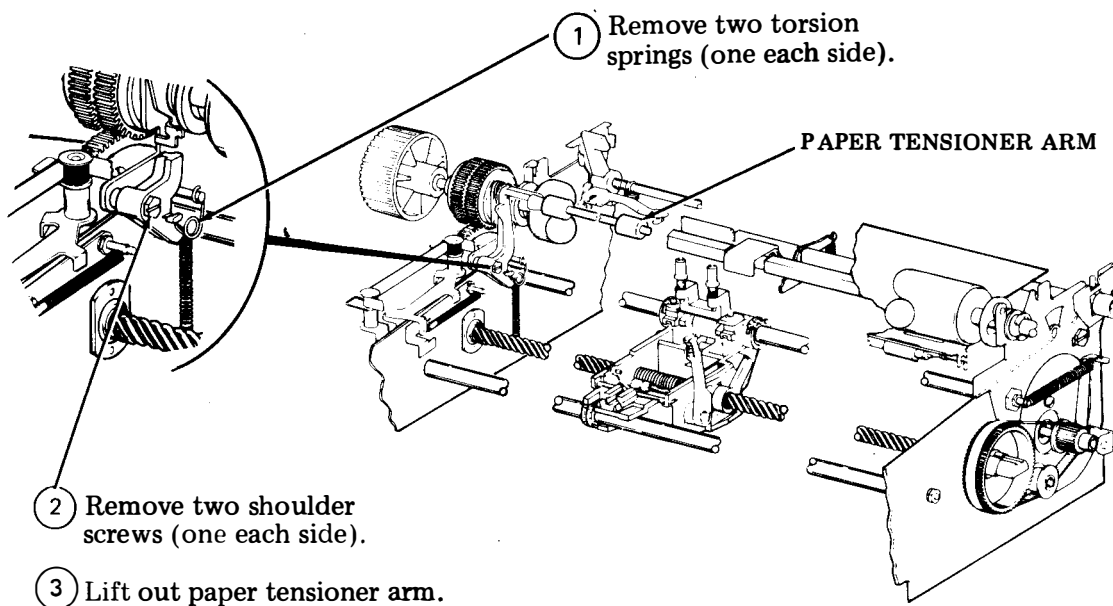

TRACTOR MECHANISM

4.19 (a) To remove the tractor mechanism:

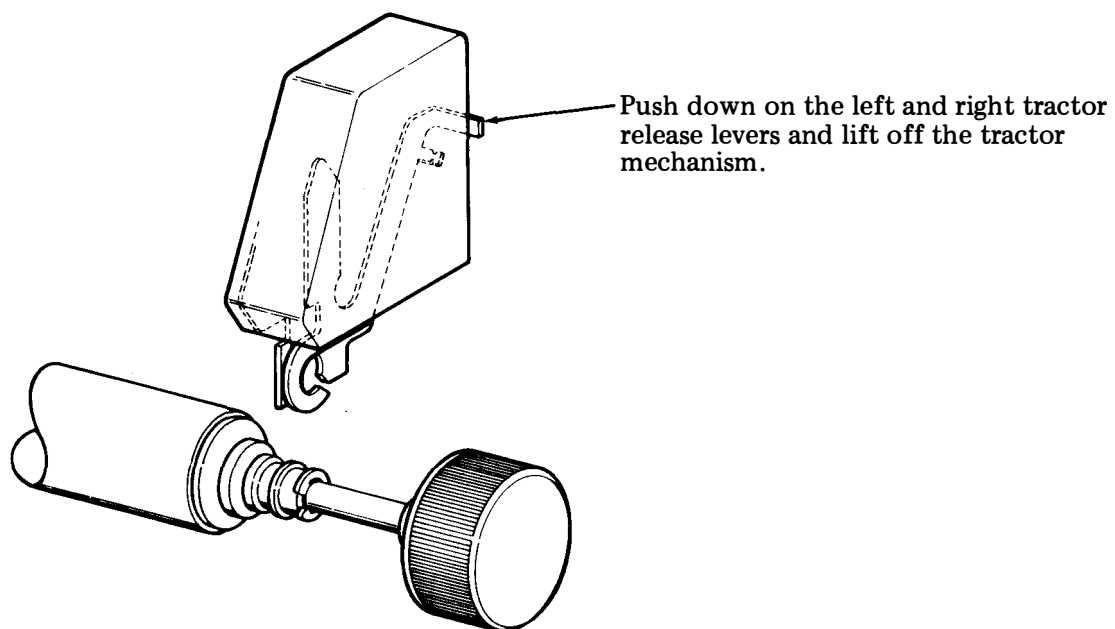

4.19 (b) To disassemble the tractor mechanism:

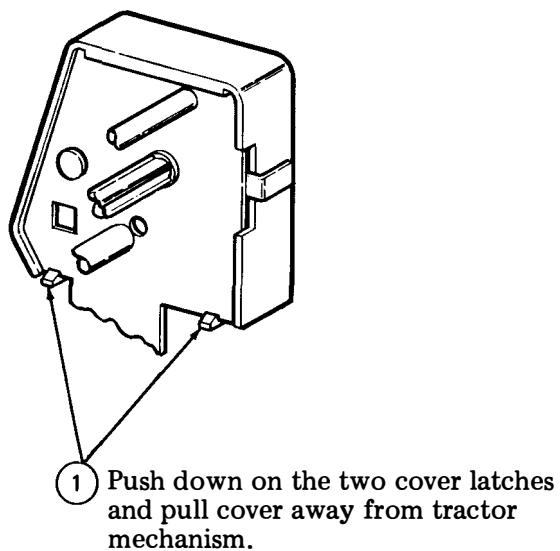



4. 15 INCH PRINTER DISASSEMBLY/REASSEMBLY (Contd)

TRACTOR MECHANISM (Contd)

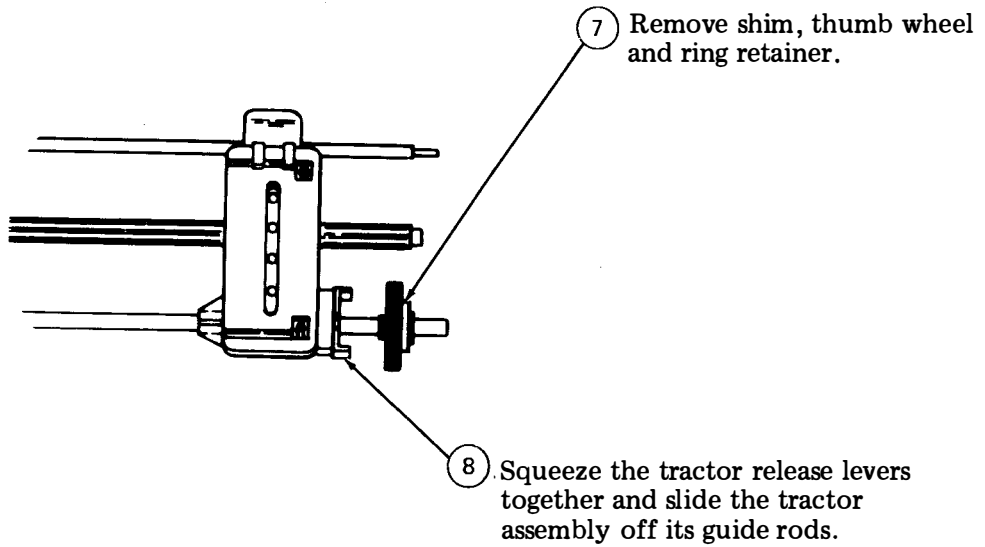
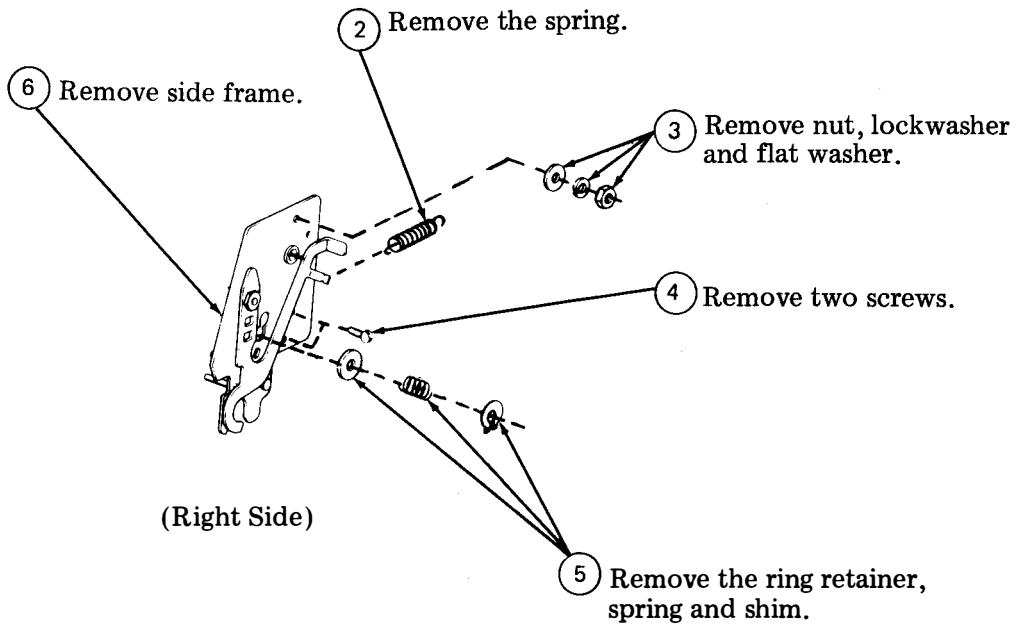

4.19 (c) To reassemble the tractor mechanism:

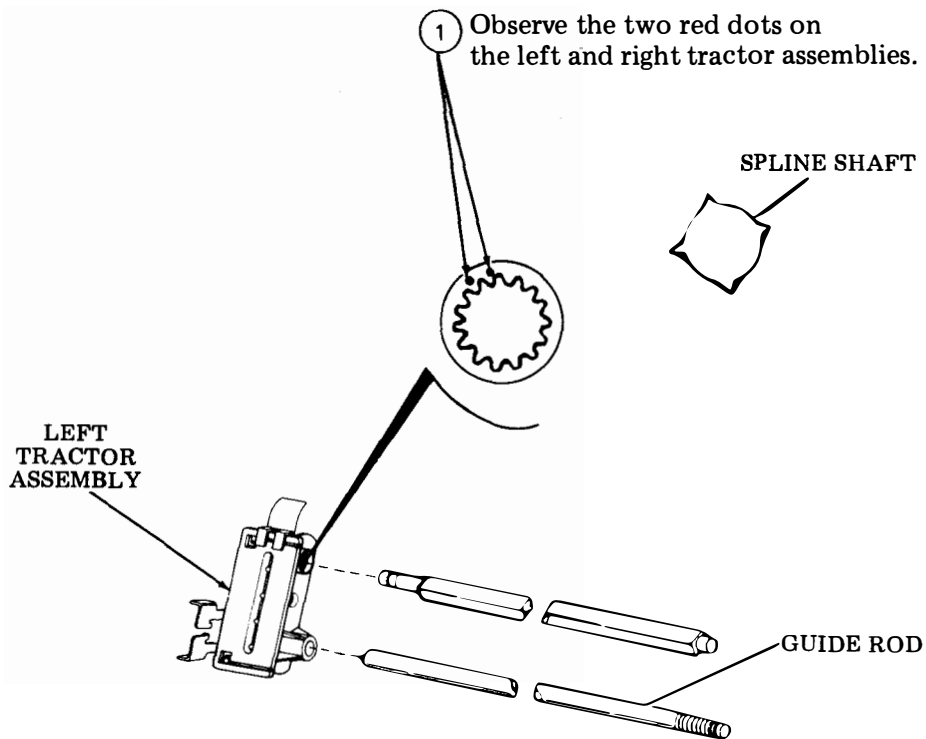

② Squeeze the tractor release levers together and slide the left tractor assembly onto the guide rod and the spline shaft. When sliding onto the spline shaft, make sure one of the splines fits into the sprocket located between the two red dots shown in ① .

③ Squeeze the tractor release levers together and slide the right tractor assembly onto the guide rod and the spline shaft. When sliding onto the spline shaft, make sure the sprocket located between the two red dots (shown in ① ) fits over the same spline as did the left tractor assembly.

④ Reassemble the remainder of the components removed in (b).

4. 15 INCH PRINTER DISASSEMBLY/REASSEMBLY (Contd)

PLATEN ASSEMBLY

4.20 (a) To remove platen assembly:

- ① Remove paper guide (perform 4.12, ①).
- ② Remove tractor mechanism (perform 4.19 (a)).

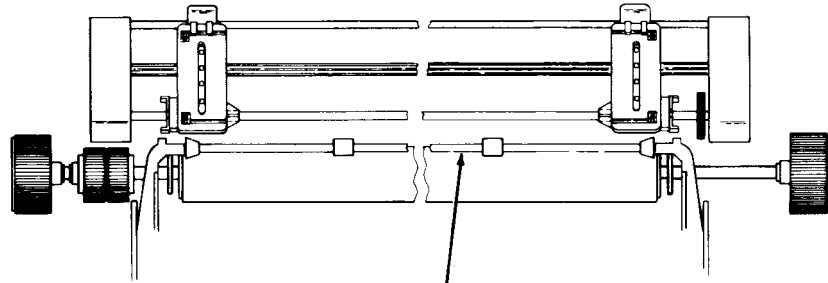

③ Pull the paper tensioner arm forward.

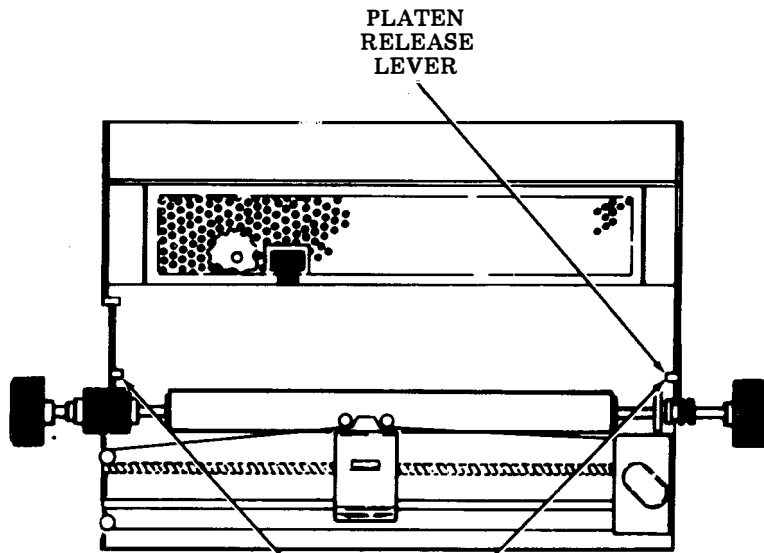

④ Remove platen by depressing left and right platen release lever and lifting out platen.

4.20 (b) To disassemble the platen:

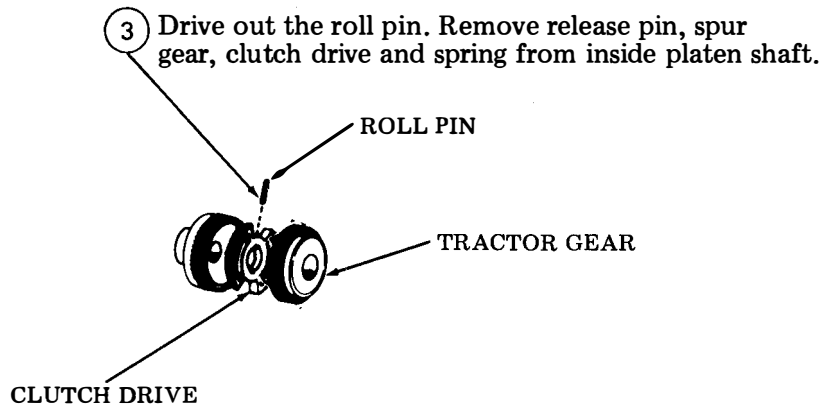
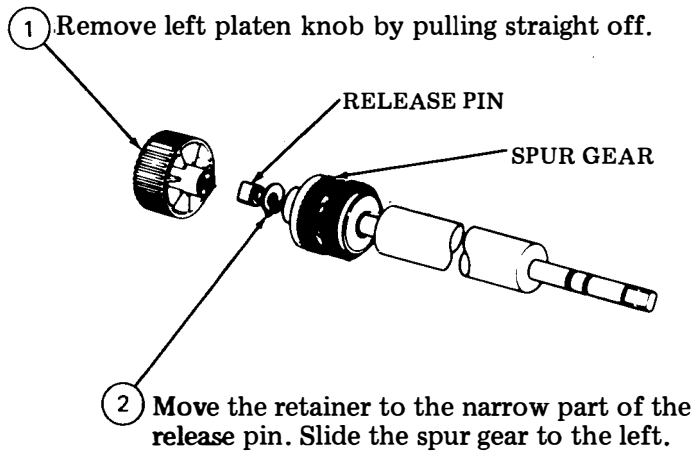

*Warning 1: In reassembly, tapered side of clutch drive faces to the left. If roll pin is damaged in removal, replace it.*

*Warning 2: If the tractor gear is removed perform the TRACTOR GEAR TO PLATEN BUSHING adjustment.*

4. 15 INCH PRINTER DISASSEMBLY/REASSEMBLY (Contd)

453165 PAPER TRAY

4.21 To remove the paper tray:

- ① Remove the platen assembly (perform 4.20 (a)).

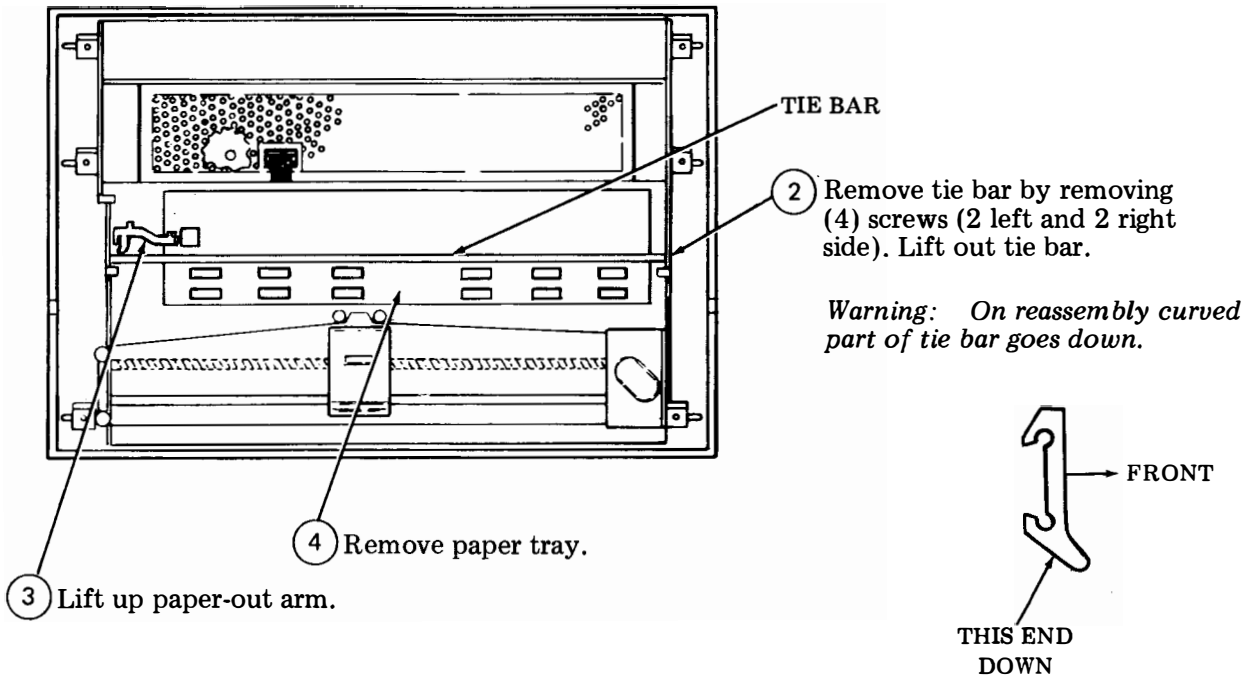

LEAD SCREW

4.22 To remove the lead screw:

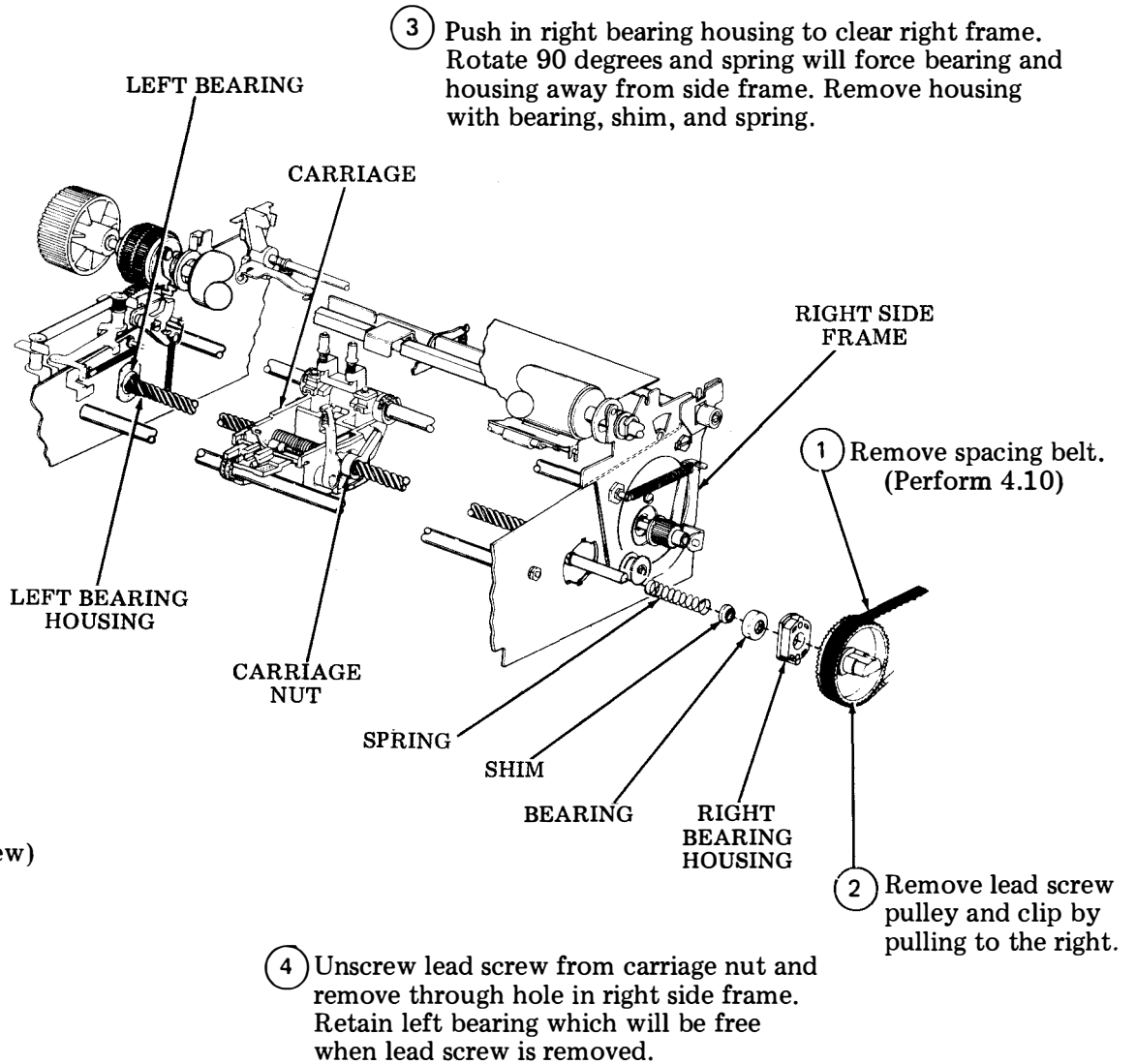

(Right Side View)

4. 15 INCH PRINTER DISASSEMBLY/REASSEMBLY (Contd)

CARRIAGE WITH POST ASSEMBLY

4.23 To remove the carriage with post assembly:

- ① Remove paper tray (perform 4.21).
- ② Remove print head and lead screw (perform 4.01 and 4.22).
- ③ Move carriage to left margin. Remove carriage cable from logic card.
- ④ Remove outer side plate bias spring (one each side).

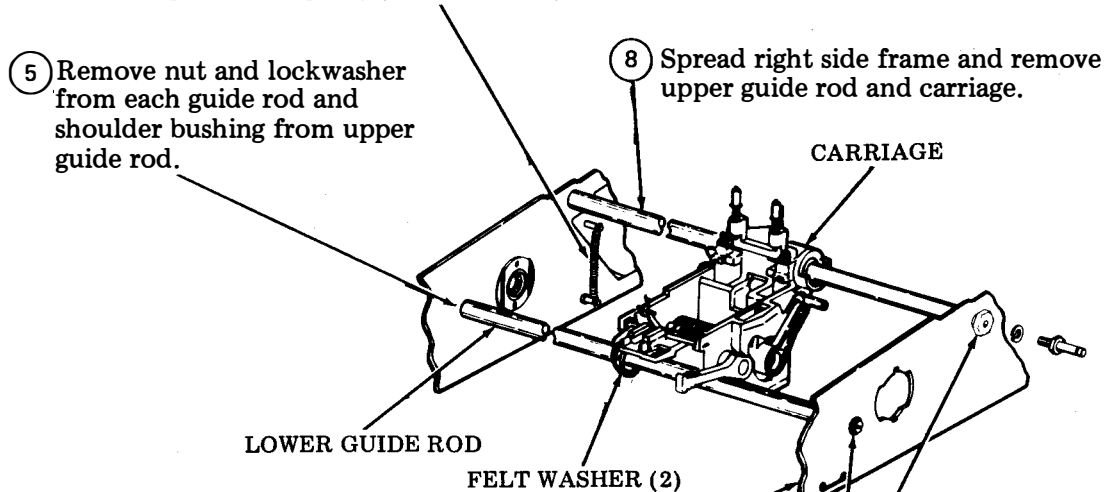

⑤ Remove nut and lockwasher from each guide rod and shoulder bushing from upper guide rod.

⑧ Spread right side frame and remove upper guide rod and carriage.

⑦ Spread right side frame outward to disengage right end of lower guide rod, then pull toward the front to remove lower guide rod and two felt washers.

⑥ Remove screw with washer from the lower guide rod and spring post, lockwasher and shoulder bushing from the upper guide rod.

LEAD SCREW NUT

4.24 To remove the lead screw nut:

- ① Remove print head and lead screw (perform 4.01 and 4.22).
- ② Tilt lead screw nut handle outward to clear retaining notch in carriage. Rotate counterclockwise (CCW) until tabs on nut align with opening in carriage. Spring will force nut away from carriage.
- ③ Remove springs and nuts.

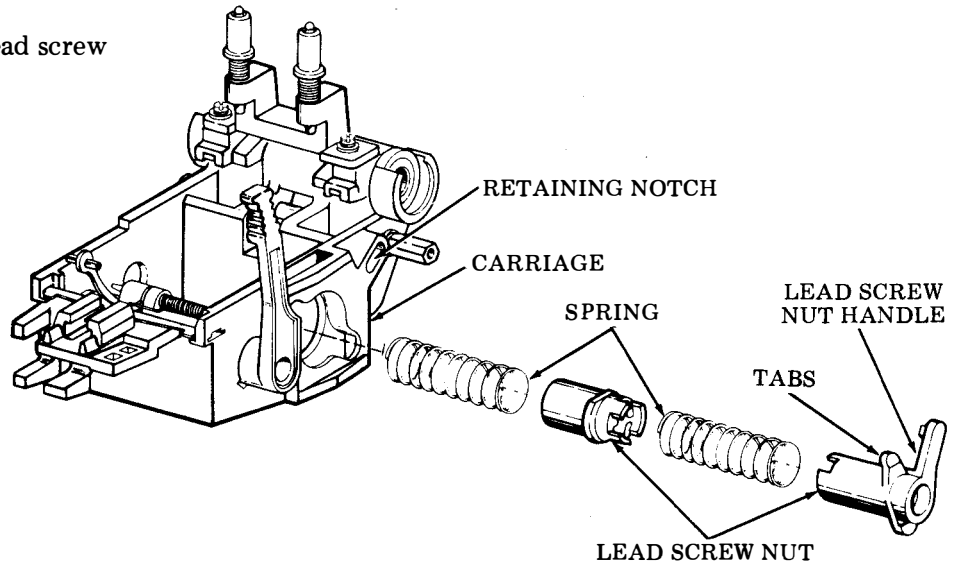

*Warning: The lead screw nuts are keyed and must be engaged when properly installed.*

COLLAR WITH LINK

4.25 To remove the collar with link:

- ① Remove print head and carriage (perform 4.01 and 4.23).

- ② Remove compression ring.

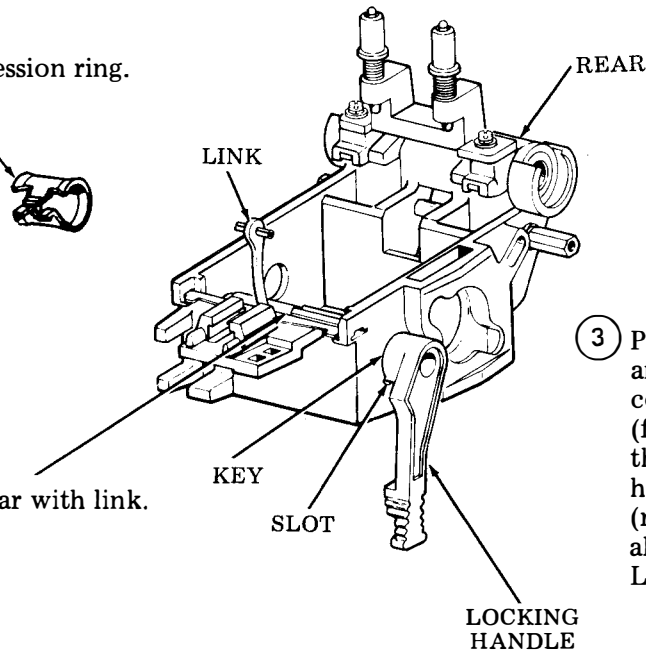

- ④ Remove collar with link.

- ③ Push locking handle to the left and rotate locking handle and collar fully counterclockwise (forward). Pull the handle to the right while slowly rotating handle and collar clockwise (rearward) until key on handle aligns with slot in carriage. Locking handle will pop out.



4. 15 INCH PRINTER DISASSEMBLY/REASSEMBLY (Contd)

PAPER DEFLECTOR SHIELD AND BRIDGE ASSEMBLY

4.26 To remove the paper deflector shield and bridge assembly:

- ① Center the print head and pull the print head locking handle away from the platen as far as it will go.
- ② Remove the ribbon if present.
- ③ Unscrew mounting screws and remove screws, lockwasher, washers, bridge assembly and paper deflector shield.

*Note 1:* To prevent the special nuts, which are keyed from falling out of their slots, insert a piece of foam rubber under the nuts such that it holds them into position. Remove foam rubber after reassembly.

*Note 2:* In reassembly, perform the PAPER DEFLECTOR SHIELD adjustment.

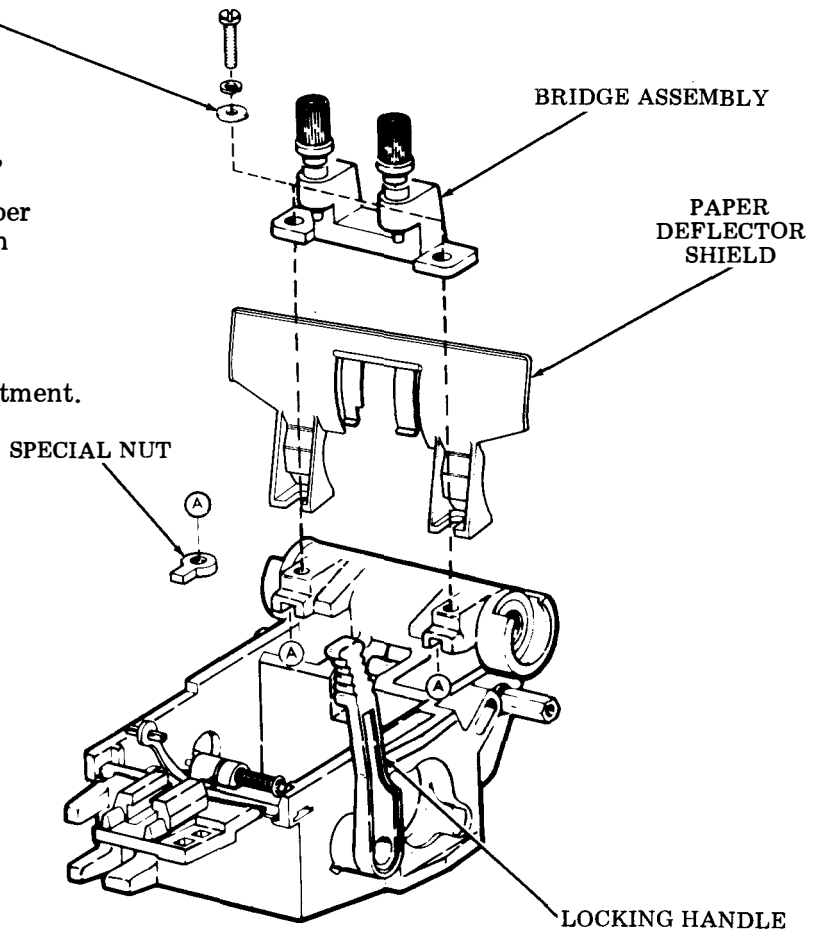

TOP OF FORM TAPE READER

4.27 To remove the top of form tape reader:

- ① Remove the rear frame and back portion of the logic card cover (perform 4.14, ① through ⑬ except ⑨).

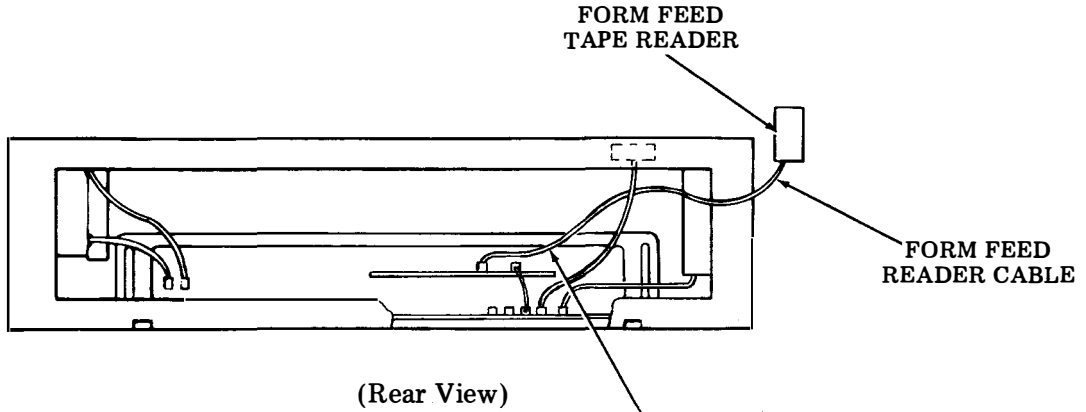

- ② Disconnect the top of form tape reader cable from the logic card.

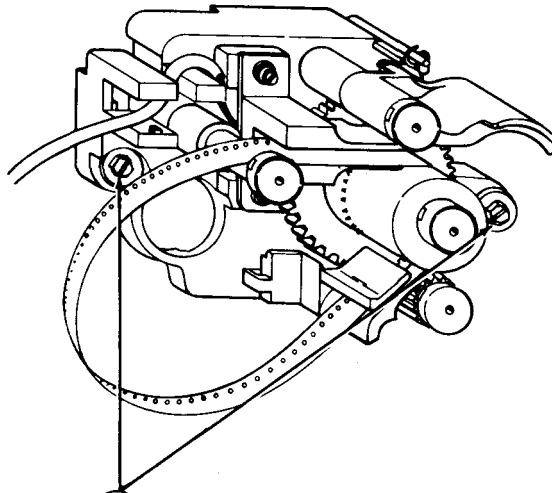

- ③ Remove two (one each side) screws, washers and lockwashers.
- ④ Remove top of form tape reader.

**Warning:** In reassembly check FORM FEED TAPE READER TO INTERMEDIATE GEAR adjustment and FORM FEED TAPE TO OPTICAL SWITCH ASSEMBLY adjustment.

PART 4 — ADJUSTMENTS AND SPRING TENSIONS

<u>CONTENTS</u>	<u>PAGE</u>	<u>CONTENTS</u>	<u>PAGE</u>
A. GENERAL .....	4-2	D. 12 INCH TRACTOR	
B. TOOLS REQUIRED .....	4-2	FEED PRINTER.....	4-14
C. 12 INCH FRICTION AND SPROCKET		1. PRINTER ADJUSTMENTS .....	4-14
(PIN) FEED PRINTER.....	4-3	Print head to platen.....	4-14
1. PRINTER ADJUSTMENTS .....	4-3	Ribbon cartridge magentic latch ..	4-14
Left paper sprocket (sprocket		Pressure roller bail.....	4-15
feed only) (early design) .....	4-3	Paper alarm contact lever .....	4-16
Right paper sprocket (sprocket		Platen endplay.....	4-16
feed only) (early design) .....	4-3	Printed line position .....	4-17
Left and right paper guides		Print head armature.....	4-17
(horizontal positioning) (sprocket		Line feed motor gear-backlash....	4-18
feed only) (early design) .....	4-3	Idler gear and platen gear .....	4-18
Left and right paper guides		Tractor idler gear backlash .....	4-19
(angular positioning) (sprocket		Tractor idler gear to platen gear ..	4-20
feed only) (early design) .....	4-4	2. SPRING TENSIONS.....	4-21
Left and right paper guides		3. SPRING IDENTIFICATION.....	4-22
(angular positioning) (friction feed		E. 15 INCH TRACTOR	
and late design sprocket feed)....	4-4	FEED PRINTER.....	4-23
Line feed belt tension		1. PRINTER ADJUSTMENTS .....	4-23
(sprocket feed only) .....	4-4	Line feed motor gear backlash....	4-23
Line feed motor belt tension		Idler gear to platen gear.....	4-24
(floating motor only) .....	4-5	Platen gear to platen bushing.....	4-24
Print head to platen.....	4-6	Square shaft support bracket.....	4-25
Ribbon cartridge magentic latch ..	4-7	Platen to print head gap .....	4-25
Line feed follower		Paper-out switch .....	4-26
pulley stop bracket .....	4-7	Ribbon cartridge to magnet.....	4-26
Pressure roller bail		Paper deflector shield .....	4-27
(friction feed only) .....	4-8	Eccentric bushing .....	4-27
Paper guide plate clearance		Tractor idler gear backlash .....	4-28
(sprocket feed only) .....	4-9	Tractor idler gear to platen gear ..	4-28
Paper alarm contact lever		Horizontal line alignment .....	4-29
(sprocket feed only) .....	4-9	Print head armature.....	4-30
Platen endplay and		Form feed tape reader to	
printed line position .....	4-10	intermediate gear.....	4-31
Print head armature.....	4-11	Form feed tape to optical	
2. SPRING TENSIONS.....	4-11	switch assembly.....	4-32
3. SPRING IDENTIFICATION.....	4-13	2. SPRING TENSIONS.....	4-33
		3. SPRING IDENTIFICATION.....	4-34

### A. GENERAL

This part provides adjustments and spring tensions for the 12 inch friction, sprocket (pin) feed and tractor feed printer mechanisms, and the 15 inch tractor feed printer mechanisms.

Belt tensions are checked with a spring scale held at the angle shown in the adjustment illustration.

After an adjustment is complete, tighten any screws or nuts loosened to make the adjustment.

Reference in the procedure to left or right, up or down, and top or bottom, etc, refer to the printer in its normal operating position as viewed by the operator from the front.

Adjustments should be checked and performed when a trouble indicates a specific adjustment may be out of tolerance or when an adjustment is disturbed to enable a part to be removed or replaced.

Spring tension checks should be performed when a trouble indicates a possible defective spring or to verify proper part numbers.

Springs that do not meet the tension requirements should be replaced.

*Note:* When ordering replaceable parts or components, unless otherwise specified, prefix each part number with the letters "TP" (ie, TP410055).

### B. TOOLS REQUIRED

The following tools may be required when performing adjustments or spring tension checks. Most of these items should normally be present in standard maintenance tool kits.

<u>Part No.</u>	<u>Description</u>
75765	Hook, Pull Spring
82711	Scale, Spring (64 ounce)
94647	Screwdriver, 3-1/2 Inch Blade
95368	Screwdriver
100982	Screwdriver With Clip
110443	Scale, Spring (8 ounce)
110444	Scale, Spring (32 ounce)
117781	Gauge Set
124682	Wrench, Hex Key
125752	Wrench, 3/16 Inch Socket
129534	Wrench, 3/16 Inch and 1/4 Inch Open End
135059	Scale, 15 Pound Spring
142554	Hook, Pull Spring
142555	Hook, Push Spring
151392	Tweezers
152835	Wrench, 5/16 Inch and 3/8 Inch Open End
348097	Nut Driver, 1/4 Inch
348098	Nut Driver, 5/16 Inch

C. 12 INCH FRICTION AND SPROCKET (PIN) FEED PRINTER

1. PRINTER ADJUSTMENTS

LEFT PAPER SPROCKET (Sprocket Feed Only)  
(Early Design)

Requirement

The left sprocket should be biased against the collar of the platen hub.

To Adjust

Loosen set screws and position left sprocket to meet requirement.

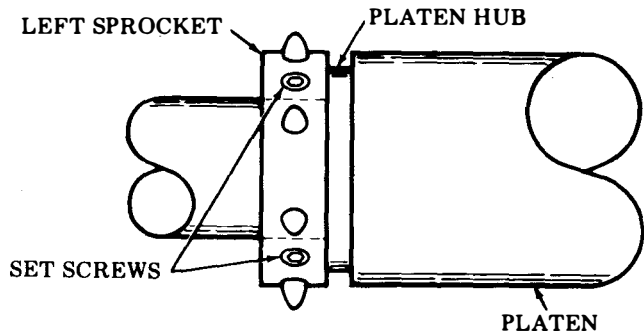

RIGHT PAPER SPROCKET (Sprocket Feed Only)  
(Early Design)

Requirement

The right sprocket should be biased against the collar of the platen hub and the pins should be in line with the pins of the left sprocket.

To Adjust

Loosen set screws and position right sprocket to meet requirement.

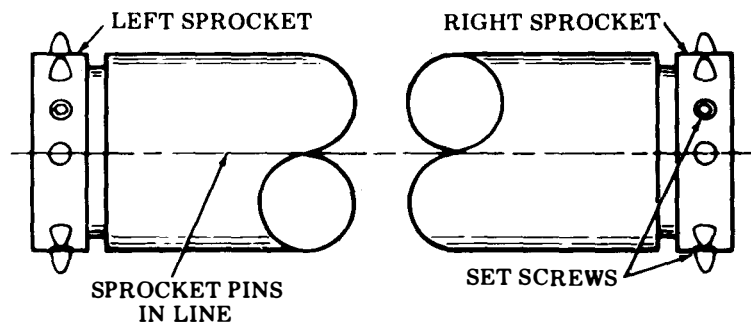

*Note:* This adjustment to be refined when making the PRINTED LINE POSITION adjustment.

LEFT AND RIGHT PAPER GUIDES  
(Horizontal Positioning) (Sprocket Feed Only)  
(Early Design)

*Note:* Late design brackets do not require this paper guide adjustment.

Requirement

There should be some clearance between the base of the sprocket pins and either side of the paper guide slot.

To Adjust

Loosen screws friction tight and position paper guide bracket by using a screwdriver on the pry points.

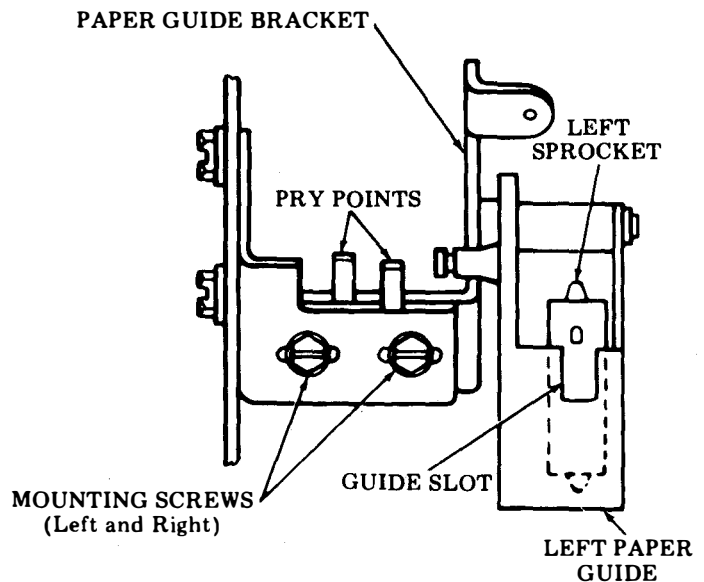

## C. 12 INCH FRICTION AND SPROCKET (PIN) FEED PRINTER (Contd)

### 1. PRINTER ADJUSTMENTS (Contd)

#### LEFT AND RIGHT PAPER GUIDES (Angular Positioning) (Sprocket Feed Only) (Early Design)

##### Requirement

The paper guides should seat fully on the paper sprockets (left and right sides).

##### To Adjust

Loosen screws. To seat the paper guides, apply finger pressure to top of paper guides at 45 degrees and toward center of platen. With finger pressure applied at approximately 45 degrees; tighten screws.

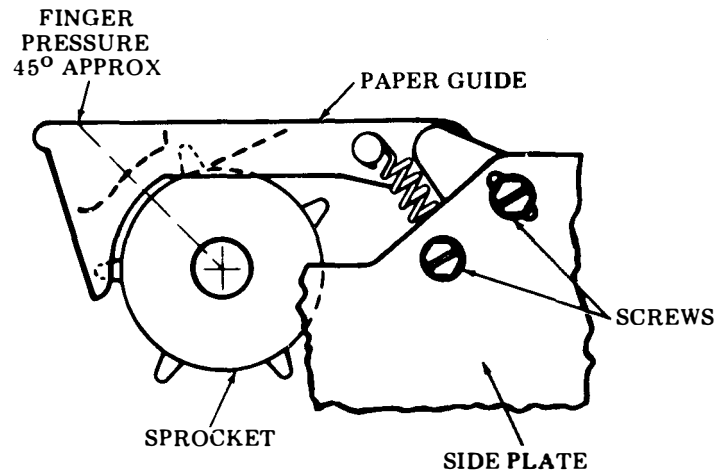

#### LEFT AND RIGHT PAPER GUIDES (Angular Positioning) (Friction Feed and Late Design Sprocket Feed)

##### Requirement

The left paper guide should seat fully on the hub. The right paper guide should also be fully seated on the hub and the center paper guide should just touch the platen in the middle.

##### To Adjust

On left side, loosen the two mounting screws friction tight and move the left paper guide mounting bracket to meet the adjustment. With finger pressure applied, tighten screws.

On right side, loosen one mounting screw and with an open end wrench applied to the hex post, rotate bracket until adjustment is met. While holding the post, retighten the screw.

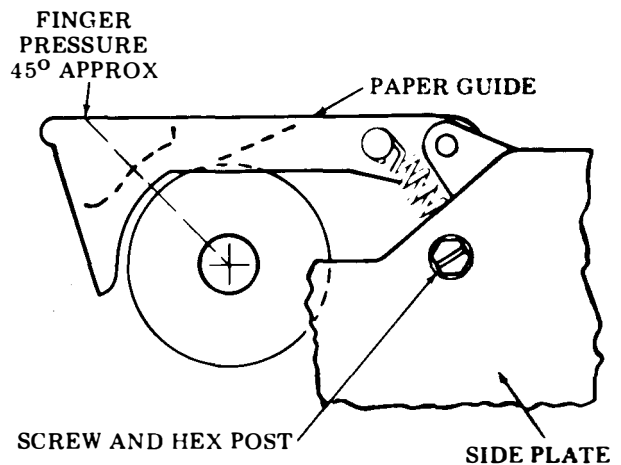

#### LINE FEED BELT TENSION (Sprocket Feed Only)

*Note:* This adjustment applies to Sprocket Feed (Early Design) only, without follower pulley.

##### Requirement

When the belt and sprocket system is at the point of least slack; a force of 5 ounces applied with a spring scale midway between the sprockets the belt should deflect between

Min 0.090 inch---Max 0.120 inch

The point of least slack is the point where the set screws on the platen pulley and those on the motor pulley are set as shown below.

##### To Adjust

Rotate the platen until the set screws on the platen pulley and the set screws on the motor pulley are aligned as shown below. Loosen motor screws, position motor to meet requirement at the point of least slack. Tighten screws.

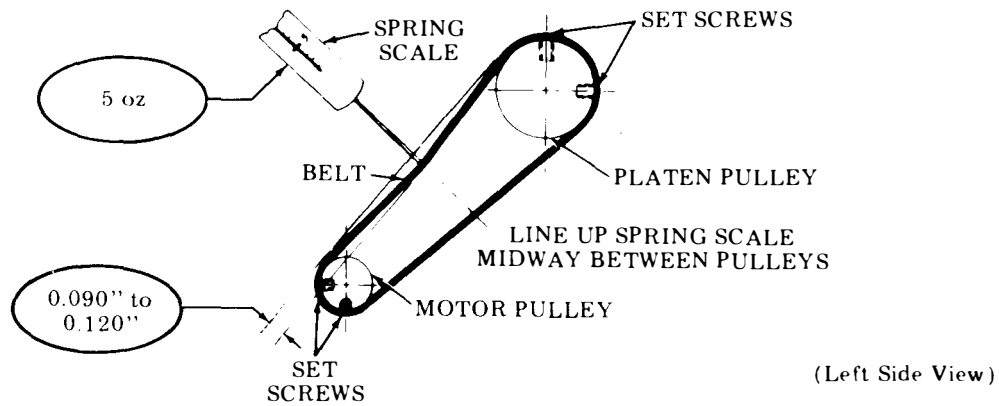

**LINE FEED MOTOR BELT TENSION (Floating Motor Only)**

**Requirement:**

When the belt and sprocket system is at the point of maximum tension as shown (pulley screws facing out), there shall be some clearance between the top of the spacer and the top of the slot. Check by squeezing belt while observing upward motor movement.

When the pulleys are at the point of minimum tension (pulley screws facing in), the distance across the belt shall be a minimum of 5/8 inch with the belt deflected until the motor rises to the top of its free travel (spacer at top of slot).

**To Adjust:**

With the system pulleys set up for minimum tension and the clamping screw loose, press down on the motor to reduce any belt slack, then release. Hold spacer down and tighten screw.

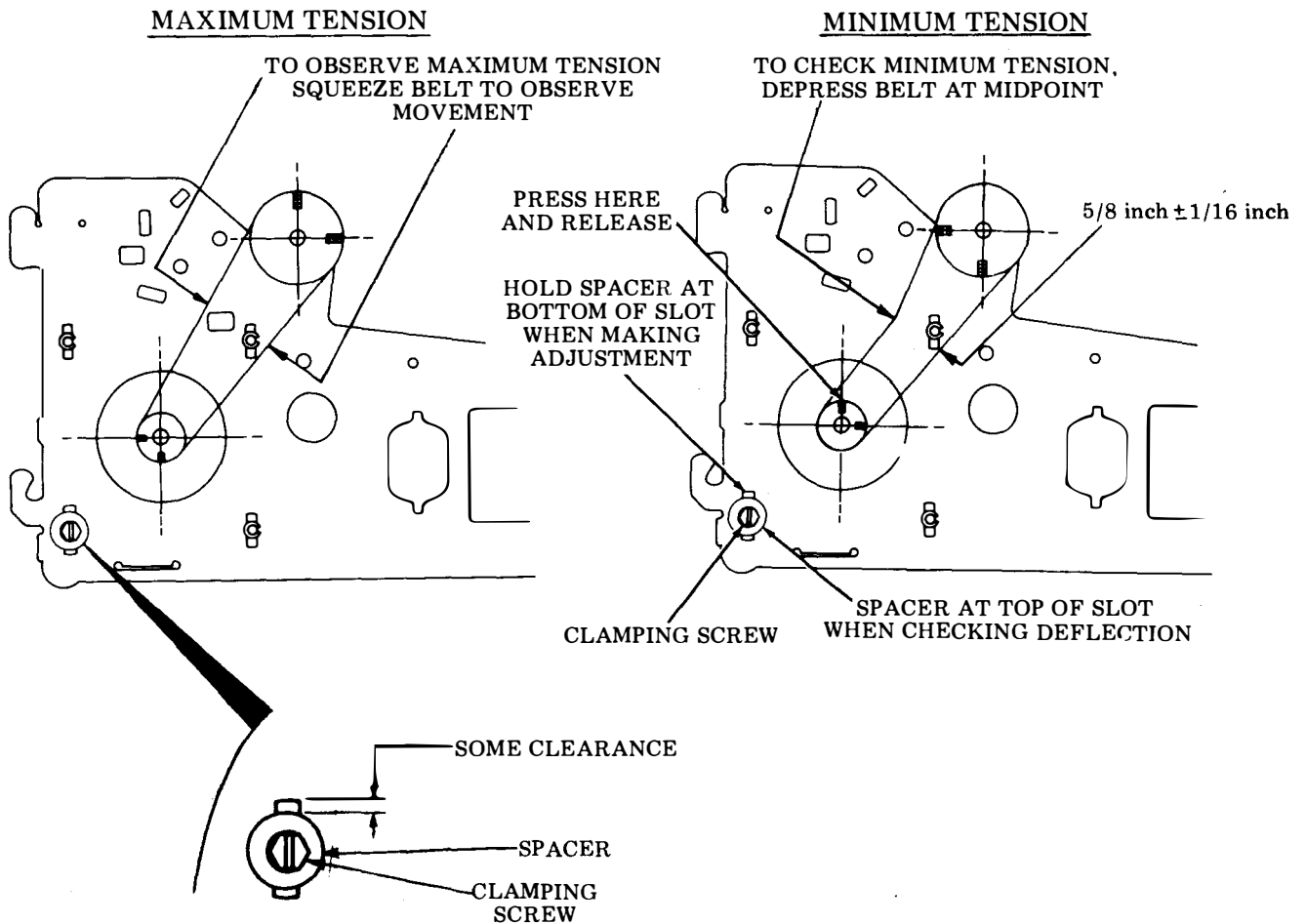

C. 12 INCH FRICTION AND SPROCKET (PIN) FEED PRINTER (Contd)

1. PRINTER ADJUSTMENTS (Contd)

PRINT HEAD TO PLATEN

Requirement

There should be

Min 0.025 inch---Max 0.035 inch

gap between the ribbon guide of the print head and the platen (without paper or ribbon) and at all positions of the carriage and platen, when platen play at the right end is biased down and to the rear and the print head is locked.

To Adjust

Position carriage to the extreme left position. Unlock locking handle, use 1/4 inch "J" wrench to loosen right-hand locknut and with carriage biased rearward, insert 1/4 inch socket wrench through access hole in left side frame and rotate eccentric post to adjust. Tighten locknut. Check adjustment with carriage locked. Check adjustment on extreme right end of platen, while biasing platen down and to the rear. Refine adjustment, if necessary.

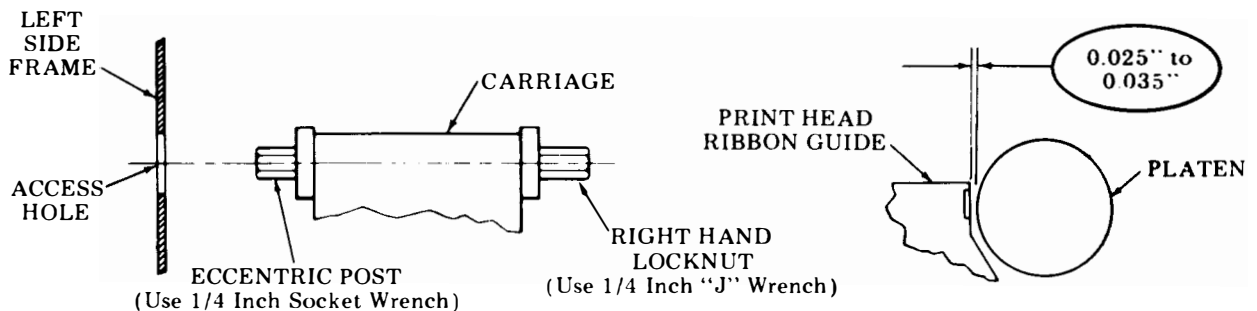



**RIBBON CARTRIDGE MAGNETIC LATCH**

**Requirement**

The magnetic pole pieces of the magnetic latch should be firmly engaged with the cartridge lower metal plate when the cartridge is installed in the right-hand cartridge mounting bracket.

**To Adjust**

Loosen the two magnetic latch mounting screws. Install cartridge onto the mounting bracket. While holding the cartridge down firmly, allow the magnetic latch to fully engage the lower metal plate of the cartridge. Tighten the latch mounting screws.

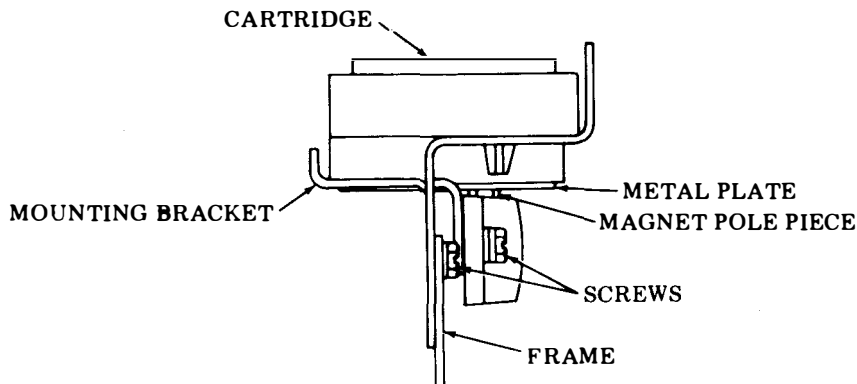

**LINE FEED FOLLOWER PULLEY STOP BRACKET**

*Note:* For units with line feed pulleys only.

**Requirement**

With the set screws on both pulleys positioned as shown below and with the follower pulley resting on the belt, push the pulley against the belt to take up all friction. Slowly release pressure. Measuring between the follower lever and the adjacent tab of the stop bracket there should be

Min 0.010 inch--Max 0.050 inch gap between them.

**To Adjust**

Loosen the two mounting screws on the stop bracket to friction tight and move bracket to meet the adjustment. If the motor mounting holes are slotted, the motor may be repositioned from the center of the slot, if necessary, if the stop bracket adjustment does not meet the requirement.

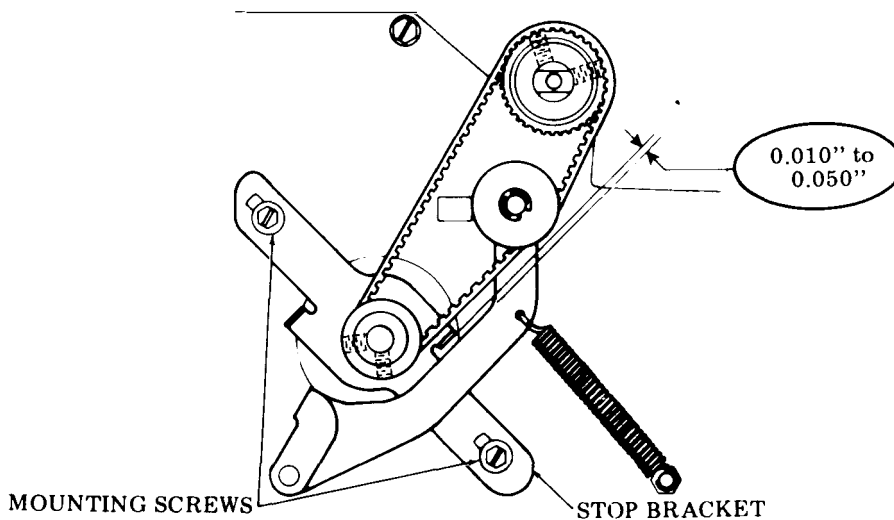

C. 12 INCH FRICTION AND SPROCKET (PIN) FEED PRINTER (Contd)

1. PRINTER ADJUSTMENTS (Contd)

PRESSURE ROLLER BAIL (Friction Feed Only)

**Requirement**

With the paper release lever in the forward position and the right end of the carriage next to the right rear carriage wick located immediately under the arm of the pressure roller bail (between the two pressure rollers) there should be from

Min 0.050 inch---Max 0.080 inch  
gap between the carriage and the bail arm when measured at the closest point.

**To Adjust**

Loosen the clamp screw to friction tight. Move pry point down to increase gap or up to decrease gap.

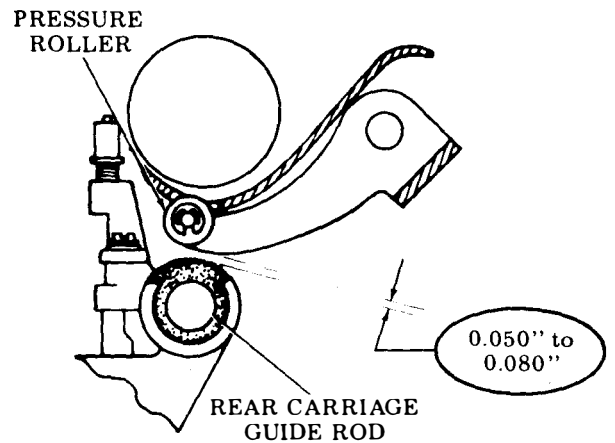
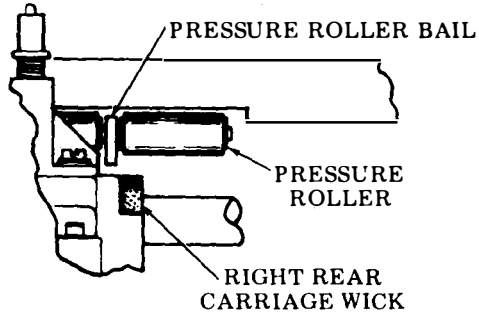

(Right Side View)

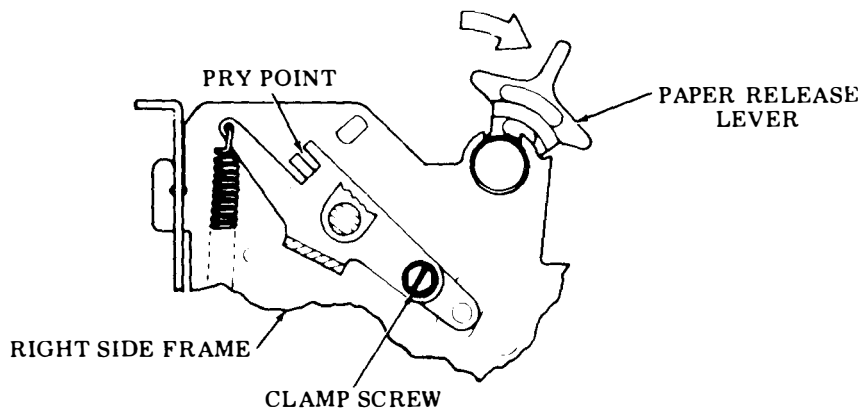

PAPER GUIDE PLATE CLEARANCE (Sprocket Feed Only)

*Note:* For sprocket feed (Early Design) with metal paper guide only.

(1) Requirement

With no sprocket forms in the platen mechanism and the platen oriented with the slot, or rib, on the right platen hub in the top uppermost position there should be

Min 0.008 inch---Max 0.025 inch between the platen and the left and right ends of the paper guideplate. Record the two clearances.

To Adjust

Loosen locknut and adjust screw. Tighten locknut.

(2) Requirement

The fingers at both the left and right ends of the platen should be

Min Some---Max 0.015 inch beyond the recorded gap between the platen and the left and right ends of the paper guideplate.

To Adjust

Bend fingers to meet requirement.

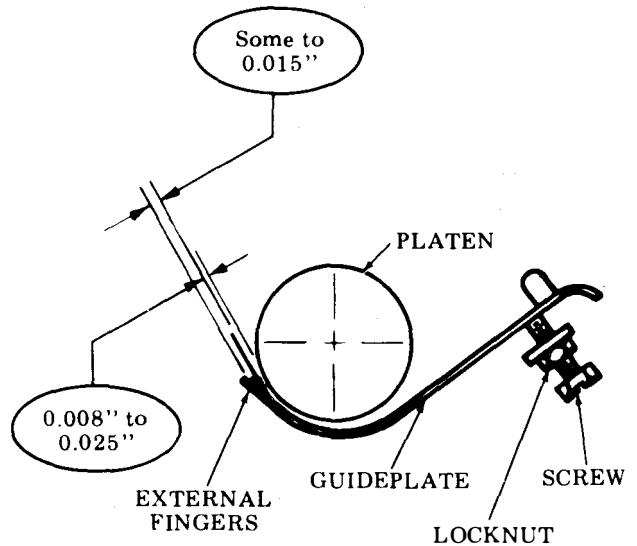

PAPER ALARM CONTACT LEVER (Sprocket Feed Only)

Requirement

With the paper alarm contact lever resting on the paper and the paper held taut over the cutout in the paper guide tray, the switch will be in the off mode (nonalarm). With the paper out, the lever should activate the switch (alarm mode).

To Adjust

Loosen screws and position switch bracket to meet requirement.

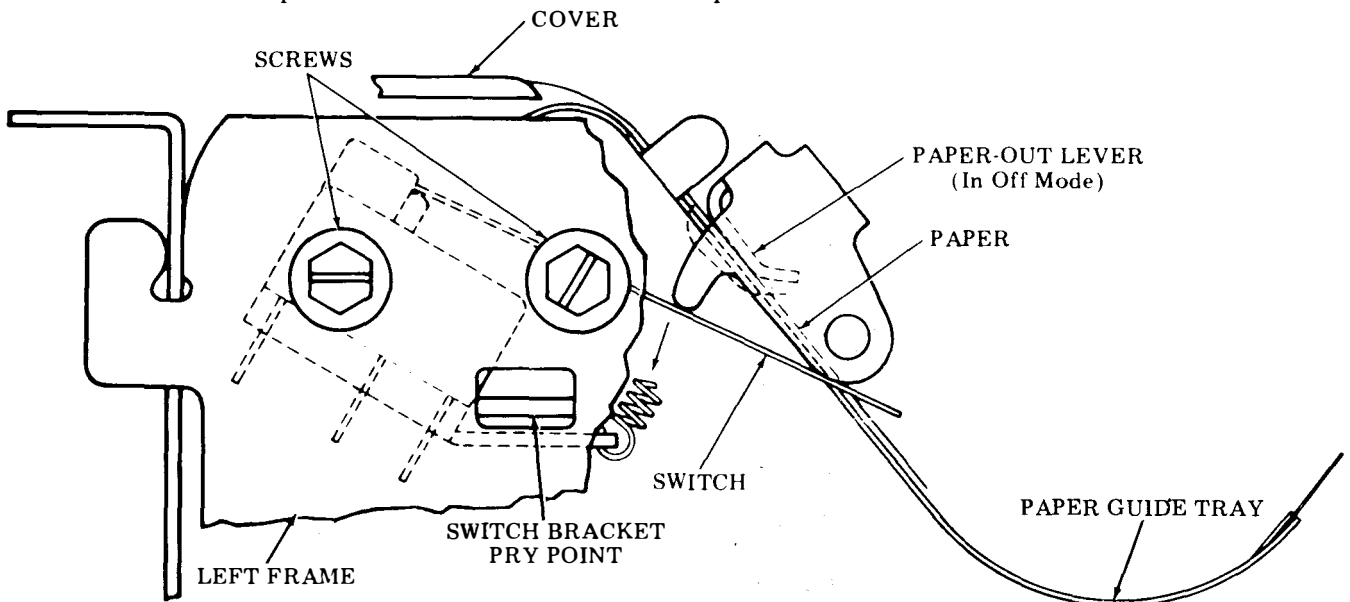

(Left Side View)