

**INSTRUCTIONS FOR INSTALLING THE 184157 MODIFICATION
KIT ON MODEL 32/33 FRICTION-FEED TYPING UNITS TO
PROVIDE AUTOMATIC LINE FEED ON CARRIAGE RETURN**

1. GENERAL

a. The 184157 modification kit provides automatic line feed on the type-
ing unit when the carriage return key is depressed.

b. The extended tab on the 183499 blocking lever rides the 180793 car-
riage return function lever. Upon receiving the carriage return code com-
bination, the carriage return lever moves upward to its selected position
carrying the 183499 lever with it. As the 183499 lever rises, it engages
the latching surface on the 181500 line feed drive link. During the middle
portion of the cycle, the carriage return lever and the line feed drive link
are driven downward causing both functions to occur simultaneously.

c. It should be noted that this modification kit will give "Line Feed"
on "Carriage Return" whereas other machines give "Carriage Return" on "Line
Feed." This will result in machines equipped with this modification kit per-
forming double line feeds if it receives a message containing the standard
CR-LF end-of-line code sequence, and triple line feed if it receives CR-CR-LF
end-of-line sequence. To obtain carriage return on line feed, order Modi-
fication Kit 185983.

d. The 184157 modification kit is for use on friction-feed units only and
consists of the following parts:

- 1 183499 Lever, Blocking
- 1 101386 Spring

2. INSTALLATION (Figures 1 and 2)

a. Remove the printer assembly from the sub-base.

b. If the printer is not equipped with a perforator, proceed to Paragraph

2. c. If it has a perforator, perform the following steps:

(1) To aid in reassembly, measure and record the gap for the Tape
Punch Drive Adjustment. See Section 574-125-700, Bulletin 273B.

(2) If the perforator has a die cast frame (early design), remove it
from the printer per Section 574-125-702, Bulletin 273B, and then proceed to

Paragraph 2. b. (3). If the perforator has a stamped sheet metal frame with adjustable mounting brackets (late design), remove (2) 181243 screws from 182805 nutplate, 181242 screw from 182252 post, 182252 post from 181045 post, and then proceed to Paragraph 2. b. (3).

NOTE

Do not loosen (2) 181241 screws fastening 182253 bracket to 182254 bracket.

(3) Remove the tape punch drive assembly from the function rocket shaft per Section 574-125-702, Bulletin 273B.

- c. Turn the printer onto its left side.
- d. Unhook 84226 spring from 181500 link.
- e. Unhook 7655 spring from 181179 blocking lever and 181503 guide bracket.
- f. Remove (2) 181240 screws holding 181503 guide bracket to 180769 left link w/stud. Remove 181503 from the unit.
- g. Place printer upright and loosen three(3) clamp screws so that 180782 shaft can rotate freely.
- h. Unhook 101386 spring from 180794 line feed function lever and allow the function lever and 181179 line feed blocking lever to drop.
- i. Apply slight upward pressure to 181179 line feed blocking lever at a point just in rear of the shaft.
- j. Rotate flat side of 180782 shaft toward the front of the printer very slowly until the line feed blocking lever lifts off.

CAUTION

Rotate shaft no further than necessary. If the shaft is rotated too far, other function levers will come off. In this event it will be necessary to remove the springs from all function levers and reposition them on the 180782 shaft to original position.

k. Remove 181179 line feed blocking lever and replace with 183499 blocking lever.

l. Place the open slot of 183499 blocking lever over 180782 shaft maintaining a slight downward pressure while rotating the shaft toward the front of the unit until the blocking lever falls into place.

m. Rotate 180782 shaft back to original position and tighten the three (3) clamp screws. Make sure that 180795 clamp is properly positioned.

n. Make sure that the 183499 blocking lever and the 180794 line feed function lever are in such a position that the sensing tab of the blocking lever is on top of the line feed function lever. Replace 101386 spring making certain the 180794 line feed function lever is located in the proper guide slots. Remove 91120 spring from 180793 function lever (slot 2) and discard the spring. Replace with 101386 spring.

o. Place printer on left hand side and install 181503 guide bracket, 181240 screws (2) and 7655 spring.

p. Perform the Line Feed Drive Arm Adjustment (See Bulletin 273B, Page 4-66) (Requirement: some to 0.010") except use the "carriage return" code combination (1, 3, 4, 8 marking) instead of "line feed". Note and record gap.

q. Check the Line Feed Drive Adjustment using the "line feed" code combination as specified. Note and record gap. It should be noted that the gaps recorded in these two steps will probably not be alike due to part variations.

r. Perform the Line Feed Upstop Bracket (See Bulletin 273B Page 4-66) (Requirement: 0.020" to 0.040") except use the code combination which gave the largest of the recorded gaps from the previous two steps. (Example: From Paragraph 2. p. gap was 0.008", From Paragraph 2. q. gap was zero - use "carriage return" code combination.)

s. If it was necessary to remove a perforator during an installation, re-assemble the perforator to the printer and adjust the tape punch drive mechanism so that the gap between the tape nudger and the roller is the same as the gap measured in Paragraph 2. b. (1). Check also the other perforator adjustments located in Section 574-125-700 of Bulletin 273B.

t. Replace printer on sub-base.

3. ADJUSTMENTS AND LUBRICATION

a. For standard adjustments and lubrication procedure refer to Teletype Bulletin 273B. (Bell System refer to the standardized information.)

b. Check and remake the line feed drive arm and line feed upstop bracket adjustments given in Teletype Bulletin 273B.

*

*

*

50413S

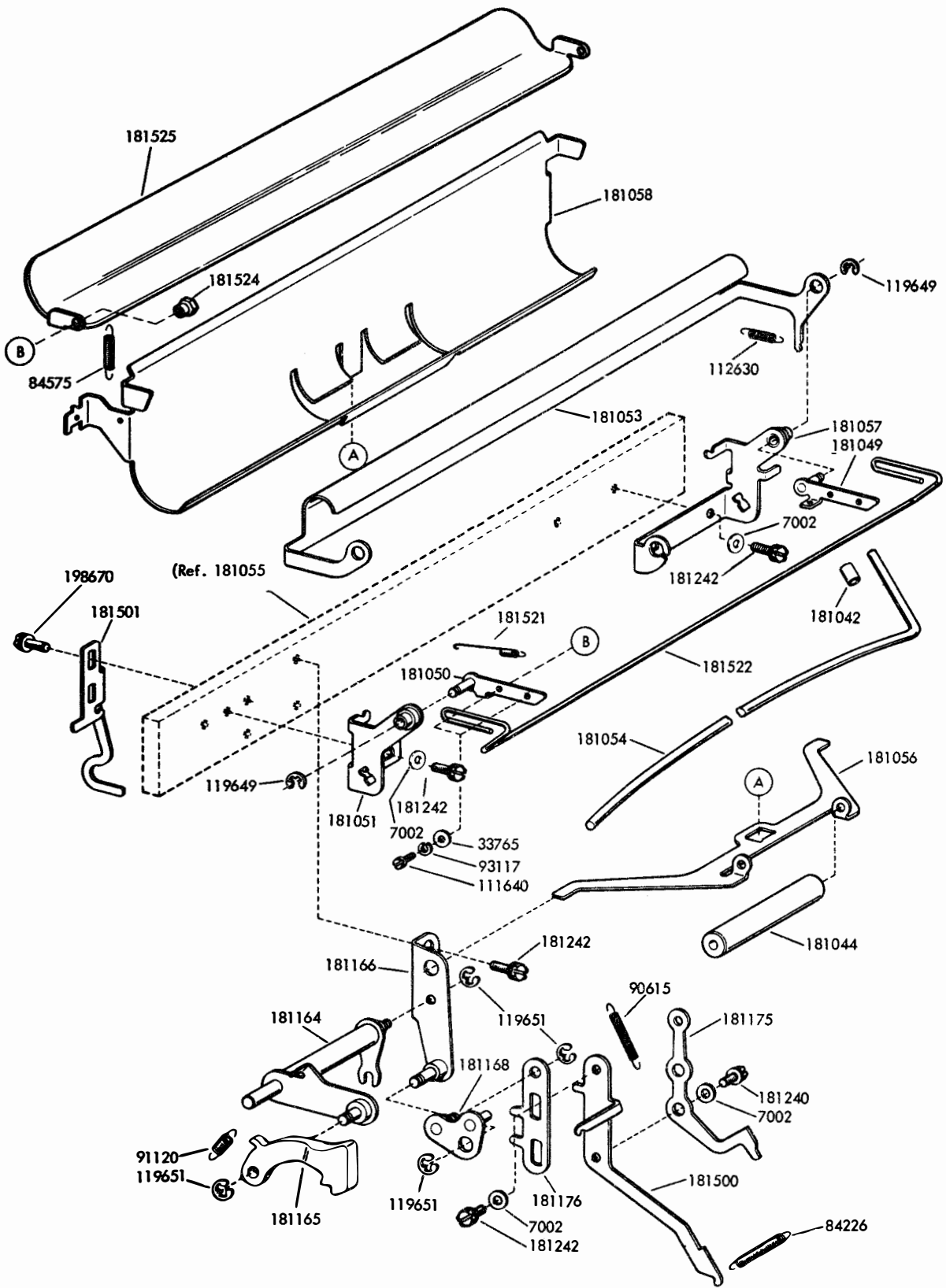

FIGURE 1

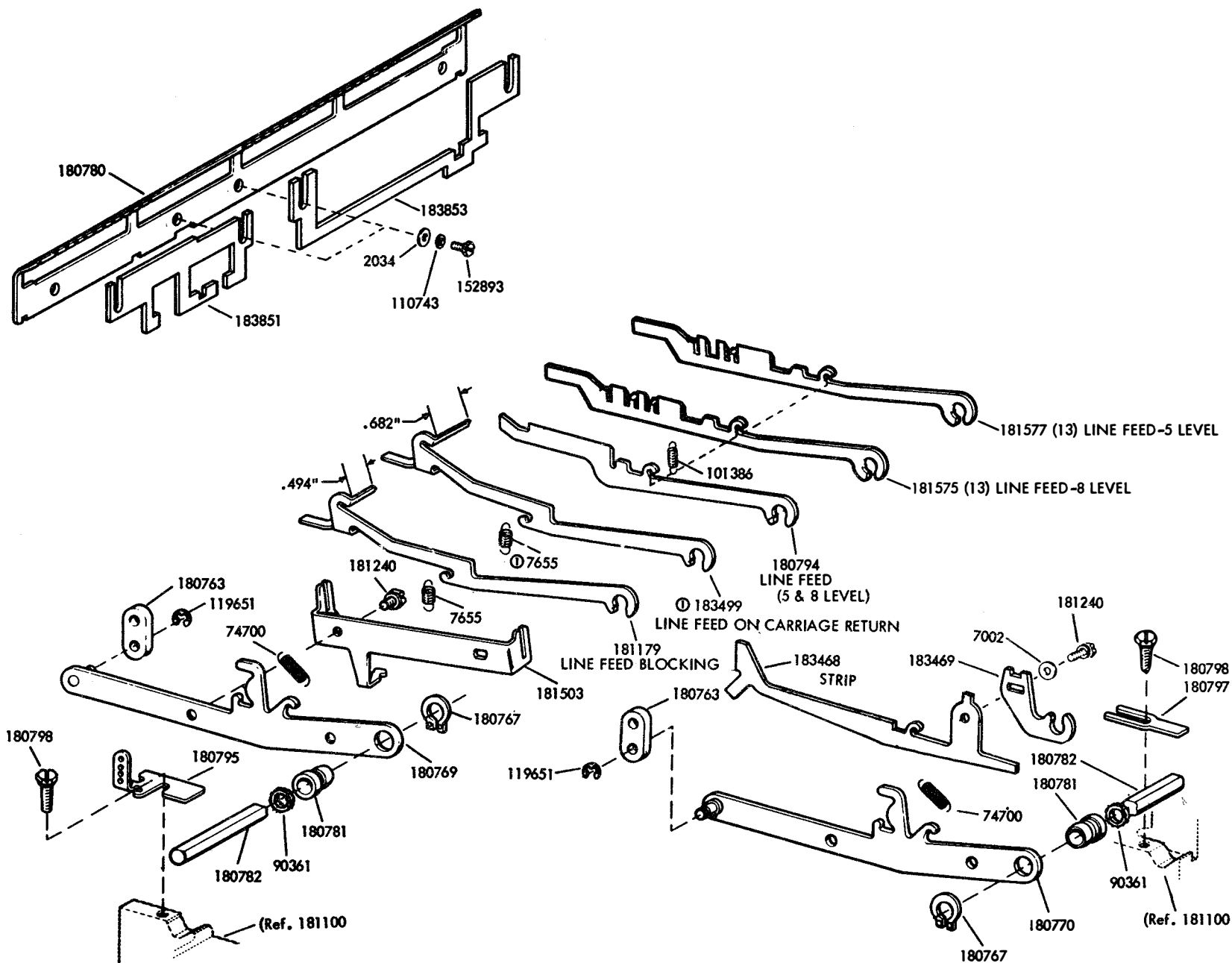

FIGURE 2

① 184157 Modification Kit to provide LF on CR
 Numbers in parenthesis () indicate slot number.

