

NAVSHIPS 94200.4 Directory of Electronics
Test Equipment
Section 4.5 Field Intensity Measuring
Equipment

NOISE MEASURING SET

AN/PQM-1

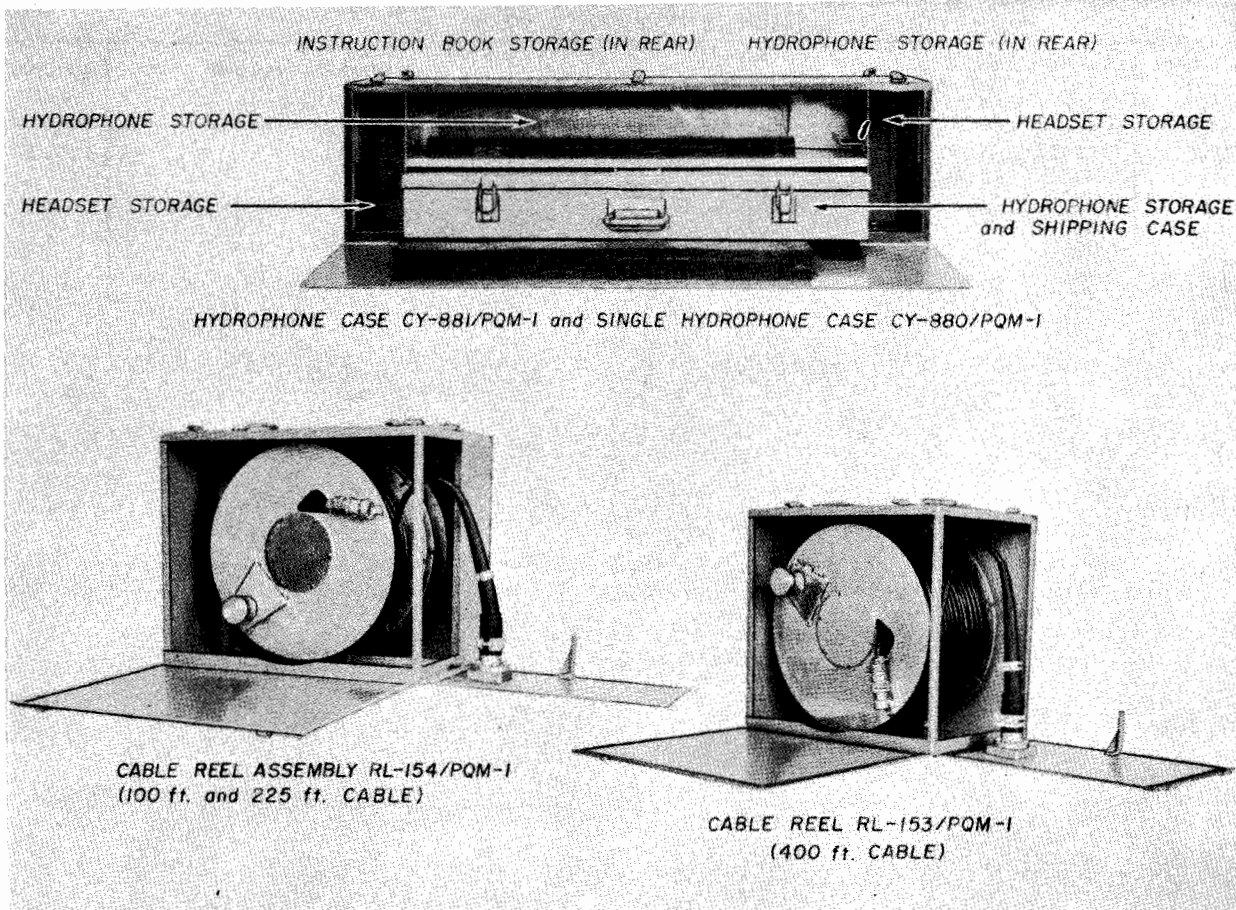

Noise Measuring Set AN/PQM-1

FUNCTIONAL DESCRIPTION

The AN/PQM-1 is designed to measure the sound pressure level of underwater noise, and is intended for use in making the measurements called for in noise survey and repair procedures for submarine noise reduction.

No field changes in effect at time of preparation (26 March 1958).

RELATION TO OTHER EQUIPMENT

The AN/PQM-1 is similar to Navy Model OAY Sound Measuring Equipment, differing in that the AN/PQM-1 has an extended frequency range, manual selection of 1 to 3 hydrophones, and multiple band filters.

ELECTRICAL AND MECHANICAL CHARACTERISTICS

SONAR SOUND LEVEL METER DATA

POWER REQUIREMENTS: 110 to 120 v, 50 to 60 cps, single ph, 70 W.

IMPEDANCE
OUTPUT

HEADSETS: 600 ohms to each headset.

MONITOR AMPLIFIER-SPEAKER: 500 ohms.

ANALYZER: 30 ohms.

INPUT

HYDROPHONE: 300 ohms.

OUTPUT POWER: 1 mw continuously.

DISTORTION

	PERCENT	OUTPUT METER READING
TOTAL HARMONIC:	1.5 rms	+10
	0.75 rms	+5
	0.5 rms	0
INTERMODULATION:	0.7	0
	1.5	+5
	4.15	+10

CIRCUIT NOISE (MAX GAIN): Approx 20 db below sound signal level at 40 db meter

April 1958

Test-Field Intensity Measuring

AN/PQM-1

NOISE MEASURING SET

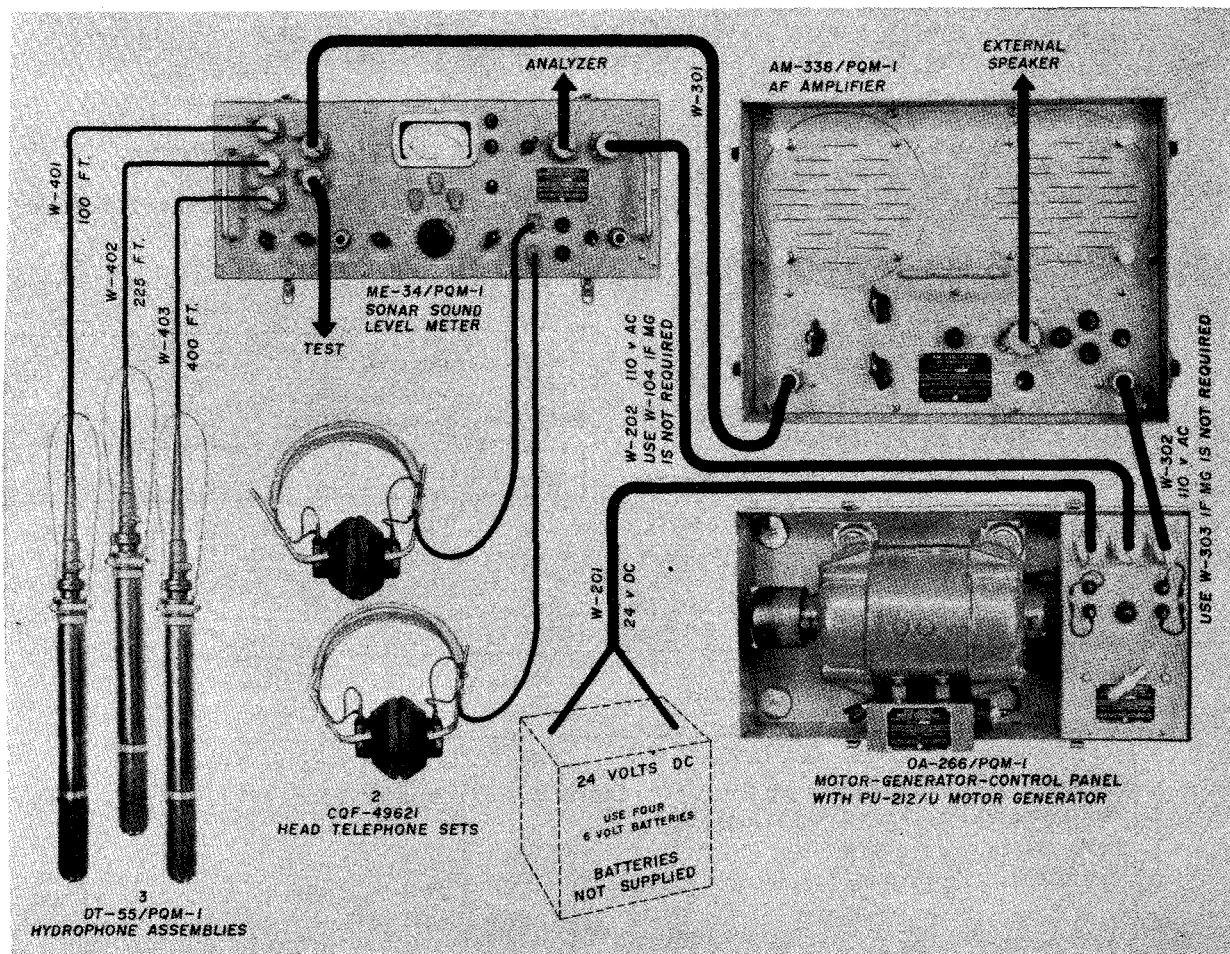

Noise Measuring Set AN/PQM-1

reading.

FREQUENCY RESPONSE

AT METER: -2 db at 20 cps to -0.5 db at 50 cps and 26 kc to -2 db at 32.5 kc.

AT PHONE JACK: -2 db at 30 cps to -0.5 db at 60 cps and 26 kc to -2 db at 32.5 kc.

MOTOR-GENERATOR CONTROL PANEL DATA

OUTPUT: 110 v, 60 cps, single ph, 2.73 amps, 270 W, 90% pf.

INPUT: 24 v DC, 22 amps, 528 W.

SPEED: 3600 rpm.

AMBIENT TEMPERATURE RISE: 40 deg F for continuous operation.

AUDIO FREQUENCY AMPLIFIER DATA

POWER REQUIREMENTS: 115 v, 50 to 60 cps, single ph, 110 va.

POWER OUTPUT: 10 W continuously.

IMPEDANCE

INPUT: 500 ohms.

OUTPUT: 4, 8 and 15 ohms to speaker.
POWER GAIN: Approx 100 db.

DISTORTION: Less than 3% rms at max output.

FREQUENCY RESPONSE: -2 db at 35 cps, -1 db at 40 cps, ± 0.5 db at 8 kc and 10 kc.

SIGNAL-TO-NOISE RATIO: Not less than 62 db at max gain and power output.

VOLUME CONTROL: Min attenuation occurs in full cw position and is approx 50 db with respect to max attenuation position.

TONE CONTROL CHARACTERISTICS

BASE RESPONSE: 0 db to -30 db at 80 cps.

TREBLE RESPONSE: 0 db to -30 db at 10 kc.

HYDROPHONE DATA

OUTPUT IMPEDANCE: 300 ohms.

TYPE: ADP crystal.

UNCLASSIFIED

April 1958

Test-Field Intensity Measuring

NOISE MEASURING SET

AN/PQM-1

OVERLOADING: Signals +145 db above 0.0002 dyne per cm squared can be received without overloading.

TEMPERATURE RANGE: -15 to +150 deg F.

PRESSURE: Capable of withstanding repeated subjections to hydrostatic pressure of 250 lb per sq in.

THERMAL SHOCK: 40 deg F per minute max.

WATER DEPTH: 7 to 500 ft.

(2) 6H6 (1) 6J6 (2) 6L6WGB
 (1) 6SH7 (9) 6SJ7 (1) 6X5GT
 Total Tubes: (20)
 No Crystals used.

REFERENCE DATA AND LITERATURE

NAVSHIPS 91657: Technical Manual for Noise Measuring Set AN/PQM-1.

MANUFACTURER'S OR CONTRACTOR'S DATA

U.S. Navy Underwater Sound Laboratory,
 New London, Conn.
 Project Order 63700/3.

TYPE CLASSIFICATION DESIGN COGNIZANCE BUSHIPS PROCUREMENT COGNIZANCE STOCK NO. R.D.B. IDENT. NO.
--

TUBE AND/OR CRYSTAL COMPLEMENT

(1) OC3W (1) 5U4G (2) 6AU6WA

SHIPPING DATA

NUMBER OF BOXES	CONTENTS AND IDENTIFICATION	VOLUME (Cu.Fr.)	OVERALL DIMENSIONS (inches)	WEIGHT PACKED (lbs.)
1	Sonar Sound Level Meter ME-34/PQM-1	7.4	16 X 24 X 33	150
1	AF Amplifier AM-338/PQM-1	5.6	20 X 20 X 24	95
1	Motor-Generator-Control Panel OA-226/PQM-1	5.4	20 X 20 X 23	145
1	Cable Reel RL-153/PQM-1	7.8	20 X 25 X 27	130
1	Cable Reel Assembly RL-154/PQM-1	9.7	23 X 25 X 29	150
1	Case CY-881/PQM-1 including: Case CY-880/PQM-1	9.4	18 X 20 X 24	140

EQUIPMENT SUPPLIED DATA

QUANTITY PER EQUIPT	NAME AND NOMENCLATURE	OVERALL DIMENSIONS (inches)	WEIGHT (lbs.)
1	Sonar Sound Level Meter ME-34/PQM-1	9-5/8 X 16-1/8 X 24-15/16	85
1	AF Amplifier AM-338/PQM-1	12-1/16 X 12-1/8 X 16-1/4	48
3	Hydrophone Assembly DT-55/PQM-1	3-1/8 X 3-1/8 X 24-11/16	10
1	Motor-Generator-Control Panel OA-226/PQM-1	10-13/16 X 12-1/8 X 23-3/4	78
2	Head Telephone Set NT-49621	3 X 6 X 6	1
1	Cable Reel RL-153/PQM-1	12-1/2 X 17-1/4 X 19	85
1	Cable Reel Assembly RL-154/PQM-1	14-3/4 X 17-1/4 X 21-1/4	90
1	Hydrophone Case CY-881/PQM-1	10-5/8 X 10-7/8 X 36-1/2	85
1	Hydrophone Case CY-880/PQM-1	3-5/8 X 4-13/16 X 27-5/16	22
2	Technical Manual NAVSHIPS 91657	3/8 X 8-1/2 X 11	
1	Noise Survey and Repair Procedures for Submarine Noise Reduction NAVSHIPS 250-371		

UNCLASSIFIED

NOISE MEASURING SET

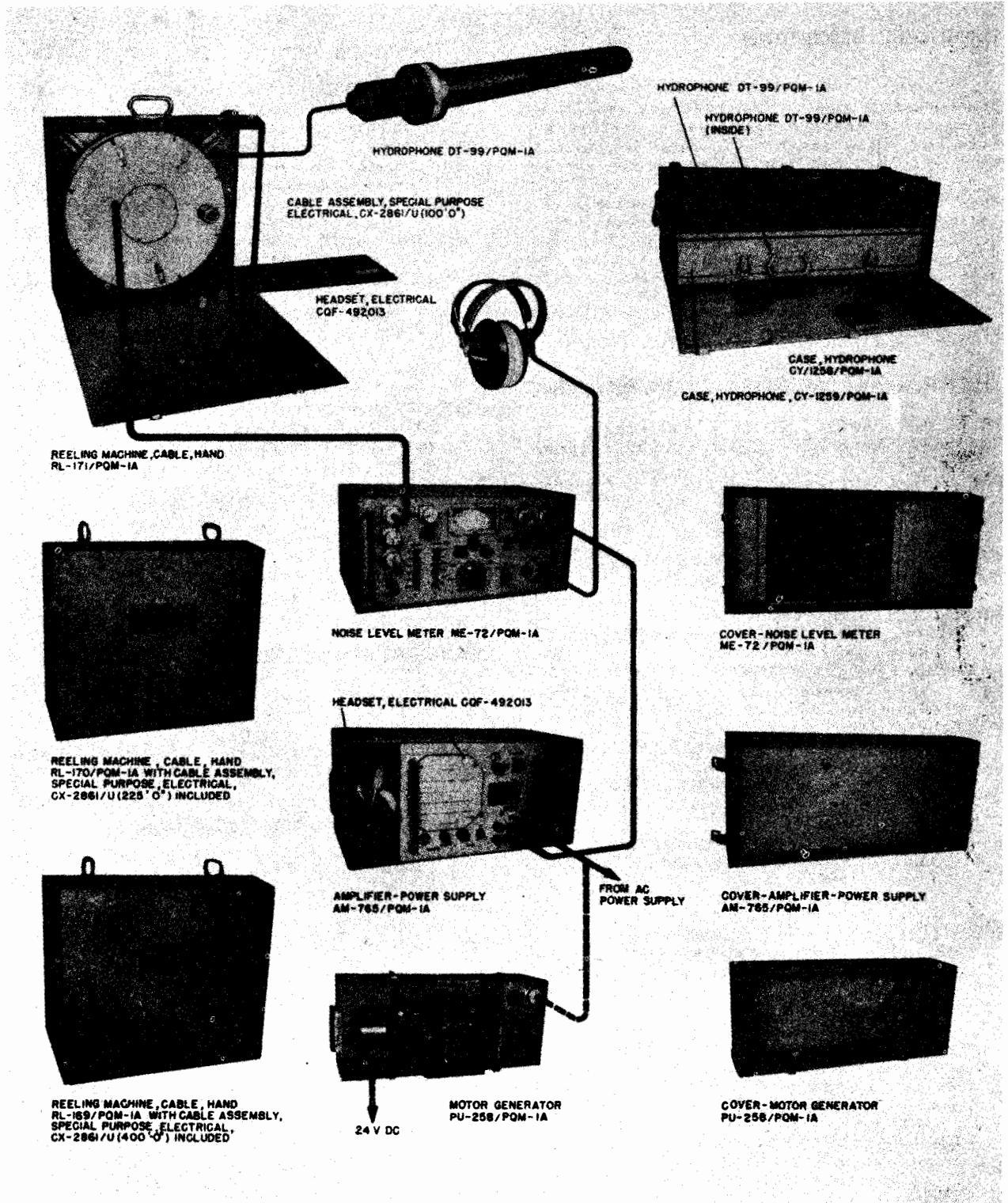

Noise Measuring Set AN/PQM-1A

AN/PQM-1A

NOISE MEASURING SET

December 1956

FUNCTIONAL DESCRIPTION

The AN/PQM-1A is designed to detect the presence and measure the relative amplitude of acoustic energy signals at a particular location. Measurements of acoustic (sound) waves are made in the audio and low super-sonic ranges of frequencies, 20 to 70000 cps. The measured levels are in decibels referred to a standard acoustic pressure level, P.PPPW dynes per square centimeter.

It is intended for use in making the measurements called for in submarine repair procedures towards noise reduction.

No field changes in effect at time of preparation (11 July 1956).

ELECTRICAL AND MECHANICAL CHARACTERISTICS

FREQUENCY RANGE: 20 to 40000 cps.
PRESSURE REFERENCE LEVEL: 0.0002 dynes/cm.

PRESSURE LEVEL RANGE: 30 to 145 db referred to reference level.

PRESENTATIONS

VISUAL: db. meter.

AURAL: Headsets and loudspeaker.

POWER REQUIREMENTS: 105 to 125 v, 50 to 60 cps, single ph, 110 W.

HYDROPHONE DT-99/PQM-1A.

CRYSTAL TYPE: ADP (Ammonium Dehydrogen Phosphate).

CRYSTAL FREQUENCY RESPONSE: 100 to 10000 cps, constant within ± 2 db; 40 to 40000 cps, constant within ± 4 db.

CRYSTAL SENSITIVITY

TERMINATED BY PREAMPLIFIER: ± 65 db vs. 1 v f dyne/cm.

OUTPUT: ± 1 db from 100 to 10000 cps; ± 2 db from 40 to 100 cps and 10 kc to 40 kc.

PREAMPLIFIER: Frequency response flat from 20 cps to 20 kc within ± 0.5 db. Output linear with varying input, response down not more than 1 db at 2.5 v output.

NOISE LEVEL METER ME-72/PQM-1A

FREQUENCY RANGE AND RESPONSE: 50 to 20000 cps, constant within $\pm 1/2$ db; at 20 and ewppp cps no more than 2 db below peak response in range 50 to 20000 cps; Overall (including Hydrophone preamplifier), flat within $\pm 1/2$ db over range 60 to 20,000 cps.

INTENSITY RANGE: Signals 30 to 145 db referred to 0.0002 dynes/cm² within $\pm 1/2$ db.

SIGNAL/NOISE RATION: At max gain, 10 db or better, with signal plus noise input of +30 db.

METER: Calibrated -10 to +10 db, in 1 db steps from -5 to +10 db (no calibration marking between -10 and -5 db).

OSCILLATOR CIRCUIT: 400 cycle sine wave with less than 2% distortion.

OUTPUT CIRCUITS: Provides for simultaneous audio monitoring by two 600 ohm headsets, with good response to 7000 cps; 30 ohm output for audio frequency analyzer; audio output to amplifier and loudspeaker in Amplifier-Power Supply. (Meter reading unaffected by presence of all or part of these loads).

AMPLIFIER-POWER SUPPLY AM-765/PQM-1A

CONTINUOUS SIGNAL POWER OUTPUT: 2 W.

FREQUENCY RESPONSE: 100 to 10000 cps, flat within +3 db including noise level meter output circuit.

DISTORTION: Total less than 5% at max output.

NOISE: More than 60 db below rated output at full gain.

MOTOR-GENERATOR FU-258/PQM-1A

RATED INPUT (FULL LOAD): 24 v DC, 8 amp.

FULL LOAD EFFICIENCY: 51%.

RATED OUTPUT: 110 va, 110 v, 1 amp, single ph, 60 ± 1 cps.

OUTPUT POWER FACTOR: 0.85.

SPEED: 3600 rpm.

TEMPERATURE RISE, CONTINUOUS OPERATION: 40°C.

FILTERS: Radio interference type, at input and output.

MANUFACTURER'S OR CONTRACTOR'S DATA

Lanagan and Hoke, Inc., Warrington, Pa.
Contract Nobsr 52258, dated 12 February 1951.

Approximate Cost: \$3640.00 with equipment spares.

TUBE AND/OR CRYSTAL COMPLEMENT

(1) 6AG7 (8) 6SJ7 (2) 6X5
(3) 12AT7 (2) OD3

Total Tubes: (16)

(2) 1N35

Total Crystals: (2)

REFERENCE DATA AND LITERATURE

NAVSHIPS 92277: Manuscript of Technical for Noise Measuring Set AN/PQM-1A.

TYPE CLASSIFICATION	BUSHIPS
DESIGN COGNIZANCE	MIL-N-15576 (SHIPS)
PROCUREMENT COGNIZANCE	
STOCK NO.	
R.D.B. IDENT. NO.	

NOISE MEASURING SET

AN/PQM-1A

SHIPPING DATA

NUMBER OF BOXES	CONTENTS AND IDENTIFICATION	VOLUME (Cu.Ft.)	OVERALL DIMENSIONS (inches)	WEIGHT PACKED (lbs.)
1	Noise Lever Meter ME-72/PQM-1A Amplifier Power Supply AM-765/PQM-1A (1) Headset, Electrical NT-492013	6.39	16-9/10 X 24-9/10 X 25-1/5	110
1	Motor-Generator PU-258/PQM-1A	1.7	10-3/5 X 12-3/5 X 22	56
1	Case, Hydrophone CY-1258/PQM-1A Case, Hydrophone CY-1259/PQM-1A 3 Hydrophones DT-99/PQM-1A	2.41	11-1/2 X 12-9/10 X 28-1/10	62
1	Reeling Machine, Cable, Hand RL-169/PQM-1A Cable Assembly, Special Purpose, Electrical CX-2861/U	3.9	15 X 20-1/2 X 22 400 ft	96
1	Reeling Machine, Cable, Hand, RL-170/PQM-1A Cable Assembly, Special Purpose, Electrical CX-2861/U	3.15	12-1/5 X 30-2/5 X 21-9/10 225 ft	
1	Reeling Machine, Cable Hand RL-171/PQM-1A Cable Assembly, Special Purpose, Electrical CX-2861/U	2.42	9-1/2 X 20-1/10 X 21-9/10 100 ft	49
11	Equipment Spares	1.1	8-1/2 X 11-4/5 X 19	32

EQUIPMENT SUPPLIED DATA

QUANTITY PER EQUIP	NAME AND NOMENCLATURE	OVERALL DIMENSIONS (inches)	WEIGHT (lbs.)
1	Noise Level Meter ME-72/PQM-1A	10-3/10 X 13-1/2 X 21-9/10	40
3	Hydrophones DT-99/PQM-1A	22 X 3-1/4 X dia.	10
1	Amplifier-Power Supply AM-765/PQM-1A	10-1/10 X 13-2/5 X 21-9/10	45
1	Motor-Generator PU-258/PQM-1A	9-1/10 X 10-1/10 X 19-1/2	55
1	Reeling Machine, Cable, Hand RL-169/PQM-1A	12-1/5 X 17-4/5 X 19-1/10	87
1	Cable Assembly, Special Purpose, Electrical CX-2861/U	400 ft	
1	Reeling Machine, Cable, Hand RL-170/PQM-1A	9-2/5 X 17-4/5 X 19-1/10	65
1	Cable Assembly, Special Purpose, Electrical CX-2861/U	225 ft	
1	Reeling Machine, Cable, Hand RL-171/PQM-1A	7 X 17-4/5 X 19-1/10	43
1	Cable Assembly, Special Purpose, Electrical CX-2861/U	100 ft	
1	Case, Hydrophone CY-1258/PQM-1A	9-2/5 X 10-1/2 X 25-1/2	20
1	Case, Hydrophone CY-1259/PQM-1A	3-9/10 X 4-3/5 X 23-2/5	15
2	Sets of Headsets, Electrical NT-492013	3 X 6 X 6	1

December 1956

RADIO TEST SET

AN/PRM-1,1A,1B

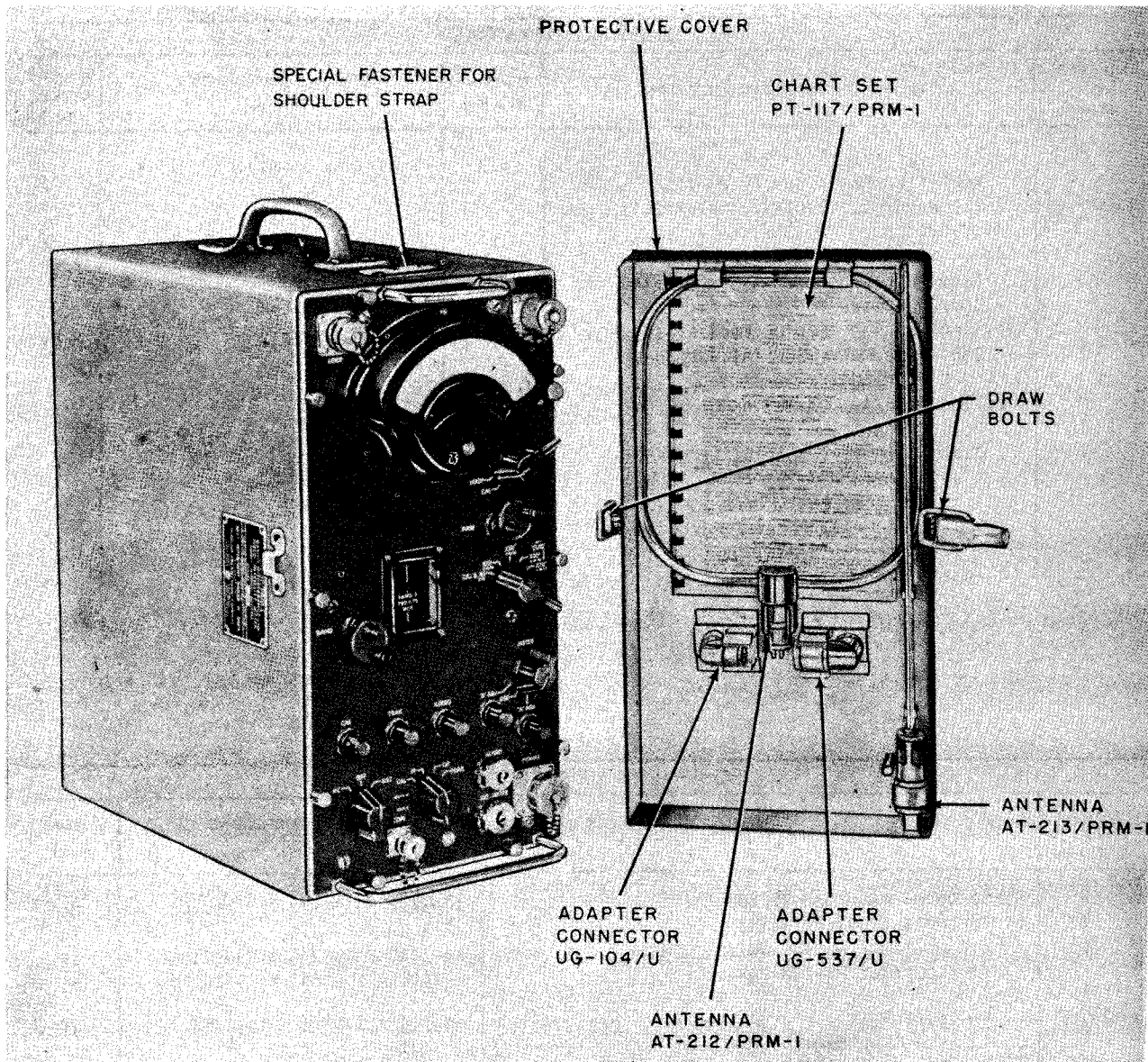

Radio Test Set AN/PRM-1, 1A, 1B

FUNCTIONAL DESCRIPTION

The AN/PRM-1, AN/PRM-1A, and AN/PRM-1B are portable test instruments which are designed for making radio interference surveys to determine the source of radiated or conducted interference from any source within their frequency range.

They may also be used for making field intensity measurement surveys for adjusting directive antennas or for exploring radiation patterns, where field intensity may vary over a wide range of values.

The instruments may also be used as sensitive radio frequency microvolt meters.

Data on this sheet reflects the following field changes, FC NO. 1 for the AN/PRM-1, (17 July 1956).

RELATION TO OTHER EQUIPMENT

The AN/PRM-1, AN-PRM-1A and AN/PRM-1B are similar instruments except for power supply modifications.

The AN/PRM-1B does not include a beat

UNCLASSIFIED

4.5 AN/PRM-1: 1

AN/PRM-1,1A,1B

RADIO TEST SET

December 1956

frequency oscillator.

Equipment Required but not Supplied: (2) 1.5 volt, batteries, BA-35, (2) 45 volt batteries, BA-36, (2) 4.5 volt batteries, BA-31, (2) 1.5 volt batteries, BA-58 (BA-30 for AN/PRM-1A.

ELECTRICAL AND MECHANICAL CHARACTERISTICS

FREQUENCY RANGE: 150 kc to 25 mc.
 BAND AND INTERMEDIATE FREQUENCY DATA
 BAND 1: 150 to 320 kc with 455 kc IF.
 BAND 2: 320 to 750 kc with 1600 kc IF.
 BAND 3: 750 kc to 1.75 mc with 455 kc IF.
 BAND 4: 1.75 to 3.8 mc with 455 kc IF.
 BAND 5: 3.8 to 8 mc with 1600 kc IF.
 BAND 6: 8 to 15 mc with 1600 kc IF.
 BAND 7: 15 to 25 mc with 1600 kc IF.

SELECTIVITY

BANDWIDTH: 3 to 5 kc at 6 db down and 20 to 30 kc at 60 db down.

IMAGE AND INTERMEDIATE FREQUENCY REJECTION: 50 db or better.

SENSITIVITY

AS RF BOLT METER: 1 uv per meter.
 AS FIELD INTENSITY METER: 2 uv per meter, with antenna AT-213/PRM-1.

AUDIO OUTPUT: 100 mw at 600 ohm impedance load based on 10 uv RF input, modulated 30% at 1000 cycles.

DYNAMIC RANGE: 16 db.

AC POWER SOURCE REQUIRED

PP-472/PRM-1: 105 to 125 v, 50 to 1600 cps, single ph, 25 W, 87% pf.

PP-472A/PRM-1 and PP-472B/PRM-1: 105 to 125 v or 210 to 250 v, 50 to 1600 cps, single ph, 25 W, 87% pf.

PP-472C/PRM-1: 105 to 125 v or 210 to 250 v, 50 to 1000 cps, single ph, 30 W at 115 v, 60 cps, 87% pf.

BATTERIES REQUIRED WHEN AC IS NOT AVAILABLE: 2 type BA-35, and 2 type BA-36 batteries.

BATTERIES USED AT ALL TIMES: 2 type BA-31, and 2 type BA-58 batteries. (2 type BA-30 for AN/PRM-1A.

MANUFACTURER'S OR CONTRACTOR'S DATA

AN/PRM-1

Stoddard Aircraft Radio Co., Hollywood, California.
 Contract NObsr 39262, dated 27 June

4.5 AN/PRM-1: 2

1947.

Contract NObsr 43370, dated 9 June 1949.

AN/PRM-1A

Stoddard Aircraft Radio Co., Hollywood, California.

Contract NObsr 52629, dated 23 June 1951

Contract NObsr 57211, dated 8 February 1952.

AN/PRM-1B

Espey Manufacturing Co. Inc., New York, N. Y.

Contract NObsr 49217, dated 19 June 1950.

Approximate Cost: \$2750.00 with equipment spares.

TUBE AND/OR CRYSTAL COMPLEMENT

AN/PRM-1

(1) 1R5 (3) 3A5 (1) 1U5 (1) OA3/VR75
 (4) 1T4 (4) 3V4 (1) 2A20

Total Tubes: (15)

AN/PRM-1A

(1) 1R5 (1) 1U5 (4) 3A5 (1) OA3/VR75
 (4) 1T4 (1) 2A20 (4) 3V4 (1) OA3/VR75

Total Tubes: (16)

AN/PRM-1B

(1) 1R5 (4) 1T4 (1) 1U5
 (2) 3A5 (4) 3V4 (1) OA3/VR75

Total Tubes: (13)

AN/PRM-1B

(1) 1N69

Total Crystals: (1)

REFERENCE DATA AND LITERATURE

NAVSHIPS 91255: Manuscript of Technical Manual for Radio Test Set AN/PRM-1.

NAVSHIPS 91806: Manuscript of Technical Manual for Radio Test Set AN/PRM-1A.

NAVSHIPS 92263: Manuscript of Technical Manual for Radio Test Set AN/PRM-1B.

TYPE CLASSIFICATION
DESIGN COGNIZANCE BUSHIPS
PROCUREMENT COGNIZANCE
STOCK NO.
R.D.B. IDENT. NO.

UNCLASSIFIED

UNCLASSIFIED

Radio Test Set

December 1956

RADIO TEST SET

AN/PRM-1,1A,1B

SHIPPING DATA

NUMBER OF BOXES	CONTENTS AND IDENTIFICATION	VOLUME (Cu.Ft.)	OVERALL DIMENSIONS (inches)	WEIGHT PACKED (lbs.)
AN/PRM-				
1	1A			
1	1B			
1	Radio Test Set AN/PRM-1	8	21-1/2 X 23 X 28	141
1	Radio Test Set AN/PRM-1A	8	21-1/2 X 23 X 28	141
1	Radio Test Set AN/PRM-1B	8	21-1/2 X 23 X 28	141

EQUIPMENT SUPPLIED DATA

QUANTITY PER EQUIPT	NAME AND NOMENCLATURE	OVERALL DIMENSIONS (inches)	WEIGHT (lbs.)
AN/PRM-			
1	1A		
1	1B		
1	Case (transit) CY-749/PRM-1 containing: Radio Interference-Field Intensity Meter IM-37/PRM-1	11-3/4 X 18-3/4 X 19-1/4	17
1	Radio Interference-Field Intensity Meter IM-37A/PRM-1	7-9/16 X 14 X 16-7/16	37
1	Radio Interference-Field Intensity Meter IM-37B/PRM-1	7-9/16 X 14 X 16-7/16	36.25
1	Radio Interference-Field Intensity Meter IM-378/PRM-1	7-9/16 X 14 X 16-7/16	37
1	Antenna AT-211/PRM-1		
1	Antenna AT-212/PRM-1	8-1/4 dia	
1	Antenna AT-213/PRM-1	41 lg	
1	RF Probe MX-980/PRM-1		
1	Impedance Matching Network CU-195/PRM-1		
1	Impedance Matching Network CU-196/PRM-1		
1	Impedance Matching Network CU-197/PRM-1		
1	Adapter UG-104/U		
1	Adapter UG-105/U		
1	Adapter UG-537/U		
1	Special Purpose Cable Assembly CG-572/U	240 lg	
1	Chart Set PT-117/PRM-1		
1	Set of Headphones NT-49509		
1	Set of Headphones NT-49507A		
1	Set of Headphones NT-49505		
2	Technical Manuals NAVSHIPS 91255		
2	Technical Manuals NAVSHIPS 91806		
2	Technical Manuals NAVSHIPS 92263		
1	Shoulder Strap		
1	Case CY-750/PRM-1 containing: Power Supply PP-472/PRM-1	10-3/4 X 15-5/8 X 18-3/8 7-17/32 X 8-3/8 X 10-1/2	16 16.50

UNCLASSIFIED

4.5 AN/PRM-1: 3

AN/PRM-1,1A,1B

RADIO TEST SET

December 1956

EQUIPMENT SUPPLIED DATA

QUANTITY PER EQUIPT			NAME AND NOMENCLATURE	OVERALL DIMENSIONS (inches)	WEIGHT (lbs.)
1	1A	1B			
1*			Power Supply PP-472A/PRM-1	7-17/32 X 8-3/8 X 10-1/2	18
	1		Power Supply PP-472B/PRM-1	7-17/32 X 8-3/8 X 10-1/2	14.50
		1	Power Supply PP-472C/PRM-1	7-17/32 X 8-3/8 X 10-1/2	16.50
1	1	1	Ammeter ME-33/U		
1	1	1	Power Cable Assembly NT-62480	76 1g	
1	1	1	Special Purpose Cable Assembly NT-62481	120 1g	
1	1	1	Special Purpose Cable Assembly CG-571/U	240 1g	
1	1	1	Cord CG-444/U	240 1g	
1	1	1	Special Purpose Cable Assembly CG-573/U	36 1g	

* Power supply PP-472A/PRM is supplied on contract N0bsr-43370 only.

UNCLASSIFIED

February 1960

Test-Field Intensity Measuring

FIELD STRENGTH MEASURING SET

AN/PRM-2

FUNCTIONAL DESCRIPTION

Field Strength Measuring Set AN/PRM-2 is designed to determine the field strength of low frequency Loran signals.

No field changes in effect at time of preparation (21 October 1959).

TUBE AND/OR CRYSTAL COMPLEMENT

No Electron Tube or Crystal Data Available.

REFERENCE DATA AND LITERATURE

Nomenclature Card for Field Strength Measuring Set AN/PRM-2.

ELECTRICAL AND MECHANICAL CHARACTERISTICS

FREQUENCY RANGE: 130 to 230 kc.

MANUFACTURER'S OR CONTRACTOR'S DATA

Harvey Radio Laboratories Inc, Cambridge, Mass.

TYPE CLASSIFICATION (NAVY)

DESIGN COGNIZANCE USAF

PROCUREMENT COGNIZANCE

STOCK NO.

R.D.B. IDENT. NO.

EQUIPMENT SUPPLIED DATA

QUANTITY PER EQUIPT	NAME AND NOMENCLATURE	OVERALL DIMENSIONS (inches)	WEIGHT (lbs.)
1	Field Strength Measuring Set AN/PRM-2 including:		
1	Field Strength Meter IM-35/PRM-2		
1	Power Supply PP-497/PRM-2		
1	Antenna AT-226/PRM-2		
1	Antenna AT-227/PRM-2		
1	Antenna Coupler CU-218/PRM-2		
1	Antenna Support AB-173/PRM-2		
1	Tripod MT-712/PRM-2		
1	Bag CU-193/PRM-2		
1	Set of Cables		

UNCLASSIFIED

4.5 AN/PRM-2: 1

SOUND MEASURING SET

AN/SQM-1

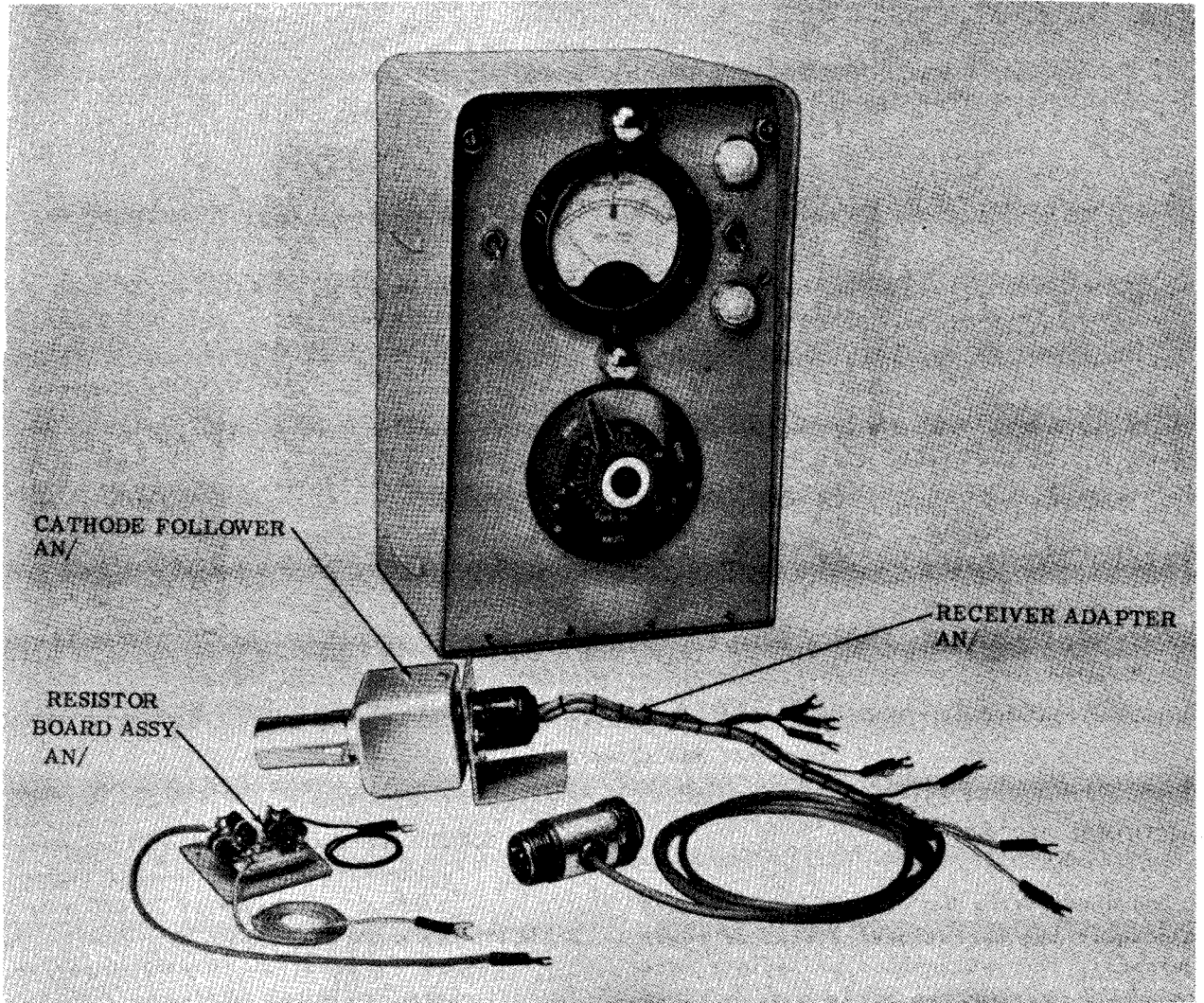

Sound Measuring Set AN/SQM-1

AN/SQM-1

SOUND MEASURING SET

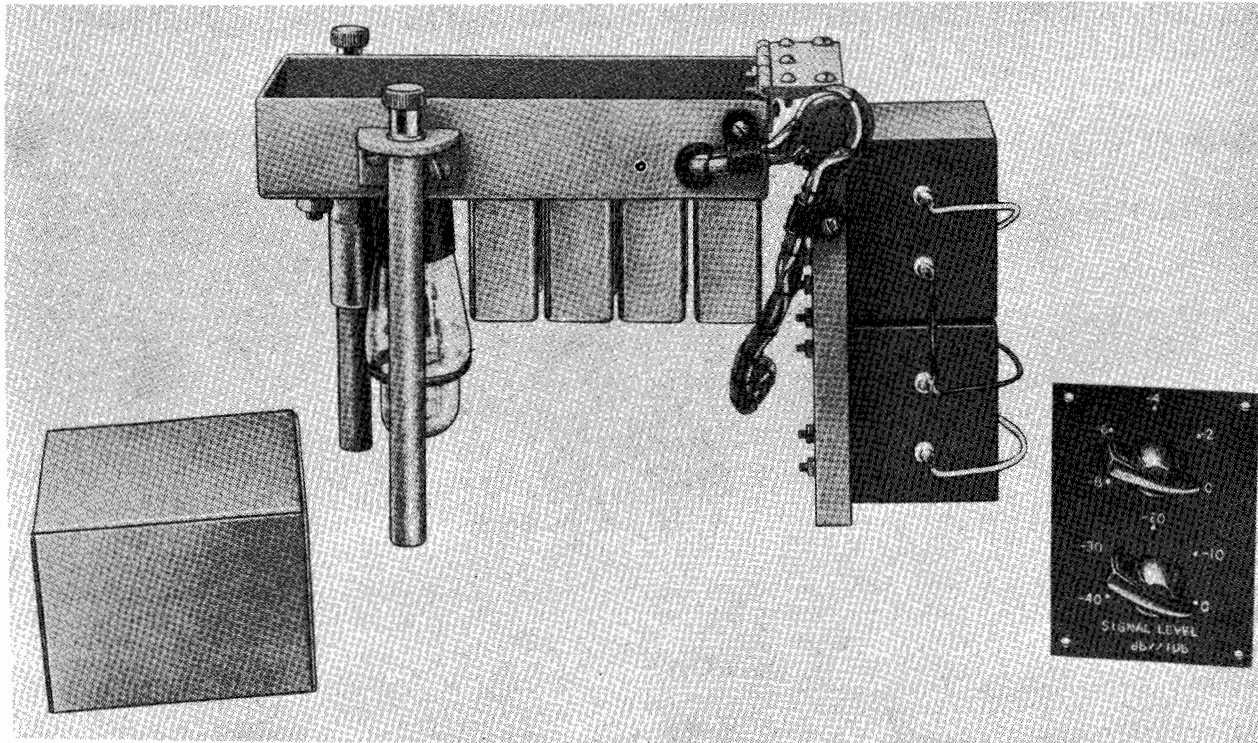

Sound Measuring Set AN/SQM-1

FUNCTIONAL DESCRIPTION

Sound Measuring Set AN/SQM-1 is designed to measure the operational status of sonar equipment. It also enables the ship's personnel to measure the minimum detectable signal level either for use in obtaining figures-of-merit or as an aid to determining the need for corrective maintenance, and it provides an accurate method of injecting target echoes for operator training purposes.

No field changes in effect at time of preparation (8 October 1959).

ELECTRICAL AND MECHANICAL CHARACTERISTICS

SOUND MEASURING METER (ME-173/SQM-1).

SOURCE LEVEL MEASUREMENTS

RANGE: 105 to 125 db (0 db = 1 microbar).

SONAR: Transmitting 30 milliseconds pulse with a ping internal corresponding to a range of 10,000 yds.

NOISE LEVEL MEASUREMENTS

RANGE: 0 to 58 db (0 db = 1 microbar).

QUICK REFERENCE: Color ring scale.

OPERATING POWER: 115 v $\pm 10\%$, 60 cps $\pm 5\%$, 1 ph, 30 W.

RELAY SUB-CHASSIS (A500)

OPERATING POWER: ± 280 v DC $\pm 10\%$.

INPUT IMPEDANCE: 500 ohms.

OUTPUT IMPEDANCE: 500 ohms.

RANGE: 0 to 48 db.

CATHODE FOLLOWER (A200)

OPERATING POWER: +250 v DC, 6.4 ma $\pm 10\%$.

6.3 v AC, 0.3 ma $\pm 10\%$.

MANUFACTURER'S OR CONTRACTOR'S DATA

Hickok Electrical Instrument Co., Cleve-

UNCLASSIFIED

February 1960

Test-Field Intensity Measuring

SOUND MEASURING SET

AN/SQM-1

land, Ohio.

Contract NObsr-75394, dated 27 June 1958.

REFERENCE DATA AND LITERATURE

NAVSHIPS 93417: Technical Manual for SOUND MEASURING SET AN/SQM-1.

TUBE AND/OR CRYSTAL COMPLEMENT

(1) OD3	(1) OA2	(1) 6AT6
(1) 6AU6	(1) 6X4	(1) 5751
(4) 5814	(1) 12AT7	

Total Tubes: (11)

No Crystals used.

TYPE CLASSIFICATION (NAVY)
DESIGN COGNIZANCE USN, BUSHIPS
PROCUREMENT COGNIZANCE SPEC: MIL-S-19885A
STOCK NO. (SHIPS)
R.D.B. IDENT. NO.

SHIPPING DATA

NUMBER OF BOXES	CONTENTS AND IDENTIFICATION	VOLUME (Cu.Ft.)	OVERALL DIMENSIONS (inches)	WEIGHT PACKED (lbs.)
1	Sound Measuring Set AN/SQM-1			

EQUIPMENT SUPPLIED DATA

QUANTITY PER EQUIPT	NAME AND NOMENCLATURE	OVERALL DIMENSIONS (inches)	WEIGHT (lbs.)
1	Sound Measuring Set AN/SQM-1 includes:		
1	Sound Measuring Meter ME-173/SQM-1		
1	Cathode Follower A200		
1	Resistor Board Assy A300		
1	Receiver Adaptor Assy A400		
1	Relay Sub-Chassis A500		
1	Signal Level Switch Assy A600		
1	Box of Parts A700		
1	Technical Manual		

UNCLASSIFIED

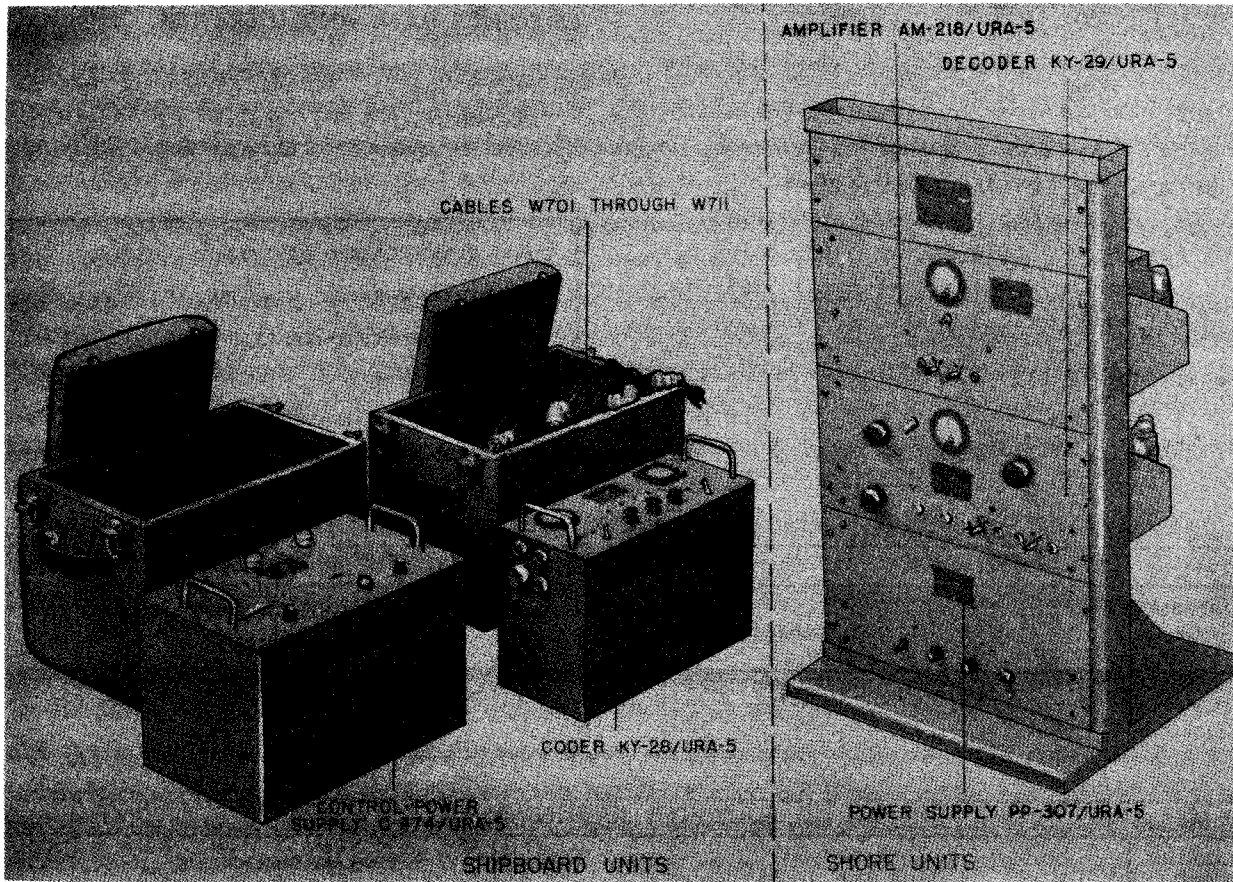

Coder-Decoder Group AN/URA-5

FUNCTIONAL DESCRIPTION

The AN/URA-5 is intended for use with the Radiation Pattern Recorder Set AN/URH-1 to enable shore station recording of shipboard antenna radiation patterns.

In operation a signal of known characteristic is transmitted from a transmitter at a fixed, shore location. A receiver is connected to the shipboard antenna under test and tuned to the signal. As the ship is rotated through a 360 deg turn, the variations in signal as received by the antenna under test and the information received from the ships gyro system are coded into three audio tones and transmitted via a radio link to shore. On shore the information is decoded and supplied to the Radiation Pattern Recorder RD-43/URH-1 and its associated amplifiers for recording on a polar graph. Two plotting methods are available. Logarithmic and Linear.

No field changes in effect at time of preparation (29 June 1956).

RELATION TO OTHER EQUIPMENT

Equipment Required but not Supplied: (1) Radiation Pattern Recorder AN/URH-1, (1) Technical Manual NAVSHIPS 91132(A), (1) Antenna, (1) Radio Receiver, (1) Ship to Shore Radio Link, transmitter and receiver, (1) Intercommunication system, between ship and shore

ELECTRICAL AND MECHANICAL CHARACTERISTICS

FREQUENCIES OF CODED CARRIER TONES

PEN CHANNEL: 200 to 400 cps.
A CHANNEL: 600 to 1200 cps.
B CHANNEL: 1475 to 2950 cps.

AN/URA-5

CODER-DECODER GROUP

December 1956

POWER INPUT

SHORE: 115 v, 60 cps, single ph, 200 W.
 SHIP: 115 v, 60 cps, single ph, 162 W.
 POWER FACTOR: 90%.

REFERENCE DATA AND LITERATURE

NAVSHIPS 91225: Technical Manual for Coder-Decoder Group AN/URA-5.

MANUFACTURER'S OR CONTRACTOR'S DATA

Hoffman Radio Corp., Los Angeles, Calif.
 Contract NObsr-39426, dated 30 June 1947.

Approximate Cost: \$4920.00 with equipment spares.

TUBE AND/OR CRYSTAL COMPLEMENT

(10) 6SL7GT	(2) 6AS7G	(1) OB2
(5) 6V6GT/G	(8) 6SN7GT	(1) 902-A
(2) 5R4GY	(1) 65J7	(3) 884
(2) 6SH7	(1) 6H6	(1) 6X5GT
(2) OD3/VR150	(2) 6AC7	(2) OA3/VR75

Total Tubes: (43)

TYPE CLASSIFICATION
DESIGN COGNIZANCE BUSHIPS
PROCUREMENT COGNIZANCE
STOCK NO.
R.D.B. IDENT. NO.

SHIPPING DATA

NUMBER OF BOXES	CONTENTS AND IDENTIFICATION	VOLUME (Cu.Ft.)	OVERALL DIMENSIONS (inches)	WEIGHT PACKED (lbs.)
1	Standard 19" Relay Rack	12.5	22-1/5 X 24 X 40	112
1	Control-Power Supply C-474/URA-5	5.6	16-3/4 X 20-1/4 X 28-1/4	141
1	Coder KY-28/URA-5	5.6	16-3/4 X 20-1/4 X 28-1/4	122
1	Amplifier AN-218/URA-5	5.6	16-3/4 X 20-1/4 X 28-1/4	113
1	Decoder KY-29/URA-5	5.6	16-3/4 X 20-1/4 X 28-1/4	99
1	Power Supply PP-307/URA-5	5.6	16-3/4 X 20-1/4 X 28-1/4	115
1	Equipment Spare Parts	4.5	14-1/2 X 18-1/2 X 28-3/4	207

EQUIPMENT SUPPLIED DATA

QUANTITY PER EQUIPT	NAME AND NOMENCLATURE	OVERALL DIMENSIONS (inches)	WEIGHT (lbs.)
1	Control-Power Supply C-474/URA-5	11-3/4 X 14-1/4 X 19-3/4	83
1	Coder KY-28/URA-5	11-3/4 X 14-1/4 X 19-3/4	57.5
1	Amplifier AM-218/URA-5	8-3/4 X 13-3/4 X 19	38
1	Decoder KY-29/URA-5	8-3/4 X 11-7/8 X 19	24.5
1	Power Supply PP-307/URA-5	8-3/4 X 9-3/4 X 19	40.25
1	Standard 19" Relay Rack	19 X 20-1/2 X 35-1/4	30.25
1	Set of Equipment Spare Parts	12-1/4 X 16 X 25-1/2	175
2	Technical Manuals NAVSHIPS 91225		

December 1956

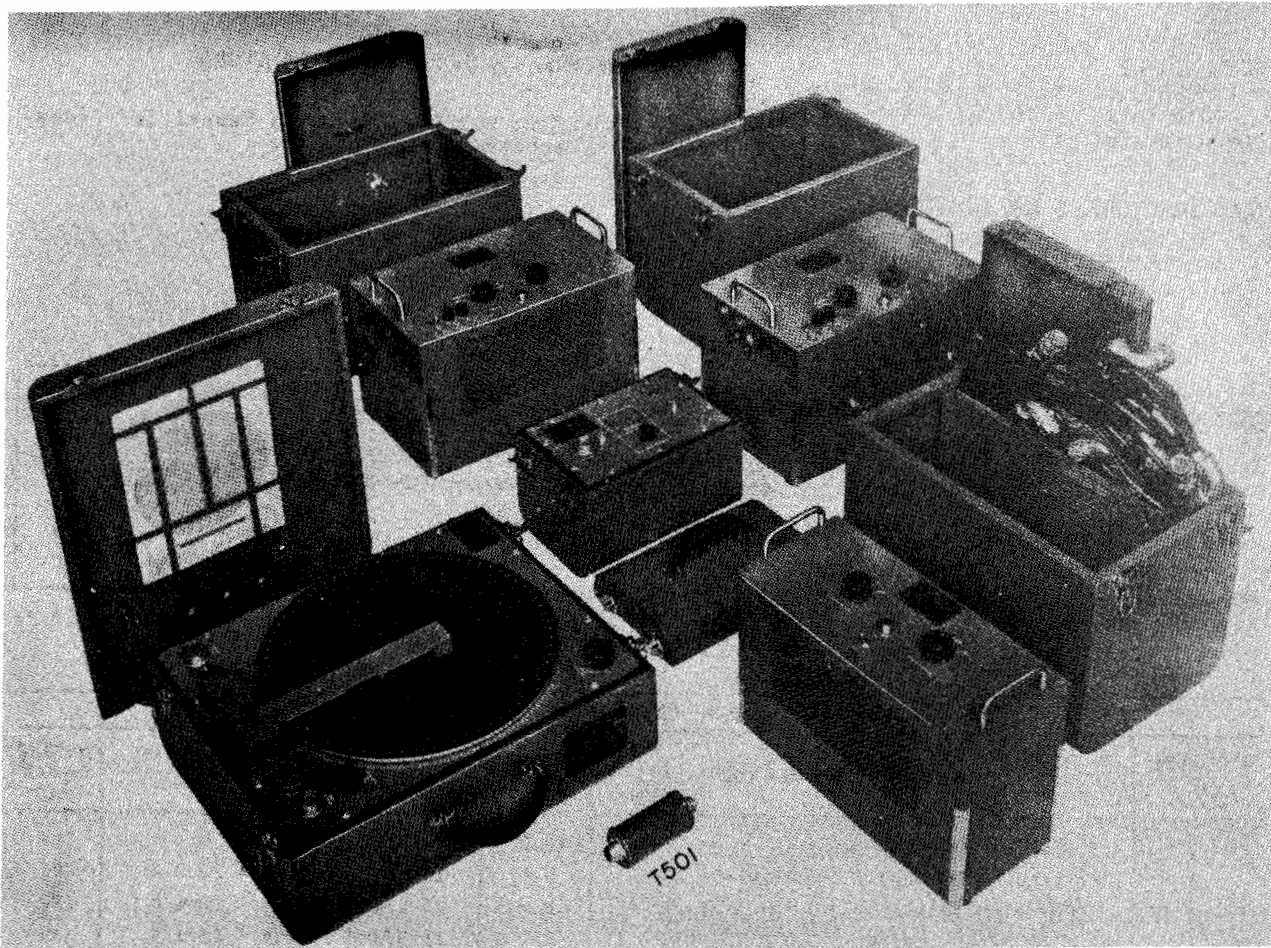
RADIATION PATTERN RECORDER SET**AN/URH-1**

Radiation Pattern Recorder Set AN/URH-1

FUNCTIONAL DESCRIPTION

The AN/URH-1 is a group of apparatus that automatically records polar plots of shipboard antenna horizontal directivity patterns on polar charts.

In operation, a signal of known polarization is transmitted from a remote point, and a receiver is connected to the shipboard antenna under test. The strength of the received signal controls the radial travel of a pen on a suitable polar chart, while the ship's heading controls the angular chart position by means of information received from the ship's gyro system. There are three alternative plotting methods available; linear, semi-logarithmic and logarithmic.

No field changes in effect at time of preparation (7 July 1956).

RELATION TO OTHER EQUIPMENT

Equipment Required but not Supplied: (1) Source of Rotational Control Voltages from ships Gyro, (1) Navy Radio Receiver, (1) Antenna, Transmitting and Receiving radiation pattern, (1) ink.

ELECTRICAL AND MECHANICAL CHARACTERISTICS

FREQUENCY RANGE: 1.5 to 18 mc.
 POWER FACTOR: 90%.
 POWER SOURCE REQUIRED: 115 v, 60 cps, single ph, 500 W.

AN/URH-1

RADIATION PATTERN RECORDER SET

December 1956

MANUFACTURER'S OR CONTRACTOR'S DATA

Hoffman Radio Corp., Los Angeles 7, Calif.
Contract NObsr-39426, dated 30 June 1947.

Approximate Cost: \$4920.00 with equipment spares.

REFERENCE DATA AND LITERATURE

NAVSHIPS 91132(A): Technical Manual for Radiation Pattern Recorder Set AN/URH-1.

TUBE AND/OR CRYSTAL COMPLEMENT

(4) OA2	(3) 5R4GY	(2) 6AC7
(1) 6J6	(4) 6L6G	(4) 6SJ7
(10) 6SL7GT	(2) 6SN7GT	(2) 6V6GT/G
(2) 6X5GT	(2) 6Y6G	
Total Tubes: (36)		

TYPE CLASSIFICATION
DESIGN COGNIZANCE BUSHIPS
PROCUREMENT COGNIZANCE
STOCK NO.
R.D.B. IDENT. NO.

SHIPPING DATA

NUMBER OF BOXES	CONTENTS AND IDENTIFICATION	VOLUME (Cu.Ft.)	OVERALL DIMENSIONS (inches)	WEIGHT PACKED (lbs.)
1	Radiation Pattern	5.2	13-1/2 X 24 X 27-1/2	97
1	Electronic Control Amplifier AM-216/URH-1	4.9	16 X 21 X 25	110
1	Electronic Control Amplifier AM-217/URH-1	4.9	16 X 21 X 25	106
1	Electronic Control Amplifier AM-217/URH-1	4.9	16 X 21 X 25	106
1	Attenuator CN-78/URH-1	2.1	12-1/2 X 16 X 18-1/2	37-1/2
1	Equipment Spare Parts, Box 1	5.4	14-1/4 X 18-1/2 X 35	250

EQUIPMENT SUPPLIED DATA

QUANTITY PER EQUIPT	NAME AND NOMENCLATURE	OVERALL DIMENSIONS (inches)	WEIGHT (lbs.)
1	Radiation Pattern Recorder RD-43/URH-1	8-5/8 X 20 X 20-1/2	49
1	Electronic Control Amplifier AM-216/URH-1	11-3/4 X 17 X 17-3/4	66-1/4
2	Electronic Control Amplifier AM-217/URH-1	11-3/4 X 17 X 17-3/4	64-1/4
1	Attenuator CN-78/URH-1	7-7/8 X 11-5/8 X 12	13-1/2
1	Set of Equipment Spare Parts	12-5/16 X 16-9/16 X 31-1/8	199
24	Sheets of Polar Graph Paper	8-1/2 X 11	
2	Technical Manuals NAVSHIPS 91132(A)	8-1/2 X 11	

FIELD STRENGTH METER

AN/URM-102(XN-1)

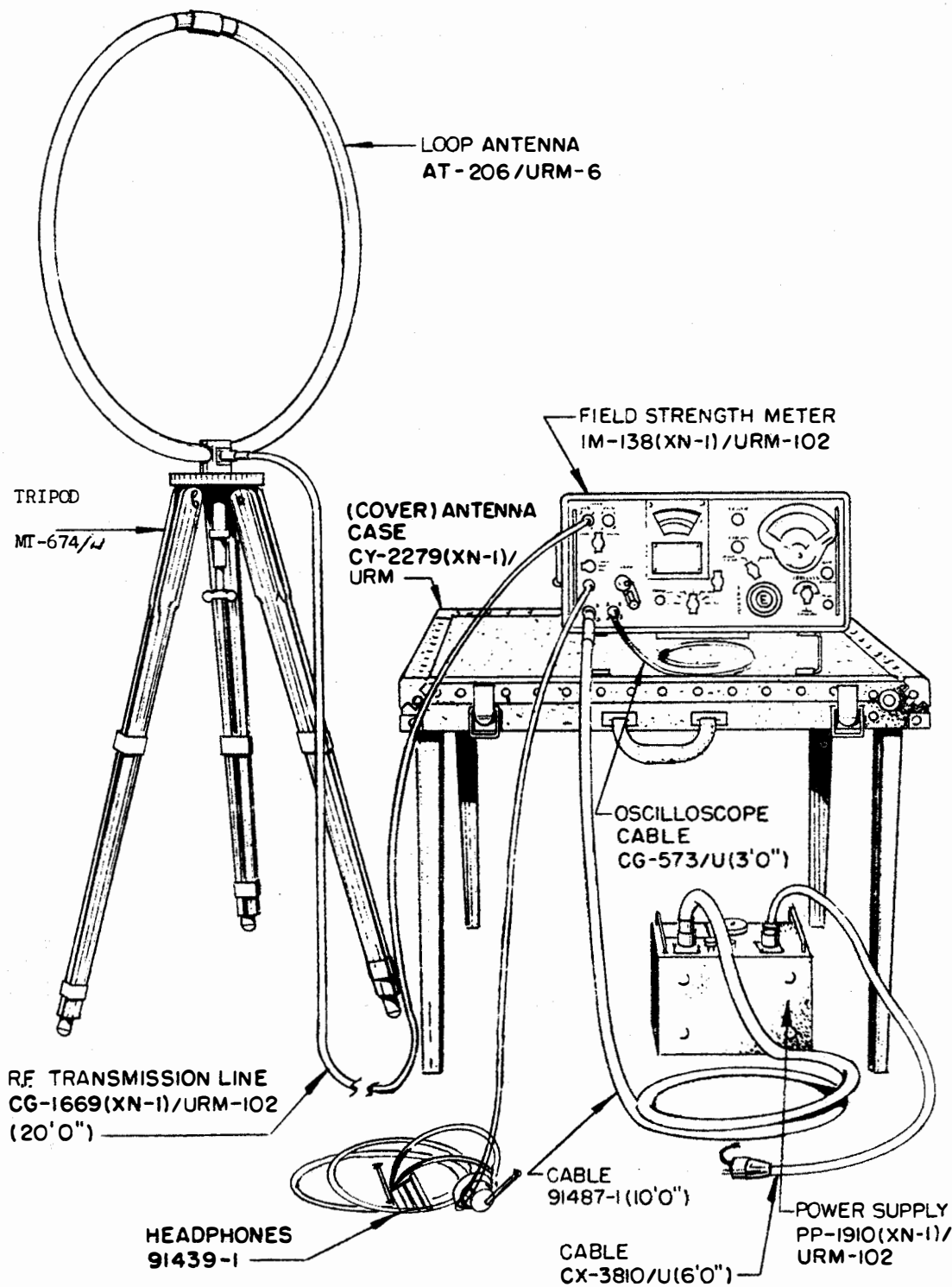

Field Strength Meter AN/URM-102(XN-1)

Test-Field Intensity Measuring
AN/URM-102(XN-1) FIELD STRENGTH METER

FUNCTIONAL DESCRIPTION

Field Strength Meter AN/URM-102(XN-1) is designed for measurement, in microvolts-per-meter, of the field strength of the radiated signals within the frequency range of the equipment -3 to 30 kc.

No field changes in effect at time of preparation (19 February 1960).

FREQUENCY: 50 to 60 cy.
POWER REQUIREMENTS: Approx 125 W.

MANUFACTURER'S OR CONTRACTOR'S DATA

Stoddart Aircraft Radio Co., Inc., Los Angeles, California.
Contract NObsr-72631.

ELECTRICAL AND MECHANICAL CHARACTERISTICS

TYPE OF RECEIVER: Superheterodyne.
FREQUENCY RANGE: 3 to 30 kc.
INTERMEDIATE FREQUENCY: 41 kc.
CALIBRATION INPUT IMPEDANCE: 50 ohms.
SELECTIVITY (CONTINUOUSLY VARIABLE): 6 db attenuation bandwidth variable between 20 cps and 200 cps.
UNDESIRABLE RESPONSE, INCLUDING IF AND IMAGE: Better than 60 db down.
DETECTOR FUNCTION: Field strength and peak functions provided.
ATTENUATION: Six increments, 0 to 120 db.
METER INDICATION: Single linear scale reading from 1 to 11.
AUDIO OUTPUT: Audio power is at least 100 mw across 600 ohm noninductive load.
TYPE OF RECEPTION: CW (unmodulated) or modulated at low frequencies.
INPUT IMPEDANCE: 50 ohms.
ELECTRICAL CHARACTERISTICS OF ANTENNA: Shielded loop, 11 turns, 30 inches, 375 microhenries inductance.
POWER SUPPLY
VOLTAGE: 105 to 125 v or 210 to 250 v rms.
PHASE: Single ph.

TUBE AND/OR CRYSTAL COMPLEMENT

(1) OA2	(1) OB2	(1) 6AL5
(2) 6AU6WA	(2) 6AQ5W	(3) 6C4W
(1) 6J6	(1) 5722	(8) 5725
(2) 5751	(3) 5879	

Total Tubes: (25)
No Crystals used.

REFERENCE DATA AND LITERATURE

NAVSHIPS 93119: Technical Manual for FIELD STRENGTH METER AN/URM-102(XN-1).

TYPE CLASSIFICATION (NAVY)
DESIGN COGNIZANCE USN, BUSHIPS
PROCUREMENT COGNIZANCE SPEC: SHIPS-M-2426
STOCK NO.
R.D.B. IDENT. NO. 5.6

SHIPPING DATA

NUMBER OF BOXES	CONTENTS AND IDENTIFICATION	VOLUME (Cu.Ft.)	OVERALL DIMENSIONS (inches)	WEIGHT PACKED (lbs.)
1	Field Strength Meter AN/URM-102(XN-1)	18.5	18 X 37 X 48	269

UNCLASSIFIED

January 1961

Test-Field Intensity Measuring

FIELD STRENGTH METER

AN/URM-102(XN-1)

EQUIPMENT SUPPLIED DATA

QUANTITY PER EQUIPT	NAME AND NOMENCLATURE	OVERALL DIMENSIONS (inches)	WEIGHT (lbs.)
1	Transit Case CY-2280(XN-1)/URM-102 includes:	11-1/2 X 22 X 23	24-1/2
1	Field Strength Meter IM-138(XN-1)/URM-102	9-1/2 X 18 X 19	48.5
1	Technical Manual NAVSHIPS 93119		
1	Chart, Calibration PT-431(XN-1)/URM-102		
1	Accessory Case CY-2281(XN-1)/URM-102 includes:	7-9/16 X 8-3/8 X 10-1/2	15.5
1	Headphones CADV #91439-1		
1	Special Purpose Cable Assy CADV #91487-1	120 lg	
1	Cable Assembly, Power CX-3810/U	72 lg	
1	Cable Assembly, RF CG-1669(XN-1)/URM-102	240 lg	
1	Special Purpose Cable Assy CG-573/U	36 lg	
1	Loop Antenna Case CY-2279(XN-1)/URM-102 includes:	5-1/2 X 33-3/4 X 33-3/4	30
1	Loop Antenna AT-206/URM-6	30 dia	4.5
1	Strap, Carrying CADV #90782-1		.5
1	Tripod Bag CY-709/URM-6 includes:	8-1/2 dia X 42-1/2	4.5
1	Tripod MT-674/U		11

UNCLASSIFIED

4.5 AN/URM-102(XN-1): 3

April 1959

Test-Field Intensity Measuring

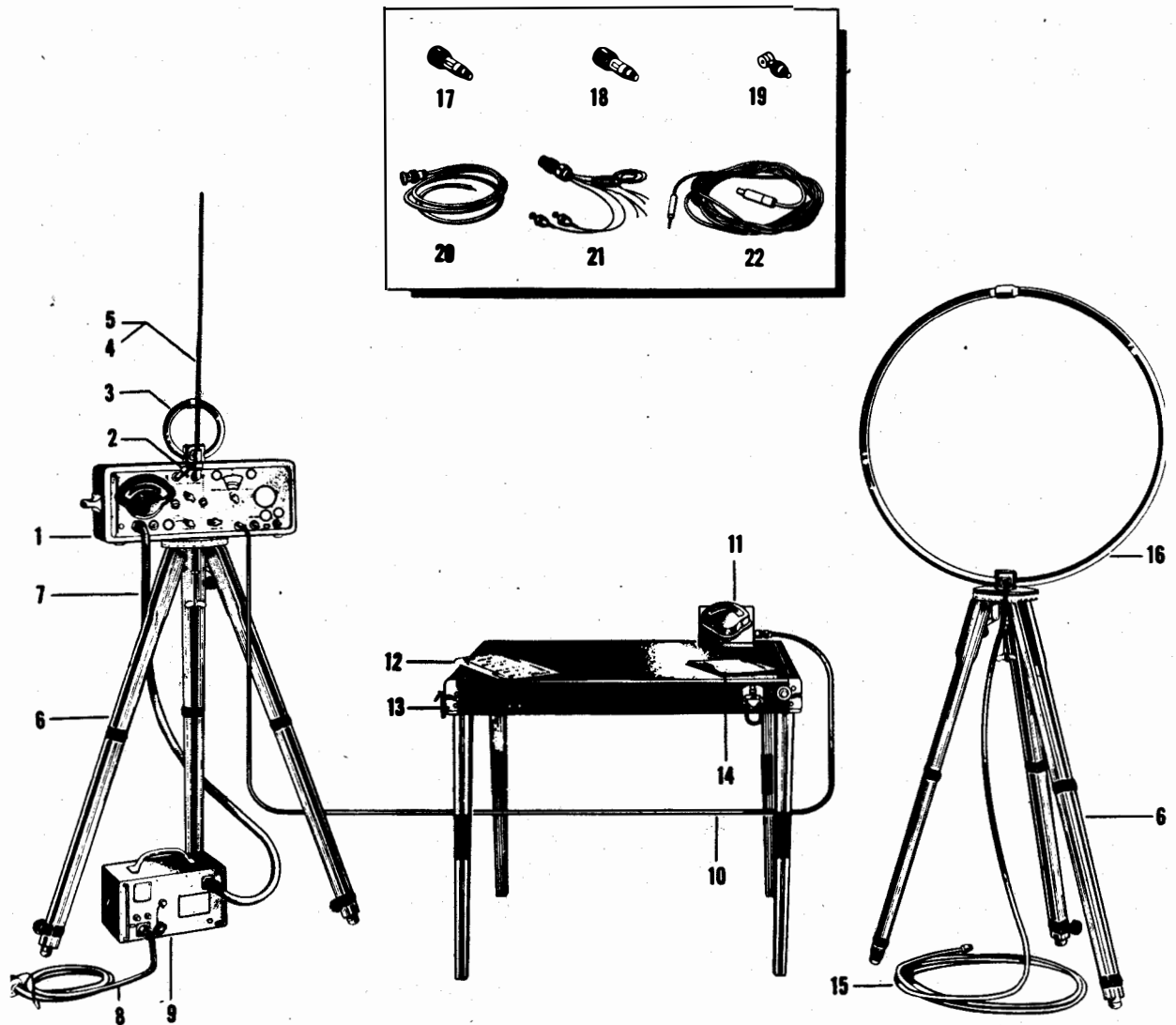
RADIO INTERFERENCE MEASURING SET**AN/URM-106**

- | | |
|---|---|
| 1 Radio Interference-Field Intensity Meter IM-36B/URM-6 | 12 Instruction Book |
| 2 RF Cable Assembly CG-577/URM-6 | 13 Top of Case CY-707/URM-6 |
| 3 Antenna AT-205/URM-6 | 14 Chart PT-107/URM-6 |
| 4 Antenna AT-203/URM-6 | 15 Cord CG-444/U |
| 5 Antenna AT-204/URM-6 | 16 Antenna AT-206/URM-6 |
| 6 Tripod MT-674/U | 17 Impedance Matching Network CU-184/URM-6 |
| 7 Special Purpose Cable Assembly 91487-1(10'0") | 18 Impedance Matching Network CU-186/URM-6 |
| 8 Power Cable Assembly CX-3810/U (6'0") | 19 Antenna AT-207/URM-6 |
| 9 Power Supply PP-449/URM-6 | 20 Special Purpose Cable Assembly CG-573/U (3'0") |
| 10 Special Purpose Cable Assembly CG-571/U (20'0") | 21 Special Purpose Cable Assembly CADV-62482 (2'0") |
| 11 Ammeter ME-31/U | 22 Special Purpose Cable Assembly CG-572/U (20'0") |

Radio Interference Measuring Set AN/URM-106

April 1959

Test-Field Intensity Measuring

AN/URM-106 RADIO INTERFERENCE MEASURING SET**FUNCTIONAL DESCRIPTION**

Radio Interference Measuring Set AN/URM-106 is a radio interference and field intensity meter used in radio signal or interference surveys, in determining the source of conducted or radiated signals, and in adjusting directive antennas or in the exploration of radiated fields. As a highly sensitive radio receiver, it operates as a selective rf voltmeter over a wide range of field intensity. It may be installed ashore, or aboard vessels, aircraft or vehicles. Application is in field and depot maintenance.

No field changes in effect at time of preparation (3 April 1959).

RELATION TO OTHER EQUIPMENT

This equipment is identical to Radio Test Set AN/URM-6B except for the omission of several units of equipment.

EQUIPMENT REQUIRED BUT NOT SUPPLIED

Batteries: (1) BA-2, (5) BA-26, (1) 6v-SBMD-175AH.

ELECTRICAL AND MECHANICAL CHARACTERISTICS**POWER REQUIREMENTS**

AC: 100 W, 105 to 125 v or 210 to 250 v, 50 to 1,600 cy, 1 ph.

DC: 6 v, 4.1 amp (fil); 67.5 v, 8 ma (bias); 225 v, 55 ma (plate).

FREQUENCY RANGE: 14 to 250 kc.

INTERMEDIATE FREQUENCY: 12.5 kc.

AUDIO IMPEDANCE: 600 ohms.

FIELD INTENSITY RANGE: 1 uv/meter to more than 10 v/meter, depending on ant. used.

IF REJECTION: 60 db or better.

IMAGE REJECTION: -50 db or better from sig level.

RECEIVER METER SCALE: 0 to 100 uv; 0 to 40 db.

SELECTIVITY: 6 db down at 100 cy at lower rf; 6 db down at 600 cy at higher rf; 60 db down for 2,000 cy at any rf.

SENSITIVITY: 1 uv (as a rm); 1 uv/meter (as field intensity meter); 10 uv/meter (w/short rod ant.)

AF SENSITIVITY: 10 uv for 100 mw output.

ACCURACY OF INTENSITY RANGE: $\pm 10\%$ (10 uv to 1 v).

MANUFACTURER'S OR CONTRACTOR'S DATA

Stoddart Aircraft Radio Co., Inc., Hollywood, California.

Contract NObsr-71831, 28 June 1957.

TUBE AND/OR CRYSTAL COMPLEMENT

(2) OC3	(1) 5Y3WGTA
(1) 6AL5	(1) 6AT6
(6) 6AU6	(1) 6BE6
(3) 6C4	(1) 6E5
(1) 6J6	(1) 6X4W
(1) NE2	(1) NE32

Total Tubes: (20)

No Crystals Used.

REFERENCE DATA AND LITERATURE

NAVSHIPS 93134: Technical Manual for Radio Interference Measuring Set AN/URM-106.

TYPE CLASSIFICATION
DESIGN COGNIZANCE BUSHIPS
PROCUREMENT COGNIZANCE SHIP-T-2666
STOCK NO.
R.D.B. IDENT. NO. 5.6

UNCLASSIFIED

April 1959

Test-Field Intensity Measuring

RADIO INTERFERENCE MEASURING SET**AN/URM-106****SHIPPING DATA**

NUMBER OF BOXES	CONTENTS AND IDENTIFICATION	VOLUME (Cu.Ft.)	OVERALL DIMENSIONS (inches)	WEIGHT PACKED (lbs.)
1	Radio Interference Measuring Set AN/URM-106	24.9	19-1/2 X 45-1/2 X 48-1/2	262

EQUIPMENT SUPPLIED DATA

QUANTITY PER EQUIPT	NAME AND NOMENCLATURE	OVERALL DIMENSIONS (inches)	WEIGHT (lbs.)
1	Radio Interference Measuring Set AN/URM-106 Incl:		187
1	Case CY-706/URM-6 Containing:		
1	Radio Interference Field Intensity Meter IM-368/URM-6	9-1/2 X 12-3/4 X 31-1/4	30
1	Power Supply PP-449/URM-6	8 X 10-3/8 X 19-13/16	26
1	Antenna AT-203/URM-6	7-31/32 X 9-29/32 X 19-3/4	24.75
1	Antenna AT-204/URM-6	53 lg	
1	Antenna AT-205/URM-6	86 lg	
1	Adapter UG-537/U	5-1/4 dia	
1	RF Cable Assy CG-577/URM-6		
1	Power Cable Assy CX-3810/U	72 lg	
1	Special Purpose Cable Assy 91487-1	120 lg	
1	Chart PT-435/URM-106		
2	Technical Manual NAVSHIPS 93134		
1	Case CY-707/URM-6 Containing:		
1	Ammeter ME-31/U	6 X 20 X 30	24
1	Antenna AT-207/URM-6	3/4 dia X 2 lg	
1	Impedance Matching Network CU-184/URM-6		
1	Impedance Matching Network CU-186/URM-6		
1	Cord CG-444/U	240 lg	
1	Special Purpose Cable Assy CG-571/U	240 lg	
1	Special Purpose Cable Assy CG-572/U	240 lg	
1	Special Purpose Cable Assy 62482	24 lg	
1	Special Purpose Cable Assy CG-573/U	36 lg	
1	Shoulder Strap		
1	Case CY-709/URM-6 Containing:		
2	Tripod MT-674/U	9 dia X 42 69 extended	5
1	Case CY-710/URM-6 Containing:		
1	Antenna AT-206/URM-6	5 X 34 X 34 30 dia	36
1	Shoulder Strap	1/8 X 2-1/2 X 74	

UNCLASSIFIED

4.5 AN/URM-106: 3

18 February 1963

RECEIVING SET PANORAMIC DATA AN/URM-126(XN-1)

Cog Service: USN FSN:

Functional Class: 5

USA

USN

USAF

TYPE CLASS:

Used by

MANUFACTURER'S NAME/CODE NUMBER: Motorola Incorporated, (80211).

(No Illustration Available)

FUNCTIONAL DESCRIPTION:

The AN/URM-126(XN-1) is a panoramic field intensity equipment covering the frequency range of 50 cycles per second to 100 kilocycle in 10 each 10-KC bands, for use in connection with electromagnetic wave propagation measurements and studies. This set is designed for general purpose use.

No field changes in effect at time of preparation (6 February 1963).

TECHNICAL CHARACTERISTICS:

TYPES OF EMISSION: A0, F0, P0 types.

TYPE OF RECORDING: Automatic 35 mm camera recording.

TYPE OF INJECTION: Continuous calibration signal injection.

TYPE OF RANGE INDICATED: 40-db dynamic range indicated.

EFFECTIVE BANDWIDTH: 15 cps.

SWEEP DATA

NUMBER OF SWEEPS: Up to 10.

SWEEP TIME: 1 sweep per minute.

FREQUENCY DATA

NUMBER OF BANDS: 10.

OPERATING FREQUENCY RANGE: 50 cps to 100 kc.

OPERATING POWER RQMT: 115 v ac or 230 v ac, 50 to 60 cps, single ph.

RELATION TO OTHER EQUIPMENT: None.

EQUIPMENT REQUIRED BUT NOT SUPPLIED: None.

MAJOR COMPONENTS

QTY	ITEM	STOCK NUMBERS	DIMENSIONS (INCHES)	WEIGHT (LBS)
1	Receiving Set, Panoramic Data AN/URM-126(XN-1) consists of:			
1	Power Supply Unit-1			
1	Radio Receiver Unit-2			
1	Antenna Coupler Unit-3			

4.5 AN/URM-126(XN-1): 1

AN/URM-126(XN-1) RECEIVING SET PANORAMIC DATA

REFERENCE DATA AND LITERATURE:

TUBE, CRYSTAL AND/OR SEMI-CONDUCTOR DATA:

TUBES: Data not available.

CRYSTALS: Data not available.

SEMI-CONDUCTORS: Data not available.

SHIPPING DATA

PKGS	VOLUME (CU FT)	WEIGHT (LBS)
------	----------------	--------------

PROCUREMENT DATA

PROCURING SERVICE: USN

DESIGN COG: USN, BuShips

SPEC &/OR DWG: SHIPS-P-3258

CONTRACTOR	LOCATION	CONTRACT OR ORDER NO.	APPROX. UNIT COST
Motorola Incorporated, Pt no. 201-32938	Phoenix, Arizona	N0bsr-77543 (FBM), 10 March 1959	

4 April 1962

RADIO INTERFERENCE MEASURING SET AN/URM-138()

Cog Service:

FSN:

Functional Class:

USA

USN

USAF

TYPE CLASS:

MANUFACTURER'S NAME/CODE NUMBER: Stoddart Aircraft Radio Co., Incorporated.

(No Illustration Available)

FUNCTIONAL DESCRIPTION:

The Radio Interference Measuring Set AN/URM-138() is a self-contained, portable, measuring set, for general purpose use. It is designed to make quantitative measurements of radiated and/or conductive broad-band and/or carrier radio-frequency interference.

No field changes in effect at time of preparation (7 June 1961).

TECHNICAL CHARACTERISTICS:

METHOD OF MOUNTING: Portable and/or bench-mounted.

OPERATING FREQUENCY RANGE: 1 to 10k mc.

NUMBER OF BANDS: 4 bands.

TYPE OF CALIBRATION: Meter type.

TYPE OF CALIBRATION: In uv and db scales.

SCALE RANGES: 1 to 100 uv; 0 to 40 db.

ACCURACY: Form 1%.

TYPE OF INDICATION: Visual null neon lamp indication.

INPUT IMPEDANCE: 50 ohms.

OPERATING POWER RQMT: 115 v, 230 v ac, 50 to 60 cps, single ph.

RELATION TO OTHER EQUIPMENT: None.

EQUIPMENT REQUIRED BUT NOT SUPPLIED: None.

MAJOR COMPONENTS

QTY	ITEM	STOCK NUMBERS	DIMENSIONS (INCHES)	WEIGHT (LBS)
1	Radio Interference Measuring Set AN/URM-138() consists of:			
1	Carrying Case		23-1/2 x 24 x 28	
1	Antenna (Broadband)			
1	Antenna Horn (1.0 to 2.5k mc)			
1	Antenna Horn (2.5 to 4.4k mc)			
1	Antenna Horn (4.4 to 7.0k mc)			
1	Antenna Horn (7.0 to 10k mc)			
1	Parabolic Reflector			
1	Tripod			
1	Cable Ass'y Radio Frequency			

4.5 AN/URM-138(): 1

AN/URM-138() RADIO INTERFERENCE MEASURING SET

QTY	ITEM	STOCK NUMBERS	DIMENSIONS (INCHES)	WEIGHT (LBS)
1	Antenna Mast Type AB-189/URM-()			
1	Headphone Type H-132/U			
1	Cable Ass'y Radio Frequency Type CG-573/U			
1	Cable Ass'y Power Type CX-3810/U			
1	Meter Remote Type ME-()/U			
1	Cable Ass'y Radio Frequency Type CG-572/U (20 ft)		240 1g	
1	Bag, Tripod			
1	Case, Antenna			
1	Case, Antenna			
1	Case, Accessory			

REFERENCE DATA AND LITERATURE:

Nomenclature Card for Radio Interference Measuring Set AN/URM-138().

TUBE, CRYSTAL AND/OR SEMI-CONDUCTOR DATA:

TUBES: Data not available.

CRYSTALS: Data not available.

SEMI-CONDUCTORS: Data not available.

SHIPPING DATA

PKGS	VOLUME (CU FT)	WEIGHT (LBS)
------	----------------	--------------

PROCUREMENT DATA

PROCURING SERVICE:

DESIGN COG: USN, BuShips

SPEC &/OR DWG: MIL-M-16616

CONTRACTOR	LOCATION	CONTRACT OR ORDER NO.	APPROX. UNIT COST
Stoddart Aircraft Radio Co., Incorporated Model no. NM-60(XN-2)	Hollywood, (38) California	N0bsr-81138	

4.5 AN/URM-138(): 2

RADIO TEST SET

AN/URM-17, -17A

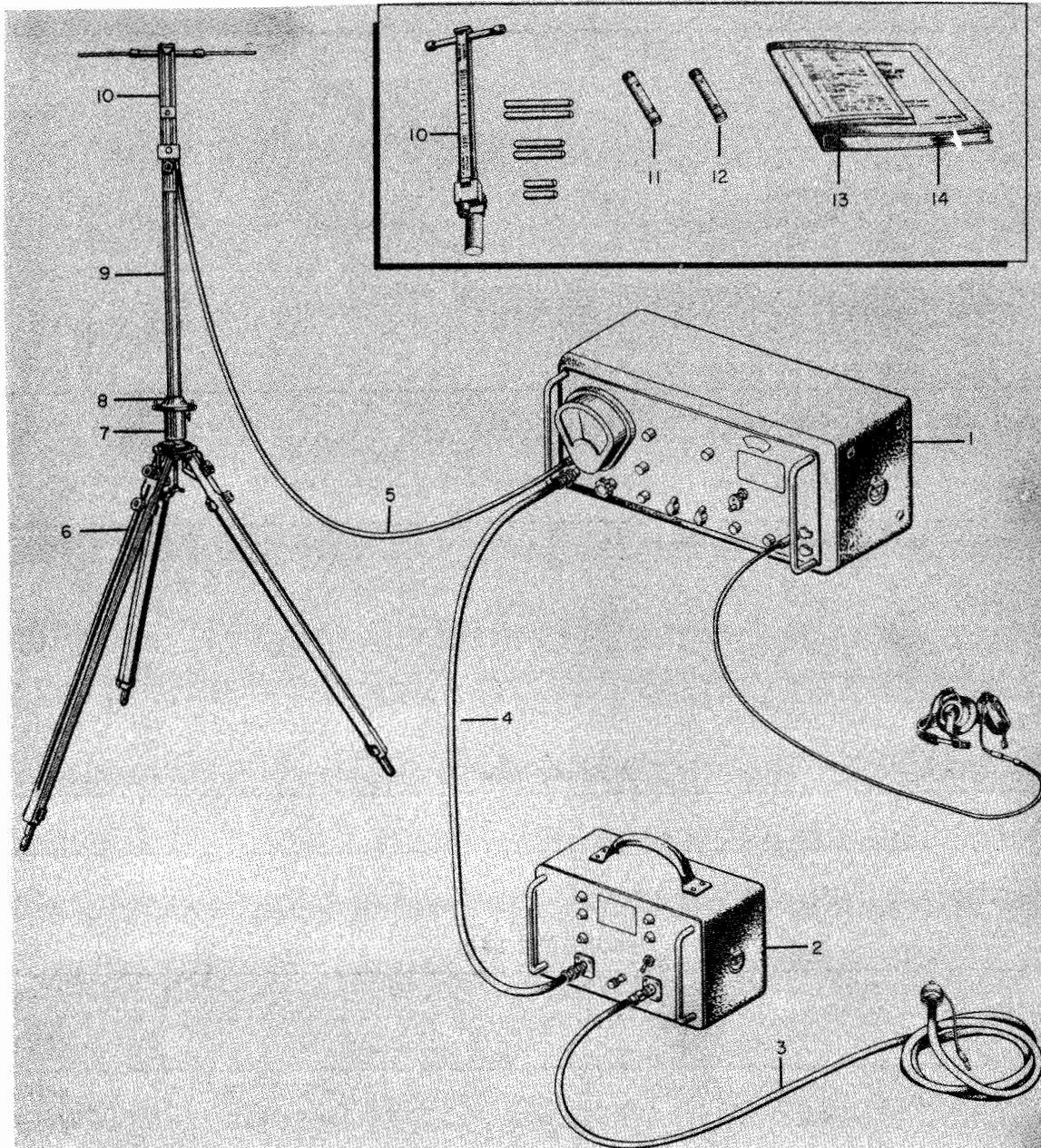

- | | |
|--|---|
| 1. Radio Interference-Field Intensity Meter IM-52/URM-17 | 8. Azimuth Dial Pointer Assembly CADV-90045-1 |
| 2. Power Supply PP-530/URM-17 | 9. Antenna Mast Section AB-189/URM-17 |
| 3. Power Cable Assembly CADV-62480 (6' 0") | 10. Antenna AT-255/URM-17 |
| 4. Special Purpose Cable Assembly CADV-62481 (10' 0") | 11. R.F. Probe DT-56/URM-17 |
| 5. R.F. Cable Assembly CG-678/U (20' 0") | 12. Impedance Matching Network CU-227/URM-17 |
| 6. Tripod CADV-10545 | 13. Chart Set PT-210/URM-17 |
| 7. Azimuth Dial Assembly CADV-90044-1 | 14. Instruction Book |

Radio Test Set AN/URM-17-17A

April 1958

Test-Field Intensity Measuring

AN/URM-17, -17A**RADIO TEST SET****FUNCTIONAL DESCRIPTION**

The AN/URM-17 and AN/URM-17A are radio interference and field intensity measuring equipment designed for field use.

They are sensitive radio receivers which can be used as a sensitive selective radio frequency voltmeters over the 375 to 1000 mc band.

They are used for radio interference, surveys to determine the source and magnetude of radiated or conducted interference, for adjusting directive antennas or for exploring radiation fields, where their intensity may vary over a wide range of values. It is designed for use aboard vessels, aircraft, vehicles or at shore stations.

The AN/URM-17A differs from the AN/URM-17 in design changes of components.

No field changes in effect at time of preparation (20 Mar 1958).

RELATION TO OTHER EQUIPMENT

The AN/URM-17 is similar to Stoddart NM-50 A. These sets are frequently used with a headphone set such as Navy Type 49509 for aural monitoring and w/observer compass Mark I Mod O, for alignment of dipole antennas.

ELECTRICAL AND MECHANICAL CHARACTERISTICS

FREQUENCY RANGE: 375 to 1000 mc.

INPUT IMPEDANCE: 50 ohms.

SELECTIVITY

AT 1000 MC: 3 db down for 1.8 mc band width; 60 db down for 4.5 mc band width.

AT 370 MC: 3 db down for 1.0 mc band width; 60 db down for 3.0 mc band width.

IMAGE REJECTION: 40 db or better.

SPURIOUS RESPONSE REJECTION: 40 db or better.

IF REJECTION: 60 db or better; 60 mc IF.

SENSITIVITY

AS AN RF VOLTMETER: 10 uv.

AS A FIELD INTENSITY METER: 100 to 350 uv per meter depending on frequency.

AUDIO OUTPUT: 100 mw min for 600 ohm load.

POWER SOURCE REQUIRED

AC OPERATION: 105 to 125 v/210 to 250 v. 50 to 1600 cps, 110 W.

DC OPERATION: 6.3 v DC, 3.4 amp ((1) 6 v-SBMD-175AH battery); 225 v DC, 99 milliampere ((5) JAN-BA26, NAVY-19004A battery); 22.5 v DC, 6.9 milliampere ((1) JAN-BA2, NAVY-19033 battery).

MANUFACTURER'S OR CONTRACTOR'S DATA

Stoddart Aircraft Radio Co, Hollywood, Calif.

Contract: NObsr-42430, dated 30 June 1948. (AN/URM-17).

Contract: NObsr-71806, dated 29 May 1957. (AN/USM-17A).

TUBE AND/OR CRYSTAL COMPLEMENT**AN/URM-17**

(1) 12AU7	(1) 6AR5
(8) 6BH6	(2) 6F4
(2) 5726/6AL5W	(1) 6AS7G
(2) 6C4WA	(1) 9005

Total Tubes: (18)

AN/URM-17A

(2) 5726/6AL5	(1) 6080WA/6AS7G
(2) 6135/6C4	(1) 5651
(1) 5814/12AU7	(8) 6BH6
(1) 6AR5	(1) 9005
(2) 6F4	(1) GL-6299

Total Tubes: (20)

(1) 1N21B*

Total Crystals: (1)

*Note: 1 each for AN/URM-17 and -17A.

REFERENCE DATA AND LITERATURE

NAVSHIPS 91388, Technical Manual for Radio Test Set AN/URM-17.

NAVSHIPS 93083A, Technical Manual for Radio Interference Measuring Set AN/URM-17A.

TYPE CLASSIFICATION

DESIGN COGNIZANCE BUSHIPS

PROCUREMENT COGNIZANCE

STOCK NO.

R.D.B. IDENT. NO.

SHIPPING DATA

NUMBER OF BOXES	CONTENTS AND IDENTIFICATION	VOLUME (Cu.Ft.)	OVERALL DIMENSIONS (inches)	WEIGHT PACKED (lbs.)
1	Radio Test Set AN/URM-17 or	8.3	18-1/4 x 43-1/2 x 19	170
1	Radio Test Set AN/URM-17A	10.9	17-1/4 x 21-1/4 x 47	220

RADIO TEST SET

AN/URM-17, -17A

EQUIPMENT SUPPLIED DATA

QUANTITY PER EQUIPT	NAME AND NOMENCLATURE	OVERALL DIMENSIONS (inches)	WEIGHT (lbs.)
1	Case CY-866/URM-17	10-7/8 x 16-1/4 x 23-3/4	25
1	Radio Interference-Field Intensity Meter IM-52/URM-17* or IM-52A/URM**	9-3/16 x 10-3/8 x 19-13/16	30
1	Chart Set PT-210/URM-17* or PT-430/URM-17A		
1	Headphones H3/ARR-3* or H-132/U**		
2	Technical Manuals NAVSHIPS 91388* or NAVSHIPS 93083A**		
1	Case (Accessory) CY-865/URM-17* or CY-2266/URM-17A**	10-1/8 x 14-5/8 x 15-1/2	17
1	Power Supply PP-530/URM-17* or PP-530A/URM-17**	10-3/4 x 15-5/8 x 18-3/8	17
1	Antenna AT-255/URM-17* or AT-792/URM-17**	7-31/32 x 9-29/32 x 19-3/4	16
1	RF Probe DT-56/URM-17* or DT-194/URM-17A**		
1	Impedance Matching Network CU-227/URM-17*		
	Interconnecting Cables, Accessories and associated hardware.		

NOTES: *Supplied w/AN/URM-17 only.
 **Supplied w/AN/URM-17A only.

13 February 1963

Cog Service: USN

FSN: F6625-649-2233

RADIO INTERFERENCE MEASURING SET AN/URM-47

Functional Class: 5.6

USA

USN

USAF

TYPE CLASS:

Used by

MANUFACTURER'S NAME/CODE NUMBER: Stoddart Aircraft Radio Co., Inc., (78591).

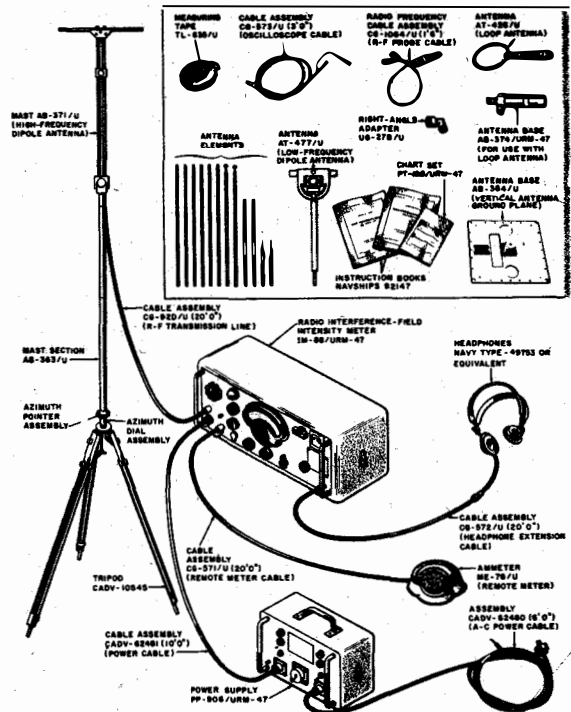

Radio Interference Measuring Set AN/URM-47

FUNCTIONAL DESCRIPTION:

Radio Interference Measuring Set AN/URM-47 is a highly sensitive hf and VHF superheterodyne receiver and meter with calibrated tuned dipole antenna. Locates and measures rf interference (noise); makes field intensity measurements; used for radio interference surveys, adjusting directive antennas, exploring radiation patterns.

Data on this sheet reflects the following field changes: F.C. #1.

TECHNICAL CHARACTERISTICS:

FREQUENCY RANGE: 20 to 400 mc.

BAND DATA

BAND 1: 20 to 33 mc.

BAND 2: 33 to 54 mc.

BAND 3: 54 to 88 mc.

AN/URM-47 RADIO INTERFERENCE MEASURING SET

BAND 4: 88 to 145 mc.

BAND 5: 145 to 250 mc.

BAND 6: 240 to 400 mc.

TYPE OF RECEIVER: Superheterodyne.

INTERMEDIATE FREQUENCY: 15 mc.

SENSITIVITY: Radiated pickup using a calibrated, tuned dipole (less reflector), one to 60 microvolts-per-meter, depending on frequency used. Conducted pickup via a 50 ohm matched coaxial line, one microvolt from 20 to 240 mc, five microvolts from 240 to 400 mc.

SELECTIVITY: 138 to 175 kc wide throughout entire range, at 6 db down from signal level.

ACCURACY: Form 15% at signal levels above 10 microvolts.

SPURIOUS RESPONSE REJECTION: Better than 40 db.

IF REJECTION: Greater than 60 db.

AUDIO OUTPUT: More than 100 milliwatts into a 600 ohm, non-inductive load based on an output meter indication of 10 microvolts and rf signal input modulated 30%, 1000 cps.

OSCILLOSCOPE OUTPUT: Frequency response flat within 3 db from 20 to 100,000 cps depending on load.

DYNAMIC RANGE: M20 db form 2 db at full scale.

EFFECTIVE RANDOM NOISE BANDWIDTH: Varies between 110 and 150 kc, depending upon frequency.

TYPE OF RECEPTION: Carrier, modulated carrier, pulse, or radio interference.

INPUT IMPEDANCE: 50 ohms (coaxial), provision for matched attenuation incorporated with receiver.

SHIELDING: 60 db or better.

ANTENNA: Calibrated tuned dipole.

POWER SUPPLY

VOLTAGE: 105 to 125 v rms, or 210 to 250 v rms,

PHASE: Single.

FREQUENCY: 50 to 1000 cps.

POWER: Approx. 150 W at 115 v, 60 cyc.

RELATION TO OTHER EQUIPMENT:

This equipment replaces Noise Field Intensity Meter TS-587/U and TS-587A/U. The AN/URM-47 is also similar to Radio Test Set AN/PRM-1, Radio Test Set AN/URM-6, 6 Band Radio Test Set AN/URM-17, except it differs in frequency band of operation.

EQUIPMENT REQUIRED BUT NOT SUPPLIED: None.

MAJOR COMPONENTS

QTY	ITEM	STOCK NUMBERS	DIMENSIONS (INCHES)	WEIGHT (LBS)
1	Radio Interference Measuring Set AN/URM-47 includes:			
1	Test Set Case CY-1527/URM-47 containing:		11-5/16 x 13-1/2 x 23-3/4	50
1	Radio Interference-Field Intensity Meter IM-88/URM-47		7-5/8 x 10-3/8 x 19-13/16	

4.5 AN/URM-47: 2

RADIO INTERFERENCE MEASURING SET AN/URM-47

QTY	ITEMS	STOCK NUMBERS	DIMENSIONS (INCHES)	WEIGHT (LBS)
1*	Headphones NT-49753 or equivalent			
2	Chart Set PT-188/URM-47			
2	Technical Manual NAVSHIPS 92147(A)		1/2 x 8-1/2 x 11	
1	Accessories Case CY-1525/URM-47 containing:		10-5/8 x 15-1/2 x 16-1/8	46
1	Power Supply PP-906/URM-47		7-17/32 x 8-3/8 x 10-1/2	
1	Ammeter ME-76/U			
1	Antenna Base AB-364/U			
1	RF Cable Assy CG-1064/U		18 lg	
1	Assembly NT-62480		72 lg	
1	Cable Assy CG-573/U		36 lg	
1	Cable Assy CG-572/U		240 lg	
1	Cable Assy CG-571/U		240 lg	
1	Cable Assy NT-62481		120 lg	
1	Cable Assy CG-92D/U		240 lg	
1	Antenna Case CY-1526/URM-47 containing:		10 x 10-1/2 x 40-1/2	36
1	Mast AB-371/U			
1	Antenna AT-477/U			
2	Mast Section AB-363/U			
1	Tripod NT-10545			
1	Antenna AT-426/U			
1	Antenna Base AB-374/URM-47			
1	Measuring Tape TL-635/U			
1	Right-Angle Adapter UG-27B/U			
1	Azimuth Dial Assy			
1	Azimuth Pointer Assy			
1 set	Antenna Elements			

*Govt furnished equipment.

REFERENCE DATA AND LITERATURE:

NAVSHIPS 92147(A): Technical Manual for Radio Interference Measuring Set AN/URM-47.

TUBE, CRYSTAL AND/OR SEMI-CONDUCTOR DATA:

TUBES: (1) 0A2 (1) 0B2 (1) 5R4GY (1) 5651 (1) 5718 (1) 5726 (2) 5814 (4) 5840
(2) 6AU6WA/6AU6 (6) 6BH6 (1) 6005/6AQ5 (1) 6080 (4) 6135

CRYSTALS: None used.

SEMI-CONDUCTORS: (1) 1N63

AN/URM-47 RADIO INTERFERENCE MEASURING SET

SHIPPING DATA

PKGS	VOLUME (CU FT)	WEIGHT (LBS)
1	13.9	212

PROCUREMENT DATA

PROCURING SERVICE: USN

DESIGN COG: USN, BuShips

SPEC &/OR DWG: MIL-R-15683A(SHIPS)

CONTRACTOR	LOCATION	CONTRACT OR ORDER NO.	APPROX. UNIT COST
Stoddart Aircraft Radio Co., Inc.	Hollywood, Calif.	N0bsr-52301, 26 March 1951	\$3,718.47
		N0bsr-64089, 15 December 1953	3,749.92
		N0bsr-71189	

13 February 1963
Cog Service: USN FSN:

RADIO INTERFERENCE MEASURING SET AN/URM-47A
Functional Class: 5.6

USA

USN

USAF

TYPE CLASS:

Used by

MANUFACTURER'S NAME/CODE NUMBER: Stoddart Aircraft Radio Co., Inc., (78591).

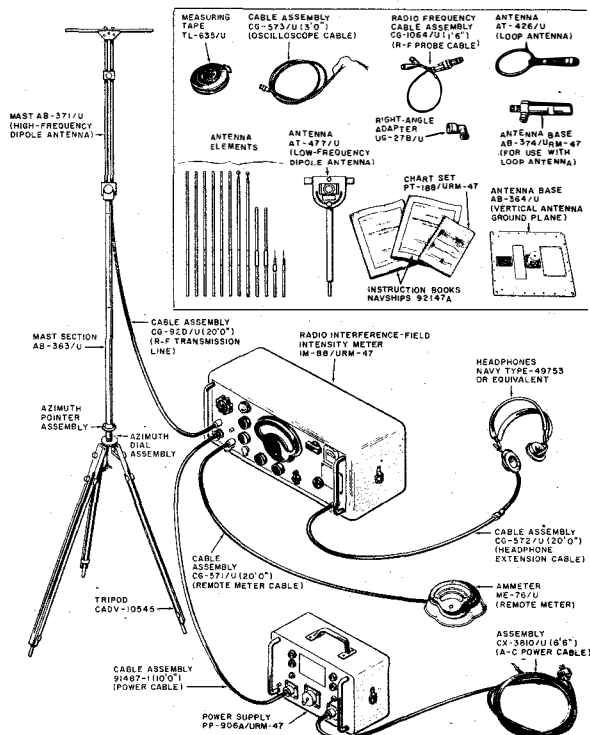

Radio Interference Measuring Set AN/URM-47A

FUNCTIONAL DESCRIPTION:

Radio Interference Measuring Set AN/URM-47A is a highly sensitive hf and VHF superheterodyne receiver and meter with calibrated tuned dipole antenna. Locates and measures rf interference (noise); makes field intensity measurements; used for radio interference surveys, adjusting directive antennas, exploring radiation patterns.

No field changes in effect at time of preparation (29 November 1962).

TECHNICAL CHARACTERISTICS:

FREQUENCY RANGE: 20 to 400 mc.

BAND DATA

BAND 1: 20 to 33 mc.
BAND 2: 33 to 54 mc.
BAND 3: 54 to 88 mc.

AN/URM-47A RADIO INTERFERENCE MEASURING SET

BAND 4: 88 to 145 mc.

BAND 5: 145 to 250 mc.

BAND 6: 240 to 400 mc.

TYPE OF RECEIVER: Superheterodyne.

INTERMEDIATE FREQUENCY: 15 mc.

SENSITIVITY: Radiated pick-up using a calibrated, tuned dipole (less reflector), one to 60 microvolts-per-meter, depending on frequency used. Conducted pick-up via a 50 ohm matched coaxial line, on microvolt from 20 to 145 mc, two microvolts from 145 to 240 mc, seven microvolts from 240 to 400 mc.

ACCURACY: Porm 15% at signal levels above 10 microvolts.

SPURIOUS RESPONSE REJECTION: Better than 40 db.

IF REJECTION: Greater than 60 db.

AUDIO OUTPUT: More than 100 milliwatts into a 600 ohm, non-inductive load based on an output meter indication of 10 microvolts and rf signal input modulated 30%, 1000 cps.

OSCILLOSCOPE OUTPUT: Frequency response flat within 3 db from 20 to 100000 cps depending on load.

DYNAMIC RANGE: M20 db porm 2 db at full scale.

EFFECTIVE RANDOM NOISE BANDWIDTH: Varies between 110 and 150 kc, depending on frequency.

TYPE OF RECEPTION: Carrier, modulated carrier, pulse or radio interference.

INPUT IMPEDANCE: 50 ohms (coaxial); provision for matched attenuation incorporated with receiver.

SHIELDING: 60 db or better.

ANTENNA: Calibrated tuned dipole.

POWER SUPPLY

VOLTAGE: 105 to 125 v rms, or 210 to 250 v rms.,

PHASE: Single.

FREQUENCY: 50 to 60 cyc or 400 cyc.

POWER: Approx 115 W at 115 v, 60 cyc.

RELATION TO OTHER EQUIPMENT: None.

EQUIPMENT REQUIRED BUT NOT SUPPLIED: None.

MAJOR COMPONENTS

QTY	ITEM	STOCK NUMBERS	DIMENSIONS (INCHES)	WEIGHT (LBS)
1	Radio Interference Measuring Set AN/URM-47A includes:			
1	Test Set Case CY-1527/URM-47 containing:		11-5/16 x 13-1/2 x 23-3/4	50
1	Radio Interference-Field Intensity Meter IM-88/URM-47		7-5/8 x 10-3/8 x 19-13/16	
1*	Headphones NT-49753 or equivalent			
2	Chart Set PT-188/URM-47			

4.5 AN/URM-47A: 2

RADIO INTERFERENCE MEASURING SET AN/URM-47A

QTY	ITEMS	STOCK NUMBERS	DIMENSIONS (INCHES)	WEIGHT (LBS)
2	Technical Manual NAVSHIPS 93147		1/2 x 8-1/2 x 11	
1	Accessories Case CY-1525/URM-47 containing:		10-5/8 x 15-1/2 x 16-1/8	46
1	Power Supply PP-906A/URM-47		7-17/32 x 8-3/8 x 10-1/2	
1	Ammeter ME-76/U			
1	Antenna Base AB-364/U			
1	RF Cable Assy CG-1064/U		18 lg	
1	Assembly CX-3810/U		7B lg	
1	Cable Assy CG-573/U		36 lg	
1	Cable Assy CG-572/U		240 lg	
1	Cable Assy CG-571/U		240 lg	
1	Cable Assy CADV no. 91487-1		120 lg	
1	Cable Assy CG-92D/U		240 lg	
1	Antenna Case CY-1526/URM-47 containing:		10 x 10-1/2 x 40-1/2	36
1	Mast AB-371/U			
1	Antenna AT-477/U			
2	Mast Section AB-363/U			
1	Tripod NT-10545			
1	Antenna AT-426/U			
1	Antenna Base AB-374/URM-47			
1	Measuring Tape TL-635/U			
1	Right-Angle Adapter UG-27B/U			
1	Azimuth Dial Assy			
1	Azimuth Pointer Assy			
1 set	Antenna Elements			

*Govt furnished equipment.

REFERENCE DATA AND LITERATURE:

NAVSHIPS 93147: Technical Manual for Radio Interference Measuring Set AN/URM-47A.

TUBE, CRYSTAL AND/OR SEMI-CONDUCTOR DATA:

TUBES: (1) 0A2WA (1) 0B2WA (1) 5718 (1) 5726/6AL5W (2) 5814A (4) 5840
(1) 6AU6WA/6AU6 (6) 6BH6 (4) 6C4 (1) 6005/6AQ5

CRYSTALS: None used.

SEMI-CONDUCTORS: (1) 1N63

AN/URM-47A RADIO INTERFERENCE MEASURING SET

SHIPPING DATA

PKGS	VOLUME (CU FT)	WEIGHT (LBS)
1	13.9	215

PROCUREMENT DATA

PROCURING SERVICE: USN

DESIGN COG: USN, BuShips

SPEC &/OR DWG: SHIPS-1-2668, Amend 1

CONTRACTOR	LOCATION	CONTRACT OR ORDER NO.	APPROX. UNIT COST
Stoddart Aircraft Radio Co., Inc.	Hollywood, Calif.	N0bsr-71848, 28 June 1957	\$4,805.51

13 February 1963
Cog Service: USN

FSN:

RADIO INTERFERENCE MEASURING SET AN/URM-47B
Functional Class: 5.6

USA

USN

USAF

TYPE CLASS:

Used by

MANUFACTURER'S NAME/CODE NUMBER: Stoddart Aircraft Radio Co., Inc. (78591).

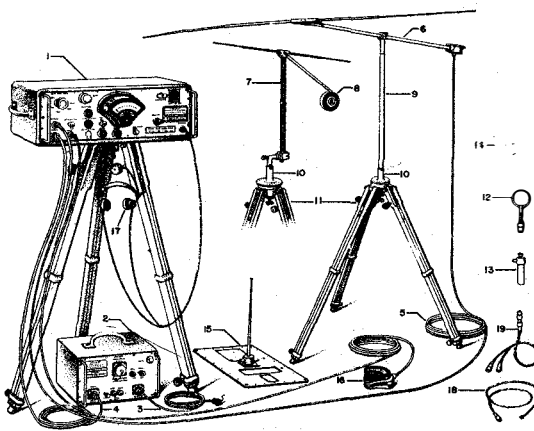

Item Number	Description
1	90786-2 Hi-XOA Hi-FI Meter (20-400 Mc).
2	91226-1 Power Supply
3	91228-1 A.C. Power Cable, 6 ft.
4	91287-1 Tower Supply Cable, 10 ft.
5	90933-1 HF Transmission Line, 20 ft.
6	91685-2 Dipole Antenna, Low Frequency (20-88 Mc).
7	91670-2 Dipole Antenna, High Frequency (88-400 Mc).
8	10645 Measuring Tape, Frequency
9	90920-2 Antenna Mast
10	91932-2 Antenna Mounting Adapter
11	91933-2 Collapsible Tripod (See Note 1).
12	90798-2 Loop Antenna
13	90991-2 Loop Antenna Base

Item Number	Description
14	91350-1 HF Current Probe
15	91972-2 Ground Plane Vertical Antenna
16	90934-2 Remote Meter
17	10794 Hi-FI Headphones
18	90911-1 Oscilloscope Cable, 3 ft.
19	90757-2 HF Probe Cable, 18 in.
20	90975-2 Remote Meter Cable, 20 ft.
21	*90074-1 Headphone Extension Cable
22	*90922-2 Transit Case
23	*90923-4 Accessory Case
24	*91934-2 Tripod Bag
25	*91971-2 Antenna Bag
26	*91981-2 Cable Bag
27	*91987-1 Millimeter Recorder
28	*90075-1 Recorder Cable, 6 ft.
29	*90076-10 Remote Meter, Slow-Speed

Note 1: Item (11) may be used to support either the Hi-XOA or antenna.
* Items not shown.
* Three recorder models are available.
Items shown in Figure 1-4.

Radio Interference Measuring Set AN/URM-47B

FUNCTIONAL DESCRIPTION:

Radio Interference Measuring Set AN/URM-47B is a highly sensitive hf and VHF superheterodyne receiver and meter with calibrated tuned dipole antenna. Locates and measures rf interference (noise); makes field intensity measurements; used for radio interference surveys, adjusting directive antennas, exploring radiation patterns.

No field changes in effect at time of preparation (29 November 1962).

TECHNICAL CHARACTERISTICS:

FREQUENCY RANGE: 20 to 400 mc.

BAND DATA

- BAND 1: 20 to 33 mc.
- BAND 2: 33 to 54 mc.
- BAND 3: 54 to 88 mc.

AN/URM-47B RADIO INTERFERENCE MEASURING SET

BAND 4: 88 to 145 mc.

BAND 5: 145 to 240 mc.

BAND 6: 240 to 400 mc.

TYPE OF RECEIVER: Superheterodyne.

INTERMEDIATE FREQUENCY: 15 mc.

SPURIOUS RESPONSE REJECTION: Image rejection better than 40 db; rejection to all other spurious responses, better than 60 db.

IF REJECTION: 80 db.

INPUT IMPEDANCE: 50 ohms (coaxial).

POWER SUPPLY

VOLTAGE: 105 to 125 v rms or 210 to 250 v rms.

PHASE: Single.

FREQUENCY: 50 to 60 cyc or 400 cyc.

POWER: Approx 115 W at 115 v, 60 cyc.

RELATION TO OTHER EQUIPMENT: None.

EQUIPMENT REQUIRED BUT NOT SUPPLIED: None.

MAJOR COMPONENTS

QTY	ITEM	STOCK NUMBERS	DIMENSIONS (INCHES)	WEIGHT (LBS)
1	Radio Interference Measuring Set AN/URM-47B includes:			
1	Test Set Case containing:			
1	Radio Interference-Field Intensity Meter			
1	Headphones			
2	Chart Set			
2	Technical Manual NAVSHIPS 93633		1/2 x 8-1/2 x 11	
1	Accessories Case containing:			
1	Power Supply			
1	Ammeter			
1	Antenna Base			
1	RF Cable Assy			
1	Assembly		72 lg	
1	Cable Assy CG-573/U		36 lg	
1	Cable Assy CG-572/U			
1	Cable Assy CG-571/U		72 lg	
1	Cable Assy		240 lg	
1	Cable Assy CG-92D/U		240 lg	
1	Antenna Case containing:			
1	Mast			
1	Antenna			
1	Mast Section			
1	Tripod			

4.5 AN/URM-47B: 2

RADIO INTERFERENCE MEASURING SET AN/URM-47B

QTY	ITEM	STOCK NUMBERS	DIMENSIONS (INCHES)	WEIGHT (LBS)
1	Antenna			
1	Antenna Base			
1	Measuring Tape			

REFERENCE DATA AND LITERATURE:

NAVSHIPS 93633: Technical Manual for Radio Interference Measuring Set AN/URM-47B.

TUBE, CRYSTAL AND/OR SEMI-CONDUCTOR DATA:

TUBES: (1) 0A2 (1) 0B2WA (1) 5718 (1) 5726 (2) 5814 (4) 5840 (1) 6AU6WA
(6) 6BH6 (1) 6005/6AQ5 (4) 6135

CRYSTALS: None used.

SEMI-CONDUCTORS: (1) 1N63

SHIPPING DATA

PKGS	VOLUME (CU FT)	WEIGHT (LBS)
1		

PROCUREMENT DATA

PROCURING SERVICE: USN
SPEC &/OR DWG:

DESIGN COG: USN, BuShips

CONTRACTOR	LOCATION	CONTRACT OR ORDER NO.	APPROX. UNIT COST
Stoddart Aircraft Radio Co., Inc., Model no. NM-30A	Hollywood, Calif.	NObsr-81571	\$4,309.00

April 1958

Test-Field Intensity Measuring

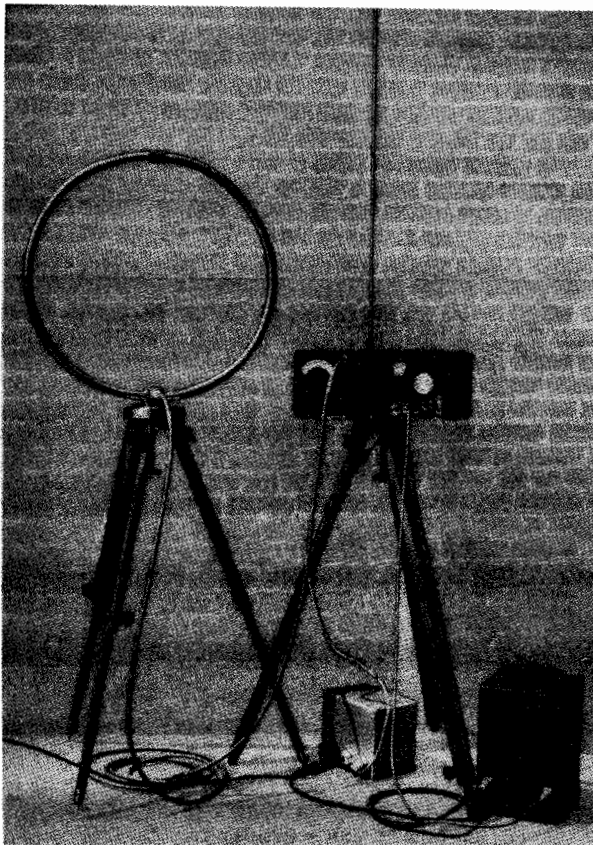
RADIO TEST SET**AN/URM-6**

Radio Test Set AN/URM-6

FUNCTIONAL DESCRIPTION

The AN/URM-6 is a radio-interference and field-intensity meter designed for field use, and operates within the 14 to 250 kilocycle band. It is a highly sensitive radio receiver which can be used as a selective RF voltmeter over a wide range of field intensity. It can be used for radio signal or interference survey, to determine the source of conducted or radiated signals, to adjust directive antennas, or explore radiation patterns. It is intended for installation ashore, aboard vessels, aircraft or vehicles.

An oscilloscope is sometimes used with the equipment for visual monitoring purposes.

No field changes in effect at time of preparation (11 April 1958).

RELATION TO OTHER EQUIPMENT

Equipment Required but not Supplied:
When using the test set in the field, Batter-

ies (1) NT-6v-SBMD-175AH for filaments, (5) JAN-BA-26 for plates, and (1) JAN-BA-26 and (1) JAN-BA-2 for bias, is required.

ELECTRICAL AND MECHANICAL CHARACTERISTICS

FREQUENCY RANGE: 14 to 250 kc.
SELECTIVITY: 6 db down at 100 cps, at lower radio frequency. 6 db down at 600 cps, at higher radio frequency. 60 db down for 2000 cps at any radio frequency.

SENSITIVITY

AS A VOLTMETER: 1 uv.

AS A FIELD INTENSITY METER: 1 uv/meter.

USING SHORT-ROD ANTENNA: 10 uv/meter.

RF SENSITIVITY: 10 uv for 100 mw output.

ACCURACY: $\pm 10\%$ from 10 uv/meter to 1 v/meter.

MILLIAMMETER RECORDER RD-59/U.

DRIVE MOTOR INPUT: 115 v, 60 cps, (obtained from Power Supply PP-449/URM-6 when operating from 115/220 v, 60 cps).

POWER SOURCE REQUIRED

AC OPERATION: 105-125 v/210-250 v, 50-1600 cps, 100 W.

DC OPERATION: 6 v DC, 4.1 amp to filaments. 225 v DC, 55 ma to plates. 67.5 v DC, 8 ma for bias.

OBSERVER COMPASS: 3 v DC from dry cells.

MANUFACTURER'S OR CONTRACTOR'S DATA

Stoddard Aircraft Radio Co, Hollywood, California.

Contract NObsr-39263, dated 27 June 1947.

TUBE AND/OR CRYSTAL COMPLEMENT

(2) OC3W	(6) 6AU6WA
(1) 6AT6	(1) 5726/6AL5W
(1) 6J6WA	(3) 6C4WA
(1) 5Y3WGT	(1) 5750/6BE6W
(1) 6X4WA	(1) 6E5

Total Tubes: (18)

No Crystals used.

REFERENCE DATA AND LITERATURE

NAVSHIPS 91196: Technical Manual for Radio Test Set AN/URM-6.

TYPE CLASSIFICATION
DESIGN COGNIZANCE BUSHIPS
PROCUREMENT COGNIZANCE
STOCK NO.
R.D.B. IDENT. NO.

Apr 11 1958

AN/URM-6

RADIO TEST SET

SHIPPING DATA				
NUMBER OF BOXES	CONTENTS AND IDENTIFICATION	VOLUME (Cu.Ft.)	OVERALL DIMENSIONS (inches)	WEIGHT PACKED (lbs.)
1	Radio Test Set AN/URM-6	26.2	25-1/2 x 37-1/2 x 47-1/2	297

EQUIPMENT SUPPLIED DATA			
QUANTITY PER EQUIPT	NAME AND NOMENCLATURE	OVERALL DIMENSIONS (inches)	WEIGHT (lbs.)
1	Case (Transit) CY-706/URM-6 Containing:	10-7/8 x 14-1/2 x 34-1/2	30
1	"RI-FI" Meter IM-36/URM-6	8 x 10-3/8 x 19-13/16	26
1	Power Supply PP-449/URM-6	7-31/32 x 9-29/32 x 19-3/4	24.75
1	Cable assembly (phone extension) CG-572/U	240 lg	
1	Cable assembly (recorder) CG-571/U	72 lg	
1	Cable assembly (battery) NT-62482	24 lg	
1	Cable assembly (oscilloscope) CG-573/U	36 lg	
1	Case (recorder) CY-708/URM-6 Containing:	11 x 14 x 18	15
	1 Milliammeter-Recorder RD-59/U		
	1 Power cable assembly NT-62480	72 lg	
	1 Shoulder strap		
1	Case (tripod) CY-709/URM-6 Containing:	9-1/4 dia x 41-1/2	
	2 Tripod MT-674/U		
1	Case (loop) CY-710/URM-6 Containing:	5 x 33-3/4 x 33-7/8	36
	1 Antenna AT-206/URM-6	30 dia	
1	Shoulder strap		
1	Impedance matching network (general purpose) CU-186/URM-6		
1	Cord CG-444/U	240 lg	
1	Cable assembly (remote meter) CG-571/U	240 lg	
1	Antenna, short rod AT-203/URM-6	51	
1	Antenna, long rod AT-204/URM-6	84	
1	Antenna small loop AT-205/URM-6	5 dia	
1	Adaptor, right angle UG-537/U		
1	RF cable assembly CG-577/URM-6		
1	Power Cable assembly NT-62480	72 lg	
1	Special purpose cable assembly NT-62481	120 lg	
1	Chart PT-107/URM-6		
1	Clipboard		
1	Headphones CW-49505		
2	Instruction Books NAVSHIPS 91196		
1	Case, (accessory) CY-707/URM-6 Containing:	6-3/4 x 21-1/8 x 27-3/4	
1	Observer-Compass Mark 1 Mod 0	4-3/4 x 4-7/8 x 10-7/8	
1	Ammeter ME-31/U		
1	Antenna (probe) AT-207/URM-6		
1	RF probe MX-951/URM-6		
1	Impedance matching network (50 0) CU-184/URM-6		
1	Impedance matching network (20 0) CU-185/URM-6		

1 March 1963

Cog Service: USN

FSN: F6625-049-8209

RADIO TEST SET AN/URM-6A

Functional Class: 5.6

USA

USN

USAF

TYPE CLASS:

Used by

MANUFACTURER'S NAME/CODE NUMBER: Eltron Inc., (85946).

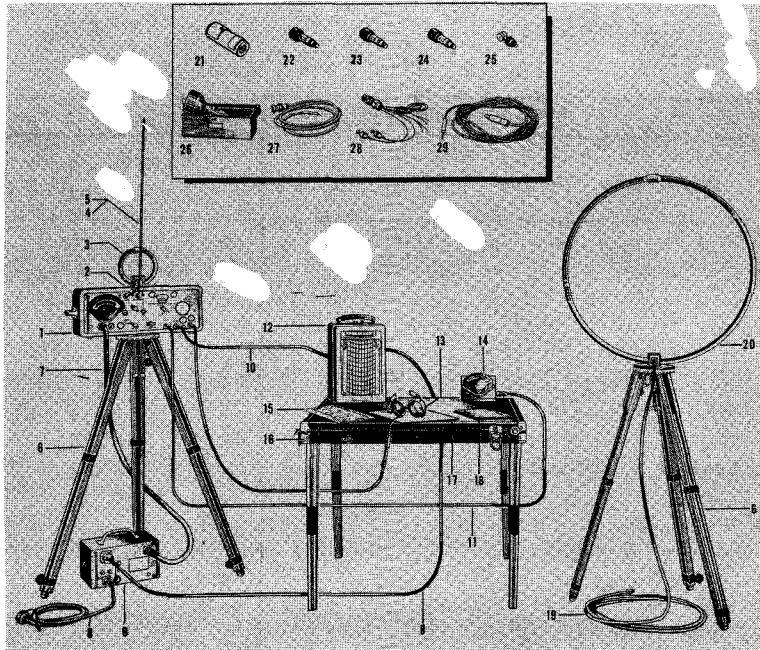

Radio Test Set AN/URM-6A

FUNCTIONAL DESCRIPTION:

AN/URM-6A is a radio interference and field intensity measuring equipment. It can be used for radio interference surveys to determine the source of radiated or conducted interference from equipment such as gasoline engine generators, motors or electronic equipment. Field intensity measurement surveys may be made with AN/URM-6A for adjusting directive antennas or for exploring radiation patterns, where the field intensity may vary over a wide range of values.

No field changes in effect at time of preparation (2 November 1960).

TECHNICAL CHARACTERISTICS:

FREQUENCY RANGE: 14 to 250 kc.

INTERMEDIATE FREQUENCY: 12.5 kc.

SELECTIVITY: Bandwidth at 6 db down varies between 100 cps at lower freq and 600 cps at

AN/URM-6A RADIO TEST SET

higher freq. Bandwidth at 60 db down is 2000 cps.
IMAGE REJECTION: Better than 50 db down from signal level.
INTERMEDIATE FREQUENCY REJECTION: 60 db or better.

SENSITIVITY

AS TWO TERMINAL VOLTMETER: 1 uv.

AS FIELD INTENSITY METER

WITH ANTENNA AT-204/URM-6: 1 uv per meter.

WITH ANTENNA AT-203/URM-6: 10 uv per meter.

AUDIO SENSITIVITY: 10 uv max output at audio freq consistent with bandpass characteristics.

SIGNAL TO NOISE RATIO: Unity or better throughout range of equipment.

AUDIO CHANNEL OUTPUT: 100 mw or better when operating into 600 ohm non-inductive load.

ACCURACY OF FIELD INTENSITY: 10% or better at signal levels above 10 uv.

DYNAMIC RANGE (OVERLOAD CHARACTERISTICS): 20 db at full scale.

OPERATING POWER REQUIREMENTS

AC: 105 to 125 or 210 to 250 v, single phase, 50 to 1600 cps, 100 W power consumption at 115 v 60 cps.

DC: 6 v, 67.5 v and 225 v battery operation.

RELATION TO OTHER EQUIPMENT:

The AN/URM-6A is similar to and interchangeable with AN/URM-6 except for minor differences in components and maintenance parts.

EQUIPMENT REQUIRED BUT NOT SUPPLIED:

(2) Batteries BA30; (1) NT 6V-SBMD-175AH Battery; (5) BA26, Batteries; (1) 675.5 v battery.

MAJOR COMPONENTS

QTY	ITEM	STOCK NUMBERS	DIMENSIONS (INCHES)	WEIGHT (LBS)
1	Case CY-706A/URM-6 consists of:		10-7/8 x 14-1/2 x 34-1/2	30
1	Radio Interference Field Intensity Meter IM-36/URM-6		8 x 10-3/8 x 19-13/16	26
1	Power Supply PP-449/URM-6		7-31/32 x 9-29/32 x 19-3/4	24.75
1	Antenna AT-203/URM-6			
1	Antenna AT-204/URM-6			
1	Antenna AT-205/URM-6			
1	Adapter UG-537/U			
1	RF Cable Assy CG-577/URM-6			
1	Cable Assy Power CADV-62480		72 lg	
2	Cable Special Purpose Assy CADV-62481		120 lg	
1	Chart PT-107/URM-6			
1	Headphone CW-49509			

4.5 AN/URM-6A: 2

RADIO TEST SET AN/URM-6A

QTY	ITEM	STOCK NUMBERS	DIMENSIONS (INCHES)	WEIGHT (LBS)
2	Technical Manual NAVSHIPS 91196			
1	Case CY-707A consists of:		6-3/4 x 21-1/8 x 27-3/4	24
1	Observer-Compass Mark 1 Mod 0		4-3/4 x 4-7/8 x 10-7/8	4-3/4
1	Ammeter ME-31/U		3-7/8 x 3-7/8 x 5-25/32	
1	Antenna AT-207A/URM-6		3/4 dia x 2 lg	
1	RF Probe MX-951/URM-6			
1	Impedance Matching Network CU-184/URM-6		15/16 dia x 2-5/8 lg	
1	Impedance Matching Network CU-185/URM-6		15/16 dia x 2-5/8 lg	
1	Impedance Matching Network CU-186/URM-6		15/16 dia x 2-5/8 lg	
1	Cord CG-444/U (20' 0")		240 lg	
1	Special Purpose Cable Assy CG-571/U (20' 0")		240 lg	
1	Special Purpose Cable Assy CG-572/U (20' 0")		240 lg	
1	Special Purpose Cable Assy CG-571/U (6' 0")		72 lg	
1	Special Purpose Cable Assy CADV-62482 (2' 0")		24 lg	
1	Special Purpose Cable Assy CG-573/U (3' 0")		36 lg	
1	Case, Recorder CY-708/URM-6 consists of:		11 x 14 x 18	15
1	Milliammeter-Recorder RD-59/U		8-9/16 x 8-3/4 x 13-1/4	
1	Power Cable Assy CADV-62480 (6' 0")		72 lg	
1	Shoulder Strap			
1	Case, Tripod CY-709/URM-6 consists of:		9-1/2 dia x 41-1/2 lg	5
2	Tripod MT-674/U			
1	Case Loop CY-710A/URM-6 consists of:		5 x 33-3/4 x 33-7/8	36
1	Antenna AT-206/URM-6		30 dia	
1	Shoulder Strap			

REFERENCE DATA AND LITERATURE:

AN/URM-6A RADIO TEST SET

TUBE, CRYSTAL AND/OR SEMI-CONDUCTOR DATA:

TUBES: (2) 0C3/VR-105 (1) 5Y3GT (1) 6AL5 (1) 6AT6 (6) 6AU6 (1) 6BE6 (3) 6C4
(1) 6E5 (1) 6J6 (1) 6X4

CRYSTALS: None used.

SEMI-CONDUCTORS: None used.

SHIPPING DATA

PKGS	VOLUME (CU FT)	WEIGHT (LBS)
1	26.2	297

PROCUREMENT DATA

PROCURING SERVICE: USN
SPEC &/OR DWG: CS-1189

DESIGN COG: USN, BuShips

CONTRACTOR	LOCATION	CONTRACT OR ORDER NO.	APPROX. UNIT COST
Eltron Inc.	Jackson, Mich.	N0bsr-43433	

RADIO TEST SET

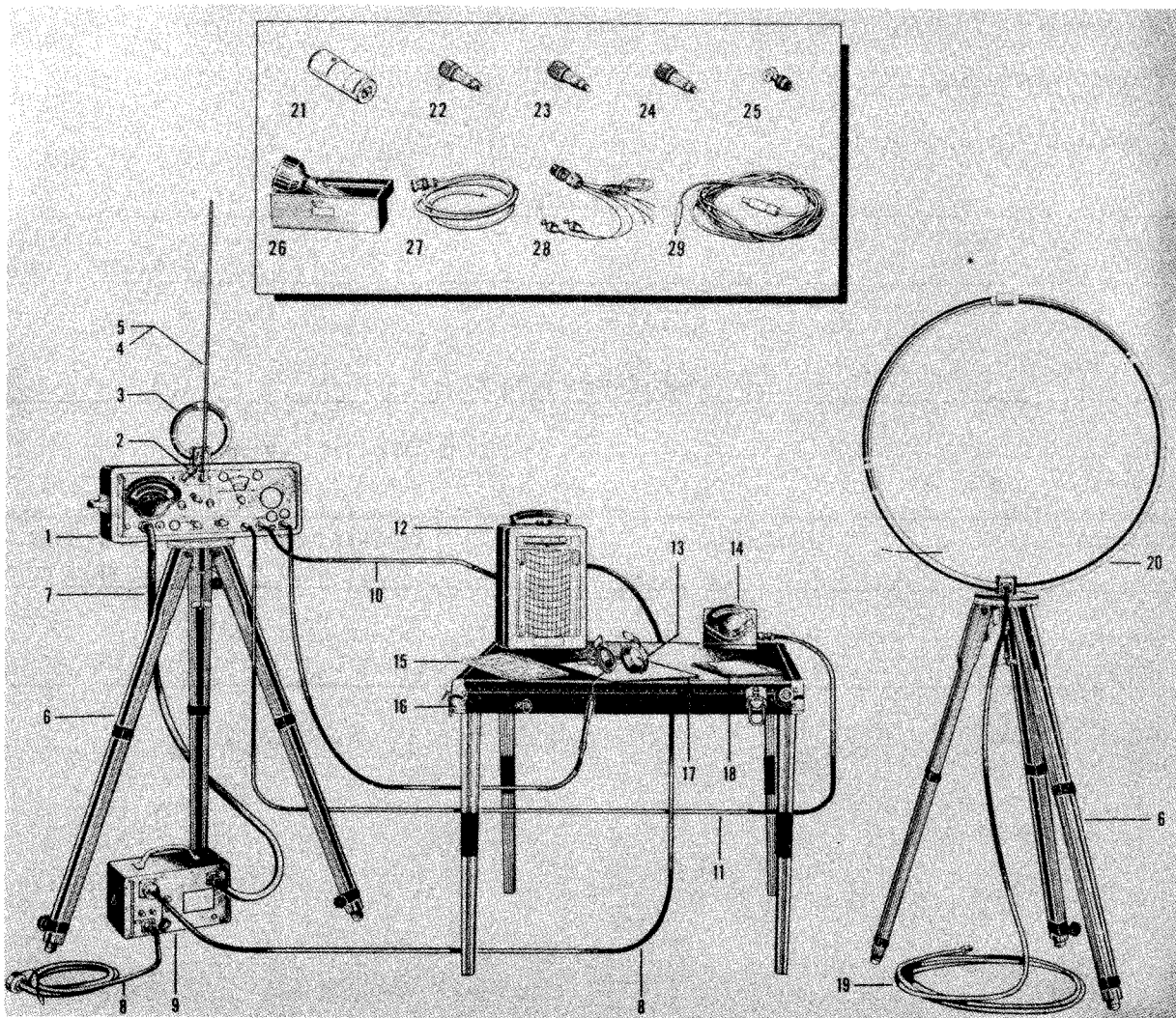

Radio Test Set AN/URM-6B

FUNCTIONAL DESCRIPTION

Radio Test set AN/URM-6B is a portable radio interference and field intensity meter designed for field use, operating over the 14 to 250 kc portion of the radio spectrum.

It is used for making radio interference surveys to determine the source of radiated or conducted interference from equipment, such as gasoline engine generators, motors or electronic equipment.

Field intensity measurement surveys may also be made with this equipment for exploring radiation patterns and adjusting directive antennas, where field intensity may vary

over a wide range of values.

No field changes in effect at time of preparation (11 April 1958).

RELATION TO OTHER EQUIPMENT

The AN/URM-6B is the same as Radio Test Set AN/URM-6 except for minor differences in component parts used in Radio Interference-Field Intensity Meter unit of each test set. All units of each test set are directly interchangeable.

April 1958

Test-Field Intensity Measuring

AN/URM-6B**RADIO TEST SET****ELECTRICAL AND MECHANICAL CHARACTERISTICS**

FREQUENCY RANGE: 14 to 250 kc.
 INTERMEDIATE FREQUENCY: 12.5 kc.
 SELECTIVITY: Bandwidth at 6 db down varies between approx 100 cps at lower frequencies and 600 cps at higher frequencies. Bandwidth at 60 db down is approx 2000 cps.

IMAGE REJECTION: Better than 50 db down from signal level.

INTERMEDIATE FREQUENCY REJECTION: 60 db or better.

SENSITIVITY

AS A TWO TERMINAL VOLTMETER: 1 uv.

AS A FIELD INTENSITY METER: 1 uv per meter with Antenna AT-204/URM-6, 10 uv per meter with antenna AT-203/URM-6.

AUDIO SENSITIVITY: Max output obtained with meter indication of 10 microvolts at audio frequencies consistent with bandpass characteristics.

SIGNAL TO NOISE RATIO: Unity or better.

AUDIO CHANNEL OUTPUT: 100 mw or better when operating into a 600 ohm noninductive load.

ACCURACY OF FIELD INTENSITY MEASUREMENTS: 10% or better at signal levels above 10 uv. Variable at signal levels below 10 uv, and dependent upon the ambient level of interference background, the frequency at which the equipment is tuned and the characteristics of that quantity being measured.

DYNAMIC RANGE: 20 db at full scale.

AC POWER SOURCE REQUIRED: 105 to 125 v or 210 to 250 v, single ph, 50 to 1600 cps (except for milliammeter-recorder RD-59/U, which utilize a 60 cps synchronous motor) 100 W at 115 v, 60 cps.

BATTERIES USED WHEN AC IS NOT AVAILABLE

FILLAMENT: 6 v, 1 type 6V-SBMD-175AH.

PLATE: 225 v, 5 type BA-26.

BIAS: 67.5 v, 3 sections of 2 type BA-26 or 1 BA-26 and 1 BA-2.

BATTERIES USED AT ALL TIMES

OBSERVER COMPASS: 3 v, 1 Type BA-30.

MANUFACTURER'S OR CONTRACTOR'S DATA

Stoddard Aircraft Radio Co., Inc., Hollywood, California.

Contract NObsr-52488, dated 7 June 1951.

Contract NObsr-57196, dated 31 January 1952.

Contract NObsr-64090, dated 15 December 1953.

Approximate Cost: \$4150.00 with equipment spares.

TUBE AND/OR CRYSTAL COMPLEMENT

(2) OC3W (1) 5Y3WGTB (1) 6AT6
 (6) 6AU6WA (3) 6C4WA (1) 6E5
 (1) 6J6WA (1) 6X4WA (1) 5726/6AL-5W
 (1) 5750/6BE6W

Total Tubes: (18)

No Crystals used.

REFERENCE DATA AND LITERATURE

NAVSHIPS 91683: Technical Manual for Radio Test Set AN/URM-6B.

TYPE CLASSIFICATION	
DESIGN COGNIZANCE	BUSHIPS
PROCUREMENT COGNIZANCE	MIL-T-16202 and
STOCK NO.	MIL-T-16202A
R.D.B. IDENT. NO.	

SHIPPING DATA

NUMBER OF BOXES	CONTENTS AND IDENTIFICATION	VOLUME (Cu.Ft.)	OVERALL DIMENSIONS (inches)	WEIGHT PACKED (lbs.)
1	Radio Test Set AN/URM-6B	26.2	25-1/2 X 37-1/2 X 47-1/2	297

UNCLASSIFIED

April 1958

Test-Field Intensity Measuring

RADIO TEST SET

AN/URM-6B

EQUIPMENT SUPPLIED DATA

QUANTITY PER EQUIPT	NAME AND NOMENCLATURE	OVERALL DIMENSIONS (inches)	WEIGHT (lbs.)
1	Case (Transit) CY-706/URM-6 containing:	9-1/2 X 12-3/4 X 31-1/4	30
1	Radio Interference-Field Intensity Meter IM-36A/URM-6	8 X 10-3/8 X 19-13/16	26
1	Power Supply PP-449/URM-6	7-31/32 X 9-29/32 X 29-3/4	24.75
1	Antenna AT-203/URM-6	53 lg	
1	Antenna AT-204/URM-6	86 lg	
1	Antenna AT-205/URM-6	5-1/4 dia	
1	Adapter UG-537/U		
1	RF Cable Assembly CG-577/URM-6		
1	Power Cable Assembly NT-62480	72 lg	
1	Special Purpose Cable Assembly NT-62481	120 lg	
1	Chart PP-107/URM-6		
1	Clipboard		
1	Set of Headphones NT-49507A		
2	Technical Manuals NAVSHIPS 91683		
1	Case (Accessory) CY-707/URM-6 containing:	6 X 20 X 30	24
1	Observer-Compass, with case MK 1 MOD 0	4-3/4 X 4-7/8 X 10-7/8	4.75
1	Ammeter ME-31/U		
1	Antenna AT-207/URM-6		
1	RF Probe MX-951/URM-6		
1	Impedance Matching Network CU-184/URM-6		
1	Impedance Matching Network CU-185/URM-6		
1	Impedance Matching Network CU-186/URM-6		
1	Cord CG-444/U	240 lg	
1	Special Purpose Cable Assembly CG-571/U	240 lg	
1	Special Purpose Cable Assembly CG-572/U	240 lg	
1	Special Purpose Cable Assembly CG-571/U	72 lg	
1	Special Purpose Cable Assembly NT-62482	24 lg	
1	Special Purpose Cable Assembly CG-573/U	36 lg	
1	Case (Recorder) CY-708/URM-6 containing:	10 X 13-3/4 X 16-3/4	15
1	Milliammeter-Recorder with inking kit RD-59/U	8-9/16 X 8-3/4 X 13-1/4	
1	Power Cable Assembly NT-62480	72 lg	
1	Shoulder Strap		
1	Case (Tripod) CY-709/URM-6 containing:	9 dia X 42	5
2	Tripod MT-674/U		
1	Case (Loop) CY-710/URM-6 containing:	5 X 34 X 34	36
1	Antenna AT-206/URM-6	30 dia	
1	Shoulder Strap		

UNCLASSIFIED

4.5 AN/URM-6B: 3

25 May 1962

Cog Service: USN FSN:

RADIO TEST SET AN/URM-6C

Functional Class: 5.6

USA

USN

USAF

TYPE CLASS:

MANUFACTURER'S NAME/CODE NUMBER: Espey Mfg Co. Inc., (20950).

(No Illustration Available)

FUNCTIONAL DESCRIPTION:

Radio Test Set AN/URM-6C is used for radio interference surveys to determine the source of radiated or conducted interference from equipment such as gasoline engine generators, motors or electronic equipment. Field intensity measurement surveys may be made with Radio Test Set AN/URM-6C for adjusting directive antennas or for exploring radiation patterns, where the field intensity may vary over a wide range of values. This equipment can also be used as a microvoltmeter for any rf measurement within its frequency range. The equipment is suitable for operation aboard naval vessels, at shore stations, in the field, in aircraft, and in military vehicles.

No field changes in effect at time of preparation (1 February 1962).

TECHNICAL CHARACTERISTICS:

FREQUENCY RANGE: 14 to 250 kc.

INTERMEDIATE FREQUENCY: 12.5 kc.

SELECTIVITY: 6 db down at 100 cyc at lower freq; 6 db down at 600 cyc at higher freq; 60 db down at 2000 cyc.

IMAGE REJECTION: Better than 50 db down from signal level.

I-F REJECTION: 60 db or better.

SENSITIVITY

AS TWO TERMINAL VOLTMETER: 1 uv.

AS FIELD INTENSITY METER

WITH ANTENNA AT-515/URM-6C: 1 uv per meter.

WITH ANTENNA AT-514/URM-6C: 10 uv per meter.

AUDIO SENSITIVITY: 10 uv at audio freq.

SIGNAL-TO-NOISE RATIO: Unity or better throughout range of equipment.

AUDIO CHANNEL OUTPUT: 100 mw or better when operating into 600 ohm load.

ACCURACY OF FIELD INTENSITY MEASUREMENTS: Porm 10% or better at signal levels above 10 uv.

DYNAMIC RANGE: 10 db at full scale.

POWER REQUIREMENTS

AC: 115 W, 105 to 125 v or 210 to 250 v, 50 to 1000 cyc, single ph; 115 W, 115 v, 60 cyc (milliammeter-recorder).

DC: 3 v (observer compass); 6 v, 4.1 amp (fil); 67.5, 8 ma (bias); 225 v, 55 ma (plate).

RELATION TO OTHER EQUIPMENT: None.

EQUIPMENT REQUIRED BUT NOT SUPPLIED:

Batteries: (1) BA-2, (5) BA-26, (2) BA-30, (1) NT-6V-SBMD-175AH.

AN/URM-6C RADIO TEST SET

MAJOR COMPONENTS

QTY	ITEM	STOCK NUMBERS	DIMENSIONS (INCHES)	WEIGHT (LBS)
1	Case, Standardized Components, Electrical CY-1629/URM-6C consists of:		10-7/8 x 14-1/2 x 34-1/2	30
1	Radio Interference-Field Intensity Meter IM-102/URM-6C		8 x 10-3/8 x 19-13/16	26
1	Power Supply PP-1174/URM-6C		7-31/32 x 9-29/32 x 19-3/4	24.75
1	Antenna AT-514/URM-6C		51 lg	
1	Antenna AT-515/URM-6C		84 lg	
1	Antenna AT-516/URM-6C		5 dia	
1	Adapter Connector UG-537/U			
1	RF Cable Assy CG-577/URM-6			
1	Cable Assy, Power 62480		72 lg	
1	Cable Assy, Special Purpose 62481		120 lg	
1	Chart PT-107/URM-6			
1	Clipboard			
2	Technical Manual			
1	Headphones 49509			
1	Case, Accessories CY-1630/URM-6C consists of:		6-3/4 x 21-1/8 x 27-3/4	24
1	Observer-Compass Mark 1 Mod 0		4-3/4 x 4-7/8 x 10-7/8	4.75
1	Antenna AT-207/URM-6			
1	RF Probe MX-951/URM-6			
1	Impedance Matching Network CU-184/URM-6			
1	Impedance Matching Network CU-185/URM-6			
1	Impedance Matching Network CU-186/URM-6			
1	Cord CG-444/U		140 lg	
1	Cable Assy, Special Purpose CG-571/U		140 lg	
1	Cable Assy, Special Purpose CG-572/U		140 lg	
1	Cable Assy, Special Purpose CG-571/U		72 lg	
1	Cable Assy, Special Purpose 62482		24 lg	
1	Cable Assy, Special Purpose CG-573/U		36 lg	
1	Case, Standardized Components, Electrical CY-1631/URM-6C consists of:		11 x 14 x 18	15

RADIO TEST SET AN/URM-6C

QTY	ITEM	STOCK NUMBERS	DIMENSIONS (INCHES)	WEIGHT (LBS)
1	Milliammeter-Recorder RD-59/U		8-9/16 x 8-3/4 x 13-1/4	
1	Cable Assy, Power 62480		72 lg	
1	Shoulder Strap			
1	Case, Antenna Tripod CY-1632/U		9-1/4 dia x 41-1/2	5
	consists of:			
2	Tripod MT-1455/U			
1	Case, Antenna CY-1633/URM-6C		5 x 33-3/4 x 33-7/8	36
	consists of:			
1	Antenna AT-517/URM-6C		30 dia	
1	Shoulder Strap			

REFERENCE DATA AND LITERATURE:

NAVSHIPS 92271: Technical Manual for Radio Test Set AN/URM-6C.

TUBE, CRYSTAL AND/OR SEMI-CONDUCTOR DATA:

TUBES: (2) 0C3/VR105 (1) 5Y3GT (1) 6AL5 (1) 6AT6 (6) 6AU6 (1) 6BE6 (3) 6C4
 (1) 6E5 (1) 6J6 (1) 6X4

CRYSTALS: None used.

SEMI-CONDUCTORS: None used.

SHIPPING DATA

PKGS	VOLUME (CU FT)	WEIGHT (LBS)
1	26.2	297

PROCUREMENT DATA

PROCURING SERVICE: USN
 SPEC &/OR DWG: SHIPS-T-172

DESIGN COG: USN, BuShips

CONTRACTOR	LOCATION	CONTRACT OR ORDER NO.	APPROX. UNIT COST
Espey Mfg Co., Inc.	New York, N. Y.	N0bsr-49240 26 June 1950	

FIELD STRENGTH METER

AN/URM-91

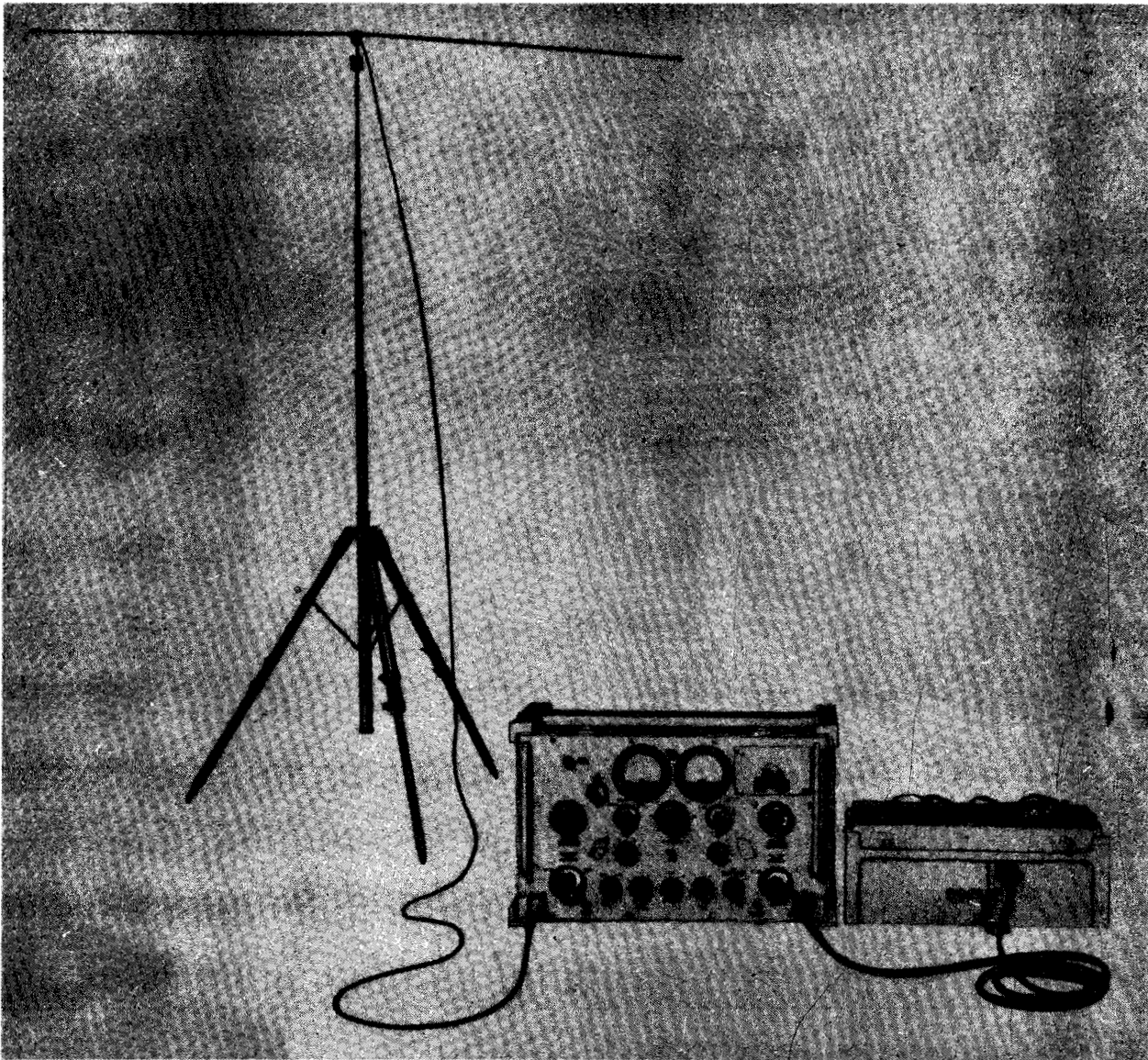

Field Strength Meter AN/URM-91

FUNCTIONAL DESCRIPTION

The AN/URM-91 is a transportable test set designed to measure the radiation field intensities of amplitude modulated (AM), frequency modulated (FM) or continuous-wave (CW) transmitting stations operating in the frequency range of 18 to 125 megacycles. It provides either linear or logarithmic output for single field-intensity readings or for use with a recorder to make continuous

records of signal intensity variation while the equipment is unattended.

This meter will determine reception characteristics such as signal intensity, fading and atmospheric, at a site for any period of time, will measure transmitter coverage, will measure changes in transmitter or transmitter-antenna characteristics and measure spurious radiation.

No field changes in effect at time of preparation (3 April 1957).

October 1957

Test-Field Intensity Measuring

AN/URM-91**FIELD STRENGTH METER****RELATION TO OTHER EQUIPMENT**

Equipment Required but not Supplied: (4) Batteries BB-242/U, (2) batteries BA-34, and a recording instrument if a continuous recording of field strength indications is intended.

ELECTRICAL AND MECHANICAL CHARACTERISTICS

FIELD STRENGTH METER IM-117/URM-91.

RECEIVER TYPE: Superheterodyne.

FREQUENCY BANDS: 18 to 35 mc, 33 to 66 mc, 62 to 125 mc.

TYPES OF SIGNALS: AM, FM and CW.

INTERMEDIATE FREQUENCY: 10.7 mc.

METHOD OF CALIBRATION: Internal calibration oscillator.

OUTPUTS: Direct reading meter calibrated in microvolts and decibels, recorder jack and audio jack.

ACCURACY OF FREQUENCY CALIBRATION: $\pm 2\%$.ACCURACY OF FIELD STRENGTH MEASUREMENTS: ± 2 db.

FIELD STRENGTH RANGE

LOW FREQUENCY END: 5 to 50,000 uv/m.

HIGH FREQUENCY END: 10 to 50,000 uv/m.

BIAS SUPPLY: 2 BA-34 batteries.

POWER SOURCE REQUIRED: 185 v DC at 65 ma and 6 v DC at 2 amp.

POWER SUPPLY PP-1642/URM-91

POWER OUTPUTS: 185 v DC and 6 v DC.

OPERATING TIME ON FULL CHARGE: 6 hr.

POWER SOURCE REQUIRED: 110 v, 60 cps for battery charger.

ANTENNA AS-802/URM-91

TYPE: Dipole, adjustable for frequency range 18 mc to 125 mc.

ORIENTATION: Vertical or horizontal.

DIPOLE ELEMENTS: 12 fixed sections and 2 telescoping sections.

MOUNTING: Tripod with telescoping mast sections for height adjustments.

TUBE AND/OR CRYSTAL COMPLEMENT

(1) 6BF6

(1) OA2

(4) 6BJ6

(1) 6BQ7A

(2) 6C4

(1) 12AT7

Total Tubes: (10)

(2) 1N34A

Total Crystals: (2)

REFERENCE DATA AND LITERATURE

TM11-5041, TO33A1-4-33-1, Technical Manual for Field Strength Meter AN/URM-91.

TYPE CLASSIFICATION
DESIGN COGNIZANCE TASSA
PROCUREMENT COGNIZANCE
STOCK NO.
R.D.B. IDENT. NO.

SHIPPING DATA

NUMBER OF BOXES	CONTENTS AND IDENTIFICATION	VOLUME (Cu.Ft.)	OVERALL DIMENSIONS (inches)	WEIGHT PACKED (lbs.)
1	Field Strength Meter IM-117/URM-91	3.12	17 X 17-1/2 X 24	61
1	Power Supply PP-1642/URM-91	1.81	12 X 13 X 20	63
1	Antenna AS-802/URM-91	5.3	13-1/2 X 15-1/2 X 44	70

EQUIPMENT SUPPLIED DATA

QUANTITY PER EQUIP	NAME AND NOMENCLATURE	OVERALL DIMENSIONS (inches)	WEIGHT (lbs.)
1	Field Strength Meter IM-117/URM-91	13 X 13-1/2 X 19-7/8	41
1	Power Supply PP-1642/URM-91	8-1/4 X 9 X 16	43
1	Cord CD-307A (8'0")		1.

UNCLASSIFIED

January 1961

Test-Field Intensity Measuring

TEST SET, ANTENNA

AN/USM-107(XN-1)

FUNCTIONAL DESCRIPTION

Antenna Test Set AN/USM-107(XN-1) is a portable set for testing antennas. It consists basically of a receiver-amplifier with a recorder output terminal, a transmitter for the generation of frequencies between 1000 to 10500 mc and a frequency meter for the calibration of the selected transmission frequencies. Capacity is provided for making the power ratio measurements required in antenna radiation pattern and gain measurements.

No field changes in effect at time of preparation (25 April 1960).

ELECTRICAL AND MECHANICAL CHARACTERISTICS

TRANSMITTER, RADIO

FREQUENCY RANGE: 1000 to 10500 mc.

FREQUENCY DIAL ACCURACY: Form 2%.

TYPES OF OUTPUT: CW and 1000 cps square wave.

IMPEDANCE: 50 ohms (output).

RECEIVER, RADIO

DETECTOR: Crystal.

DETECTOR RESPONSE: Square Law.

FREQUENCY RANGE: 1000 to 10500 mc.

POWER REQUIREMENTS: 115 v \pm 10 v, 60 cyc, single ph.

MANUFACTURER'S OR CONTRACTOR'S DATA

Polytechnic Research and Development Co Inc., Brooklyn, New York.

Contract NObsr-63474.

TUBE AND/OR CRYSTAL COMPLEMENT

No Electron Tube or Crystal data available.

REFERENCE DATA AND LITERATURE

Nomenclature Card for TEST SET ANTENNA AN/USM-107(XN-1).

TYPE CLASSIFICATION (NAVY)
DESIGN COGNIZANCE USN, BUSHIPS
PROCUREMENT COGNIZANCE SPEC: SHIPS-S-1124
STOCK NO.
R.D.B. IDENT. NO.

EQUIPMENT SUPPLIED DATA

QUANTITY PER EQUIPT	NAME AND NOMENCLATURE	OVERALL DIMENSIONS (inches)	WEIGHT (lbs.)
1	Test Set, Antenna AN/USM-107(XN-1) Includes:		
1	Transmitter, Radio Unit 1		
1	Receiver, Radio Unit 2		
1	Frequency Meter Unit 3		
1	Case, Accessories Unit 4		

UNCLASSIFIED

4.5 AN/USM-107(XN-1): 1

UNCLASSIFIED

February 1960

Test-Field Intensity Measuring

SONAR TEST SET

AN/WQM-1

FUNCTIONAL DESCRIPTION

Contract NObsr-64277, dated 28 June 1954.

Sonar Test Set AN/WQM-1 develops a Figure of Merit, or relationship between noise background and signal strength, and can be employed thereby to show the greatest background noise through which a satisfactory signal is received.

No field changes in effect at time of preparation (7 July 1959).

TUBE AND/OR CRYSTAL COMPLEMENT

- (1) OB2WA
- (1) 12AV7
- (1) 5Y3WGTB
- (1) 6005/6AQ5W
- (3) 12AT7WA
- (1) 12AX7
- (1) 5726/6AL5W

Total Tubes: (9)

No Crystals used.

ELECTRICAL AND MECHANICAL CHARACTERISTICS

POWER REQUIREMENTS: 117 v, 60 cy, single ph.

SIGNAL GENERATOR

FREQUENCY RANGE: 20 to 39 kc.

OUTPUT: 0 to 60 db.

MULTIMETER

DECIBLE METER RANGE: 0 to 20 db.

METER RANGE: 0.001 to 100 v.

REFERENCE DATA AND LITERATURE

Nomenclature Card for TEST SET, SONAR AN/WQM-1.

TYPE CLASSIFICATION

DESIGN COGNIZANCE NAVY, BUSHIPS

PROCUREMENT COGNIZANCE SPEC: SHIPS-F-1386

STOCK NO.

R.D.B. IDENT. NO.

MANUFACTURER'S OR CONTRACTOR'S DATA

Electronic Engineering and Service Co.,
Inc., Fall Church Va.

EQUIPMENT SUPPLIED DATA

QUANTITY PER EQUIPT	NAME AND NOMENCLATURE	OVERALL DIMENSIONS (inches)	WEIGHT (lbs.)
1	Signal Generator SG-133/WQM-1		
1	Cover, Signal Generator CW-401/WQM-1		
1	Recorder, Polar Electromechanical RO-30/WQM-1		
1	Cover, Recorder CW-402/WQM-1		
1	Electronic Multimeter ME-6/U	4-1/2 X 5-3/4 X 11	9.5
1	Oscilloscope OS-8/U	5-1/4 X 7-3/8 X 11-15/16	
1	Transducer Assembly NT-51112-A		
1	Handwheel Drive PD-50/WQM-1		
1	Hoist, Wire Rope E-24/WQM-1		
3	Case, Carrying, Electrical Equipment CY-1884/WQM-1	12 X 14 X 18	
3	Cover, Case CW-403/WQM-1		
1	Cable Assy, Special Purpose, Electrical CX-3404/WQM-1		
1	Cable Assy, Special Purpose, Electrical CX-3405/WQM-1		
1	Cable Assy, Special Purpose, Electrical CX-3406/WQM-1		
1	Cable Assy, Special Purpose, Electrical CX-3407/WQM-1		
1	Cable Assy, Special Purpose, Electrical CX-3408/WQM-1		

UNCLASSIFIED

4.5 AN/WQM-1: 1

AN/WQM-1

SONAR TEST SET

EQUIPMENT SUPPLIED DATA

QUANTITY PER EQUIPT	NAME AND NOMENCLATURE	OVERALL DIMENSIONS (inches)	WEIGHT (lbs.)
1	Cable Assy, Special Purpose, Electrical CX-3409/ WQM-1		
1	Cable Assy, Special Purpose, Electrical CX-3410/ WQM-1		
1	Cable Assy, Special Purpose, Electrical CX-3411/ WQM-1		
1	Cable Assy, Special Purpose, Electrical CX-3412/ WQM-1		
1	Cable Assy, Special Purpose, Electrical CX-3413/ WQM-1		

19 February 1963

OCTAVE BAND NOISE ANALYZER CAG-1550-A

Cog Service:

FSN:

Functional Class: 5

USA

USN

USAF

TYPE CLASS:

MANUFACTURER'S NAME/CODE NUMBER: General Radio Co., (24655).

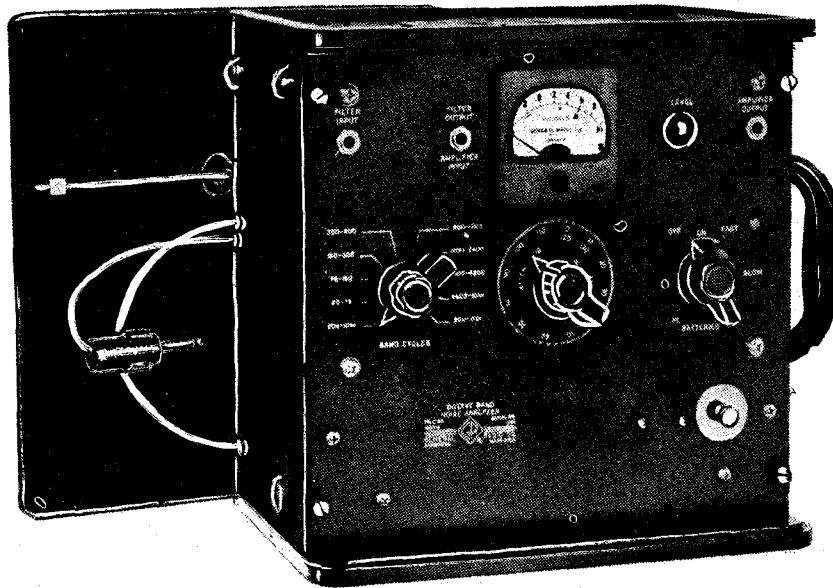

Octave Band Noise Analyzer CAG-1550-A

FUNCTIONAL DESCRIPTION:

The CAG-1550-A is portable, battery-powered and operates from the output of a sound-level meter, or when the level is sufficiently high, directly from a microphone. It contains eight (8) band pass filters, any one of which can be selected by a switch; an attenuator; and an amplifier, which drives both an indicating meter and a monitoring output.

No field changes in effect at time of preparation (7 February 1963).

TECHNICAL CHARACTERISTICS:

USES

ONE: Measurement of noise on aircraft, vehicles, and machinery.

TWO: The analysis of environmental noise, as in offices and factories, where speech-interference level is important.

THREE: Studies of environmental noise as related to hearing damage.

CAG-1550-A OCTAVE BAND NOISE ANALYZER

FOUR: Production testing and noise-level acceptance tests.
INPUT LEVEL: Between 1 and 10 volts for normal range.
INPUT IMPEDANCE: 20000 ohms.
LEVEL INDICATION: Level is sum of meter and attenuator readings.
ATTENUATION: At least 30 db.
NUMBER OF CHANNELS: 8 channels.
OPERATING FREQUENCY RANGE: 20 to 10000 cps.
CHANNEL FREQUENCY (LOW PASS)
CHANNEL ONE: 20 to 75 cps.
CHANNEL TWO: 75 to 150 cps.
CHANNEL THREE: 150 to 300 cps.
CHANNEL FOUR: 300 to 600 cps.
CHANNEL FREQUENCY (HIGH PASS)
CHANNEL FIVE: 600 to 1200 cps.
CHANNEL SIX: 1200 to 2400 cps.
CHANNEL SEVEN: 2400 to 4800 cps.
CHANNEL EIGHT: 4800 to 10000 cps.
POWER SUPPLY: Battery-Burgess Type 6TA60, 1.5 v dc, 0.05 amp; Type 1261-A, 105 to 125 v ac, 40 to 400 cps, 10 W.

RELATION TO OTHER EQUIPMENT: None.

EQUIPMENT REQUIRED BUT NOT SUPPLIED: None.

MAJOR COMPONENTS

QTY	ITEM	STOCK NUMBERS	DIMENSIONS (INCHES)	WEIGHT (LBS)
1	Octave Band Noise Analyzer Type CAG-1550-A		9 x 11-5/8 x 12-9/16	27
1	Microphone Adapter Plug 1550-P1			
*1	AC Power Supply 1261A		2-1/4 x 5 x 10	7-3/4

*Optional.

REFERENCE DATA AND LITERATURE:

TUBE, CRYSTAL AND/OR SEMI-CONDUCTOR DATA:

TUBES: (3) 1U4 (1) 1T4

CRYSTALS: None used.

SEMI-CONDUCTORS: None used.

SHIPPING DATA

PKS	VOLUME (CU FT)	WEIGHT (LBS)
-----	----------------	--------------

4.5 CAG-1550-A: 2

PROCUREMENT DATA

PROCURING SERVICE:
SPEC &/OR DWG:

DESIGN COG: Commercial

CONTRACTOR	LOCATION	CONTRACT OR ORDER NO.	APPROX. UNIT COST
General Radio Co., Type no. 1550-A	Cambridge, Mass.		\$535.00

6 June 1962
Cog Service:

FSN: 6625-321-4332

SOUND-LEVEL METER CAG-1551-A
Functional Class:

USA

USN

USAF

TYPE CLASS:

MANUFACTURER'S NAME/CODE NUMBER: General Radio Company.

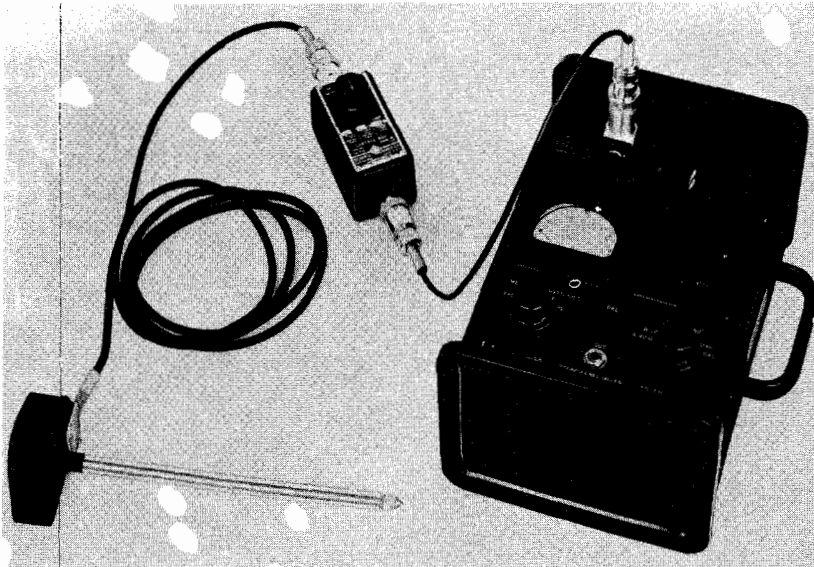

Sound-Level Meter CAG-1551-A

FUNCTIONAL DESCRIPTION:

Sound-Level Meter CAG-1551-A is an accurate, portable instrument for reading, in terms of a standard reference level, the sound level at its microphone. It consists of a non-directional microphone, an amplifier, a calibrated attenuator, an indicating meter, and weighting networks to modify the amplifier's response. It is battery operated as furnished.

The Type 759-P35 Vibration Pickup is an inertia operated crystal device which generates a voltage proportional to the acceleration of the vibrating body.

By means of integrating networks in the Type 759-P36 Control Box, voltage proportional to velocity and displacement can also be delivered to the sound-level meter. The desired response is selected by means of a three point switch on the control box.

No field changes in effect at time of preparation (11 July 1961).

CAG-1551-A SOUND-LEVEL METER

TECHNICAL CHARACTERISTICS:

- POWER SUPPLY:** Two 1-1/2-volt size D flashlight cells (Eveready 950 or equivalent); one Eveready 467B Battery or equivalent. Batteries are supplied. The General Radio Type 1262-A Power Supply is available if ac operation is desired.
- SOUND-LEVEL RANGE:** From 24 db to 140 db above the standard sound pressure reference level of 0.0002 microbar (a pressure of 0.0002 dyne per square centimeter) at 1000 cycles.
- FREQUENCY CHARACTERISTICS:** Any one of 4 response characteristics can be selected by means of a panel switch. Three of these, with the microphone supplied, are respectively the A-(40-db) and B-(70-db) equal loudness contours and the C-(flat) response specified, between 25 and 8000 cycles, in the current standard by the American Standards Association. The C-or Flat response is used when measuring extremely high sound-levels. When measuring sound pressure levels, or when using the instrument with the Type 760-B Sound Analyzer, the Type 736-A Wave Analyzer, or the Type 1550-A Octave-Band Noise Analyzer. The fourth frequency response characteristics provides an amplifier which has essentially flat response from 20 cyc to 20 kc, so that full use can be made of extremely wide range microphones, such as the Type 1551-P1 Condenser Microphone System.
- MICROPHONE:** The microphone is of the Rochell-Salt, crystal diaphragm type with an essentially non-directional response characteristics.
- SOUND-LEVEL INDICATOR:** The sound-level is indicated by the sum of the readings of the meter and an attenuator. The meter has a range of 16 db, and the attenuator has a range of 100 db in 10 db steps.
- OUTPUT TERMINALS:** A jack is provided, at which an output of 1 v across 20,000 ohms can be obtained when the panel meter reads full scale. This output is suitable for use with the Type 760-B Sound Analyzer, the Type 736-A Wave Analyzer, the Type 1550-A Octave-Band Noise Analyzer, a graphic level recorder, or a magnetic tape recorder. A Slow-Fast switch makes available two meter speeds with the control switch. In the Fast position, the ballistic characteristics of the meter simulate those of the human ear and agree with the current standards of the A.S.A. In the Slow position, the meter is heavily damped for observing the average level of rapidly fluctuating sounds.
- CALIBRATION:** A means is provided for standardizing the sensitivity of the instrument in terms of any ac power line of approx. 115 v. The absolute level of all microphones is checked at several frequencies against a standard microphone, whose calibration is periodically checked by the National Bureau of Standards. Type 1552-A Sound-Level Calibrator is available for making periodic checks on the over-all calibration, including microphone.
- ACCURACY:** The frequency response curves A, B, and C of the Type 1551-A are all within the tolerance specified by the current A.S.A. standards. When the amplifier sensitivity is standardized, the absolute accuracy of sound-level measurements is within ± 1 db for average machinery noises in accordance with the A.S.A. standards.
- TEMPERATURE AND HUMIDITY EFFECTS:** Readings are independent (within 1 db of temperature and humidity) over the ranges of room conditions normally encountered.
- RANGE:** The range of measurement of the pickup and control box when used with the 1551-A or 759-B Sound-Level Meter is approx as follows:
- RMS AMPLITUDE:** 30 micro-inches (min).
 - RMS VELOCITY:** 1000 micro-inches per second (min). The upper limit of velocity and displacement measurements is dependent on the frequency and is determined by the maximum acceleration permissible before non-linearity occurs (10g).
 - RMS ACCELERATION:** 0.3 to 3900 in./sec/sec (10g).

SOUND-LEVEL METER CAG-1551-A

FREQUENCY CHARACTERISTICS: 20 to 1000 cycles per second.

CALIBRATION: The db readings of the sound-level meter can be converted into absolute values of displacement, velocity, or acceleration by means of calibration data, which is supplied with the equipment.

PRESENTATION AND CONTROLS: Vibration pickup plugs into control box, cable connects control box to microphone socket of sound-level meter. Three-position switch on control box determines quantity being measured. Readings are taken on sound-level meter.

RELATION TO OTHER EQUIPMENT:

The General Radio Type 1551-A replaces General Radio Type 759 Sound-Level Meter.

EQUIPMENT REQUIRED BUT NOT SUPPLIED: None.

MAJOR COMPONENTS

QTY	ITEM	STOCK NUMBERS	DIMENSIONS (INCHES)	WEIGHT (LBS)
1	Sound-Level Meter CAG-1551-A includes:		6-5/8 x 8-7/8 x 10-13/16	11 (w/ batt.)
1	Power Cord			
1	Vibration Pick-Up CAG-759-P35		2-1/2 x 3-1/4 x 10-3/4	1
1	Cable		16 lg	3.063
1	Control Box CAG-759-P36		2-1/4 x 3 x 6-3/4	1
2	Technical Manual NAVSHIPS 91959		1/4 x 3-1/2 x 5-1/4	

REFERENCE DATA AND LITERATURE:

NAVSHIPS 91959: Operating Instructions for Type 1551-A Sound-Level Meter.

TUBE, CRYSTAL AND/OR SEMI-CONDUCTOR DATA:

TUBES: (4) CK512AX (3) CK533AX

CRYSTALS: None used.

SEMI-CONDUCTORS: None used.

SHIPPING DATA

PKGS	VOLUME (CU FT)	WEIGHT (LBS)
------	----------------	--------------

CAG-1551-A SOUND-LEVEL METER

PROCUREMENT DATA

PROCURING SERVICE:
SPEC &/OR DWG:

DESIGN COG: Commercial

CONTRACTOR	LOCATION	CONTRACT OR ORDER NO.	APPROX. UNIT COST
General Radio Company Type no. 1551-A	Cambridge, Massachusetts	N0bsr-63137, 7 January 1953	\$520.00

23 April 1962

SOUND-LEVEL METER CAG-1551-B

Cog Service:

FSN: 6625-893-0230

Functional Class:

USA

USN

USAF

TYPE CLASS:

MANUFACTURER'S NAME/CODE NUMBER: General Radio Co.

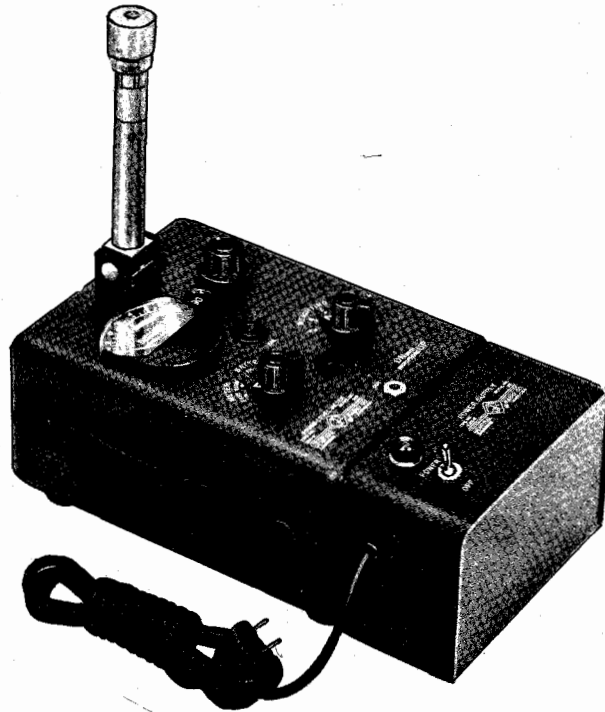

Sound-Level Meter CAG-1551-B

FUNCTIONAL DESCRIPTION:

Sound-Level Meter CAG-1551-B is an accurate, portable instrument for reading, in terms of a standard reference level, the sound pressure level at its microphone.

No field changes in effect at time of preparation (12 July 1961).

TECHNICAL CHARACTERISTICS:

SOUND-LEVEL RANGE: 24 to 150 db above 0.0002 μ bar (0.0002 dyne/cm²) at 1,000 cps.

FREQUENCY-RESPONSE CHARACTERISTICS

A WEIGHTING: 24 to 55 db.

B WEIGHTING: 55 to 85 db.

C WEIGHTING: 85 to 140 db.

MICROPHONE: Rochelle-salt crystal diaphragm type, nondirectional.

SOUND-LEVEL INDICATION: Indicated by algebraic sum of readings of attenuator switch and

CAG-1551-B SOUND-LEVEL METER

Meter range is 16 db, and attenuator is 110 db in 10 db steps.
OUTPUT: 1 v across 20,000 ohms.
ACCURACY: Within porm 1 db for average machinery noise.
POWER REQUIREMENTS: (2) 1.5 v battery, (1) 67.5 v battery.

RELATION TO OTHER EQUIPMENT: None.

EQUIPMENT REQUIRED BUT NOT SUPPLIED:

(2) Battery 1.5 v, (1) Battery 67.5 v.

MAJOR COMPONENTS

QTY	ITEM	STOCK NUMBERS	DIMENSIONS (INCHES)	WEIGHT (LBS)
	Sound-Level Meter CAG-1551-B includes: Vibration Pickup CAG-759-P35 Control Box CAG-759-P36		6-1/8 x 7-1/4 x 9-1/4	7.62 (w/batt)

REFERENCE DATA AND LITERATURE:

Operating Instructions for Type 1551-B Sound Level Meter.

TUBE, CRYSTAL AND/OR SEMI-CONDUCTOR DATA

TUBES: (4) CK512AX (2) CK641P

CRYSTALS: None used.

SEMI-CONDUCTORS: (1) 2N10.

PKGS	VOLUME (CU FT)	WEIGHT(LBS)
------	----------------	-------------

PROCUREMENT DATA

PROCURING SERVICE: DESIGN COG: Commercial
SPEC &/OR DWG:

CONTRACTOR	LOCATION	CONTRACT OR ORDER NO.	APPROX. UNIT COST
General Radio Co. Type no. 1551-B	West Concord, Mass.	N0bsr-85134, 3 February 1960	\$575.99

4.5 CAG-1551-B: 2

FIELD STRENGTH METER

Test-Field Intensity Measuring
I-95-A, I-95-AM,
I-95-B, I-95-BM

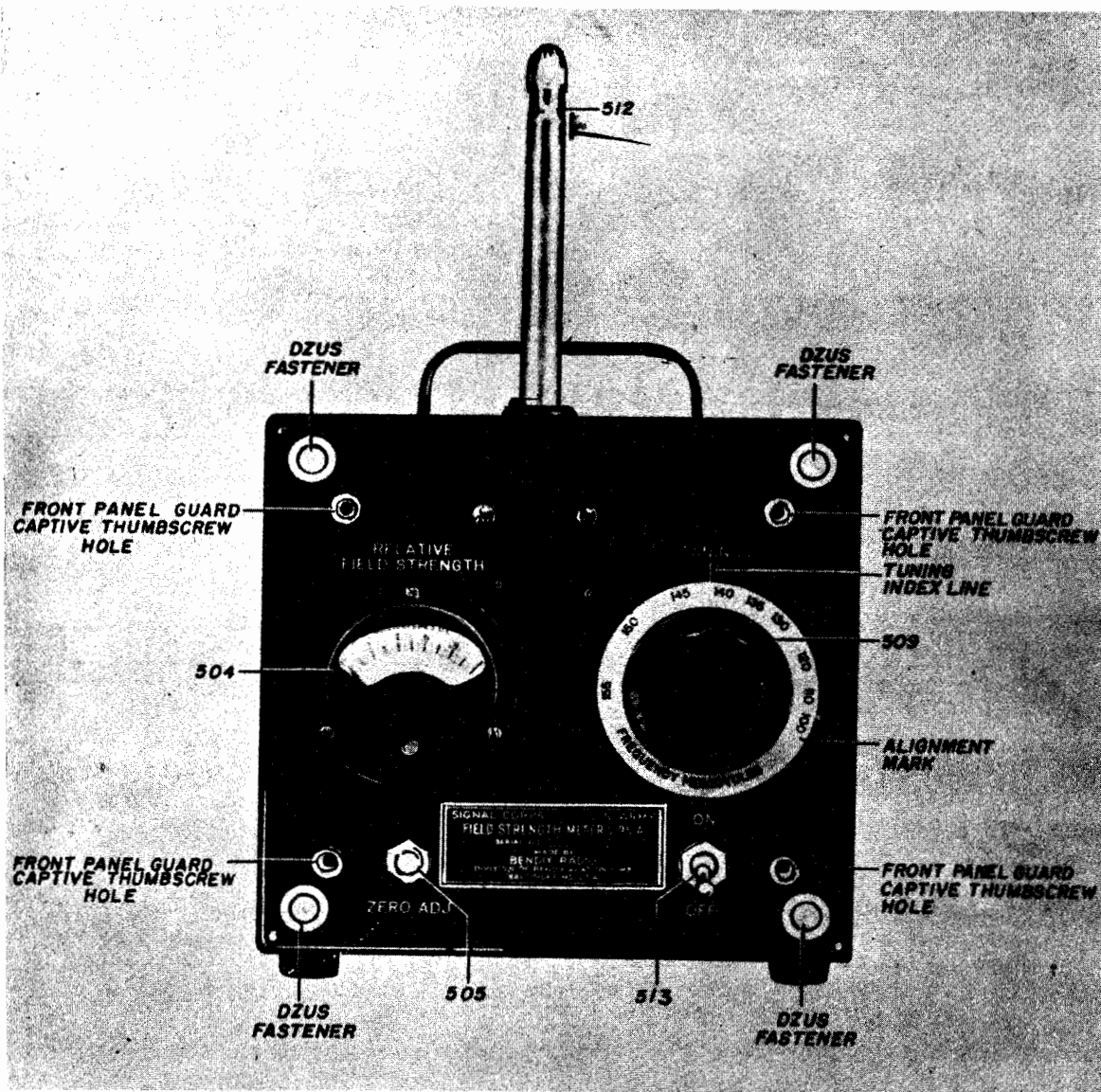

Field Strength Meter I-95-A, -AM, -B, -BM

FUNCTIONAL DESCRIPTION

The I-95-A, I-95-B, I-95-AM or I-95-BM is an uncalibrated vacuum-tube voltmeter designed to indicate the relative field strength and frequency of the radiation from the antenna of Radio Set SCR-522-A or SCR-542-A. This instrument may also be used to indicate modulation of the carrier. The field strength meter consists of a case on which the front panel and rear cover are mounted. A telescopic antenna, a front panel guard and all the electrical components (except the bat-

teries) of the field strength meter are mounted on the front panel.

The batteries, comprising two BA-2 and one BA-23 are not normally supplied with the equipment. A retaining strap for holding these batteries is provided on the inside of the rear cover.

The tuned circuit of the field strength meter may be tuned to any frequency within the range of 100 to 156 mc.

No field changes in effect at time of preparation (17 July 1956).

**I-95-A,I-95-AM,
I-95-B,I-95-BM**

FIELD STRENGTH METER

March 1957

RELATION TO OTHER EQUIPMENT

The above equipments differ from each other only in component parts and in the "Kick-back" characteristic of the meter pointer which has been eliminated in I-95-AM and I-95-BM. This equipment is a part of the IE-12-A and IE-19-A test sets.

Equipment Required but not Supplied: (1) 1-1/2 volt battery, (2) 22-1/2 volt batteries.

ELECTRICAL AND MECHANICAL CHARACTERISTICS

FREQUENCY RANGE: 100 to 156 mc.
 DISTANCE RANGE: Within 25 ft radius.
 POWER SOURCE REQUIRED: (1) 1-1/2 v battery and (2) 22-1/2 v (45 v) batteries.

TUBE AND/OR CRYSTAL COMPLEMENT

(1) 1S5

Total Tubes: (1)

REFERENCE DATA AND LITERATURE

- NAVAER 08-5S-78: Manual of Test Equipment for Airborne Electrical and Electronic Equipment.
- T.O. NO. 16-10-111 (Old T.O. NO. 08-10-111): Technical Manual for Operation and Maintenance of Test Equipment IE-19-A.
- AN-16-401E12-3: Handbook of Maintenance Instructions for Test Equipment IE-12-A and IE-12-T2.

TYPE CLASSIFICATION DESIGN COGNIZANCE BUAER PROCUREMENT COGNIZANCE BUAER STOCK NO. R.D.B. IDENT. NO.
--

EQUIPMENT SUPPLIED DATA

QUANTITY PER EQUIPT	NAME AND NOMENCLATURE	OVERALL DIMENSIONS (inches)	WEIGHT (lbs.)
1	Field Strength Meter-I-95-A,AM,B,BM	7-1/4 X 7-3/8 X 8-1/2	10-1/2
1	Front Panel Guard		

4 March 1963

Cog Service: USN FSN: F6625-629-7051

DISTORTION AND NOISE METER ME-153/U

Functional Class: 5.1

USA

USN

USAF

TYPE CLASS:

Used by

MANUFACTURER'S NAME/CODE NUMBER: General Radio Company, (24655).

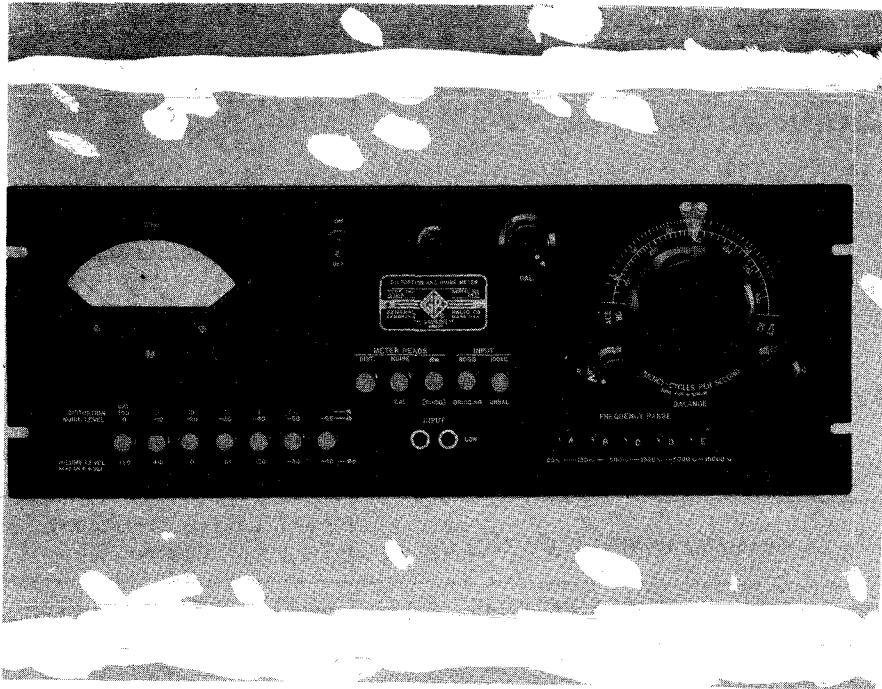

Distortion and Noise Meter ME-153/U

FUNCTIONAL DESCRIPTION:

Distortion and Noise Meter ME-153/U is a portable, general purpose, test equipment used to measure distortion, noise, and hum level in audio frequency circuits. When used in conjunction with a linear detector, the distortion and noise characteristics of broadcast and other radio-telephone transmitters can be measured directly. The meter is calibrated in percentage and decibels; the dial is calibrated in frequency, cycles per second.

No field changes in effect at time of preparation (5 February 1963).

TECHNICAL CHARACTERISTICS:

POWER SUPPLY: 115 or 230 v porm 10%, 50 to 60 cyc, single ph, 65 W.

FREQUENCY RANGE: 50 to 15,000 cps (fundamental), for distortion measurement; 30 to 45,000 cps for noise and hum measurements.

DISTORTION RANGE: Full scale deflection for 0.3%, 1%, 3%, 10%, and 30% distortion.

ME-153/U DISTORTION AND NOISE METER

NOISE MEASUREMENT RANGE: Extends to 80 db below 100% modulation when used in conjunction with a linear rectifier, or 80 db below an audio-frequency signal of 0 dbm level at max sensitivity.

DBM RANGE: P20 to M60 dbm. Full scale values of P20, P10, 0, M10, M20, M30, and M40 dbm are provided. The scale is calibrated in terms of a reference level of one milliwatt in 600 ohms.

INPUT VOLTAGE RANGE

100 KILOHM INPUT: 1.2 to 30 v.

600 OHM INPUT: 0.8 to 30 v.

INPUT IMPEDANCE: 100,000 ohms unbalanced, and 600 ohms bridging input (10,000 ohms), balanced or unbalanced.

RESIDUAL DISTORTION LEVEL

100 KILOHM INPUT: 0.05% max below 7,500 cps. 0.10% max above 7,500 cps.

BRIDGING INPUT: 0.10% max between 50 and 70 cps. 0.05% max between 70 and 7,500 cps. 0.10% max above 7,500 cps.

RESIDUAL NOISE LEVEL: Less than M80 db.

ACCURACY: Porm 5% of full scale, distortion; porm 5% of full scale, noise and dbm.

RELATION TO OTHER EQUIPMENT: None.

EQUIPMENT REQUIRED BUT NOT SUPPLIED: None.

MAJOR COMPONENTS

QTY	ITEM	STOCK NUMBERS	DIMENSIONS (INCHES)	WEIGHT (LBS)
1	Distortion and Noise Meter ME-153/U		7 x 12 x 19	37-3/4
1	Power Cord CAG-CAP-35			
2	Aluminum End Frames			

REFERENCE DATA AND LITERATURE:

NAVSHIPS 93172: Technical Manual for Distortion and Noise Meter ME-153/U.

TUBE, CRYSTAL AND/OR SEMI-CONDUCTOR DATA:

TUBES: (4) 6J5GT (1) 6SN7GT (1) 6K6GT (1) 6H6 (1) 6X5GT (2) OD3

CRYSTALS: None used.

SEMI-CONDUCTORS: None used.

SHIPPING DATA

PKGS	VOLUME (CU FT)	WEIGHT (LBS)
1	5.3	65

4.5 ME-153/U: 2

DISTORTION AND NOISE METER ME-153/U

PROCUREMENT DATA

PROCURING SERVICE: USN
SPEC &/OR DWG:

DESIGN COG: USN, BuShips

CONTRACTOR	LOCATION	CONTRACT OR ORDER NO.	APPROX. UNIT COST
General Radio Company Type no. 1932-A	Cambridge, Mass.	N0bsr-75085	\$650.00

MODIFICATION KIT

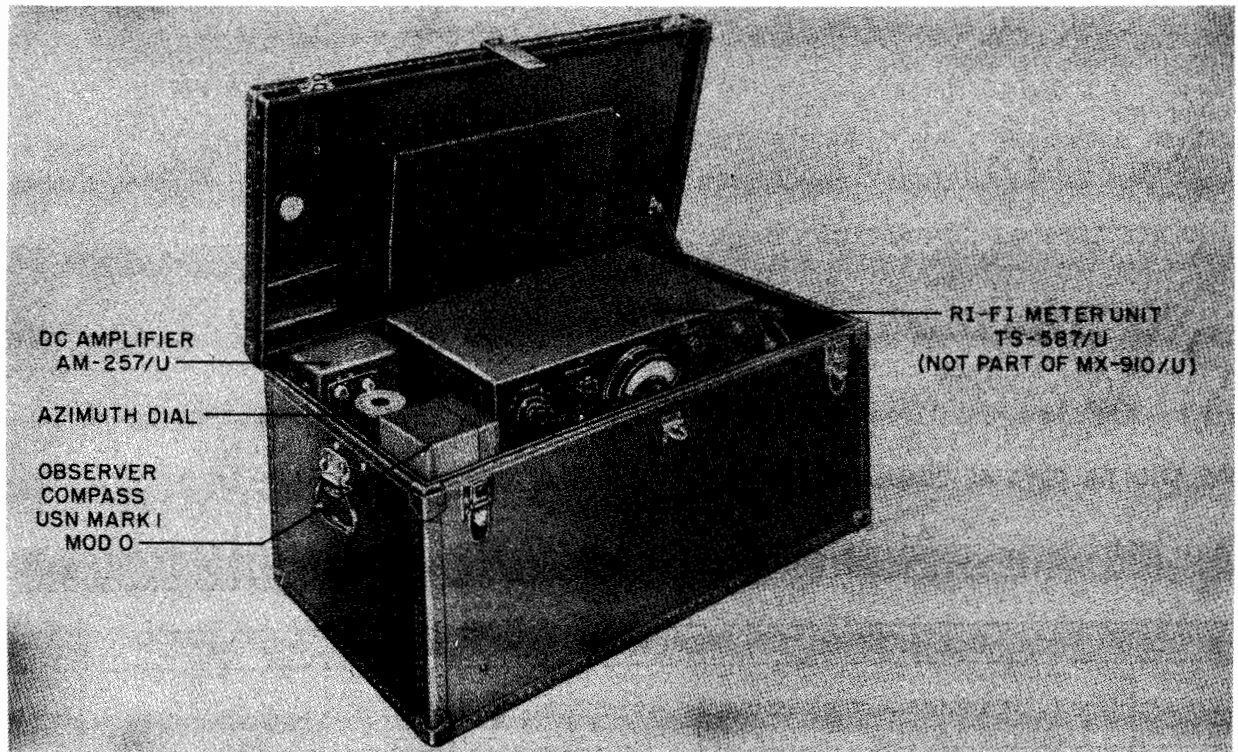

Modification Kit MX-910/U

FUNCTIONAL DESCRIPTION

The MX-910/U is used to modify the Noise-Field Intensity Meter TS-587/U enabling the RI-FI Meter Unit to operate from DC. A DC amplifier is included to amplify the output of the RI-FI Meter to enable it to operate a 0-1 ma recording instrument such as the RD-59/U (not furnished). The Azimuth Circle Assembly permits the reading, directly in degrees of azimuth, of the angular position of the antenna. The Observer Compass USM MK 1 MOD O enables the operator to orient the azimuth dial so that the dial indicates true bearings from magnetic north. A Transit Case CY-673/U which will house all accessories furnished except the Rotary Converter PU-151/U, and which may also be used to house the TS-587/U RI-FI Meter Unit is furnished.

The rotary converter was designed to supply power for the RI-FI instrument only. The added power required for the operation of the DC amplifier and a recorder-milliammeter necessitates approximately 20% overload. Under overload conditions intermittent service only is possible without danger of overheating.

No field changes in effect at time of preparation (6 May 1958).

RELATION TO OTHER EQUIPMENT

The Modification Kit is used with and modifies Noise-Field Intensity Meter TS-587/U.

ELECTRICAL AND MECHANICAL CHARACTERISTICS

ROTARY CONVERTER PU-151/U

INPUT (FULL LOAD): 12 v DC at 17 amp.

OUTPUT

CONTINUOUS: 115 v AC, 60 cps, 100 W, 100% pf.

25% OVERLOAD: Intermittent Duty (5 minutes on 15 minutes off).

HEAT DISSIPATION: 104 W.

SPEED: 3600 rpm.

VOLTAGE REGULATION (FULL LOAD TO NO LOAD): 33%.

TEMPERATURE RISE FOR CONTINUOUS OPERATION: 50° C.

INPUT AND OUTPUT FILTERS: 150 kc to 400 mc, attenuated.

Test-Field Intensity Measuring

MX-910/U

MODIFICATION KIT

DC AMPLIFIER AM-257/U
POWER INPUT: 105 to 125 v AC, 50 to 1600
cps, 17 W.
INPUT IMPEDANCE: 0.1 meg.
OUTPUT IMPEDANCE: 60000 ohms.
AMPLITUDE: 0 to 1 ma.
OBSERVER COMPASS MK 1 MOD 0, BATTERY DRAIN:
0.3 amp at 2.5 v.

No Crystals used.

REFERENCE DATA AND LITERATURE

NAVSHIPS 900990: Appendix 1, Technical
Manual for Noise-Field Intensity Meter
TS-587/U and TS-587A/U.

MANUFACTURER'S OR CONTRACTOR'S DATA

Stoddart Aircraft Radio Co; Hollywood 38,
California.
Contract NObsr-30088, dated 10 May
1948.
Contract NObsr-39372, dated 10 May
1948.

TUBE AND/OR CRYSTAL COMPLEMENT

(1) OA2 (1) OB2
(1) 2C51 (1) 6X4
Total Tubes: (4)

TYPE CLASSIFICATION
DESIGN COGNIZANCE BUSHIPS
PROCUREMENT COGNIZANCE
STOCK NO.
R.D.B. IDENT. NO.

SHIPPING DATA

NUMBER OF BOXES	CONTENTS AND IDENTIFICATION	VOLUME (Cu.Ft.)	OVERALL DIMENSIONS (inches)	WEIGHT PACKED (lbs.)
2	Transit Case CY-673/U containing all units Except Rotary Converter PU-151/U	7.0	17-1/2 X 19-1/4 X 35-3/4	105
1	Rotary Converter PU-151/U	0.7	8-1/2 X 11-1/2 X 12-1/2	27

EQUIPMENT SUPPLIED DATA

QUANTITY PER EQUIPT	NAME AND NOMENCLATURE	OVERALL DIMENSIONS (inches)	WEIGHT (lbs.)
1	Rotary Converter PU-151/U Navy Type-212006	6 X 9 X 10	22
1	Power Cable	72 lg	
1	DC Amplifier AM-257/U	5-1/8 X 6 X 8-1/4	7
1	Power Cable Navy Type 62458 (6 ft)	72 lg	
1	Signal Cable Navy Type 62459 (6 ft 2 in)	74 lg	
1	Plug (AN3106-10SL-35)		
1	Azimuth Dial	2-3/4 X 2-3/4 X 3	0.31
2	Azimuth Dial Pointers	3/4 X 2 X 2	0.13
1	Observer Compass USN MK 1 MOD 0 and Case	4-3/4 X 4-7/8 X 10-7/8	4.75
1	Transit Case CY-673/U	17 X 18-3/4 X 35-1/4	45
2	Technical Manuals Book Supplements Appendix 1, NAVSHIPS 900990		

RADIO INTERFERENCE FIELD INTENSITY METER

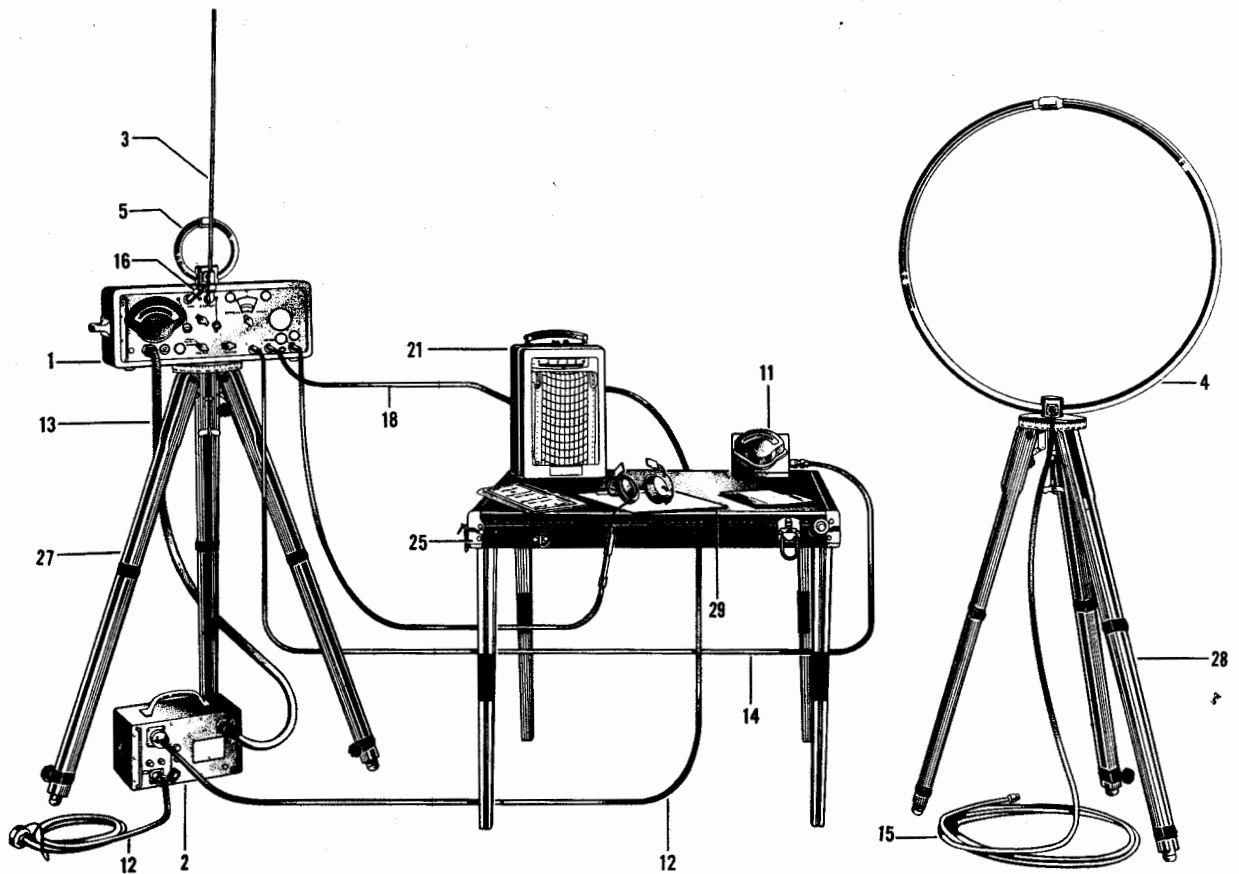

Major Equipment and Accessories NM-10A

FUNCTIONAL DESCRIPTION

The model NM-10A (Stoddart) can be used for radio interference surveys to determine the source of radiated or conducted interference from equipment such as gasoline engine generators, motors or electrical equipment. Field intensity measurement surveys may be made with the NM-10A for adjusting directive antennas or for exploring radiation patterns, where the field intensity may vary over a wide range of values. This equipment can also be used as a frequency selective microvoltmeter.

No field changes in effect at time of preparation (12 June 1956).

ELECTRICAL AND MECHANICAL CHARACTERISTICS

FREQUENCY RANGE: 14 to 250 kc.
INTERMEDIATE FREQUENCY: 12.5 kc.

SELECTIVITY: Band width at 6 db down varies between 100 cps at low frequencies and 600 cps at high frequencies. Band width at 60 db down is 2000 cps.

IMAGE REJECTION: Better than 50 db down from a signal level.

I.F. REJECTION: 60 db.

SENSITIVITY

ELECTROSTATIC PICKUP: 1 uv per meter to 2 v per meter.

ELECTROMAGNETIC PICKUP: 10 uv per meter to 100 v per meter.

TWO TERMINAL VOLTMETER: 1 uv to 1 v

AUDIO SENSITIVITY: 10 uv.

SIGNAL TO NOISE RATIO: Unity

AUDIO CHANNEL OUTPUT: 100 milliwatts.

DYNAMIC RANGE: 20 db.

POWER REQUIREMENTS: 105 to 125 or 210 to 250 v 50 to 1600 cps, single ph.

POWER CONSUMPTION: 100 w.

MANUFACTURER'S OR CONTRACTOR'S DATA

Stoddart Aircraft Radio Co. Hollywood,
California.
Model-NM-10A
Contract NObsr-52336 dated 14 April
1951.
Approximate Cost: \$3500 with equipment
spares.

REFERENCE DATA AND LITERATURE

NAVSHIPS-91548: Technical Manual for Radio
Interference Field Intensity Meter-NM-10A.

TUBE AND/OR CRYSTAL COMPLEMENT

(6) 6AU6 (1) 6J6 (1) 6BE6 (1) 6AL5
(3) 6C4 (1) 6AT6 (1) 6E5 (1) 5Y3GT
(2) OC3/VR-105 (1) 6X4
Total Tubes: (18)

TYPE CLASSIFICATION
DESIGN COGNIZANCE COMMERCIAL
PROCUREMENT COGNIZANCE
STOCK NO.
R.D.B. IDENT. NO.

EQUIPMENT SUPPLIED DATA

QUANTITY PER EQUIPT	NAME AND NOMENCLATURE	OVERALL DIMENSIONS (inches)	WEIGHT (lbs.)
1	Radio Interference-Field Intensity Meter, Frequency NM-10A		
1	Power Supply, A.C.		
1	Rod Antenna, Short and Long		
1	Loop Antenna, Large	30 dia	
1	Loop Antenna, Small	5-3/8 dia	
1	Loop Probe		
1	Line Probe		
3	Matching Impedance		
1	Remote Meter		
2	A.C. Power Cable	72 lg	
1	Power Supply Cable	120 lg	
1	Remote Meter Cable	240 lg	
2	Loop Cable	240 lg	
1	Oscillator Cable	36 lg	
1	Recorder Cable	72 lg	
1	Headphone Extension Cable	240 lg	
1	Cable Adapter, Battery Supply		
1	Esterline-Angus Recorder-0-1MA		
1	Recorder Case		
1	Accessory Case		
1	Transit Case		
1	Loop Case		
1	Tripod Bag		
1	Tripod for NM-10A		
1	Tripod for Loop Antenna-Large		
1	Clip Board		

UNCLASSIFIED

March 1957

Test-Field Intensity Measuring

NOISE AND FIELD INTENSITY METER

NMA-5A

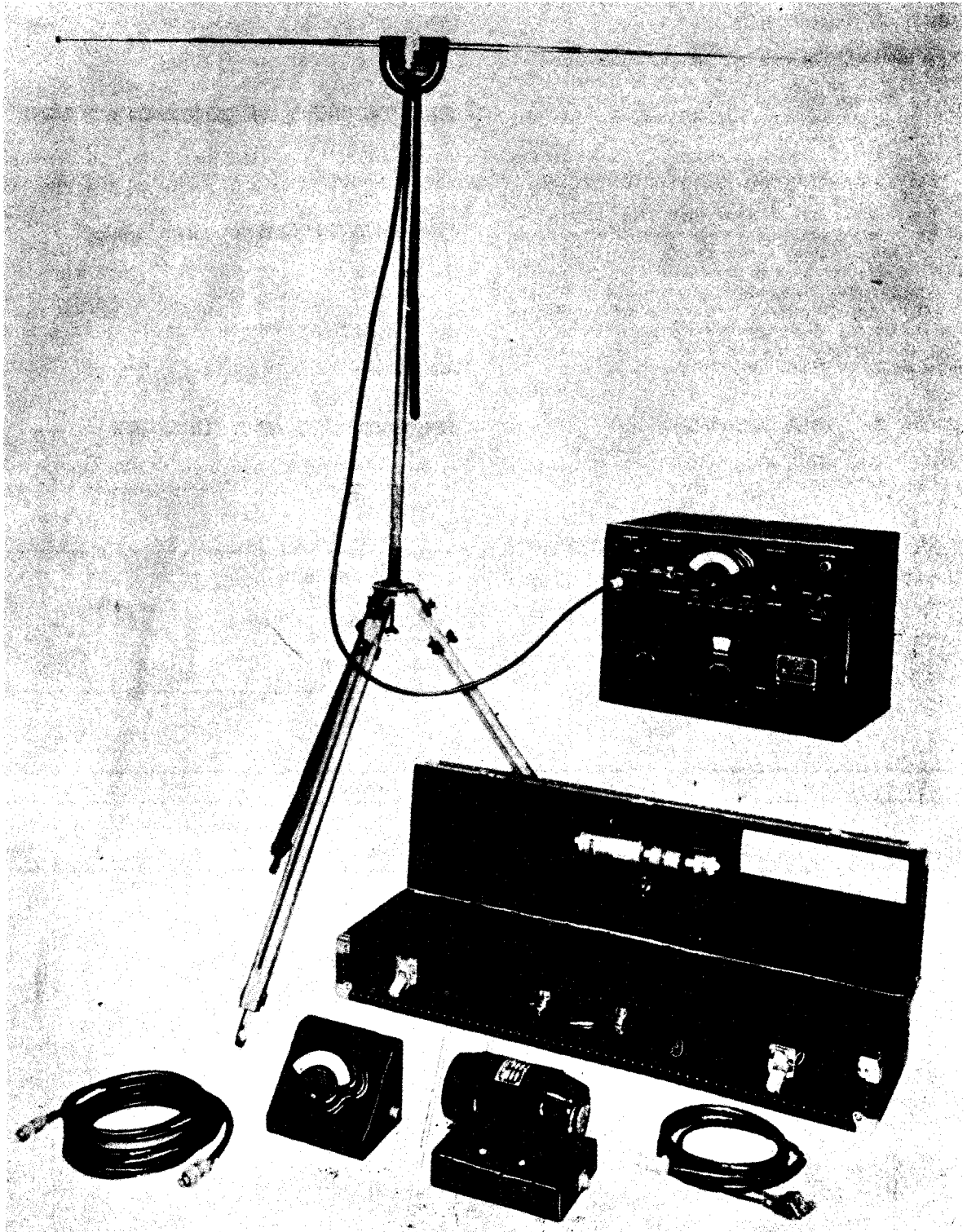

Noise And Field Intensity Meter NMA-5A

UNCLASSIFIED

4.5 NMA-5A: 1

NMA-5A, NOISE AND FIELD INTENSITY METER

FUNCTIONAL DESCRIPTION

The NMA-5A is used to locate radio noise, measure the field intensity of radiated carrier waves and to provide an accurate calibrated receiver for UHF research and development work. A vacuum tube voltmeter indicates the noise intensity in microvolts and decibels and the field intensity in microvolts per meter. An accessory carrying case and a tripod is provided. The tripod is used to mount the dipole antenna for making field strength measurements. A loop probe is used for determining the inductive field existing around various equipment and a line probe for the purpose of measuring conducted noise in DC or AC mains is also included.

No field changes in effect at time of preparation (9 October 1956).

RELATION TO OTHER EQUIPMENT

Similar to Stoddart model NMA-4 except for extended frequency range.

ELECTRICAL AND MECHANICAL CHARACTERISTICS

FREQUENCY RANGE: 88 to 400 mc in 4 bands.

ACCURACY: ±2%.

INDICATOR DATA

TYPE: Microvoltmeter.

RANGE: 0 to 100 uv, -6 to +40 db.

ACCURACY: 1%.

INPUT IMPEDANCE: 95 ohms.

POWER SOURCE: 105 to 125 v, 60 cps, single ph.

MANUFACTURER'S OR CONTRACTOR'S DATA

Stoddart Aircraft Radio Co, Hollywood, California.

TUBE AND/OR CRYSTAL COMPLEMENT

(2) 6J4	(1) 6J6	(1) 9002
(4) 6SG7	(1) 6SQ7	(1) 6H6
(1) 5Y3GT/G	(1) 6L6GA	(1) 6SJ7
(1) 6J5GT/G	(2) 6V6	(1) OD3/VR150

Total Tubes: (17)

REFERENCE DATA AND LITERATURE

Technical Manual for Model NMA-5(88 MC to 400 mc) Noise and Field Intensity Meter.

TYPE CLASSIFICATION	Commercial
DESIGN COGNIZANCE	
PROCUREMENT COGNIZANCE	
STOCK NO.	
R.D.B. IDENT. NO.	

EQUIPMENT SUPPLIED DATA

QUANTITY PER EQUIPT	NAME AND NOMENCLATURE	OVERALL DIMENSIONS (inches)	WEIGHT (lbs.)
1	Noise and Field Intensity Meter NMA-5A	14-9/16 x 15-3/16 x 21-1/2	57.5
1	Power Cable	6 ft lg	.57
1	R.F. Transmission Line	6 ft lg	.68
1	R.F. Transmission Line	25 ft lg	2.25
1	Loop Probe		.2
1	Line Probe		.53
1	Adjustable Dipole Antenna		2.63
1	Collapsible Tripod		4.37
1	External Microvoltmeter		2.44
1	External Meter Cable	25 ft lg	2.25
1	Rotary Converter 110 v AC output		15.
1	Converter Battery Cable	6 ft lg	1.06
1	Matching Impedance		.22
1	Accessory Case (empty)	6-5/16 x 12 x 38-3/4	21.
1	Technical Manual		.56

March 1957

NOISE AND FIELD INTENSITY METER EQUIPMENT

OCV

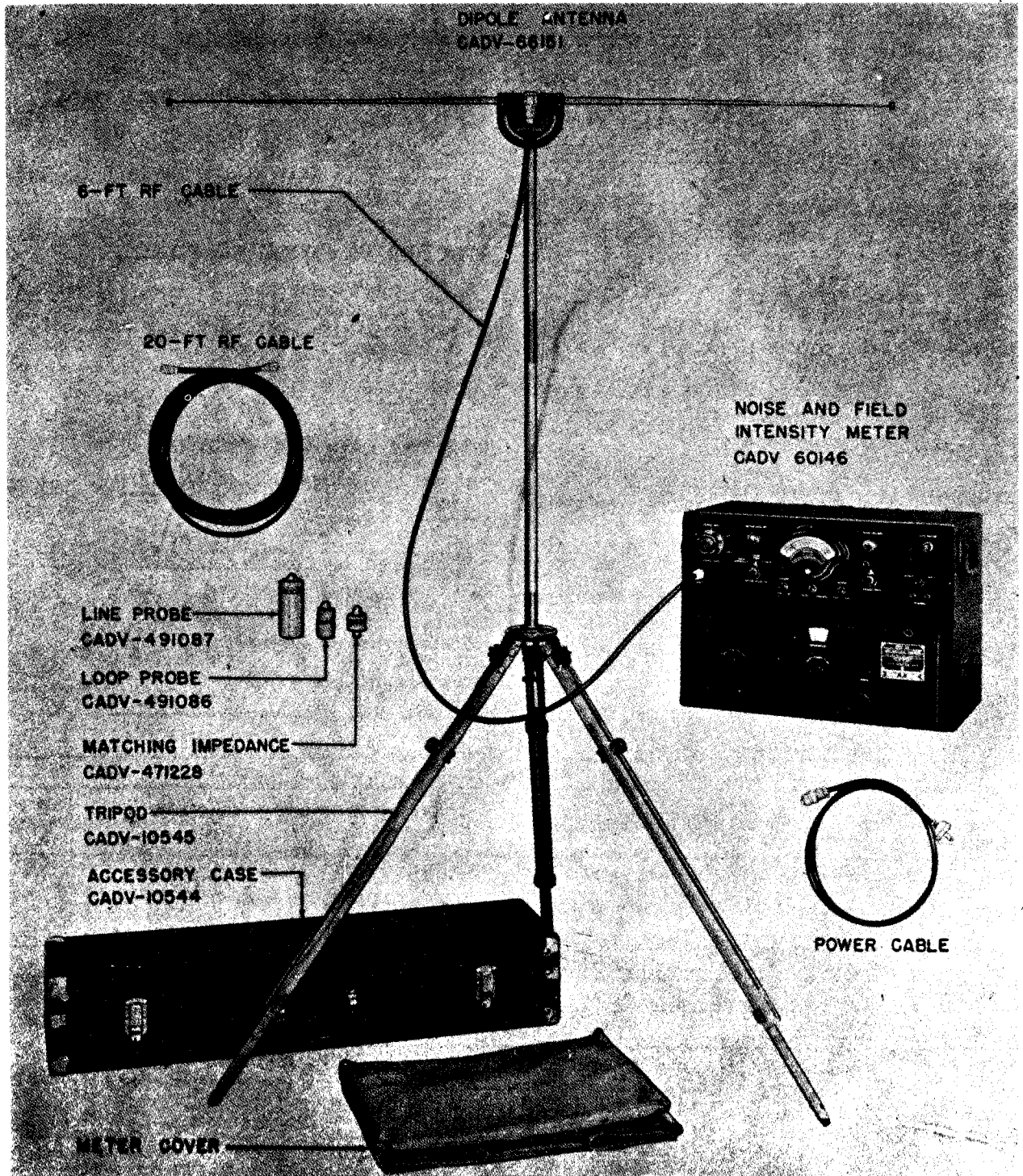

Noise and Field Intensity Meter Equipment OCV

OCV NOISE AND FIELD INTENSITY METER EQUIPMENT

March 1957

FUNCTIONAL DESCRIPTION

The Model OCV is a high sensitivity radio receiver used to measure and locate radio noise and to make field strength measurements in the 100 to 400 megacycle portion of the radio spectrum. Essentially, it is a two terminal voltmeter with sufficient amplification and selectivity to indicate the intensity of radio noise or the field strength of radiated signals. Proper use of the specially designed antennas furnished with the equipment will enable the operator to determine the source of the signal, the first and most important step in the eventual elimination of interfering radio noise.

The equipment consists of one conveniently transportable metal cabinet and a carrying case containing the accessories, such as antennas, connecting cables packed in a separate carrying case.

No field changes in effect at time of preparation (8 October 1956).

ELECTRICAL AND MECHANICAL CHARACTERISTICS

FREQUENCY RANGE: 100 to 400 mc.
 SENSITIVITY: 5 uv min and 25 uv min from 100 to 105 mc.
 SELECTIVITY: 120 kc bandwidth at 6 db down.
 IMAGE FREQUENCY RESPONSE: Flat ±3 db over the range from 300 to 3000 cps.
 IMPEDANCE
 INPUT: 100 ohms.
 OUTPUT: 4000 or 300 ohms.
 POWER SOURCE: 105 to 125 v, 50 to 60 cps,

single ph, 98 W.
 POWER FACTOR: 0.88.

MANUFACTURER'S OR CONTRACTOR'S DATA

Stoddard Aircraft Radio Co., Hollywood, California.
 Contract NXsr 88869, dated 1 January 1945.

TUBE AND/OR CRYSTAL COMPLEMENT

(1) 5Y3GT/G	(2) 6J4	(1) 6SQ7
(1) 6J5GT/G	(1) 6J6	(1) 6H6
(1) OD3/VR150	(1) 9002	(1) 6SJ7
(1) 6L6GA	(4) 6SG7	(2) 6V6

Total Tubes: (17).

REFERENCE DATA AND LITERATURE

Technical Manual for Noise and Field Intensity Meter Equipment Navy Model OCV.

TYPE CLASSIFICATION	
DESIGN COGNIZANCE	BUSHIPS
PROCUREMENT COGNIZANCE	
STOCK NO.	
R.D.B. IDENT. NO.	

SHIPPING DATA

NUMBER OF BOXES	CONTENTS AND IDENTIFICATION	VOLUME (Cu.Ft.)	OVERALL DIMENSIONS (inches)	WEIGHT PACKED (lbs.)
1	OCV Noise and Field Intensity Meter	17.9	23-1/2 X 29-1/2 X 44-1/2	236

EQUIPMENT SUPPLIED DATA

QUANTITY PER EQUIPT	NAME AND NOMENCLATURE	OVERALL DIMENSIONS (inches)	WEIGHT (lbs.)
1	OCV Noise and Field Intensity Meter NT-60146	14-9/16 X 15-3/16 X 21-1/2	64
1	Accessory Case NT-10544 Containing the following:	6-15/16 X 12 X 38-3/4	37
1	Dipole Antenna NT-66151		
1	Loop Probe NT-491086		
1	Line Probe NT-491087		
1	Antenna Tripod NT-10545		
1	Matching Impedance NT-471228		
2	6 ft cables		
1	20 ft cable		

December 1956

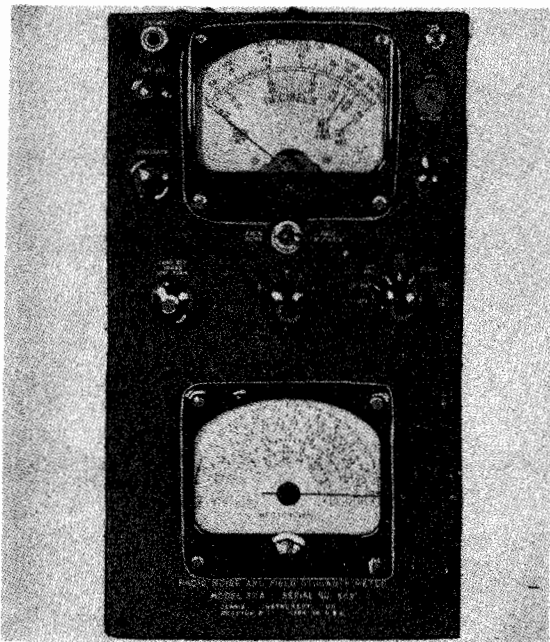
INTERFERENCE LOCATING EQUIPMENT**OF***Interference Locating Equipment***FUNCTIONAL DESCRIPTION**

The OF is a portable instrument for use in measuring radio noise voltages, radio noise and radio transmitter field intensities.

No field changes in effect at time of preparation (22 June 1956).

RELATION TO OTHER EQUIPMENT

Similar to Models OF-1 and OF-2.

ELECTRICAL AND MECHANICAL CHARACTERISTICS

FREQUENCY RANGE: 150 to 18000 kc in 4 bands.
SENSITIVITY: 10 to 10000 mv.

POWER REQUIREMENTS: Battery 3 v at 420 ma;
Battery 135 v at 15 ma; Vibrator Power
Pack Battery 6 v, at 3 amp; AC Power Pack
115 v, 60 cps, 10 W.

MANUFACTURER'S OR CONTRACTOR'S DATA

Ferris Instrument Co., Boonton, New
Jersey.

Contract: NOs 61598.

TUBE AND/OR CRYSTAL COMPLEMENT

(1) 1N5GT	(3) 1D5GP
(1) 1C6	(1) 1H4G
(1) 1E1	(1) 30

Total Tubes: (8)

REFERENCE DATA AND LITERATURE

NAVSHIPS 900,155: Electronic Test Equipment
Handbook, Volume II. Ferris Catalog #49.

TYPE CLASSIFICATION
DESIGN COGNIZANCE BUSHIPS
PROCUREMENT COGNIZANCE
STOCK NO.
R.D.B. IDENT. NO.

SHIPPING DATA

NUMBER OF BOXES	CONTENTS AND IDENTIFICATION	VOLUME (Cu.Ft.)	OVERALL DIMENSIONS (inches)	WEIGHT PACKED (lbs.)
1	Interference Locating Equipment OF	0.85	8-1/4 x 12-1/4 x 14-1/2	28

EQUIPMENT SUPPLIED DATA

QUANTITY PER EQUIPT	NAME AND NOMENCLATURE	OVERALL DIMENSIONS (inches)	WEIGHT (lbs.)
1	Radio Interference Locator NT-60029	7 x 12 x 13-1/4	22
1	Antenna NT-66038	4 1 lg	
1	Battery		
1	Calibration Charts (set)		
1	Instruction Book		
1	Carrying Strap		

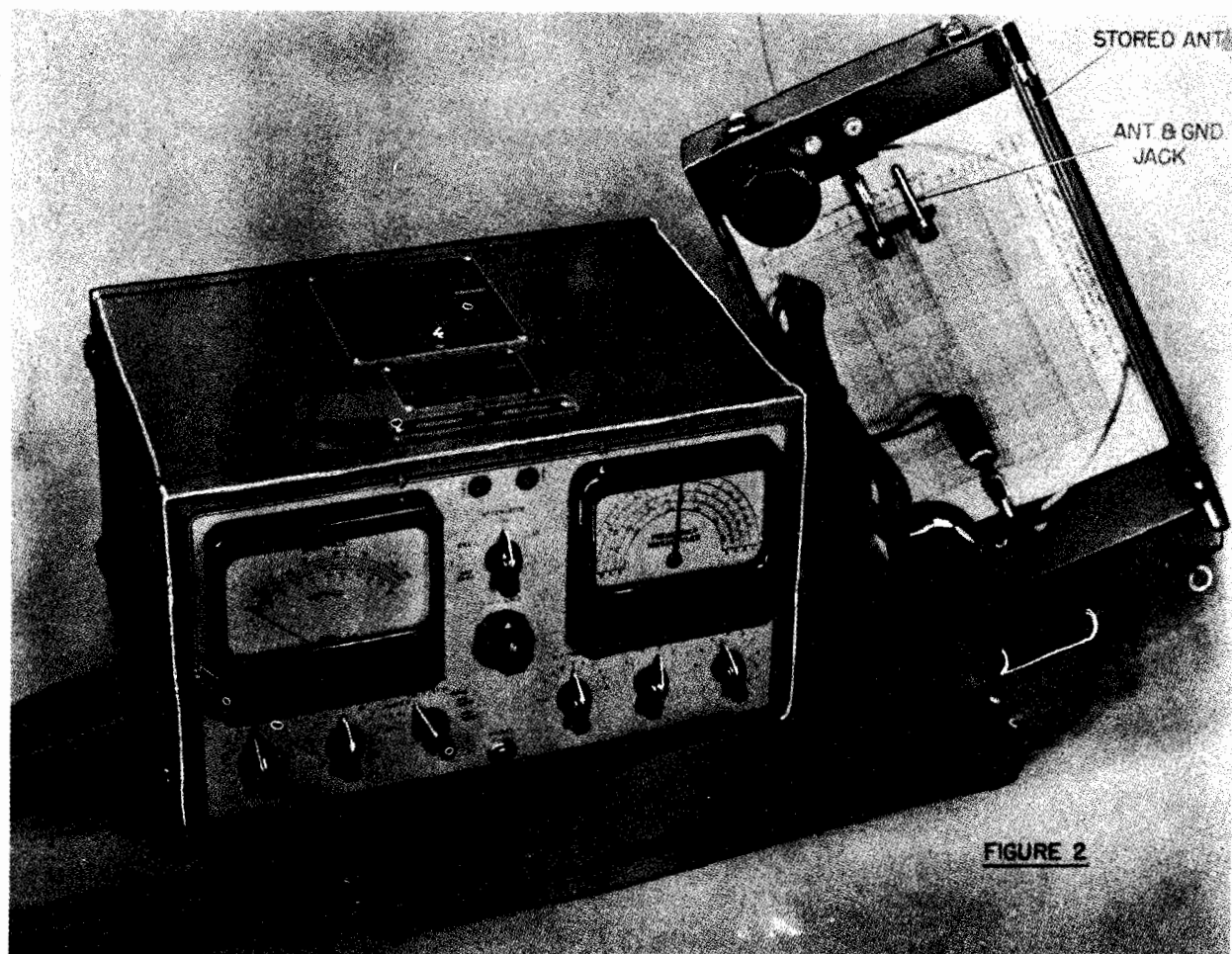
INTERFERENCE LOCATING EQUIPMENT**OF-1****FIGURE 2***Interference Locating Equipment OF-1***FUNCTIONAL DESCRIPTION**

The OF-1 is designed to serve as a portable instrument for use in the measurement of radio noise voltages, radio noise and radio transmitter field intensities.

No field changes in effect at time of preparation (22 June 1956).

RELATION TO OTHER EQUIPMENT

Similar to Model OF and OF-2.

Equipment Required but not Supplied: (2) Burgess type 4FH, 1.5 volt dry "A" batteries, (2) Burgess type 5308, 45 volt dry "B" batteries, (4) Burgess type 5360, 4.5 volt

dry "C" batteries, (3) Burgess type Z Uni-cell, 1.5 volt dry bucking/bias batteries.

ELECTRICAL AND MECHANICAL CHARACTERISTICS

FREQUENCY RANGE: 135 to 360 kc and 530 kc to 17.5 mc.

SENSITIVITY: 10 to 100000 mv.

POWER REQUIREMENTS: Battery 90 v, Battery 13.5 v, Battery 4.5 v, Battery 3 v.

MANUFACTURER'S OR CONTRACTOR'S DATA

Fada Radio and Electric Co., Long Island, N.Y.

Contract NOs-98986 dated 16 February 1942.

OF-1

INTERFERENCE LOCATING EQUIPMENT

December 1956

TUBE AND/OR CRYSTAL COMPLEMENT

OF-1 Interference Locating Equipment

(3) 1D5GP (1) 1C6 (1) 1H4G
 (1) 30 (1) 1N5G (1) 1P1
 Total Tubes: (8)

TYPE CLASSIFICATION
 DESIGN COGNIZANCE BUSHIPS
 PROCUREMENT COGNIZANCE
 STOCK NO.
 R.D.B. IDENT. NO.

REFERENCE DATA AND LITERATURE

NAVSHIPS 95179: Technical Manual for Model

EQUIPMENT SUPPLIED DATA

QUANTITY PER EQUIPT	NAME AND NOMENCLATURE	OVERALL DIMENSIONS (inches)	WEIGHT (lbs.)
1	Radio Interference Locating Unit NT-60029	8-3/8 X 12-1/4 X 14-5/8	31
1	Whip Antenna NT-CPS-66038	26-5/16	
1	Web Carrying Strap	66-1/2	
1	Antenna-Ground Plug Unit	1/2 X 1-3/4 X 1-7/8	

December 1956

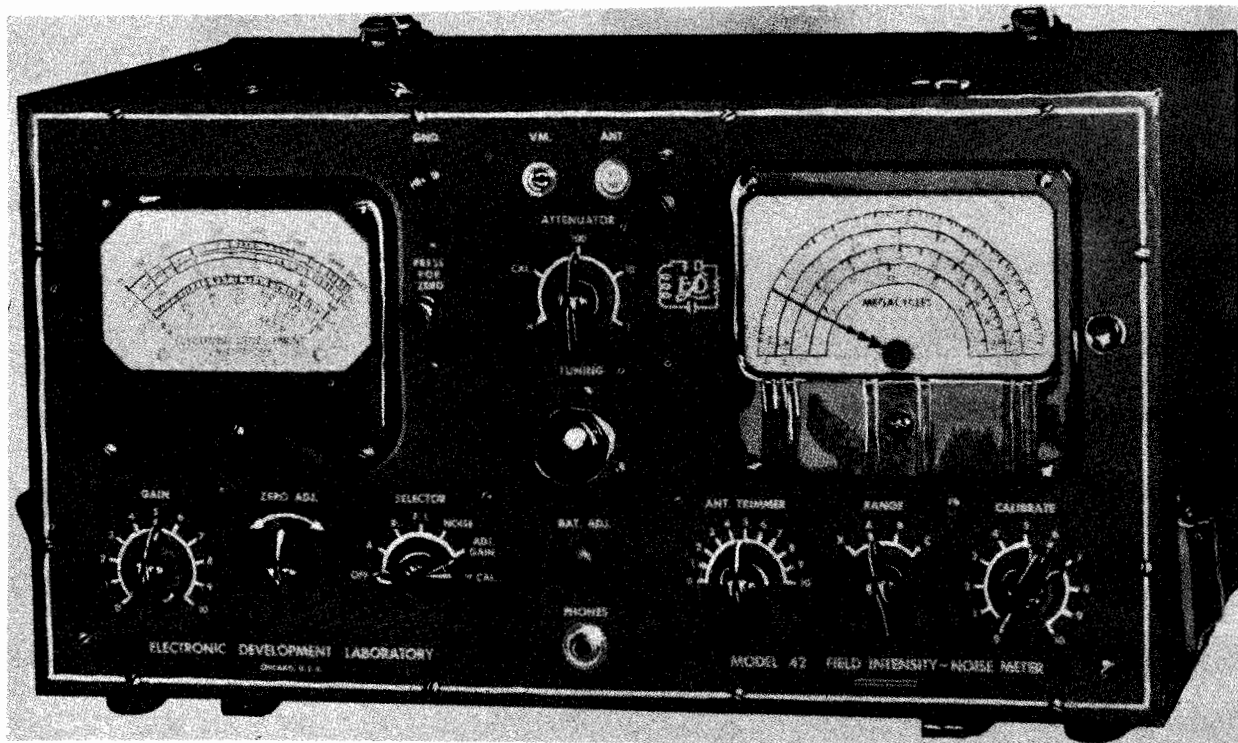
INTERFERENCE LOCATING EQUIPMENT**OF-2***Interference Locating Equipment OF-2***FUNCTIONAL DESCRIPTION**

The OF-2 is a portable instrument designed to measure radio noise voltages, radio noise and radio transmitter field intensities. It may also be used as a two-terminal voltmeter.

No field changes in effect at time of preparation (22 June 1956).

RELATION TO OTHER EQUIPMENT

Similar to Model OF and OF-1.

Equipment Required but not Supplied: (1)
Headset (600 ohm).

ELECTRICAL AND MECHANICAL CHARACTERISTICS

FREQUENCY RANGE: 150 to 350 kc, 540 kc to 20 mc.

SENSITIVITY: 10 to 10000 mv.

POWER REQUIREMENTS: (3) Batteries 45 v. (4)
Batteries 4.5 v, (4) Batteries 1.5 v.

MANUFACTURER'S OR CONTRACTOR'S DATA

Electronic Development Laboratory, Chicago, Illinois.

Contract NXss-22302 dated 1 February 1943.

Contract NXsr-56775 dated 14 April 1944.

TUBE AND/OR CRYSTAL COMPLEMENT

(1) 1LC6	(1) 1S5	(1) 3A5
(2) 1LE3	(3) 1T4	

Total Tubes: (8)

TYPE CLASSIFICATION
DESIGN COGNIZANCE BUSHIPS
PROCUREMENT COGNIZANCE
STOCK NO.
R.D.B. IDENT. NO.

UNCLASSIFIED

4.5 OF-2: 1

OF-2

INTERFERENCE LOCATING EQUIPMENT

December 1956

EQUIPMENT SUPPLIED DATA

QUANTITY PER EQUIPT	NAME AND NOMENCLATURE	OVERALL DIMENSIONS (inches)	WEIGHT (lbs.)
1	Radio Interference Locator Field Strength Meter NT-60112	9-5/32 x 14-1/8 x 16-3/4	34
1	Rod Antenna NT-66144		

PICK-UP ASSEMBLY**TS-131/AP**BOX CONTAINING STUDS
AND SPARE CRYSTALS

CASE CY-108/AP

CORD CX-149/AP

ADAPTER
M-359CONTROL BOX
C-III/APPICK-UP ASSEMBLY TS-131/AP
(LESS ACCESSORIES)*Pick-Up Assembly TS-131/AP***FUNCTIONAL DESCRIPTION**

Pick-up Assembly TS-131/AP is a test unit used in indicating the relative output of an airborne transmitting antenna.

No field changes in effect at time of preparation (13 July 1959).

MANUFACTURER'S OR CONTRACTOR'S DATA

Cover Dual Co., Chicago, Illinois.

Order No. 649-44, dated 22 February 1944.

Order No. 659-DAY-44.

Order No. 985-44, dated 18 September 1944.

EQUIPMENT REQUIRED BUT NOT SUPPLIED

(2) Test Set I-139-A.

TUBE AND/OR CRYSTAL COMPLEMENT

No Electron Tubes used.

ELECTRICAL AND MECHANICAL CHARACTERISTICS

FREQUENCY RANGE: 20 to 1,000 mc.

(3) 1N21B

Total Crystals: (3)

Test-Field Intensity Measuring

TS-131/AP

PICK-UP ASSEMBLY

REFERENCE DATA AND LITERATURE

AN 08-35TS131-2: Technical Manual for PICK-UP ASSEMBLY TS-131/AP.

TYPE CLASSIFICATION DESIGN COGNIZANCE USAF, WADC PROCUREMENT COGNIZANCE USAF SPEC 71-5051 STOCK NO. R.D.B. IDENT. NO. 5.1

SHIPPING DATA

NUMBER OF BOXES	CONTENTS AND IDENTIFICATION	VOLUME (Cu.Ft.)	OVERALL DIMENSIONS (inches)	WEIGHT PACKED (lbs.)
1	Pick-up Assembly TS-131/AP	0.5	8 X 9 X 12	9.5

EQUIPMENT SUPPLIED DATA

QUANTITY PER EQUIPT	NAME AND NOMENCLATURE	OVERALL DIMENSIONS (inches)	WEIGHT (lbs.)
1	Pick-up Assembly TS-131/AP Including:	1 X 4 X 6-1/2	0.3
1	Control Box C-111/AP	1-27/32 X 2 X 2-11/32	0.4
1	Cord CX-149/AP	420 lg	0.8
1	Case CY-108/AP	5-11/16 X 6-5/16 X 9-7/8	
1	Adapter M-359		0.1
4	Snap Slide Stud		
3	Spare Crystal 1N21B		

FLUXMETER

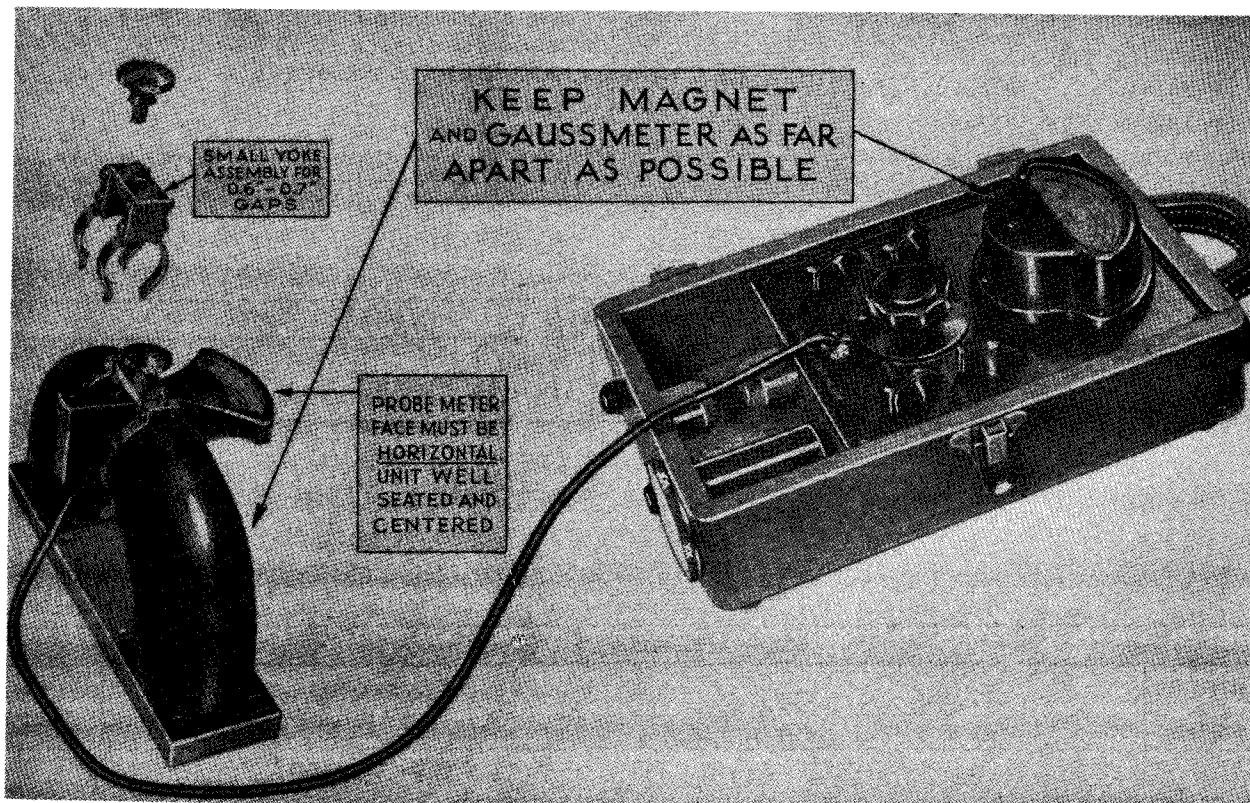

Fluxmeter TS-15/AP

FUNCTIONAL DESCRIPTION

The TS-15/AP, TS-15A/AP and TS-15B/AP are portable equipment used in measuring flux densities between pole faces of magnets employed in oscillatory circuits of X-band and S-band transmitters.

No field changes in effect at time of preparation (25 April 1958).

RELATION TO OTHER EQUIPMENT

Equipment Required but not Supplied: (1) Battery BA-30.

ELECTRICAL AND MECHANICAL CHARACTERISTICS

FLUX DENSITY RANGE

TS-15/AP: 1,200 to 2,300 gauss; 1,700 to 3,200 gauss; 2,400 to 4,500 gauss.

TS-15A/AP: 1,200 to 2,400 gauss; 2,400 to 4,800 gauss; 4,800 to 9,600 gauss.

ACCURACY: $\pm 2\%$.

POWER REQUIREMENTS: 1.5 v DC.

MANUFACTURER'S OR CONTRACTOR'S DATA

Marion Electrical Instrument Co, Manchester, N.H.
Contract NXss-21899, dated August 1944 (TS-15A/AP).

TUBE AND/OR CRYSTAL COMPLEMENT

No Electron Tubes or Crystals used.

REFERENCE DATA AND LITERATURE

TM11-2559: Technical Manual for Fluxmeters TS-15/AP, TS-15A/AP, and TS-15B/AP.

AN16-35TS15-2: Maintenance Instructions for Fluxmeter TS-15A/AP.

TYPE CLASSIFICATION
DESIGN COGNIZANCE TASSA
PROCUREMENT COGNIZANCE
STOCK NO.
R.D.B. IDENT. NO.

**TS-15/AP, TS-15A/AP,
TS-15B/AP** **FLUXMETER**

SHIPPING DATA

NUMBER OF BOXES	CONTENTS AND IDENTIFICATION	VOLUME (Cu.Ft.)	OVERALL DIMENSIONS (inches)	WEIGHT PACKED (lbs.)
1	Fluxmeter TS-15/AP, TS-15A/AP or TS-15B/AP	0.47	7 X 9 X 13	9

EQUIPMENT SUPPLIED DATA

QUANTITY PER EQUIPT	NAME AND NOMENCLATURE	OVERALL DIMENSIONS (inches)	WEIGHT (lbs.)
1	TS-15/AP Fluxmeter TS-15/AP including:	4-1/2 X 6 X 10	6.5
1	Probe Meter		
1	Yoke Assy		
2	Technical Manual TM11-2559		
1	TS-15A/AP Fluxmeter TS-15A/AP including:	4-1/2 X 6 X 10	6.5
1	Probe Meter	2-3/16 X 1-1/2 X 1-13/16	
1	Yoke Assy	1 X 1-1/16 X 1-11/16	
1	Adapter 0.55 gap		
1	Adapter 1.51 gap		
2	Technical Manual		
1	TS-15B/AP Fluxmeter TS-15B/AP including:	4-1/2 X 6 X 10	6.5
1	Probe Meter	1-1/2 X 1-13/16 X 2-3/16	
1	Yoke Assy	1 X 1-1/16 X 1-11/16	
1	Handle	3/4 dia X 5-3/4	
1	Adapter Nut	3/8 X 5/8	
2	Technical Manuals		

April 1959

Test-Field Intensity Measuring

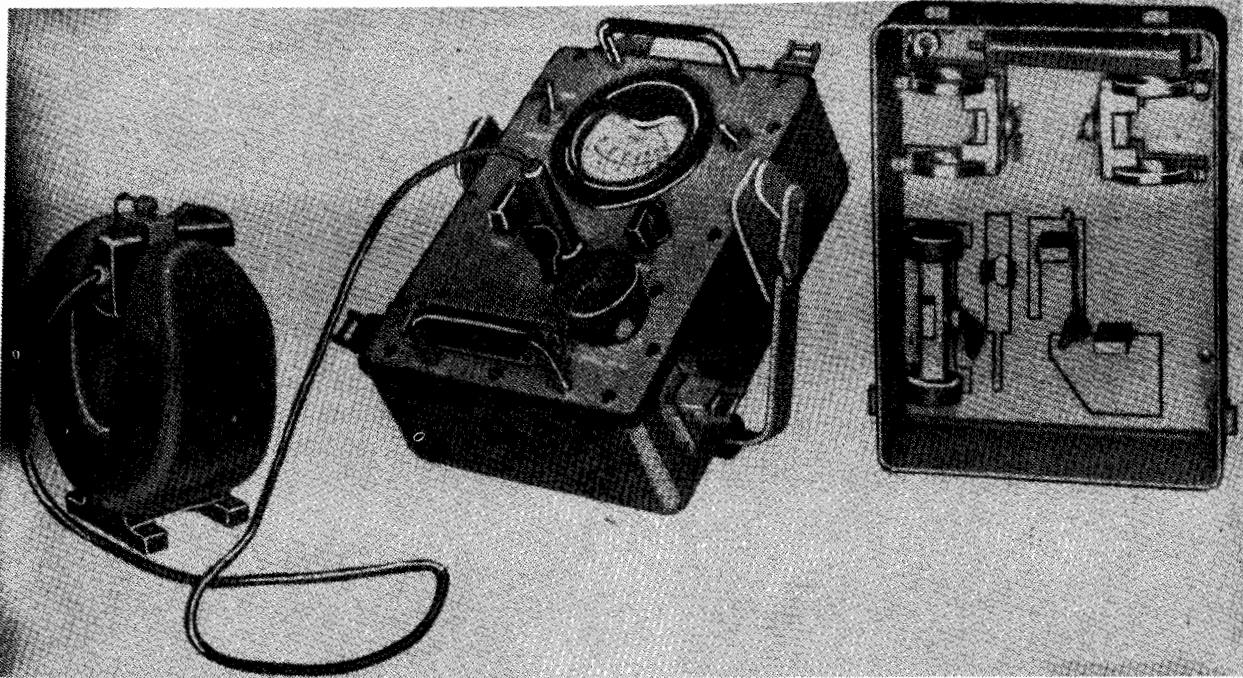
FLUXMETER**TS-15C/AP***Fluxmeter TS-15C/AP***FUNCTIONAL DESCRIPTION**

The TS-15C/AP is a portable test set, designed specifically to provide quantitative measurements of the flux densities in magnets. It can be used to measure magnetic flux densities in the range of 1200 to 9600 gauss from any source.

No field changes in effect at time of preparation (23 October 1958).

RELATION TO OTHER EQUIPMENT

Similar to TS-15/AP, TS-15A/AP and TS-15B/AP except for differences in dimensions, material of case and handle, measurement ranges and quantity of probe meter adapters.

EQUIPMENT REQUIRED BUT NOT SUPPLIED

(1) Battery BA-30.

ELECTRICAL AND MECHANICAL CHARACTERISTICS

MEASUREMENT RANGES: 1200 to 2400 gauss, 2400 to 4800 gauss, 4800 to 9600 gauss.
OPERATING POWER REQUIRED: 1.5 v DC battery.

TUBE AND/OR CRYSTAL COMPLEMENT

No Electron Tubes or Crystals used.

REFERENCE DATA AND LITERATURE

TM-11-2559A: Technical Manual for Fluxmeter TS-15C/AP.

TYPE CLASSIFICATION

DESIGN COGNIZANCE TASSA

PROCUREMENT COGNIZANCE

STOCK NO.

R.D.B. IDENT. NO. 5.8

Apr 11 1959

Test-Field Intensity Measuring

TS-15C/AP

FLUXMETER

SHIPPING DATA

NUMBER OF BOXES	CONTENTS AND IDENTIFICATION	VOLUME (Cu.Ft.)	OVERALL DIMENSIONS (inches)	WEIGHT PACKED (lbs.)
1	Fluxmeter TS-15C/AP	0.5	8-1/2 X 9 X 10-1/2	9.5

EQUIPMENT SUPPLIED DATA

QUANTITY PER EQUIPT	NAME AND NOMENCLATURE	OVERALL DIMENSIONS (inches)	WEIGHT (lbs.)
1	Fluxmeter TS-15C/AP	6 X 6-1/2 X 8-1/2	6
1	Test Set Adapter MX-1028/U		
1	Test Set Adapter MX-915/U	1.5 X 1-7/8 X 2	
1	Adapter for 7/8 in. to 1-1/8 in. Pole face dia and 0.6 in. to 0.7 in. Gap	1 X 1-3/32 X 1-11/16	
1	Adapter for 1.5 in. to 2.0 in. Pole face dia 1.3 in. to 1.5 in. Gap	1.5 X 1-13/16 X 2	
1	Handle	3/4 dia X 5-1/4	
1	Probe Meter	1-5/8 X 1-3/4 X 2-5/8	

FIELD INTENSITY METER

TS-153/AP



Field Intensity Meter TS-153/AP

OPERATING RADIUS: 22 ft.
POWER REQUIREMENTS: 1.5 v DC, 67.5 v DC,
15 W.

MANUFACTURER'S OR CONTRACTOR'S DATA

Freed Radio Corp, NY, NY.
Contract: NOas-3100.
NOas-4185.
Approximate Cost: \$65.00 with equip-
ment spares.

TUBE AND/OR CRYSTAL COMPLEMENT

(1) 1S5
Total Tubes: (1)
No Crystals used.

REFERENCE DATA AND LITERATURE

NAVSHIPS 93003, Vol 1: Technical Manual for
Electronic Test Equipment.

FUNCTIONAL DESCRIPTION

The TS-153/AP is used in determining relative field strength carrier modulation and frequency of transmitters.

No field changes in effect at time of preparation (17 April 1958).

RELATION TO OTHER EQUIPMENT

Equipment Required but not Supplied: (4)
Battery NT-19031, (2) Battery NT-19032.

ELECTRICAL AND MECHANICAL CHARACTERISTICS

FREQUENCY RANGE: 62 to 72.5 mc.

<p>TYPE CLASSIFICATION DESIGN COGNIZANCE BUSHIPS PROCUREMENT COGNIZANCE STOCK NO. R.D.B. IDENT. NO.</p>

EQUIPMENT SUPPLIED DATA

QUANTITY PER EQUIPT	NAME AND NOMENCLATURE	OVERALL DIMENSIONS (inches)	WEIGHT (lbs.)
1	Field Intensity Meter TS-153/AP	7-1/4 x 7-1/4 x 8-1/2	10.7

UNCLASSIFIED

January 1958

Test-Field Intensity Measuring

RADIO INTERFERENCE TESTER

TS-277/AR

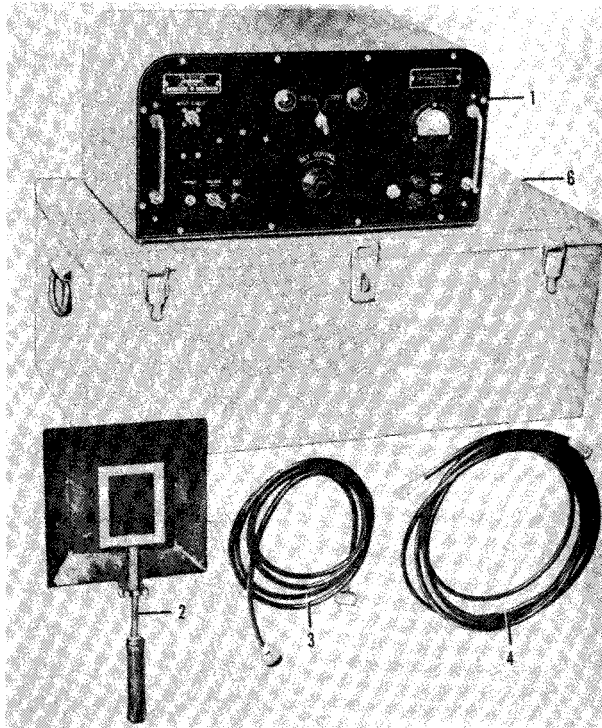

Radio Interference Tester

FUNCTIONAL DESCRIPTION

The TS-277/AR is primarily intended for seeking and isolating objectionable RF interference emanating from aircraft engines. It is designed for the purpose of detecting, with a view toward eliminating, the objectionable electrical interferences occurring in the 950 to 1150 megacycle frequency range. It is further used to provide indications of the level of RF interference in excess of

the current local or ambient interference level.

No field changes in effect at time of preparation (12 July 1957).

ELECTRICAL AND MECHANICAL CHARACTERISTICS

FREQUENCY RANGE: 950 to 1150 mc.

INTERMEDIATE FREQUENCY DATA

FREQUENCY: 30 mc.

BANDWIDTH: 3.3 mc.

IF AND VIDEO GAIN: 100 db over-all.

INPUT IMPEDANCE: 50 ohms.

POWER REQUIREMENTS: 115 v, 60 cps, single ph, 250 W.

TUBE AND/OR CRYSTAL COMPLEMENT

- | | |
|----------|------------|
| (1) OD3 | (2) 6AG7 |
| (1) 2C46 | (2) 6L6 |
| (1) 5T4 | (1) 6SJ7 |
| (1) 5W4 | (1) 6SN7GT |
| (6) 6AC7 | (1) 2050 |

Total Tubes: (17)

(1) 1N28
Total Crystals: (1)

REFERENCE DATA AND LITERATURE

NAVAER 08-5S-78: Manual of Test Equipment for Airborne Electrical and Electronic Equipment.

TYPE CLASSIFICATION DESIGN COGNIZANCE BUAER PROCUREMENT COGNIZANCE STOCK NO. R.D.B. IDENT. NO. 5.5
--

EQUIPMENT SUPPLIED DATA

QUANTITY PER EQUIPT	NAME AND NOMENCLATURE	OVERALL DIMENSIONS (inches)	WEIGHT (lbs.)
1	Radio Interference Tester TS-277/AR including: Transit Case Antenna Assembly AS-325/AR Cord CX-337/U Cord CG-401/U	12 x 15-1/2 x 30-1/2 120 lg 168 lg	95
1	Set of Equipment Spares		

UNCLASSIFIED

4.5 TS-277/AR: 1

FIELD INTENSITY METER

TS-318/UP

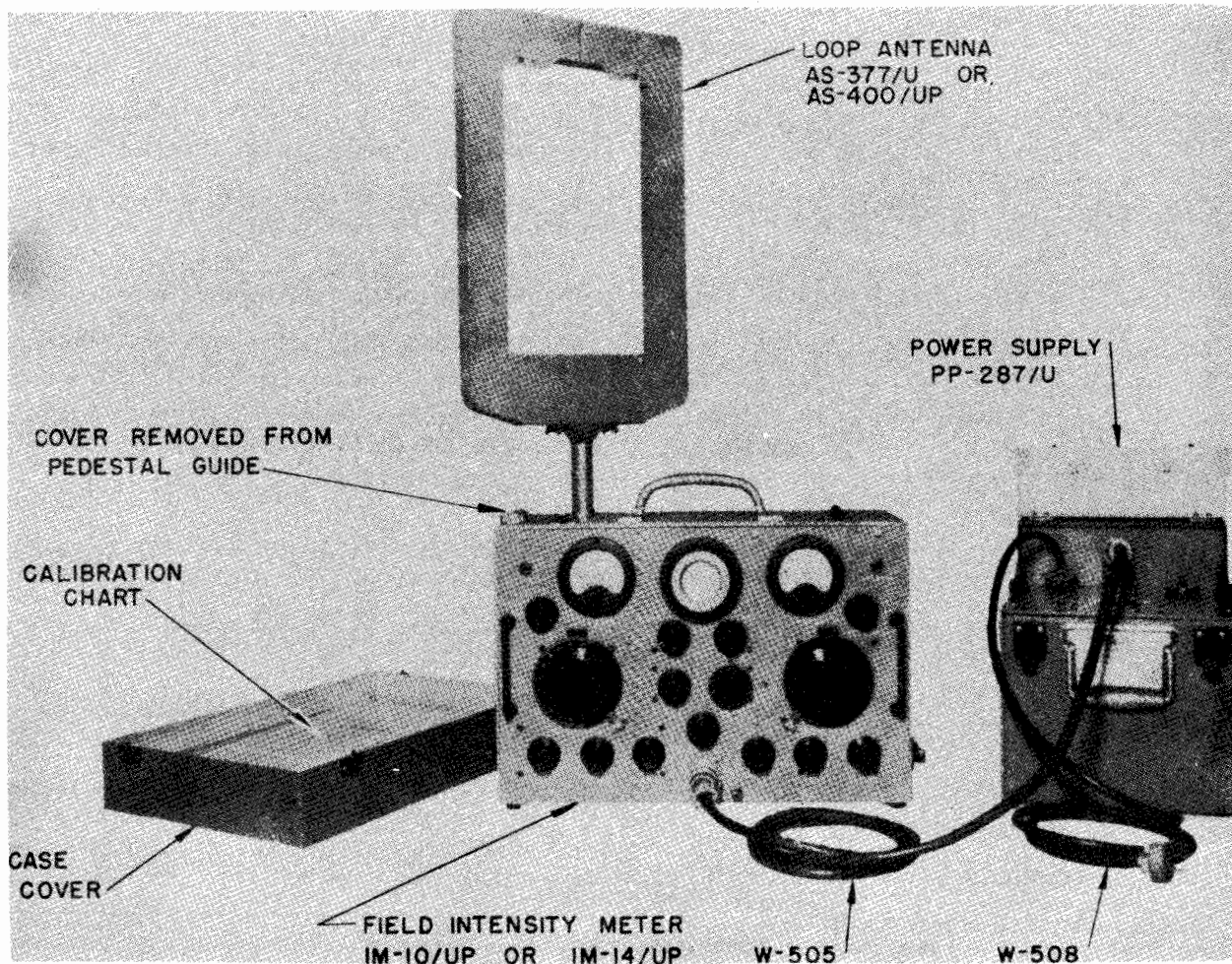

Field Intensity Meter TS-318/UP

FUNCTIONAL DESCRIPTION

The TS-318/UP is designed to measure the field intensity of the master and slave station pairs associated with Loran transmissions and of continuous wave radio frequency signals.

No field changes in effect at time of preparation (19 December 1956).

RELATION TO OTHER EQUIPMENT

Similar to TS-635/UP except for different frequency range.

Equipment Required but not Supplied: (1) Antenna vertical 10 to 60 ft high.

ELECTRICAL AND MECHANICAL CHARACTERISTICS

FREQUENCY RANGE: 1550 to 2500 kc, 1 band.

TYPE FREQUENCY CONTROL: Manual tuning.

TYPE SIGNALS MEASURED: Loran and CW.

PULSE RECURRENCE RATES MEASURED

S (slow): 49,300 to 50,000 usec.

L (low): 39,300 to 40,000 usec.

H (high): 29,300 to 30,000 usec.

FIELD INTENSITY RANGE

WITH LOOP ANTENNA: 50 uv per meter 59
50 v per meter.

WITH 60 FOOT VERTICAL ANTENNA: 1 uv per
meter min.

TYPE RECEIVER: Superheterodyne.

INTERMEDIATE FREQUENCY: 455 kc.

OUTPUT INDICATORS

Test-Field Intensity Measuring
TS-318/UP

FIELD INTENSITY METER

LORAN OR PULSE: 2 in CR tube.
CW: 0 to 1 ma DC meter
OPERATING POWER: 115 v, 60 cps, single ph
or 6 VDC battery.

(1) 6AL5 (3) 6AS6 (1) 6AQ6
(1) 6SA7 (1) OA3/VR-75 (1) 8016
(1) OD3/VR-150 (2) 9002 (3) 9003
Total Tubes: (18)

MANUFACTURER'S OR CONTRACTOR'S DATA

Washington Institute of Technology Inc,
Washington, D.C.
Contract NXsr 88850, dated 5 February
1945.
Contract NObsr 39362, dated 26 June
1947.
Approximate Cost: \$600.00 with equip-
ment spares.

REFERENCE DATA AND LITERATURE

NAVSHIPS 91089: Technical Manual for Field
Intensity Meters TS-318/UP and TS-635/UP.

TUBE AND/OR CRYSTAL COMPLEMENT

(1) 2AP1-A (1) 6X5GT/G (2) 6AK5

TYPE CLASSIFICATION
DESIGN COGNIZANCE BUSHIPS
PROCUREMENT COGNIZANCE
STOCK NO.
R.D.B. IDENT. NO.

SHIPPING DATA

NUMBER OF BOXES	CONTENTS AND IDENTIFICATION	VOLUME (Cu.Ft.)	OVERALL DIMENSIONS (inches)	WEIGHT PACKED (lbs.)
1	Field Intensity Meter IM-10/UP Antenna Assy AS-377/U Antenna Coupler CU-142/U Adapter, Signal Generator Output NT-62408 Video Output Cable Assy External Sync. Cable Assy Eye Shield Calibration Charts	5.2	18-1/4 X 18-1/4 X 26-5/8	104
2	Technical Manuals Power Supply PP-287/U Interunit Power Cable Assy NT-62407 Power Cable Assy External Battery Cable Assy (+) External Battery Cable Assy (-)	4.2	16-1/8 X 16-1/8 X 27-1/4	90
1	Battery Storage 6V-SBM-50AH	1.1	9-1/2 X 13 X 14-1/2	60
*	Equipment Spare Parts	2.9	14 X 14-3/4 X 24-1/4	80

* NUMBERED IN CONSECUTIVE ORDER BEGINNING WITH 1.

EQUIPMENT SUPPLIED DATA

QUANTITY PER EQUIP	NAME AND NOMENCLATURE	OVERALL DIMENSIONS (inches)	WEIGHT (lbs.)
1	Field Intensity Meter IM-10/UP	11-1/8 X 14-27/32 X 19-15/16	50.8
1	Antenna Assembly AS-377/U	1-3/16 X 12 X 28-1/4	5.5
1	Antenna Coupler CU-142/U	1-11/16 X 3-15/16 X 4-3/4	0.7

FIELD INTENSITY METER

EQUIPMENT SUPPLIED DATA

QUANTITY PER EQUIPT	NAME AND NOMENCLATURE	OVERALL DIMENSIONS (inches)	WEIGHT (lbs.)
1	Power Supply PP-287/U	11-1/16 X 11-7/8 X 20-9/16	37
1	Battery, Storage 6V-SBM-50AH	7-1/4 X 9-1/2 X 10	40
1	Adapter, Signal Generator Output NT-62408		
1	Assembly, Interunit Power Cable NT-62407	78 lg	
1	Power Cable Assy		
1	Video Output Cable Assy		
1	External Sync. Cable Assy		
1	Eye Shield		
1	External Battery Cable Assy (+)		
1	External Battery Cable Assy (-)		
1	Set Calibration Charts		
2	Technical Manuals		
1	Equipment Spare Parts	12 X 12 X 18-1/16	45

FIELD STRENGTH METER

TS-481/U

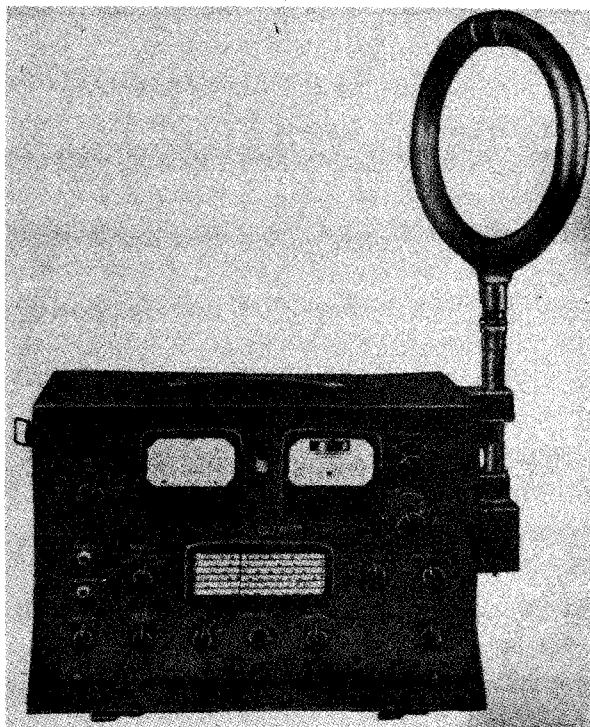

Field Strength Meter TS-481/U

RELATION TO OTHER EQUIPMENT

The TS-481/U is the Radio Corporation of America Model 308A.

ELECTRICAL AND MECHANICAL CHARACTERISTICS

FREQUENCY RANGE: 120 to 18000 kc.
INTENSITY RANGE: 20 uv to 10 v.
ACCURACY: $\pm 10\%$.
POWER REQUIREMENTS: Battery operated.

MANUFACTURER'S OR CONTRACTOR'S DATA

Radio Corporation of America, New York,
N. Y.

TUBE AND/OR CRYSTAL COMPLEMENT

No Electron Tubes.

REFERENCE DATA AND LITERATURE

TM11-487H: Directory of Signal Corps Equipment, Test Equipment.

FUNCTIONAL DESCRIPTION

The TS-481/U is a portable instrument used for field intensity measurements and consists of a superheterodyne receiver and a calibrating oscillator. It is battery operated and includes a loop antenna, headphones, and probe.

No field changes in effect at time of preparation (23 July 1957).

TYPE CLASSIFICATION
DESIGN COGNIZANCE TASSA
PROCUREMENT COGNIZANCE
STOCK NO.
R.D.B. IDENT. NO. 5.1

EQUIPMENT SUPPLIED DATA

QUANTITY PER EQUIPT	NAME AND NOMENCLATURE	OVERALL DIMENSIONS (inches)	WEIGHT (lbs.)
1	Field Strength Meter TS-481/U	13-1/4 X 13-1/2 X 20-1/4	48

21 May 1962

FIELD STRENGTH METER TS-509/UR

Cog Service: USN FSN:

Functional Class: 5.1

USA

USN

USAF

TYPE CLASS:

Std

MANUFACTURER'S NAME/CODE NUMBER: Harvey Wells Electronics Inc., (81635).

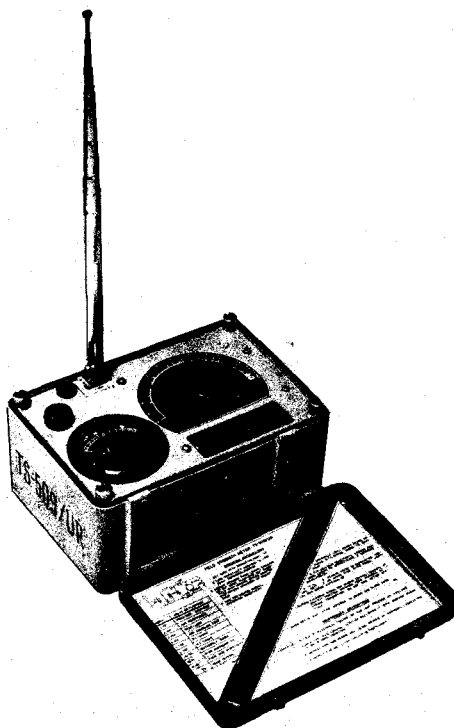

Field Strength Meter TS-509/UR

FUNCTIONAL DESCRIPTION:

Field Strength Meter TS-509/UR is a portable, self-contained unit used to provide an indication of the relative field strength and approximate frequency of radio frequency energy emitted by a transmitter.

No field changes in effect at time of preparation (28 February 1962).

TECHNICAL CHARACTERISTICS:

FREQUENCY RANGE: 100 to 400 mc.

TYPE OF RECEPTION: CW.

RF POWER RANGE: 40 W or less.

METER SCALE: 0 to 50.

DISTANCE RANGE: 0 to 75 ft.

ACCURACY: Porm 5%.

TS-509/UR FIELD STRENGTH METER

POWER REQUIREMENTS: None.

RELATION TO OTHER EQUIPMENT: None.

EQUIPMENT REQUIRED BUT NOT SUPPLIED: None.

MAJOR COMPONENTS

QTY	ITEM	STOCK NUMBERS	DIMENSIONS (INCHES)	WEIGHT (LBS)
1	Field Strength Meter TS-509/UR includes:		4-15/16 x 6 x 7-11/16	8
1	Rod Antenna		9/16 x 1-7/16 x 6-5/8 (collapsed)	0.3

REFERENCE DATA AND LITERATURE:

AN16-35TS509-3: Handbook of Maintenance Instructions for Field Strength Meter TS-509/UR.

TUBE, CRYSTAL AND/OR SEMI-CONDUCTOR DATA:

TUBES: None used.

CRYSTALS: None used.

SEMI-CONDUCTORS: (1) IN21B

SHIPPING DATA

PKGS	VOLUME (CU FT)	WEIGHT(LBS)
------	----------------	-------------

PROCUREMENT DATA

PROCURING SERVICE: USN

DESIGN COG: USN, BuWeps

SPEC &/OR: 16M21(Aer), MIL-F-18198

CONTRACTOR	LOCATION	CONTRACT OR ORDER NO.	APPROX. UNIT COST
Harvey Wells Electronics Inc. Dwg no. 9181008	South Bridge, Mass.	N0as-10404	
Jowil Electronics Inc. Telerad Mfg. Corp.	Philadelphia, Pa. New York, N.Y.	N383s-41247A N383s-4880A N383-17s-16624A	

4.5 TS-509/UR: 2

7 May 1962

Cog Service: USA FSN:

CEILOMETER TEST SET TS-555/GMQ-2
Functional Class: 5.6

USA

USN

USAF

TYPE CLASS:

Std

Used by

Std

MANUFACTURER'S NAME/CODE NUMBER: General Electric Co., (24446).

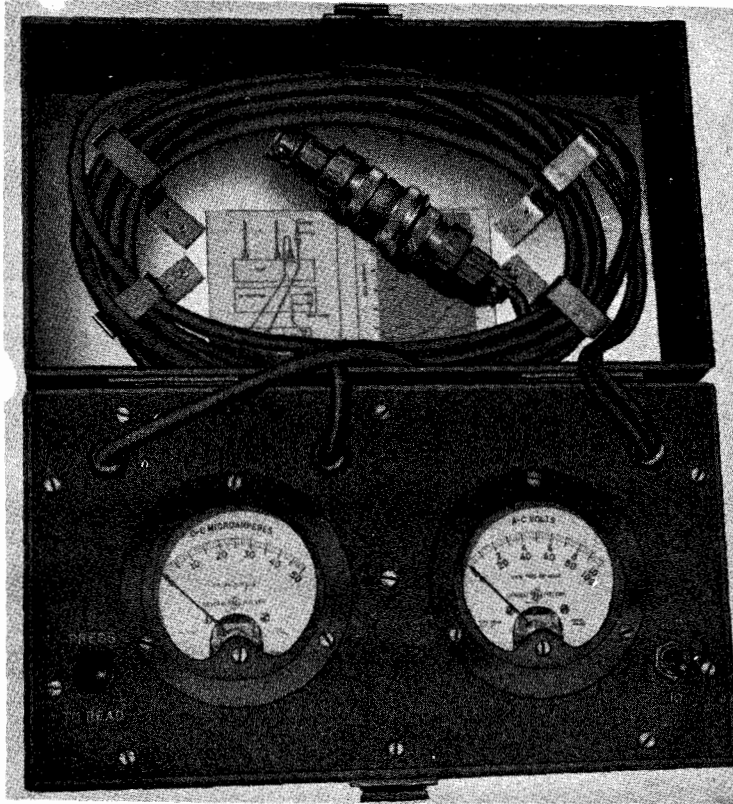

Ceilometer Test Set TS-555/GMQ-2

FUNCTIONAL DESCRIPTION:

Ceilometer Test Set TS-555/GMQ-2 is a portable instrument consisting of a microammeter for measuring phototube current and a double-range, rectifier-type, ac voltmeter for measuring thermal-noise and shot-noise output of the amplifier. This equipment is used to make a field check on detector performance without the presence of a signal directed by the projector and reflected from a cloud base.

No field changes in effect at time of preparation (24 October 1961).

TECHNICAL CHARACTERISTICS:

VOLTAGE RANGE: 0 to 10, 0 to 100 v ac.

CURRENT RANGE: 0 to 50 ua dc.

SENSITIVITY: 5,000 ohms/v.

ACCURACY: Form 2.5%.

TS-555/GMQ-2 CEILOMETER TEST SET

RELATION TO OTHER EQUIPMENT: None.

EQUIPMENT REQUIRED BUT NOT SUPPLIED: None.

MAJOR COMPONENTS

QTY	ITEM	STOCK NUMBERS	DIMENSIONS (INCHES)	WEIGHT (LBS)
1	Ceilometer Test Set TS-555/GMQ-2		6-3/8 x 6-5/8 x 11	8

REFERENCE DATA AND LITERATURE:

NAVSHIPS 900, 944(A): Technical Manual for Ceilometer Equipment AN/GMQ-2.

TM11-2419: Technical Manual for Ceilometer Equipment AN/GMQ-2.

TO 16-30GMQ2-5: Technical Manual for Ceilometer Equipment AN/GMQ-2.

TUBE, CRYSTAL AND/OR SEMI-CONDUCTOR DATA:

TUBES: None used.

CRYSTALS: None used.

SEMI-CONDUCTORS: None used.

SHIPPING DATA

PKGS	VOLUME (CU FT)	WEIGHT (LBS)
1	5	60

PROCUREMENT DATA

PROCURING SERVICE: USA

DESIGN COG: USA, Sig C

SPEC &/OR DWG:

CONTRACTOR	LOCATION	CONTRACT OR ORDER NO.	APPROX. UNIT COST
General Electric Co.	Schenectady, N. Y.	NXsr-69262, 5 August 1944 NObsr-42084, 28 January 1948	\$274.00

Test-Field Intensity Measuring
FIELD STRENGTH METER TS-579/U

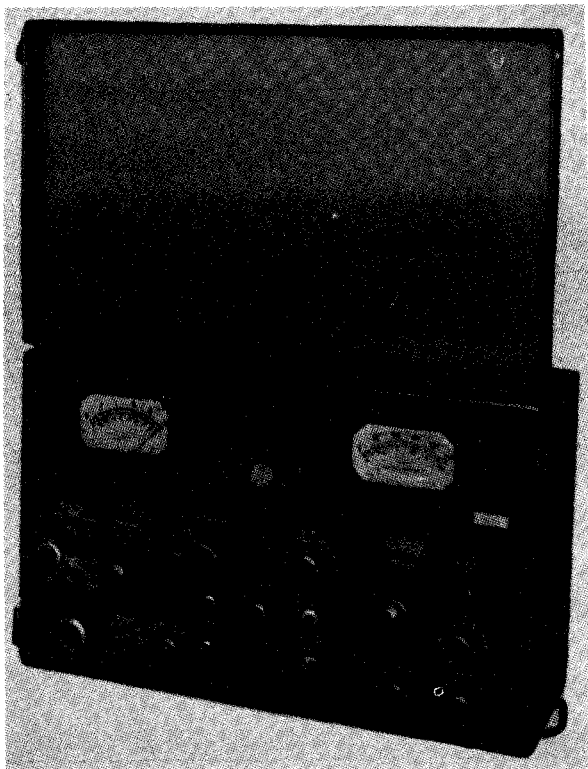

Field Strength Meter TS-579/U

FUNCTIONAL DESCRIPTION

The TS-579/U is a portable h-f field intensity meter. It is used to measure field intensities of FM and AM stations operating in the frequency range of 18 to 125 mc and to check antenna efficiency, directivity, and service range. When used with a recording meter, a permanent, continuous record may be made of variations in signal inten-

sity.

No field changes in effect at time of preparation (4 February 1957).

RELATION TO OTHER EQUIPMENT

Similar to RCA Model 301-B.

ELECTRICAL AND MECHANICAL CHARACTERISTICS

FREQUENCY RANGE: 18 to 125 mc.

INTENSITY RANGE: 10 to 2,500,000 uv per meter.

OUTPUT: 20 or 40 db.

POWER: Battery operated.

TUBE AND/OR CRYSTAL COMPLEMENT

No Electron Tubes.

REFERENCE DATA AND LITERATURE

TM11-487H: Technical Manual for Test Equipment.

TYPE CLASSIFICATION
DESIGN COGNIZANCE TASSA
PROCUREMENT COGNIZANCE
STOCK NO.
R.D.B. IDENT. NO.

EQUIPMENT SUPPLIED DATA

QUANTITY PER EQUIP	NAME AND NOMENCLATURE	OVERALL DIMENSIONS (inches)	WEIGHT (lbs.)
1	Field Strength Meter TS-579/U	9-1/4 x 13 x 19	38-

UNCLASSIFIED
April 1958

Test-field Intensity Measuring

NOISE-FIELD INTENSITY METERS

TS-587/U, -587A/U

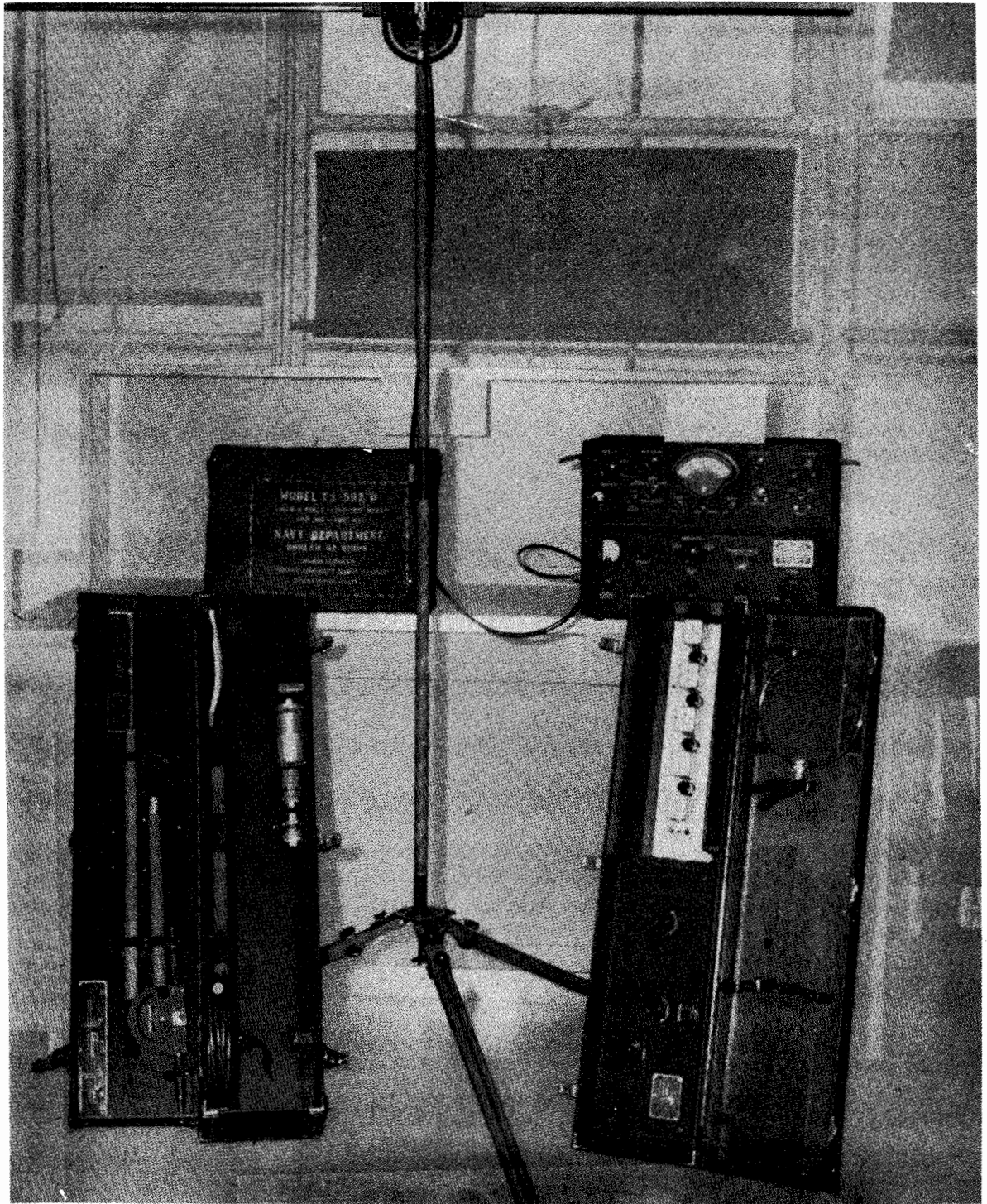

Noise-Field Intensity Meters TS-587/U, TS-587A/U

UNCLASSIFIED

4.5 TS-587/U: 1

Test-Field Intensity Measuring

TS-587/U,-587A/U NOISE-FIELD INTENSITY METERS

FUNCTIONAL DESCRIPTION

The Noise-Field Intensity Meter TS-587/U or TS-587A/U is a high sensitivity HF and VHF superheterodyne radio receiver covering the frequency range of 15 to 400 mc. With a probe it is used as a selective radio frequency voltmeter. It also contains internal means for calibrating its vacuum tube voltmeter section, thus permitting direct readings in indicated microvolts that are readily converted to true microvolts or microvolts-per-meter. Microvolt-per-meter readings can be obtained when the dipole antennas furnished with the equipment are used. The various probes can be used for readings of the RF level of the signal or interference at the probe location.

No field changes in effect at time of preparation (9 May 1958).

RELATION TO OTHER EQUIPMENT

The Noise-Field Intensity Meter TS-587A/U is a modified commercial Model NMA-3A to make it equivalent to Noise-Field Intensity Meter TS-587/U. Noise-Field Intensity Meter TS-587A/U is similar to and interchangeable with Noise-Field Intensity Meter TS-587/U. Modification Kit MX-910/U enables Noise-Field Intensity Meter TS-587/U Series to operate from batteries and also supplies an amplifier to drive an external recording meter. It supplies other accessories as well. The Navy Model OCV becomes a Noise-Field Intensity Meter TS-587/U when Navy Field Change No. 2-OCV is applied to it.

ELECTRICAL AND MECHANICAL CHARACTERISTICS

POWER SUPPLY: 105 to 125 v ac, 60 to 400 cps, 99 W, or 12 v dc at 17 amp (with Modification Kit MX-910).

FREQUENCY RANGE: 15 to 31 mc, 12 mc if; 20 to 64 mc, 12 mc if; 60 to 125 mc, 12 mc if; 100 to 400 mc, 30 mc if.

SENSITIVITY

AS SELECTIVE RF VOLTMETER: 5 uv, 100 to 400 mc; 2 uv, 15 to 100 mc.

WITH 6 MW AUDIO INTO RATED LOAD, RF MOD 30% AT 1000 CPS: 5 uv, 100 to 400 mc; 2 uv, 15 to 100 mc.

AS FIELD INTENSITY METER: 20 uv per meter, 100 to 400 mc; 5 uv per meter, 15 to 100 mc.

SELECTIVITY

BANDWIDTH, 0 to -6 DB: 210 kc, 100 to 400 mc rf; 150 kc, 15 to 100 mc rf.

IMAGINE FREQUENCY RESPONSE: -60 db.

RECEIVER OUTPUT: 200 mw into rated load.

RECEIVER FIDELITY: ± 3 db, 300 to 3000 cps.

IMPEDANCES

INPUT RF: 95 ohms, balanced.

OUTPUT AF: 300 to 4000 ohms, for headset.

MANUFACTURER'S OR CONTRACTOR'S DATA

Stoddard Aircraft Radio Co, Hollywood, California.

Contract NObsr-30088, dated 15 June 1946.

Contract NObsr-30140, dated 21 June 1940.

Contract NObsr-30200, dated 26 June 1946

Contract NObsr-39272, dated 27 June 1947.

TUBE AND/OR CRYSTAL COMPLEMENT

TS-587/U,-587A/U

(1) OD3W	(4) 5749/6BA6W
(2) 6J4WA	(4) 6SG7Y
(1) 5Y3WGTB	(2) 6AQ6
(1) 6J5GT	(1) 6SJ7
(2) 5654/6AK5W	(2) 6C4WA
(1) 6J6WA	(2) 6V6Y
(2) 5726/6AL5W	(1) 6H6
(1) 6L6WGB	(1) 9002

Total Tubes: (28)

UNCLASSIFIED

April 1958

Test-Field Intensity Measuring

NOISE-FIELD INTENSITY METERS

TS-587/U,-587A/U

No Crystals Used.

REFERENCE DATA AND LITERATURE

NAVSHIPS 900990: Technical Manual for Noise Intensity Meter TS-587/U, and TS-587A/U.

TYPE CLASSIFICATION	Standard
DESIGN COGNIZANCE	BUSHIPS
PROCUREMENT COGNIZANCE	
STOCK NO.	
R.D.B. IDENT. NO.	5.6

SHIPPING DATA

NUMBER OF BOXES	CONTENTS AND IDENTIFICATION	VOLUME (Cu.Ft.)	OVERALL DIMENSIONS (inches)	WEIGHT PACKED (lbs.)
1	Noise-Field Intensity Meter TS-587/U	35.3	36 X 36 X 47	330

EQUIPMENT SUPPLIED DATA

QUANTITY PER EQUIPT	NAME AND NOMENCLATURE	OVERALL DIMENSIONS (inches)	WEIGHT (lbs.)
1	Noise-Field Intensity Meter TS-587/U	15-3/16 X 21-1/2 X 14-9/16	64
1	Canvas Cover for above		2
1	Equipment Case CY-606/U containing:	15 X 40 X 9	with content, 53; Empty, 23
	1 Radio Frequency Head RF-36/U	6-1/2 X 17-1/2 X 14	
	1 Intermediate Frequency Amplifier AM-194/U	4-1/2 X 13-1/2 X 5	
	1 Dipole Antenna AS-385/U	60 lg	
	2 Dipole Mast Sections for AS-385/U	33 lg	
	1 Loop Probe MX-822/U	8-3/8 dia	
	1 Measuring Tape NT-10671	2 X 1-3/4 X 3/4	
	2 Instruction Books NAVSHIPS 900,990		
1	Accessory Case CY-607/U containing:	15 X 40 X 9	with contents, 40; Empty, 25
	1 Dipole Antenna NT-66151-A	44 lg	
	2 Dipole Mast Sections for NT-66151-A		
	1 Loop Probe MX-821/U	5-1/2 lg X 1-17/32 dia	
	1 Line Probe NT-491087	5-3/8 lg X 2-1/4 dia	
	1 Antenna Tripod NT-10545	37-1/2 lg X 3-13/16 dia	
	1 Matching Impedance NT-471228	2-5/8 lg X 1-23/32 dia	
	1 Input Cable CG-444/U	20 ft lg	
	1 Input Cable CG-444/U	72 lg	
	1 Power Cable		

UNCLASSIFIED

4.5 TS-587/U: 3

NOISE-FIELD INTENSITY METER

TS-587B/U

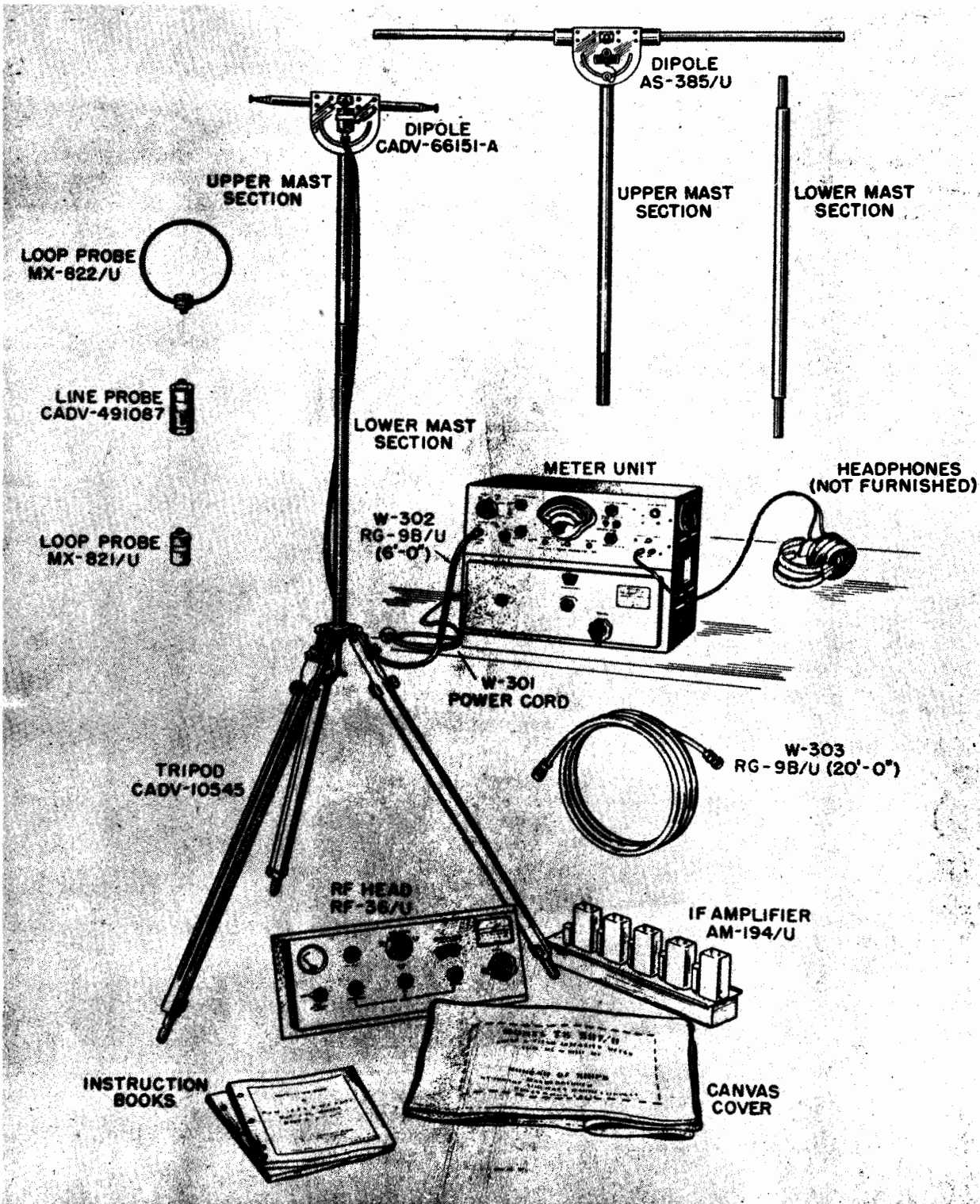

Noise-Field Intensity Meter TS-587B/U

October 1957

Test-Field Intensity Measuring

TS-587B/U**NOISE-FIELD INTENSITY METER****FUNCTIONAL DESCRIPTION**

The TS-587B/U is a high-sensitivity HF and VHF radio receiver used to locate and measure RF interference (noise) and to make field strength measurements in the 15 to 400 mc portion of the radio spectrum. It is basically a selective two terminal voltmeter with sufficient sensitivity to measure RF interference or the intensity of radiated or conducted RF signals. The instrument is provided with dipole antennas and probes for noise or signal pick-up. Proper use of these pick-up devices will enable the operator to locate the source of the signal or interference by successive measurements. The meter readings can be converted to micro-volt-per-meter (uv/m) by the use of correction curves.

No field changes in effect at time of preparation (7 February 1957).

RELATION TO OTHER EQUIPMENT

Similar to the TS-587/U except that this equipment includes 50 cps RF output. Improved calibration procedures and accuracy.

Equipment Required but not Supplied: 2 Set of 600 or 8000 ohm impedance head phones.

ELECTRICAL AND MECHANICAL CHARACTERISTICS

FREQUENCY RANGE: 15 to 400 mc in 4 bands.

BAND DATA

HF: 100 to 400 mc.

LF: 60 to 125 mc, 29 to 64 mc and 15 to 31 mc.

RECEIVER TYPE: Superheterodyne.

INTERMEDIATE FREQUENCY

HF: 30 mc.

LF: 12 mc.

SENSITIVITY: 20 uv/m max.

SELECTIVITY: 210 kc HF; 150 kc LF at 6 db down.

RECEIVER OUTPUT: 200 mw max.

RECEIVER FIDELITY: Response is flat to within ± 3 db of the 1000 cycle value from 300 to 3000 cycles into a matching resistive load.

TYPE OF RECEPTION: Carrier, modulated carrier, pulse or radio interference (noise).

INPUT IMPEDANCE: 50 ohms to ground,
OUTPUT IMPEDANCE: 300 or 4000 ohms.
POWER SOURCE REQUIRED: 105 to 125 v, 60 cps,
single ph, 112 W.

MANUFACTURER'S OR CONTRACTOR'S DATA

Stoddard Aircraft Radio Co., Hollywood, Calif.

Contract Nobsr-30088, dated 12 June 1946.

Contract Nobsr-30140, dated 21 June 1946.

Contract Nobsr-30200, dated 26 June 1946.

American Electronics Laboratories, Inc., Philadelphia, Pa.

Contract Nobsr-39272, dated 27 June 1947.

Contract Nobsr-71131, dated 13 December 1955.

TUBE AND/OR CRYSTAL COMPLEMENT

(1) OD3/VR-150	(1) 5R4
(2) 6AK5	(2) 6AQ6
(4) 6BA6	(2) 6C4
(1) 6H6	(2) 6J4
(1) 6SN7	(2) 6J6
(1) 6L6GA	(4) 6SG7
(1) 6SJ7	(2) 6V6 or
(1) 9002	6V6GT/G
(1) 5722	

Total Tubes: (30)

REFERENCE DATA AND LITERATURE

Technical Manual for Noise-Field Intensity Meter TS-587/U and TS-587B/U.

TYPE CLASSIFICATION	
DESIGN COGNIZANCE	BUSHIPS
PROCUREMENT COGNIZANCE	
STOCK NO.	
R.D.B. IDENT. NO.	

UNCLASSIFIED

October 1957

Test-Field Intensity Measuring

NOISE-FIELD INTENSITY METER

TS-587B/U

SHIPPING DATA

NUMBER OF BOXES	CONTENTS AND IDENTIFICATION	VOLUME (Cu.Ft.)	OVERALL DIMENSIONS (inches)	WEIGHT PACKED (lbs.)
1	Noise-Field Intensity Meter TS-587B/U	35.3	36 X 36 X 47	

EQUIPMENT SUPPLIED DATA

QUANTITY PER EQUIPT	NAME AND NOMENCLATURE	OVERALL DIMENSIONS (inches)	WEIGHT (lbs.)
1	Equipment Case CY-606/U CONTAINING:	9 X 15 X 40	empty full 23 53
1	Radio Frequency Head (15-125 MC) RF-36/U		
1	I. F. Amplifier (12 MC) AM-194/U		
1	Dipole Antenna AS-385/U		
1	Dipole Mast Section A-304		
1	Dipole Mast Section A-305		
1	Loop Probe MX-822/U		
1	Measuring Tape CADV-10671		
2	Technical Manuals		
1	Accessory Case CY-607/U CONTAINING:	9 X 15 X 40	empty full 25 40
1	Dipole Antenna E-312		
1	Dipole Mast Section A-302		
1	Dipole Mast Section A-301		
1	Loop Probe MX-821/U		
1	Line Probe E-314		
1	Antenna Tripod E-301		
1	Balancing Transformer		
1	Input Cable W-302		
1	Input Cable W-303		
1	Power Cord		

UNCLASSIFIED

June 1957

FIELD INTENSITY METER

TS-635/UP

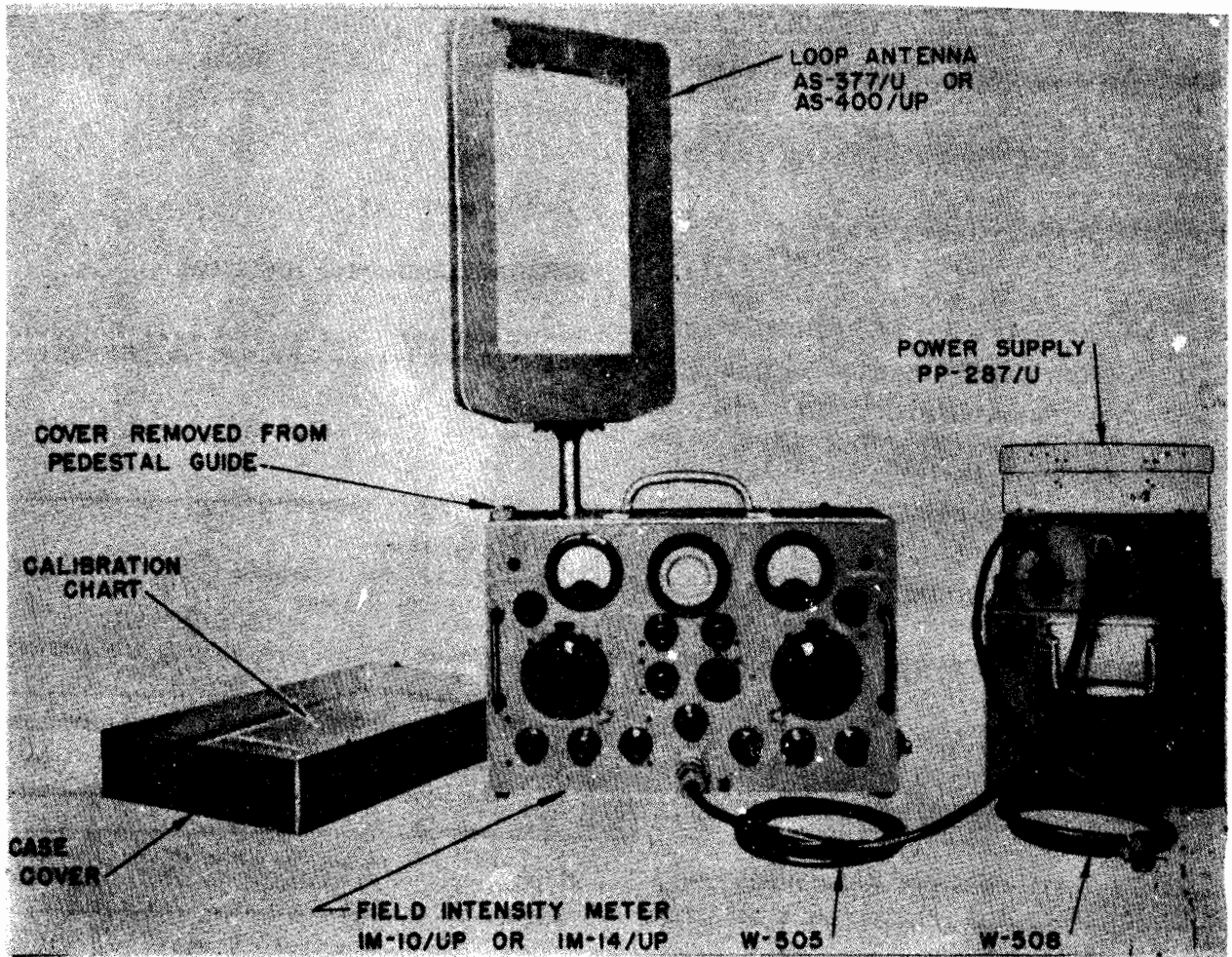

Field Intensity Meter TS-635/UP

FUNCTIONAL DESCRIPTION

The TS-635/UP is a portable instrument consisting of a field intensity meter, a power supply unit and accessories. It is used for making field intensity measurements in the 110 kc to 200 kc range. The unit is contained in a grey wrinkle finished aluminum carrying case with a carrying handle at the top. All accessories and cables are stowed in the carrying case cover.

No field changes in effect at time of preparation (9 October 1956).

RELATION TO OTHER EQUIPMENT

Similar to TS-318/UP except for frequency range coverage.

Equipment Required but not Supplied: (1) Vertical Antenna, 10 to 60 ft high.

ELECTRICAL AND MECHANICAL CHARACTERISTICS

FREQUENCY RANGE: 110 kc to 220 kc in one band.

FREQUENCY CONTROL: Manual tuning.

June 1957

Test-Field Intensity Measuring

TS-635/UP

FIELD INTENSITY METER

TYPE OF SIGNALS MEASURED: Loran and continuous wave.

PULSE RECURRENT RATES MEASURED: 49,300 to 50,000 usec, 39,300 to 40,000 usec, 29,300 to 30,000 usec.

FIELD INTENSITY RANGE: 50 uv/m to 15 v/m
W/loop antenna, 1 uv/m W/60 ft vertical antenna.

RECEIVER TYPE: Superheterodyne.

INTERMEDIATE FREQUENCY: 455 kc.

OUTPUT INDICATORS: 2 in. cathode ray tube for Loran or pulse, 0 to 1 ma dc meter for CW.

POWER SOURCE: 115 v 60 cps, single ph or 6 v DC.

(1) 6SA7
(1) OD3/VR-150
(2) 9002

(1) OA3/VR-75
(1) 8016
(3) 9003

Total Tubes: (18)

(1) IN34

Total Crystals: (1)

REFERENCE DATA AND LITERATURE

NAVSHIPS 91089: Technical Manual for Field Intensity Meters TS-318/UP and TS-635/UP.

MANUFACTURER'S OR CONTRACTOR'S DATA

Washington Institute of Technology,
Washington, DC

*Contract NXsr 88850, dated 5 February 1945.

TUBE AND/OR CRYSTAL COMPLEMENT

(1) 2AP1-A
(2) 6AK5
(3) 6AS6

(1) 6X5GT/G
(1) 6AL5
(1) 6AQ6

TYPE CLASSIFICATION	
DESIGN COGNIZANCE	BUSHIPS
PROCUREMENT COGNIZANCE	
STOCK NO.	
R.D.B. IDENT. NO.	

SHIPPING DATA

NUMBER OF BOXES	CONTENTS AND IDENTIFICATION	VOLUME (Cu.Ft.)	OVERALL DIMENSIONS (inches)	WEIGHT PACKED (lbs.)
1	Field Intensity Meter IM-14/UP Antenna Assembly AS400/UP Antenna Coupler CU-155/U Adapter, Signal Generator Output CWI-62408 Video Output Cable Assembly Ext Syne Cable Assembly Eye Shield Calibration Charts	5.2	18-1/4 X 18-1/4 X 26-5/8	104
1	Instruction Books NAVSHIPS 91089 Power Supply (less batteries) PP-287/U Interunit Power Cable Assembly NT-62407(6'6") Power Cable Assembly External Battery Cable Assembly(+) External Battery Cable Assembly(-)	4.2	16-1/8 X 16-1/8 X 27-1/4	90
1	Storage Battery 6V-SBM-50AH	1.1	9-1/2 X 13 X 14-1/2	60
1	Spare Parts	2.9	14 X 14-3/4 X 24-1/4	80

UNCLASSIFIED

June 1957

Test-Field Intensity Measuring

FIELD INTENSITY METER

TS-635/UP

EQUIPMENT SUPPLIED DATA

QUANTITY PER EQUIPT	NAME AND NOMENCLATURE	OVERALL DIMENSIONS (inches)	WEIGHT (lbs.)
1	Power Supply (less batteries) PP-287/U	11-1/16 X 11-7/8 X 20-9/16	37
1	Field Intensity Meter IM-14/UP	11-1/8 X 14-27/32 X 19-15/16	50.9
1	Antenna Assembly AS-400/UP	1-3/16 X 12 X 28-1/4	5.5
1	Antenna Coupler CU-155/U	1-11/16 X 3-15/16 X 4-3/4	0.7
1	Storage Battery 6Y-SBM-50AH	7-1/4 X 9-1/2 X 10	40.
1	Signal Generator Output Adapter NT-62408		
6	Cable Assemblies		
1	Set of Calibration Charts		
2	Technical Manuals NAVSHIPS 91089		
1	Set of Equipment Spares	12 X 12 X 18-1/16	45

UNCLASSIFIED

4.5 TS-635/UP: 3

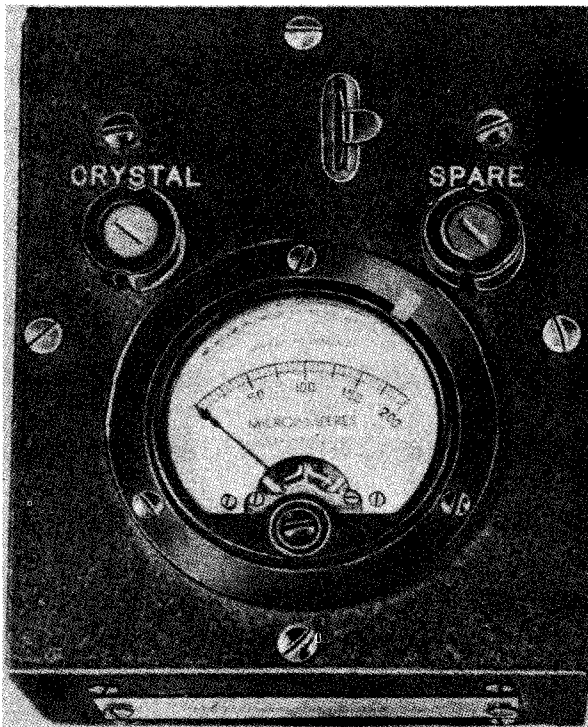
CRYSTAL INDICATOR**TS-94/AX**

Crystal Indicator TS-94/AX

No field changes in effect at time of preparation (10 July 1957).

ELECTRICAL AND MECHANICAL CHARACTERISTICS

FREQUENCY RANGE: 50 to 500 mc.
METER RANGE: 0 to 200 ua DC.

MANUFACTURER'S OR CONTRACTOR'S DATA

Radio Corporation of America, Camden,
N. J.

TUBE AND/OR CRYSTAL COMPLEMENT

(2) 1N21

Total Crystals: (2)

REFERENCE DATA AND LITERATURE

NAVAER 08-5S-78: Manual of Test Equipment for Airborne Electrical and Electronic Equipment.

TYPE CLASSIFICATION	
DESIGN COGNIZANCE	BUAER
PROCUREMENT COGNIZANCE	
STOCK NO.	
R.D.B. IDENT. NO.	

FUNCTIONAL DESCRIPTION

The TS-94/AX is a portable crystal resonance indicator designed for indicating relative strength of a radio frequency field of frequencies up to 500 megacycles. It has a retractable steel tape that provides control of the amplitude. It is used to service special radio control equipment.

EQUIPMENT SUPPLIED DATA

QUANTITY PER EQUIPT	NAME AND NOMENCLATURE	OVERALL DIMENSIONS (inches)	WEIGHT (lbs.)
1	Crystal Indicator TS-94/AX	3 X 4 X 5	3

April 1958

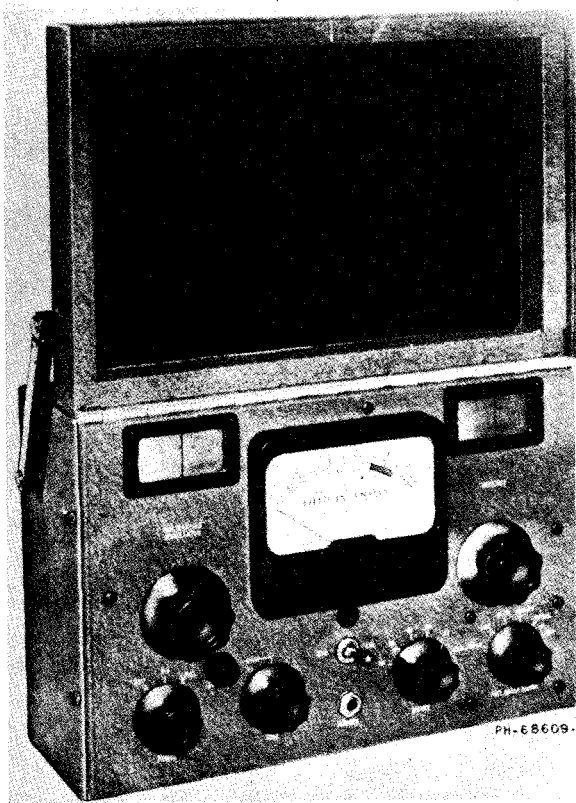
FIELD INTENSITY METER**WX-2D (RCA)***Field Intensity Meter WX-2D***FUNCTIONAL DESCRIPTION**

The type WX-2D Field Intensity Meter is a compact, light weight portable instrument for the measurement of a wide range of radio signal intensities in the broadcast band of 540 to 1600 kc. Its range of sensitivity, from 10 microvolts per meter to 10 volts per meter, makes it equally effective for interference studies at low signal strengths and for close in measurements on high-power directional arrays. Provisions are made for using a recorder or high impedance headphones. This equipment can also be used with an external power supply.

No field changes in effect at time of preparation (19 March 1958).

RELATION TO OTHER EQUIPMENT

Equipment Required but not Supplied: (5) 1.5 v Batteries, RCA type VS-001, (2) 67.5 v Batteries, RCA type VS-016.

ELECTRICAL AND MECHANICAL CHARACTERISTICS

FREQUENCY RANGE: 540 to 1600 kc.

FIELD INTENSITY RANGE: 10 uv to 10 v per meter.

ACCURACY OF ATTENUATORS: 2%.

OUTPUT INDICATOR: Panel Meter direct reading with logarithmic scale graduated 1 to 10 and having no zero mark.

POWER REQUIREMENTS: 1.5 v and 67 1/2 v DC.

ANTENNA: Shielded, Unbalanced Loop.

MANUFACTURER'S OR CONTRACTOR'S DATA

RCA Victor Division Radio Corporation of America, Camden, N. J.
Contract NObsr 64616.

TUBE AND/OR CRYSTAL COMPLEMENT

(4) 1T4

(2) 1R5

Total Tubes: (6)

(2) 1N34A

Total Crystals: (2)

NAVSHIPS 92541: Instruction Book for Field Intensity Meter RCA Type WX-2D (MI-30002-D).

TYPE CLASSIFICATION
DESIGN COGNIZANCE
PROCUREMENT COGNIZANCE
STOCK NO.
R.D.B. IDENT. NO.

EQUIPMENT SUPPLIED DATA

QUANTITY PER EQUIP	NAME AND NOMENCLATURE	OVERALL DIMENSIONS (inches)	WEIGHT (lbs.)
1	Field Intensity Meter, type WX-2D *Including Batteries.	5-3/4 X 9 X 13	12-1/2*

April 1958

RADIO NOISE METER CONVERTER 104 (DYNAMICS ELECTRONICS)

Test-Field Intensity Measuring

No field changes in effect at time of preparation (17 March 1958).

RELATION TO OTHER EQUIPMENT

Equipment Required but not Supplied: (1) Communication Receiver (15 kc to 1000 mc), (1) RF Signal Generator with Calibrated Level Meter (15 kc to 1000 mc), (1) Earphones, (1) Coaxial Connector Cable, (1) DC Voltmeter or VTVM.

ELECTRICAL AND MECHANICAL CHARACTERISTICS

OUTPUT METER: 0 to 100 uv (linearly calibrated).

FREQUENCY RANGE: 15 kc to 1000 mc.

SENSITIVITY: 7 v at input to VTVM for full scale deflection (adjustable).

IMPULSE GENERATOR

PULSE WIDTH: 0.0005 usec.

FREQUENCY SPECTRUM: 0.01 mc to 1000 mc, flat within $\pm 1/2$ db.

OUTPUT IMPEDANCE: 50 ohms.

OUTPUT LEVEL: 0 to 100,000 uv/mc in 1 db steps.

REPETITION RATE: 60 cps.

ROD ANTENNA INPUT IMPEDANCE: 10 uuf.

POWER SOURCE REQUIRED: 105 to 125 v, 50 to 60 cps, 1 ph, 110 W.

MANUFACTURER'S OR CONTRACTOR'S DATA

Dynamic Electronics-New York Inc., Glendale L. I., N. Y.

TUBE AND/OR CRYSTAL COMPLEMENT

(1) 5687	(2) 6J6
(1) 6AL5	(2) 12AU7
(1) 5R4GY	(3) 0A2

Total Tubes: (11) (1) 5718

(1) 1N92 (1) 1N54A

Total Crystals: (2)

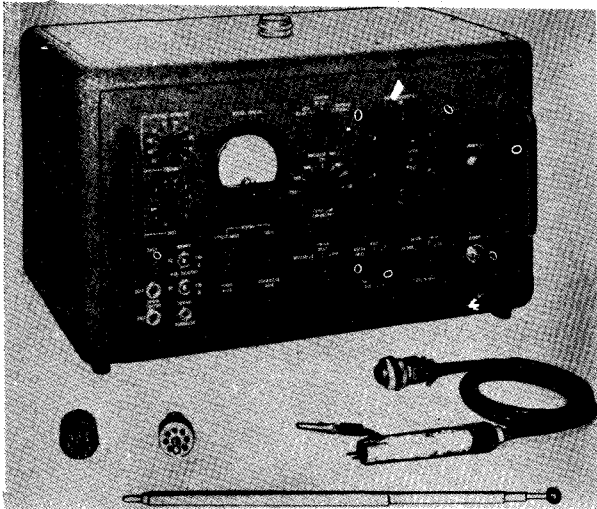

Radio Noise Meter Converter 104

FUNCTIONAL DESCRIPTION

The Dynamics Model 104 enables noise measurement to be made, utilizing existing communication type receivers as part of the noise measuring equipment. Both conducted and radiated noise may be measured. The frequency spectrum of measurable noise is between 15 kc to 1000 mc. The frequency range of the associated communications receiver determines the frequency of noise that may be measured with that receiver. Any AM or FM receiver (without a limiter) operating within the range of 15 kc to 1000 mc may be used.

Average quasi-peak, and peak reading of interference can be made with this equipment. These readings make it possible to identify, in some cases, the character of the noise measured, whether it is impulse noise or random noise.

An impulse calibrator is built in, use of the calibrator permits measurement of impulse noise by direct comparison.

The effective height of the Service Antenna used with the communications receiver, can also be determined, hence the equipment can be used as a field strength meter.

In general the Converter can make the same type of measurements that are made by many commercial types of noise-meters.

Test-Field Intensity Measuring

104 RADIO NOISE METER CONVERTER (DYNAMICS ELECTRONICS)

April 1958

REFERENCE DATA AND LITERATURE

NAVSHIPS 92611: Handbook of Operating Instructions for Radio Noise Meter Converter Dynamic Model 104.

TYPE CLASSIFICATION DESIGN COGNIZANCE PROCUREMENT COGNIZANCE STOCK NO. R.D.B. IDENT. NO.
--

EQUIPMENT SUPPLIED DATA

QUANTITY PER EQUIPT	NAME AND NOMENCLATURE	OVERALL DIMENSIONS (inches)	WEIGHT (lbs.)
1	Radio Noise Meter Converter—Main Unit	12 X 12-3/8 X 20-5/8	
1	Standard Rod Antenna		
1	Probe w/cable		
2	Adapters for IF Probe Unit		

April 1958

SOUND ANALYZER

Test-Field Intensity Measuring

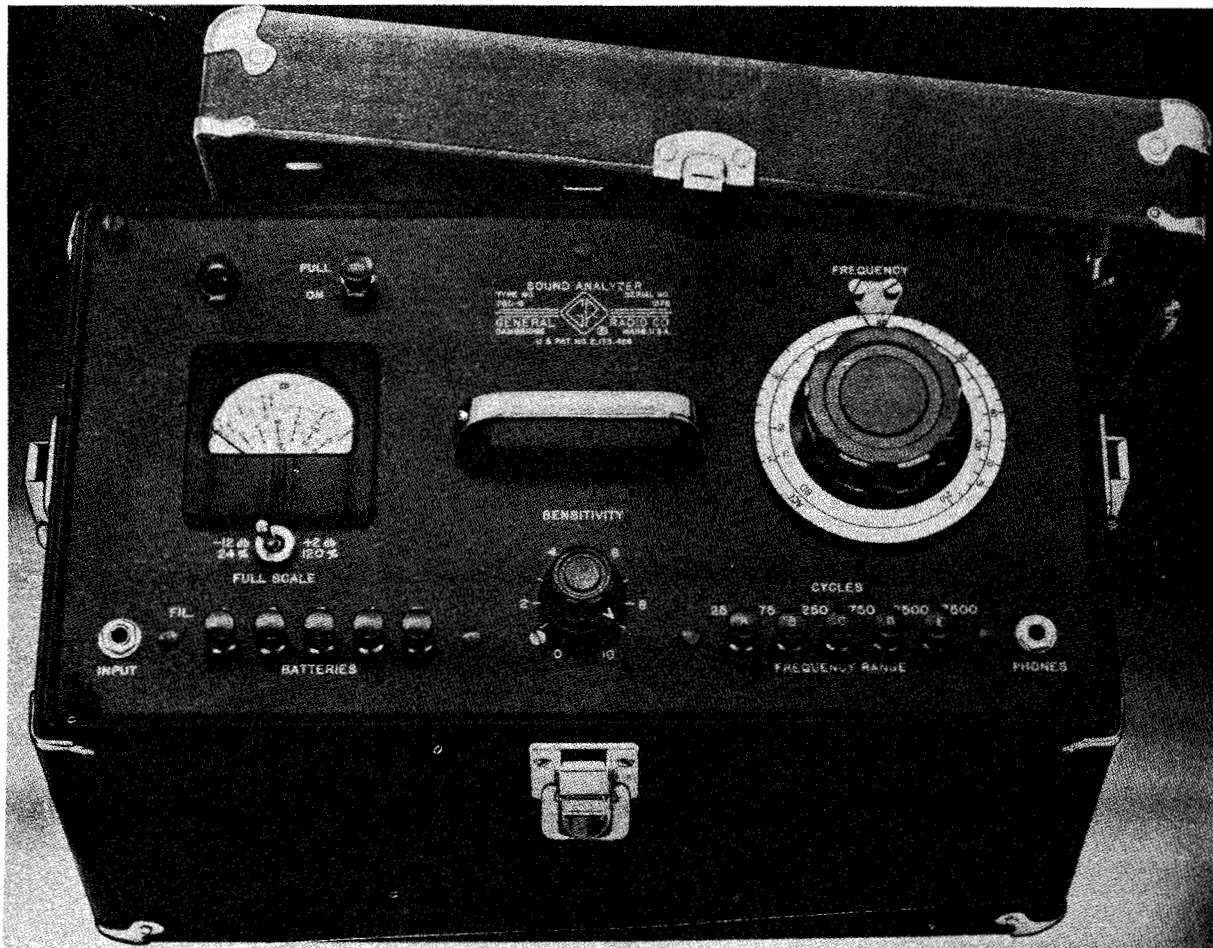
**760-B
(GENERAL RADIO CO)***Sound Analyzer 760-B***FUNCTIONAL DESCRIPTION**

The 760-B (General Radio Co) is intended primarily for use with the type 1551-A or type 759-B Sound Level Meter to separate complex sounds and noises into their various frequency components. It can also be used as a general-purpose laboratory harmonic analyzer and as a frequency selective bridge detector for audio frequencies. The band width of the analyzer is a constant percentage of the frequency to which the analyzer is tuned.

No field changes in effect at time of preparation (13 March 1958).

ELECTRICAL AND MECHANICAL CHARACTERISTICS

FREQUENCY RANGE: 25 to 7500 cps direct reading.

DIAL RANGES: 25 to 75, 75 to 250, 250 to 750, 750 to 2500, and 2500 to 7500 cps.

FREQUENCY CALIBRATION ACCURACY: $\pm 1.5\%$ of the frequency to which the dial is set or ± 1.5 cps whichever is larger.

FREQUENCY RESPONSE: Flat within ± 2 db over the entire range. At points where two ranges overlap, the sensitivity is the same on either range within ± 1 db.

BANDWIDTH: Relative attenuation is 3 db at 1% off the peak to which the analyzer is tuned.

INPUT VOLTAGE RANGE: 1 mv to 10 v for usable indications. The meter scale is calibrated for reading directly component tones down to 1% of the sound pressure (or voltage) of the fundamental or loudest component. Hence, the input voltage at the loudest component or fundamental should be 0.1 v or higher.

Test-Field Intensity Measuring

**760-B
(GENERAL RADIO CO)****SOUND ANALYZER**

April 1958

INPUT IMPEDANCE: 20,000 to 30,000 ohms depending upon the sensitivity control.

METER: The indicating meter is calibrated in two ranges. For convenience in use, the meter scale is calibrated with the 0 located 2 db below full scale on the meter, so that actual meter scales are +2 to -30 db and -12 to -40 db. Auxiliary percentage ranges of 0 to 120% and 0 to 24% are provided.

OUTPUT: A jack is provided on the panel for plugging in a pair of head telephones, in order to listen to the actual component of the sound to which the instrument is tuned.

POWER SOURCE REQUIRED: 6 v and 135 v DC.

TUBE AND/OR CRYSTAL COMPLEMENT

(3) 114 (1) 1U4
Total Tubes: (4)

No Crystals Used.

REFERENCE DATA AND LITERATURE

NAVSHIPS 92116, Technical Manual for Type 760-B Sound Analyzer.

MANUFACTURER'S OR CONTRACTOR'S DATA

General Radio Co, Cambridge, Mass.
Contract: NObsr-63236 dated 18 Feb 1953.
Approximate Cost: \$495.00 with equipment spares.

TYPE CLASSIFICATION
DESIGN COGNIZANCE COMMERCIAL
PROCUREMENT COGNIZANCE
STOCK NO.
R.D.B. IDENT. NO.

EQUIPMENT SUPPLIED DATA

QUANTITY PER EQUIPT	NAME AND NOMENCLATURE	OVERALL DIMENSIONS (inches)	WEIGHT (lbs.)
1	Sound Analyzer 760-B (General Radio Co.)	10 X 11-1/2 X 18	36-1/2 (w/batt)
1	Cable and Plug Assembly		
1	Technical Manual		

