

BUREAU OF SHIPS
RADIO AND SOUND BULLETIN

No. 10



	Page
The model ATC aircraft transmitter.....	1
Painting and servicing hoist equipment and projectors of underwater sound apparatus.....	6
Installation of 7/8-inch stub supported coaxial line.....	9
Modernization of vacuum tube analyzing equipments models OD and OQ series.....	16
Standard nomenclature for frequency band designation..	17
New procedure for ordering piezo-electric crystals.....	18
The Forum:	
Modification of model WEA-2 and QBE-1 hoist train..	21
Shorting in the shielded cable of model DAE direc- tion-finder equipment.....	22
Technical papers.....	23

APRIL 1, 1943

RADIO AND SOUND BULLETIN

NAVY DEPARTMENT,
BUREAU OF SHIPS,
April 1, 1943.

THE MODEL ATC AIRCRAFT TRANSMITTER

I. INTRODUCTION

The design characteristics of the ATC transmitter, also known as ANB-T-3 transmitter, were worked out by the Bureau of Ships in order to provide multichannel operation without the necessity of using plug-in units or retuning the same unit by hand. The equipment is intended for use in larger planes such as scout, observation, and patrol planes.

The transmitter provides two frequency ranges: a high-frequency range from 2000 to 18200 kilocycles, and a medium-frequency range from 200 to 1500 kilocycles. Three types of emission are available, C. W., M. C. W., and voice. When operated on voice modulation either carbon or dynamic microphones may be used.

The complete transmitter comprises the following units: the transmitter, dynamotor power supply, two antenna loading coils (200-600 kc. and 500-1500 kc.), pilot's control box, and antenna capacitor unit. (See fig. 1).

II. FREQUENCY SELECTION

The principal feature of the ATC transmitter is the automatic frequency selection system which it employs. Quick and accurate selection of frequency is accomplished by means of the Autotune system of the Collins Radio Co. The Autotune system is an electrically controlled means of mechanically repositioning adjustable elements such as tap switches, variable inductors, variable capacitors, etc. These several controls can be repositioned to any one of several predetermined settings. The accuracy of repositioning is of a very high order and is not materially affected by wear, humidity, or temperature. The time required for the Autotune to automatically retune all controls does not exceed 25 seconds at room temperature and with normal battery voltage. It is possible to change the present position of any control even while the transmitter is in operation. The procedure for initial adjustment of the present frequencies is similar to that normally followed for tuning any conventional equipment, and no tools are required.

Restricted

NOTICE.—Attention is invited to article 75½, Navy Regulations, 1920. The contents of this Bulletin are not to be made known to persons not in the naval service. Responsible civilians in naval employment are in this connection considered in the naval service.

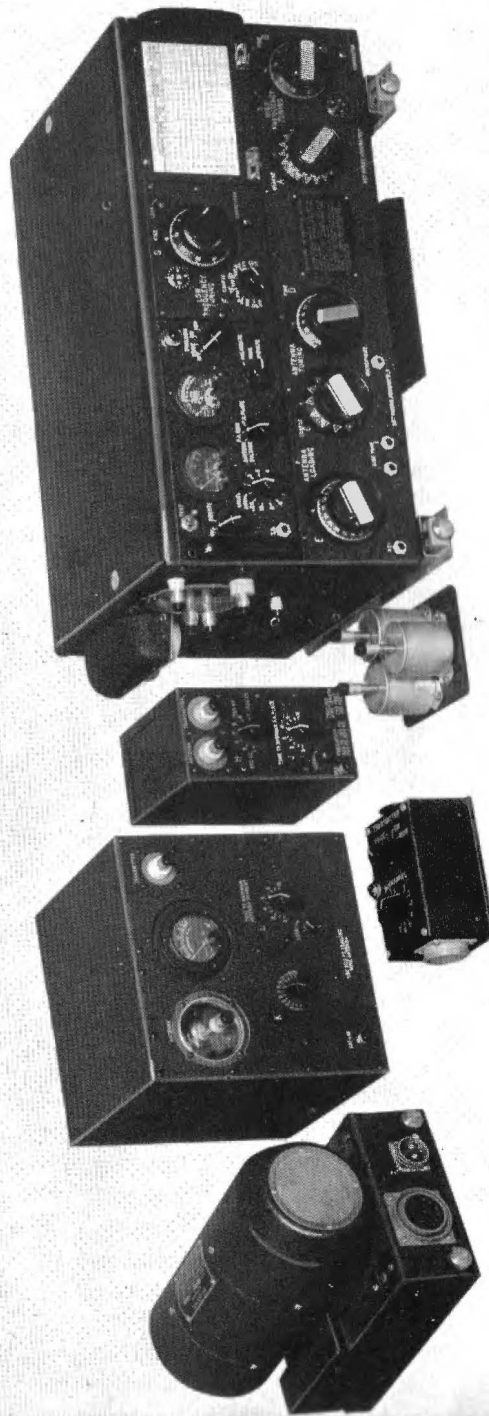

FIGURE 1.—The model ATC aircraft transmitter, showing component units: dynamotor, two antenna loading coils, pilot's control box, antenna capacitor unit, transmitter.

The design of the Autotune selection system is based on the rotating cam positive mechanical stop principle. Its reset accuracy derives from its returning to an initial starting position before progressing to the selected position.

The Autotune system permits transmission on any one of 11 preset frequencies, one of which is in the range 200 to 600 kilocycles or 500 to 1500 kilocycles and 10 of which are in the range of 2000 to 18100 kilocycles. Channel selection is made by means of a channel switch on the front panel or on the remote control box.

The operation of the Autotune is such that once the several frequency selections are adjusted, any one selected frequency can be changed without disturbing the other frequency settings. Further, when the selector switch is placed in the "manual" position, the transmitter frequency is continuously variable. Then by reverting back to the automatic operation the 10 initially selected channels are immediately available without having been disturbed by the manual operation.

III. ELECTRICAL CHARACTERISTICS

Two radio frequency circuits are employed; one circuit covers the range of 200 to 1500 kilocycles and the other from 2000 to 18100 kilocycles. In the medium-frequency range a 1625 beam power tube is used. This will operate in the range of 200 to 1500 kilocycles, so that the output is fed directly to the power-amplifier tube without frequency multiplication. The high-frequency circuit employs a type 837 tube as an electron coupled oscillator which is capable of operating within a range of 1000 to 1510 kilocycles. This tube in turn drives an intermediate power amplifying stage. By frequency multiplication the output of this stage covers the range of 2000 to 12000 kilocycles. A second harmonic amplifier is switched into the circuit to cover the range of 12000 to 18100 kilocycles giving a total of 12 frequency multiplications.

The oscillator circuits are inductively tuned by moving metal stubs in and out of the inductance coils. This adjustment is controlled by the Autotune mechanism.

Thermal reset-type protective fuses are used in the dynamotor and filament circuits.

An emission switch is provided for "on" and "off" control, voice, CW, or MCW operation. A switch is also provided wherein the equipment may be operated in either a calibrate, tune, or operate position. "Tune" position is essentially the same as "operate" except that one-half the power is applied to the power amplifier. A common meter is provided to indicate proper operating values for P. A. plate, P. A. grid, second I. P. A. grid, and first I. P. A. grid currents; also the oscillator plate, sidetone-amplifier plate, the first and second audio-ampli-

fier plate currents, and the input volts. An antenna ammeter or resonance-indicating meter is provided to indicate antenna current. A crystal frequency indicator circuit is built into the equipment to furnish beat frequencies to both the high- and medium-frequency master oscillators. A calibration chart is provided for approximate settings of the M. O. dials. Sidetone output is provided for all three type emissions. A pilot light is provided to indicate when the set is in operating condition after changing channels with the Autotune.

Circuits are so designed that turning any switch or attempting to change channels when the key or voice circuits are in operation will not damage the equipment. Conversely, if the key should be closed while the Autotune is operating, no damage will result to the equipment.

Two external antenna load coils are required for operation in the medium-frequency range. The large coil is necessary for 200 to 600 kilocycle transmission and the small coil for 500 to 1500 kilocycle operation. These load coils are manually adjusted for the particular frequency which is preset in this range. Thereafter the load coil is automatically switched into the antenna-tank circuit whenever that frequency is used. In the event that manual-frequency selection in the medium-frequency range is used, it is also necessary to manually tune the proper load coil to resonance for each change in frequency. These load coils are used in connection with trailing wire antennas of not over 200 feet in length. No modifications in the transmitter are required for use of either loading coil.

When operating in the high-frequency range of the equipment, a fixed antenna is used. At the low end of the range, between 2000 and 3000 kilocycles, the capacity of the fixed antenna may be too low for satisfactory operation. The required capacity is indicated in the following table:

Lowest desired operating frequency	Capacity of antenna at this frequency must be at least
<i>kc.</i>	<i>mmfd.</i>
2000	155
2200	125
2400	100
2750	75

If the antenna does not have enough capacity to operate at the desired frequency, then the difference between the actual antenna capacity and the required capacity shown in the table must be made up by connecting fixed shunt capacitors between the terminals on the transmitter marked COND. and GROUND. Three 25 mmfd. capaci-

tors are supplied with each equipment. These are to be used singly or connected in parallel to make up the required capacity.

IV. MECHANICAL CONSTRUCTION

With the exception of a central casting in the Autotune unit, box construction of stamped sheet aluminum is employed throughout. Several subunits are employed to facilitate assembly, dismantling, and to enable ready access to enclosed components. Three of the subunits in the transmitter—namely, the medium-frequency oscillator unit, the M. C. W.-C. F. I. unit, and the audio amplifier unit—may be readily removed for checking and replacement of parts. The three units have been equipped with multiterminal connector plugs to permit the removal of subunits from the transmitter without the use of a soldering iron. This type of construction possesses the advantages of reduced weight, material saved, compactness, and accessibility of components for replacement or adjustment.

The vibration test to which the transmitter has been subjected indicates satisfactory operation under service conditions. This test included mounting the transmitter on a vibration table capable of a maximum excursion of approximately 0.064 inches at a frequency of from 10 to 50 cycles per second. The frequency change due to vibration was only 0.025 percent at 6600 kilocycles. Voice operation was also satisfactory during vibration, and the CW and MCW carrier remained clear without noticeable waiver or wobble.

V. TUBE COMPLEMENT

The following tubes are used in the transmitter:

837	H. F. oscillator.
1625	First multiplier.
1625	Second multiplier.
813	Power amplifier.
811	Modulator.
811	Modulator.
1625	Low-frequency oscillator.
12SJ7	Speech amplifier.
6V6GT	Sidetone amplifier.
6V6GT	Speech driver.
12SJ7	MCW oscillator.
12SJ7	Crystal calibrator.

VI. POWER

The power output of the ATC transmitter will depend upon the antenna used and the degree to which it is matched to the transmitter. For a typical installation, the output in the 200 to 1500 kilocycle range will be between 5 and 75 watts; in the 2000 to 18000 kilocycle range between 30 and 90 watts.

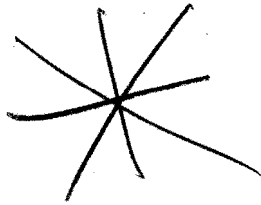

PAINTING AND SERVICING HOIST EQUIPMENT AND PROJECTORS OF UNDERWATER SOUND APPARATUS

It is the purpose of this article to list the necessary instructions for painting and servicing the hoist equipment and projectors of underwater sound apparatus. The operations indicated should be performed where applicable as soon after the ship is drydocked as possible.

Before the fouling is dry, clean all exposed radiating and corrosion resisting surfaces of retractable, nonretractable (fixed), and "torpedo" or "fish" type domes, and of the projectors. This should be done with nonmetallic and nonabrasive brushes or with wooden scrapers. Remove old paint with solvent; remove potting compound from all recesses. Clean growth and scale from the other surfaces of the projector and dome.

Remove both fixed and retractable domes where used and repeat the above cleaning process on the then accessible corrosive resisting surfaces. This should include the inner walls of the domes and sea chest, as well as traveling bearings and guides.

Extend and retract the projector (all fixed domes should be removed) or retractable dome several times with a qualified mechanic observing the operation to detect any faults or lack of smoothness.

With the dome, raft, and hoisting screws completely removed from the directing gear, service the hoist-train equipment on retracting gear. Grease as necessary and tighten all loose parts before reassembling.

Remove the oil or prestone solutions from the "torpedo" or "fish" type domes and wash thoroughly with gasoline or other solvent. Then refill with salt water, 50 parts by weight of salt to 1,000 parts by weight of fresh water plus 10 parts by weight of dry sodium or potassium chromate as a rust inhibitor. The faces of projectors housed in these types of domes should not be painted or coated.

The bearing surfaces of traveling bearings, shafts, slides, and guide rods should be coated with a thin film of water resisting rust preventive compound, grade I, Navy Department specification 52C18.

If corrosion has set in, the diaphragms of echo sounding projectors should be treated in the following manner: First spray on one thin coat of lead-chromate primer, No. 42-A. Allow 4 hours to dry. Then brush on one coat of cold plastic antifouling paint, Mare Island formula No. 143E (red) or No. 145 (black) or Norfolk formula 65-5-F

(red). The antifouling paint is to be brushed out as thin as possible. This protection will be effective for about eight months.

Rubber hemispherical sections and rubber-covered flat diaphragms of projectors should be coated with a solution of chlorinated rubber in xylol, plasticized with castor oil, formula No. 94.

The following parts should not be painted: the corrosion-resisting surfaces of sound transparent windows of all types of echo-ranging domes (outside and inside); the corrosion-resisting diaphragms of all flat echo-ranging projectors; and the corrosion-resisting hemispherical covers of spherical projectors. If these have been painted, the paint should be removed with paint or varnish remover, specification 52-R-12, and the surface cleaned with solvent. The surfaces should be polished but only with bright work metal polish. Avoid scratching the surface, and all corrosion resistant surfaces must be considered fragile.

All remaining areas should be coated in the same manner as the ship's bottom. After final setting up on plugs and bolts, all recesses of underwater sound equipment should be filled with potting compound.

In the case of magnetostriction projectors which are not housed in domes, the oil or prestone solution should be drained from the hemispherical cover section. The cover is then removed and washed off with carbon tetrachloride. After the projector is reassembled it should be filled with salt water, 50 parts by weight of salt to 1,000 parts by weight of fresh water plus 10 parts by weight of dry sodium or potassium chromate as a rust inhibitor. Prestone solutions should not be used.

Retractable strut and retractable necked type domes should be filled with sea water.

The following comments apply to watertight streamlined fixed-type domes which have been or are being installed over standard QC spherical projectors. First, remove the corrosion resisting hemispherical covers. In the case of equipment manufactured by the Submarine Signal Co. these covers may be removed by taking out the cap screws and lifting the cover clear. In the case of spherical projectors manufactured by the Radio Corporation of America, the clamping ring that holds the projector together is a part of this cover assembly. The thin corrosion-resisting steel hemisphere can be removed from the clamping ring either by the application of a moderate amount of heat at the point where it is sweated onto the clamping ring or by sawing it off at the same ring joint. Then fill the watertight dome with salt water, 50 parts by weight of salt to 1,000 parts by weight of fresh water plus 10 parts by weight of dry sodium or potassium chromate as a rust inhibitor.

The covers removed from the Submarine Signal Co. projectors should be left on board the vessel for possible use in case the streamlined dome should be lost or damaged but without substantial damage to the projector itself.

Flood and vent pipe lines should be fitted to provide a means for filling the watertight dome and sea chest. The vent pipe should be taken from a point between 4 and 8 inches below the sea chest flange to another point well above the water line. This vent line should be open at all times when the equipment is in use in order that the volume added by the shaft when the projector is lower will not rupture the dome by excessive pressure.

INSTALLATION OF 3/8-INCH STUB-SUPPORTED COAXIAL LINE

The use of 3/8-inch stub-supported coaxial line in certain radar installations makes it desirable to publish herewith a special report on the installation of this line. These instructions were prepared by personnel of the Radiation Laboratory, Massachusetts Institute of Technology, in collaboration with Navy Yard Boston.

I. INTRODUCTION

This instruction book has been prepared in order to facilitate the installation of the 3/8-inch stub-supported coaxial line for use with

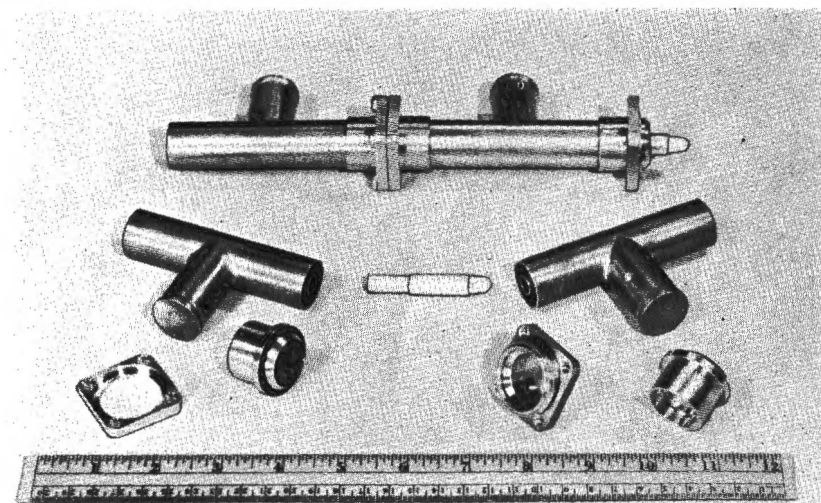

FIGURE 1.—Photograph showing stub supported line fittings : stub couplers, male and female couplers, locking rings, slotted bullet, and assembled unit.

certain radar equipment. Its object is to instruct uniformly all navy yards and other activities in proper installation procedure.

In order to facilitate the installation, it is desirable to have fabricated as much of the line in a shop or factory as possible. For this reason prefabricated sections of line and also special coupling elements are supplied. Since these lines cannot be bent, and since it will be necessary to cut the prefabricated line to length for a given installation, it is recommended that accurate sketches be made of the installation before proceeding, noting particularly the possible orientation

of the stubs with respect to the mounting brackets. Also, the relative orientations of the right angles should be noted carefully.

The coaxial transmission line is used to transmit electrical energy from the transmitter to the antenna unit of various models of radar

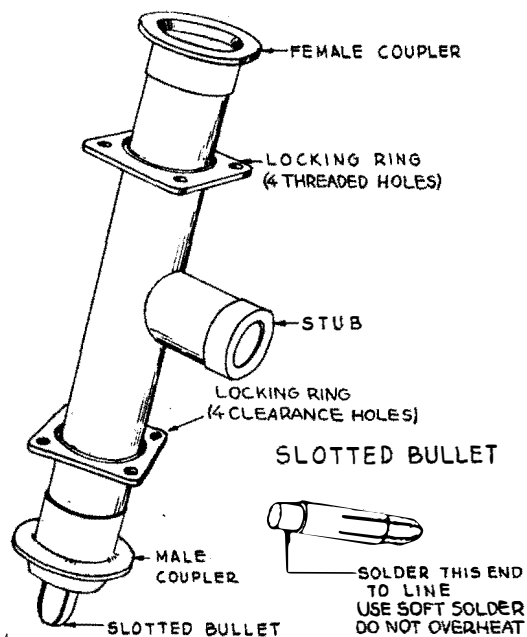
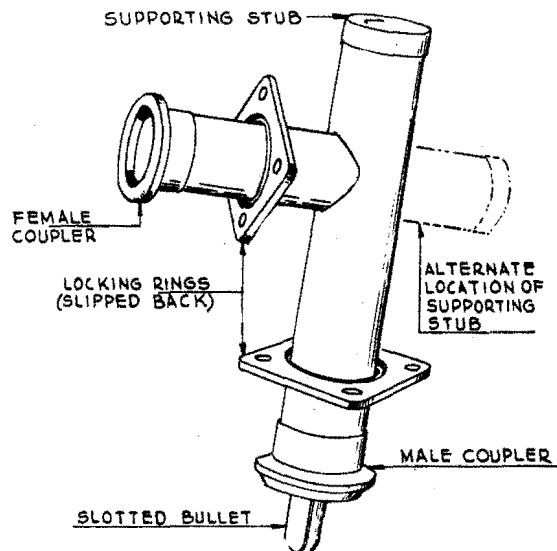

FIGURE 2.—Stub coupler.



NOTE THAT STUB MAY BE LOCATED IN LINE WITH EITHER MALE OR FEMALE COUPLER. BOTH TYPES ARE SUPPLIED

FIGURE 3.—Stub right angle.

equipment. The material in this manual consists of certain details of the mechanics of preparing and installing $\frac{7}{8}$ -inch stub-supported lines and fittings.

The outer conductor of the transmission line is $\frac{7}{8}$ -inch O. D. copper tubing having a wall thickness of 0.32 inch. The inner conductor of the transmission line is $\frac{3}{8}$ -inch O. D. copper tubing having a wall thickness of .032 inch. In addition to the prefabricated sections of line, there are included certain loose fittings. These include:

- (a) Special pressure couplers and locking rings.
- (b) Slotted "bullets" for connecting adjacent sections of inner conductors.

These fittings are illustrated in figures 1, 2, and 3.

II. MECHANICAL REQUIREMENTS

In order to obtain the proper electrical performance, the following rules should be closely observed:

- (a) There should be no bends in the lines although slight offsets such as required to follow the rake of a mast are permissible.
- (b) The securing of sections of lines together must be done only after the ends of the lines have been carefully cleaned. The slotted bullet must be sprung open so that it makes firm contact into the $\frac{3}{8}$ -inch O. D. tubing of the following section.
- (c) In coupling two flanges together, the faces should be drawn together with considerable force. The design of the coupler and the coupling ring assembly assures that the two faces will be drawn together evenly.
- (d) There must be no protuberances of any kind on the inner wall surfaces of the outer conductor or the outer surface of the inner conductor. Special attention must be taken to be sure that no sharp edges result from poor cutting or poor fit and that solder globules are avoided.

III. FABRICATING LINES

Although the line is not subjected to any static pressure, provision is made in the design of the equipment to maintain a continuous flow of air through the line at all times.

Five 12-foot sections of the stub-supported transmission line, prefabricated at the factory, are supplied for each installation. The distances between the stubs supporting the inner conductor are not uniform, but vary from 21 to 27 inches. This has been done in an effort to reduce the possibility of a serious mechanical resonance along the entire length of line. A drawing showing an assembly of such a line is given in figure 4.

When it becomes necessary to use less than a full length of line, thereby requiring that the line be cut, several details must be observed very carefully.

- (a) Cut the inner and outer conductors to the same length.
- (b) Remove all burrs.
- (c) Soft solder the appropriate half of the coupling flange to the outer conductor. If the male half of the coupler is being used,

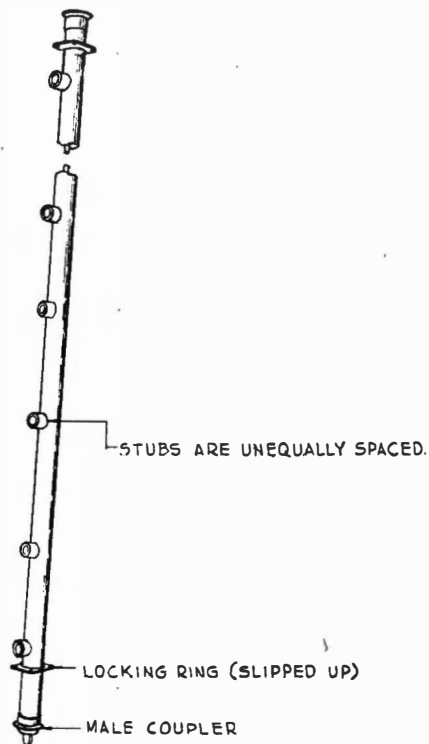

FIGURE 4.—Typical section of stub supported coaxial line.

the inner conductor bullet must be soft soldered into position before the flange is soldered.

(d) A coupler of the type used on these installations adds one inch to the length of line. That is, the “faces” of the male and female couplers are each one-half inch from the ends of the outer conductor in them.

NOTE.—The free distances from the end of the line to the nearest stub should not exceed 4 inches. If the distance is greater than 4 inches, cut the line $4\frac{1}{2}$ inches less than is required and use a stub coupler.

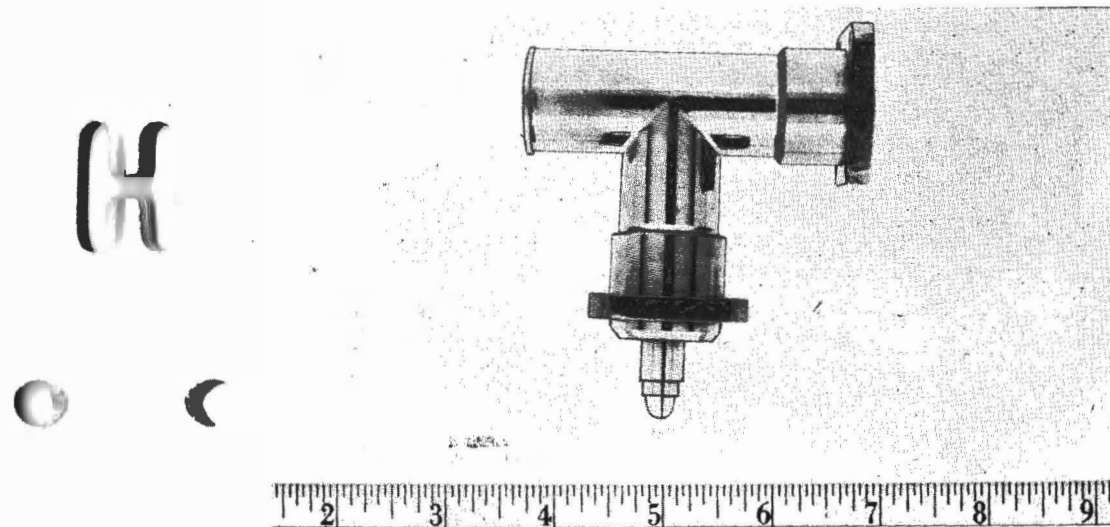

FIGURE 5.—Photograph of stub right angle. As shown here one end of the bullet is soldered into the line, the slotted end having its ends spread before coupling.

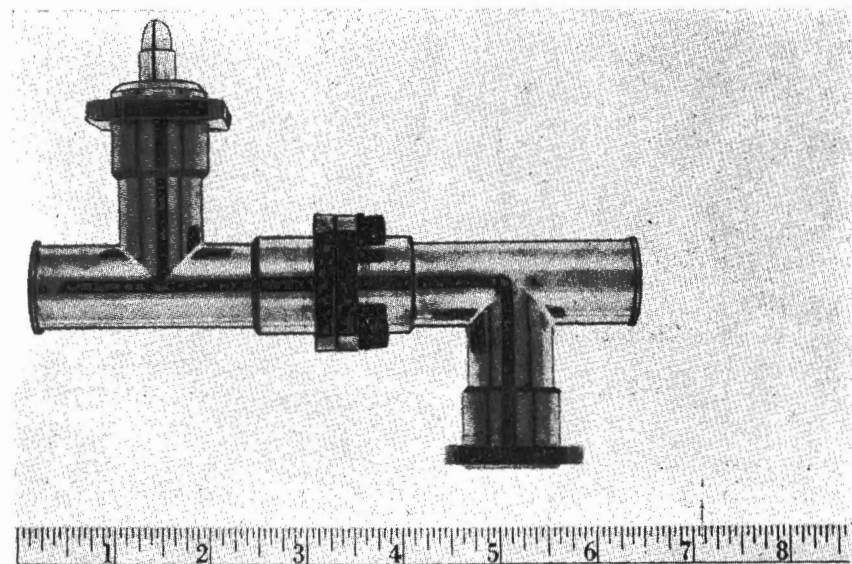

FIGURE 6.—Photograph of two stub right angles coupled together. This is the type of coupling used throughout the system. Four screws hold the coupling rings together. The coupling ring which has the threaded holes goes on the female coupler. This convention must always be observed.

IV. CONNECTING STUB ANGLES

The procedure involved in connecting the stub right angles is substantially the same as that involved in connecting sections of the line. The two sections of line to be connected must be provided with the appropriate halves of the coupler flanges, and the male flange must be accompanied by the bullet soldered to the inner conductor. Assembly is made as for the lines. See figures 5 and 6.

V. PASSING THROUGH DECKS AND BULKHEADS

A standard 7/8-inch pipe sleeve coupling W. T. deck or bulkhead connection should be used. With no coupling, a length of line may be inserted through the bulkhead and a coupling soft-soldered on to continue the installation. See figure 7.

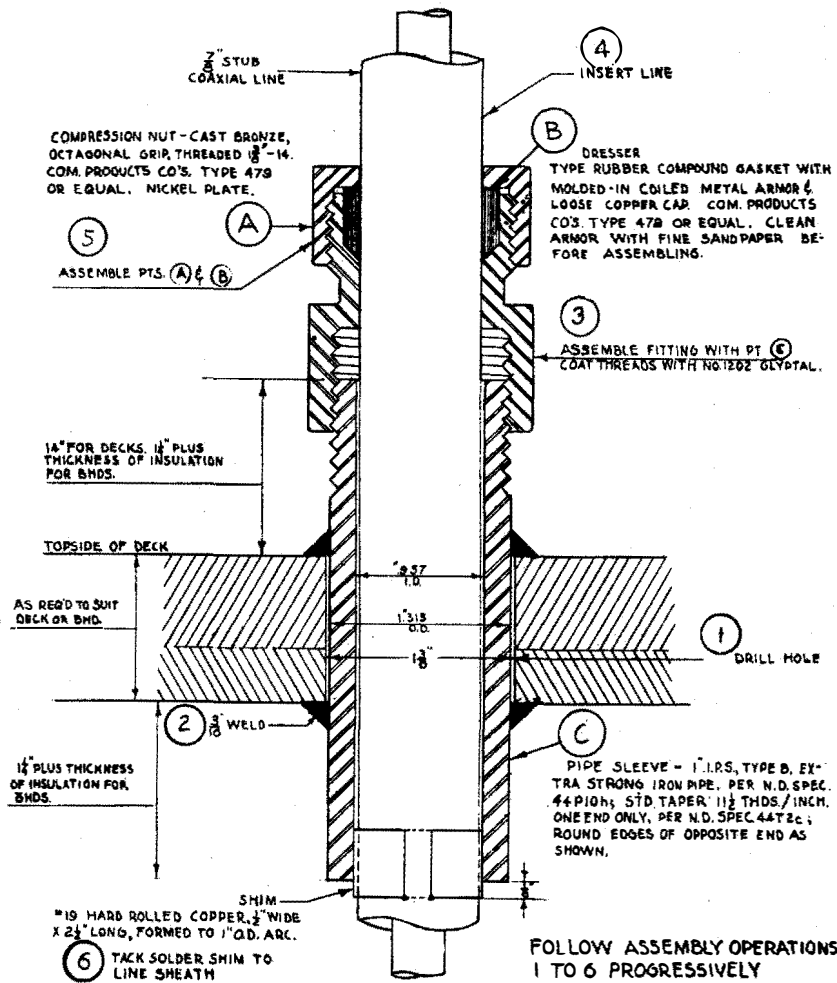

FIGURE 7.—Diagram showing typical W. T. deck or bulkhead connection.

VI. HANGERS

To support the run of the transmission line, hangers of flat bar steel may be made up. The accompanying sketch, figure 8, indicates one design that may be employed. If standard pipe hangers are available, these may be used. To take care of expansion of the line, the hangers should be lined with a thin sheet of lead. This will allow the transmission line to slide in the hanger.

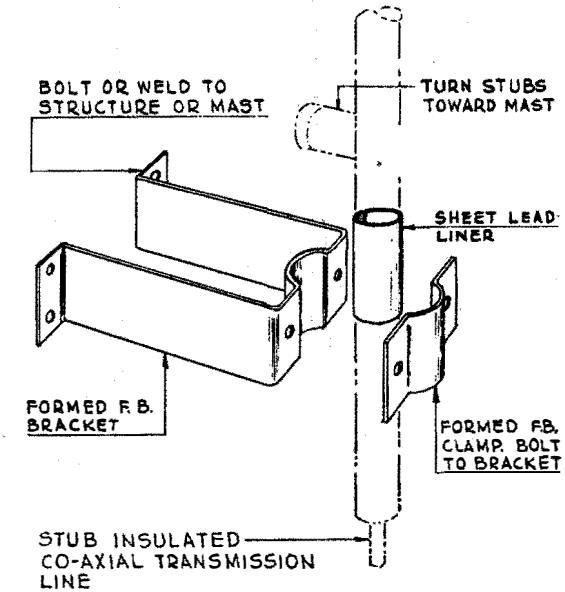

FIGURE 8.—Diagram of hanger for 3/8-inch diameter transmission line.

MODERNIZATION OF VACUUM TUBE ANALYZING EQUIPMENTS, MODELS OD AND OQ SERIES

Many of the tube testers installed on shipboard or at shore stations were constructed prior to the advent of the miniature, loctal, or acorn tubes. In addition, many types of tubes of the 4, 5, 6, 7 or octal pin basing are of recent design.

In order to obtain the best use of the existing equipment for testing receiver vacuum tubes, a recent program of modernization has been initiated by the Bureau. Under contract NXs-3983, the Weston Electrical Instrument Corporation has manufactured adapters and obtained test data for the new tubes. In the case of the Model OD equipment, modified to Model OD-a by a kit which contained octal socket parts, the Bureau decided that the most satisfactory method of modernizing was by furnishing a complete new top panel. The modified equipment will be known as the Model OD-b and will have a new instruction book furnished with the panel. The Models OD-1, OD-2, OD-3, and OD-4 do not require as extensive a change, and the following adapters are being furnished as needed to enable the equipment to test the newer as well as the older types of tubes:

(1) The miniature adapter is listed as Navy type CV-49398, Weston D-106196. This has a miniature 7-prong socket and an octal base. It should be used in the octal socket of the OD equipments with patch cord connections made in accordance with the data shown in the revised data tables. This adapter will be required to test miniature tubes in the Model OD-1, OD-2, OD-3, and earlier OD-4 equipments.

(2) The loctal adapter, Navy type CV-49596, Weston D-106197, is equipped with a loctal socket and an octal base. It should be used in the octal socket of the OD equipments with patch cord connections made in accordance with the data listed in the revised data tables. This adapter is required to test loctal tubes in the Models OD-1, OD-2, OD-3 and earlier OD-4 equipments.

(3) The acorn adapter marked "ATA" is listed under Navy type CV-49397 and Weston D-70193. This adapter is equipped with a special acorn socket and a six-prong base. It should be used in the six-prong socket of the OD equipments with patch cord connections made in accordance with the data listed for acorn tubes in the revised data tables. This adapter is required to test acorn tubes in the Models OD-1, OD-2, OD-3, and OD-4 equipments. The operator should be careful when inserting or removing tubes from the acorn adapter as these tubes are easily damaged when strains are applied to the wire terminals coming directly through the glass seal.

The revised data table contains information on many of the newer types not listed in the old OD series instruction books, including data for testing miniature, loctal, and acorn types with adapters. Values of end of useful life listed in the new tables are the present accepted values. These tables are furnished with each modernization kit and supersede data previously given in the original instruction books.

Miniature types of tubes may be tested in the Model OQ equipments by making use of the miniature adapter supplied under Navy type CV-49398, Weston D-106196. This adapter has a miniature socket and an octal base. When testing these tubes the adapter should be placed in the octal socket of the Model OQ and the patching connections made in accordance with the instructions listed for each tube type. The instructions of the data sheet furnished with each adapter are made up in the same form as those used on pages 11 through 15 of the OQ instructions book. The Model OD-5 and Model OQ-1 need no adapters as all changes have been already accomplished on this or later equipment by the inclusion of all tube sockets on the basic panels.

☆ ☆ ☆

STANDARD NOMENCLATURE FOR FREQUENCY BAND DESIGNATION

The Combined Communications Board has adopted the following frequency designation table as the standard nomenclature for the United Nations:

Designation of radio waves according to frequency	Authorized abbreviations	Frequency in kilocycles per second
Very low.....	VLF	Below 30.
Low.....	LF	30 to 300.
Medium.....	MF	300 to 3000.
High.....	HF	3000 to 30000.
Very high.....	VHF	30000 to 300000.
Ultrahigh.....	UHF	300000 to 3000000.
Superhigh.....	SHF	3000000 to 30000000.

NEW PROCEDURE FOR ORDERING PIEZO-ELECTRIC QUARTZ CRYSTALS

A new procedure has been authorized by the Bureau for the expeditious ordering of piezo-electric quartz crystals. It is believed that much time and paper work will be saved through the use of form NBS 370 for the procurement of replacement crystals or crystals for newly assigned and authorized frequencies. Form NBS 370 is reproduced in this bulletin (fig. 1) for the information of the service, and a limited number of these forms bound in pads of 100 sheets each are being forwarded to the various navy yards and other naval activities. Additional quantities may be obtained upon application to the Bureau of Ships on form NBS 20-1 (ships) or NBS 20-2 (shore).

This procedure is intended to replace that outlined in chapter 31, paragraphs 188 and 189, of the Manual of Engineering Instructions and the following is the proposed revision of the two paragraphs:

I. REQUEST FOR CRYSTALS

The Navy Yard, Washington, is the supply yard for piezo-electric crystals. Crystals shall be requested from the Navy Yard, Washington, via the chain of command, with a copy to the Bureau of Ships (Radio Division). These crystals are ground in the crystal laboratory, Navy Yard, Washington, D. C., or at other points when obtained commercially, to specifications given by the Bureau for the grinding of crystal. Crystal orders shall be on form NBS 370 which provides for inclusion of information on the required crystals and holders, or where the above form is not available, information shall be in accordance with the following:

1. Date needed.
2. Shipment destination and suggested method of shipment.
3. Ship or station requiring the crystals.
4. (a) Navy model (or type number) and serial number of equipment for which required.

(b) If the equipment has not been assigned a Navy model or type designation through the Bureau of Ships, it will be necessary to give the manufacturer's name, address, and the designation of the equipment.

(c) Indicate whether the crystal is for use in a transmitter, receiver, CFI, or frequency meter.

NBS 370
867/40 (Serial No. _____) Date _____

From: _____
To: The Commandant, Navy Yard, Washington, D. C.
VIA: _____

SUBJECT: Radio, Rader, and Underwater Sound Equipment-Request for Piezo-Electric Quartz Crystals.

Reference: (a) Bureau of Ships Manual, Chapter 67.

(1) Date needed _____ (2) Required by _____
(Ship or Station)

(3) Ship to _____ VIA _____
(Airmail, express, etc.)

(4) For use in Type _____: Trans. _____ Rec'r. _____ CFI _____ Freq. Meter _____
Unit of (a) Navy Model _____ Equipment, Serial No. _____
* (b) Commercial Type _____ Manufactured by _____
(Company) (Address)

(5) Crystal Holder (a) Navy Type _____
* (b) Commercial Type _____ Manufactured by _____
(Company) (Address)

*Physical dimensions: Width _____ Depth _____ Height (exclude pins) _____ inches.
*Pins: Number of _____ Spacing of _____ Size of _____ inches diameter.
*Size of crystal blank: _____ inches by _____ inches.
*Electrode type: Pressure air gap _____ Air Gap _____ Plated _____ Other _____
*Note: Section 4 (b) to be used only if equipment is without Navy Model or type designation. Section 5 (b) to be used only if section 4 (b) is filled in and no sample holder is forwarded with request. Dimensional sketch of holder permitted and may be placed on reverse side of this form.

(6) Temperature of operation of crystal _____ °C.
(7) Accuracy of frequency: ± _____ % (8) Crystal osc. tube: Type _____ Plate volts _____

(9) Quantity	To be filled in by requesting agency.		To be filled in upon completion of order.			
	Frequency in Kcs. Crystal	Channel	Serial No. of Holder	Type of Holder	Date Shipped	Remarks

(10) Rec'r I.F. _____ Kcs. (Osc. freq. of recr. applied to detector or mixer tube is higher _____ lower _____
than incoming channel freq.)

(11) Remarks, special type of operation, multiplication of frequencies, etc. _____

Signed _____ Approved _____ (date)

Distribution: 1 copy for office of origin,
4 copies for Navy Yard, Washington
1 copy for Bureau of Ships

Note: If insufficient space use reverse side beginning this end for additional data or comment on respective items by number. 87240

FIGURE 1.—Reproduction of form NBS 370 for the procurement of replacement crystals.

5. Where crystals are required for transmitter or receiver frequency control, state the channel frequency, i. e., the transmitter output frequency, or the receiver input frequency. State the receiver intermediate frequency and whether the oscillator frequency applied to the detector or mixer tube is higher or lower than the incoming channel frequency. Where the crystal is used in a filter circuit, state the filter frequency.

6. Actual frequency to which crystal should be ground. Where this frequency is different from the channel frequency, crystals will be furnished for the channel frequency. Consideration will be given to the proper circuit operation, i. e., whether doubling, tripling, etc., is employed and for the intermediate frequency in the case of receivers.

7. Indicate the method whereby the output frequency is obtained in the transmitter or the heterodyning frequency is obtained in the receiver, i. e., by doubling, tripling, etc., where the apparatus is not assigned a Navy model designation.

8. Accuracy in percent of crystal frequency to which the crystal should be ground. State whether crystal is to be operated at room or oven temperature. If the crystal is used in temperature compartment, state oven temperature.

9. Type of vacuum tube used in the crystal circuit and the voltage applied to the plate of the tube.

10. Navy type number of the holder, or if a Navy type number has not been assigned by the Bureau of Ships, give complete physical and electrical data on the holder including outer physical dimensions, spacing and number of pins, diameter of pins, electrical connections, size of crystal, and the method of holding the crystal.

11. Any special method of operation, e. g., operation of crystal at harmonic frequency (such as in Model TBS).

II. DISPATCH REQUESTS

The minimum data for dispatch request for crystals shall include:

1. Navy model designation *including* suffix numbers (e. g., TCB, TCB-2, etc., as in certain cases crystal holders and circuits have been changed in the later equipment).

2. Shipping information (as in 2 above).

3. Use of crystal (as in 4 *c* above).

4. Channel frequency (as in 5 above).

Warning: This minimum data applies only to equipment assigned a Navy model designation. For other equipment information in conformance with form NBS 370 will minimize delays due to lack of sufficient data.

III

Crystal controlled radio equipment furnished the naval service is normally provided with the initial set of piezo-electric crystals required for operation and, in certain cases, with spare crystals. Any additional crystals that may be required subsequent to receipt of the equipment, due to changes in frequency allocation, will not be furnished until specifically authorized by proper authority.

THE FORUM

AN INFORMAL DISCUSSION OF COMMUNICATION MATERIAL MATTERS OF INTEREST TO THE SERVICE

The discussions contributed to this section of the Bulletin are of great value to the Bureau. Most of the contributions in the past have been very thorough, indicating considerable time and thought on the part of the author. The Bureau realizes that the requirements of wartime service leave little time for carrying out research projects or for preparing reports. Nevertheless, the observations of personnel on the performance of Radio and Sound equipment under wartime operating conditions are of great importance.

It is hoped, therefore, that suggestions, comments, experiences, difficulties, and other matters of interest will continue to be sent in by the service. They may be prepared as briefly and informally as necessary. They should be addressed to the Bureau of Ships via the commanding officer.

☆ ☆ ☆

MODIFICATION OF MODEL WEA-2 AND QBE-1 HOIST TRAIN

The following item is taken from the Radio Installation Bulletin.

The Models WEA-2 and QBE-1 Underwater Sound Equipment, as designed, have approximately 24-inch travel of the projector between hoisted and lowered positions. In many vessels, because of construction or the position of the seachest, this is not sufficient. This may be increased to 31 inches by making the following minor modifications in the hoist-train:

(a) Modify the grease fittings and connections on the base plate such that they will not be damaged by the yoke in the extreme lowered position.

(b) Remove the stop clamp from the upper portion of the hoist shaft to permit a 31-inch travel.

(c) If the upper ring is used for clamping, the two lower locating rings of the hoist shaft should be filled with Babbitt metal so that no shoulder or recesses exist at this point. Fill the one lower ring if the center ring is used for clamping.

Care should be taken not to use this extreme lowered position at vessel speeds of over 15 knots, or in very heavy sea, as this position results in a greater strain being placed on the mechanism.

TECHNICAL PAPERS

SHORTING IN THE SHIELDED CABLE OF MODEL DAE
DIRECTION-FINDER EQUIPMENT

The following report has been received from A. O. Bliss, Assistant Radio Engineer, U. S. Naval Operating Base, Key West:

The 5-foot shielded radio frequency cable furnished with the Model DAE direction-finder equipment for interconnection between the loop and receiver often shorts out. This is caused by the insulated segments pulling apart enough to permit the braided shield to enter between segments and short out the loop conductors. Where this occurs, correction can be made as follows: Remove end fittings, outer rubber cover, cloth cover, and shield. Pull each segment apart slightly and make sure no broken wires from the shield are lodged between the segments. Put a drop of solder just large enough to retain the segment at one end of the cable. Hold the opposite end of the cable and force the segments together with moderate pressure and then put a drop of solder on each wire to hold the segment at that end. This will hold the segments together. Now lay on a flat surface and wrap with transparent scotch tape, keeping the tape at approximately a 45° angle. Cover with a new piece of copper braid ($\frac{3}{8}$ inch wide when flat). If exposed to weather, wrap with friction tape and paint.

Bureau comment.—Separation of the insulated segments may also cause shorting between the two inner conductors due to twisting of the cable. The suggested procedure is a satisfactory means of correcting these difficulties. To obviate the trouble in new equipments, designs have been prepared for use of a solid dielectric cable.

(22)

The following technical papers on radio and sound subjects have been listed by the Navy Research Laboratory as received from January 15, 1943, to March 15, 1943. Requests are received from time to time by the Bureau and the Naval Research Laboratory for copies of these papers. However, there are no provisions for circulating the publications containing these articles. This list is published for the purpose of keeping interested personnel informed on the current literature in the field.

(NOTE.—Asterisk (*) preceding entry indicates that an abstract only is available in the library.)

Aircraft:

- New uhf landing system at LaGuardia.* Electronic Ind. 1; 62-64; Jan. 1943.
Snowstorm shifts radio beam. Electronic Ind. 1; 47; Jan. 1943.
Aircraft radio maintenance. Crowley. Radio No. 276; 30-32; Jan. 1943.
Receiver design factors in aircraft communications. McKee. Comm. 22; No. 12; 22-4; and 46-8; Dec. 1942.
The flight tray, a multiple instrument indicator. Sperryscope 9; No. 3; July 1940 (NRL has reprint) 531.3.S65 (With periodicals).
Radio in air travel. Electronic Ind. 1. 84-87; Feb. 1943.
German aircraft radio equipment. Winner. Radio News 29; 10-12; Mar. 1943.
Automatic aircraft-radio recorder. Peters. Comm. 23; 11-14; Feb. 1943.

Amplifiers:

- High-sensitivity D. C. amplifiers.* Hay. W. W. 49; 9; Jan. 1943.
Behavior of a balanced D. C. amplifier. Spencer. R. S. I. 14; 10-14; Jan. 1943.
Response of video amplifiers. Preisman. Comm. 23; 29-32; Jan. 1943.
Comparison of voltage and current-feedback amplifiers. Schulz. I. R. E. 31; 25-28; Jan. 1943.
Nuevo metodo de calcula de los amplificadores clase, C. Rubin. Revista Tel. No. 363; 727-734; Dec. 1942.
High frequency response of video amplifiers. Preisman. Comm. 22; 16, 19-20, 38, 41, and 45; Dec. 1942.
Optimum conditions in class A amplifiers. W. E. 20; 53-55; Feb. 1943.
R. F. amplifiers. Radiocraft 14; 296; Feb. 1940.
**Analyzing amplifier diagrams.* Chadbourne. Int. Projectionist 17; No. 12; 7-9; Dec. 1942.
**On the mode of action of the cathode amplifier.* Wunderlich. ENT. 19 63-66; May 1942. WE 36, 1943.

Antennas:

- New circular FM antennas.* Radio-craft 14; 201; Jan. 1943.
Polar diagrams of ultra-short wave horizontal transmitting aeriels. Banerjee. Indian J. Phys. 25; 211-218; Aug. 1942.
An electromechanical calculator for directional antenna patterns. Smith. Elect. Eng. Trans. 62; 78-82; Feb. 1943.
Loop antennas for aircraft. Levy. I. R. E. 31; 56-66; Feb. 1943.
A note on the characteristics of the two-antenna array. Harrison. I. R. E. 31; 75-78; Feb. 1943.

Bridges:

Inexpensive portable capacity bridge. Poling. Radio News 29; 26-27; Feb. 1943.

A variable ratio-arm conductivity bridge. Luder. R. S. I. 14; 1-3; Jan. 1943.

Broadcast:

WABC—key station of the Columbia broadcasting system. Ostlund. Elect. Comm. 21; 61-72; No. 1; 1942.

Maintenance of broadcast in wartime. Ouimet. I. R. E. Proc. 31; 93-99; Mar. 1943.

Cathodes:

A new frequency-comparison circuit for the cathode-ray tube. Rawcliffe. I. E. E., J. 89; Pt. 3; 191-194; Dec. 1942.

Cathode follower:

The cathode follower. Lockhart. Electronic Engr. 15; 375-379; Feb. 1943.

Cathode ray tubes:

Reentrant loops on a C. R. tube. Electronic Eng. 15; 347; Jan. 1943.

Coaxial conductors:

The measurement of the characteristics of concentric cables at frequencies between 1 and 100 megacycles per second. Jones. I. E. E., J. 89; 213-220; Dec. 1942.

Communication, interior:

Priority-free radio intercom. Scott. Radio News 29, 28-29; Mar. 1943.

Condensers:

**Mica capacitor standard; first American war standard on radio.* Westman. Indus. Standardization 13; 296-8; Dec. 1942. EIS card.

Direction finding:

Bellini-tosi fixed direction finder. Pollack. Comm. 23; 33-34; Jan. 1943.

Electronics:

Electronic equipment in humid climates. Gardner. Electronic Ind. 1; 6062; Feb. 1943.

New world of electronics, a survey of all various uses of electronics with predictions. Electronics 16; 84-156; Mar. 1943.

Filters:

On effect of resistance component in wave filter elements and performance of nonideal filter sections. Ahmed. Indian J. Phys. 25; 229-239; Aug. 1942.

Frequency:

A new frequency divider for obtaining reference frequencies. Stansel. Radiocraft 14; 209; Jan. 1943.

The use of counter circuits in frequency dividers. Kent. J. Acous. Soc. Am. 14; 175-178; Jan. 1943.

Nonlinear current potential characteristics. Shelton. Electronic Eng. 15; 339-342; Jan. 1943.

Diode as a frequency-changer. Colebrook. W. E. 20; 5-14; Jan. 1943.

Diode frequency changes. James. W. E. 20; 15-27; Jan. 1943.

A new method of frequency measurements. Clark. Instr. 16; 60-62; Feb. 1943, 1.

High frequency:

Principles of micro-wave radio. Condon. Rev. Mod. Phys. 14; 341-389; Oct. 1942.

Impedance:

Making up odd impedances. Finlay. Electronic Eng. 15; 333-337; Jan. 1943.

Interference:

Dynamator filtering. Goldberg. Radio News 20; 13; Mar. 1943.

Loudspeakers:

Improved low frequency horn. Klipsch. J. Acous. Soc. Am. 14; 179-182; Jan. 1943.

**Radio loudspeaker tests pave way for better reception.* Goldsmith. Indus. Standardization 13; No. 11; 306-8; Dec. 1942.

Meteorology:

Radio sounding in United States. Pear. Electronics 16; 82-85; Jan. 1943.

Meters:

On the theory of "C" meter and its corrections. Rao. Indian J. Phys. 16; 197-203; June 1942.

Microphones:

The throat microphone. Shawn. Comm. 23; 11-12; Jan. 1943.

Military:

The tripart plan. Hart. ST 27; 19-21; Feb. 1943.

**German radio equipment.* Aircraft Eng. 14; 342-57; Dec. 1942.

Mobile:

Police FM for motorcycles. Gentry. Electronic Ind. 1, 83; Feb. 1943.

Pack communications equipment for fire fighting. Meyerson. Comm. 22; 7-11; and 42-3; Dec. 12, 1942.

Modulation:

50-kw FM at W55M. Gellerup. Electronic Ind. 1; 66-68; Jan. 1943.

The nature of an FM carrier. Tibbs. W. W. 49; 2-5; Jan. 1943.

Improved FM transmitter. Fingerle. FM3; 10-11; Dec. 1942.

A frequency-modulated resistance-capacitance oscillator. Change. I. R. E. 31; 25-25; Jan. 1943.

FM emergency equipment. Chestnut. Radio No. 276; 15-19; Jan. 1943.

FM transmission, propagation and reception. Tibbs. W. W. 49; 47-51; Feb. 1943.

Tuning indicators and circuits for frequency-modulation receivers. Rodgers. I. R. E. Proc. 31; 89-93; Mar. 1943.

Oscillators and vibrators:

Oscilador maestro de 100 watts par a 56 Mc/s, controlado a cristal. Poledo. Rev. Telegrafica 31; 675-677; Nov. 1942.

Capacitance becomes boss. Johnson. Radiocraft 14; 269; Feb. 1943.

Squegging oscillators. Hughes. W. W. 49; 52-56; Feb. 1943.

Oscillographs:

Direct harmonic studies with an oscillograph. Batcher. Electronic Ind. 1; 70-71; Feb. 1943.

Phase:

A stroboscope for the demonstration of phase differences in alternating current circuits. Collins. Am. J. Phys. 11; 38-40; Feb. 1943.

Impedance magnitude and phase angle charts. Blow. Electronics 16; 94-5; Jan. 1943.

**Design of simple phase shifting networks.* Duttera. Broadcast Engrs. J. 9; 3-7; Oct. 1942.

Electronic phono pickup. Gould. Radiocraft 14; 271; Feb. 1943.

Police:

Mobile crime laboratory. Nicholson. Radio News 29; 16-19; Mar. 1943.

Power:

Eddy-current losses in single-conductor paper-insulated lead-covered un-armoured cables of a single-phase system. Arnold. I. E. E., J. 89; Pt. 636-645; Dec. 1942.

Power—Continued.

Engine-driven emergency power plants. Troeglen. I. R. E. 31; 15-18; Jan. 1943.

R. F. power measurements. Bacon. Electronic Eng. 15; 344-345; Jan. 1943.

Public address system:

Public address systems. Hill. Elect. Comm. 21; 13-26; No. 1; 1942.

Pulse:

Simple pulse-generating circuits. Greenlee. Electronics 16; 118-124; Jan. 1943.

A versatile square wave and pulse generator. Miller. Radiocraft 14; 272; Feb. 1943.

Radio—Marine:

Maintenance of foreign marine radio. Coleman. Radio News 29; 36-37; Mar. 1943.

Radio distortion:

A new type of practical distortion meter. Hayes. I. R. E. Proc. 31; 112-117; Mar. 1943.

Receivers:

An automatic 1,000-cycle receiver. Topmiller. Comm. 22; 28-29; Dec. 1942.

Receiver input circuits. Burgess. W. E. 20; 66-76; Feb. 1943.

**Fire-prevention requirements for electric radios revised.* Smith. Indus. Standardization 14; 17-9; Jan. 1943.

Remote control:

Radio bibliography, remote control. Rettenmeyer. Radio No. 276; 39-46; Jan. 1943.

Signal Corps:

The Signal Corps and the Blue Grass State. DeSoto. QST 27; 11-15; Mar. 1943.

Signal generators:

Standard signal generators. Minter. Comm. 23; 7-10; Jan. 1943.

Television:

Automatic frequency and phase control of synchronization in television receivers. Wendt. I. R. E. 31; 7-15; Jan. 1943.

Contemporary problems in television sound. Townsend. I. R. E. 3-7; Jan. 1943.

**Some engineering aspects of portable television pick-ups.* Lubcke. Soc. Motion Picture Engrs. 39; 384-90; Dec. 1942.

**Waves in guide tubes.* Riedinger. T. F. T. 31; 40-50; Feb. 1942. WE No. 3.

On the most general solution of the Maxwell equations for closed cylindrical cavities. Ledinegg. Ann. der Physik. 41; 537-566; Aug. 1942. Mf No. 160 (OSS 481) WE 4.

Mercury lighting for television studios. Breeding. I. R. E. Proc. 31; 106-112; Mar. 1943.

Colour television development. W. W. 49; 41; Feb. 1943.

The focusing view-finder problem in television cameras. Beers. I. R. E. Proc. 31; 100-106; Mar. 1943.

Transmission lines:

Radio data charts. Sowerby. W. W. 49; 10; Jan. 1943.

The determination of high-frequency transmission line constants by measurements at special frequencies. Simmonds. Phil. Mag. 33; 904-910; Dec. 1942.

Principles of short wave radiation—II. Weber. Electronic Ind. 1; 76-79; Feb. 1943.

Transmission lines—Continued.

An analysis of R-F transmission lines. Hoadley. Comm. 23; 22-28; Feb. 1943.

Radio data charts—4. Sowerby. W. W. 49; 42-44; Feb. 1943.

Transmitters and transmission:

Coupled resonant circuits for transmitters. Korman. I. R. E. 31; 28-32; Jan. 1943.

KMPC's directional array at Beverly Hills. Pierce. Electronic Ind. 1; 72-75; Feb. 1943.

FM's new W75NY. Electronic Ind. 1; 80-82; Feb. 1943.

Production of transmitter frames. Gunther. F. M. 3; 10-13; Jan. 1943.

Tuning:

Tuning by inductance variation. Silver. F. M. 3; 6-7; Jan. 1943.

Vacuum tubes:

Fluctuations in space-charge-limited currents. Bell. I. R. E. J. 89; 207-212; Dec. 1942.

Velocity-modulation U. H. F. generators. Boeking. W. W. 49; 16-18; Jan. 1942.

Water-cooled transmitting tubes. Walker. Comm. 23; 20; Jan. 1943.

Characteristics and socket connection. RCA No. 1275B 1942, P-621.384-330.R1.

The saga of the vacuum tube. Tyne. Radio News 29; 25-27; Mar. 1943.

A thyratron tube tester. Stewart. Radio News 29; 20-21; Mar. 1943.

Electron control methods. Prater. Radio News 29; 14-15; Mar. 1943.

Theory of the magnetron—III. Brillouin. Phys. Rev. 63; 127-136; Feb. 1943.

Ultrashort electromagnetic waves. I—Electromagnetic theory. Weber. Elect. Eng. 62; 103-112; Mar. 1943.

War and defense:

What the Navy requires of radio. Chamberlain. Electronic Ind. 1; 42-44; Jan. 1943.

Wave propagation:

Principles of short wave radiation—1. Weber. Electronic Ind. 1; 68-73; Jan. 1943.

A study of propagation over the ultra short wave radio link between Guernsey and England in wavelengths of 5 and 8 metres (60 and 37.5 Mc./s.) Smith Ross. I. E. E. J. 89; Pt. 1; 536-538; Dec. 1942.

Current distribution along a straight wire in a uniform field. W. E. 20; 27; Jan. 1943.

U-H-F circuit contours. Haigis. Comm. 23; 17-21; Feb. 1943.

Physical behavior of wave guides. Skilling. Electronics No. 16; 76-80; 260-270; Mar. 1943.