



INFORMATION ASSURANCE
SHIPBOARD RED/BLACK
INSTALLATION PUBLICATION



DEPARTMENT OF THE NAVY (DoN)
INFORMATION ASSURANCE (IA)
PUBLICATION
MODULE 5239-31

Distribution:

Electronic versions of this document may be downloaded from the DoN INFOSEC/IA Web Site on the Unclassified but Sensitive Internet Protocol Router Network (NIPRNET) at <https://infosec.navy.mil> and on the Secret Internet protocol Router Network (SIPRNET) at <http://infosec.navy.smil.mil>.

For further assistance, the INFOSEC Technical Assistance Center (ITAC) may be reached at:

Commercial 1-800-304-4636

DSN 588-5428 / 4286

Local reproduction is authorized.

CHANGE SUMMARY TABLE FOR THIS PUBLICATION

In paragraph number	Reference changed from	To
A.1.1.7.4.1	A.1.1.(6).3	A.1.1.(7).3
A.1.1.7.4.3.c	B.1 (3).6.16	B.1.(2).6.16
B.1.2.2.c	B.1.(3).6.14	B.1.(2).6.13
B.1.2.6.3	Fig 3	Fig B-2
	B.1.(3).6.11	B.1.(2).6.11
	B.1.(3).6.12	B.1.(2).6.12
B.1.6.4	Fig 4	Fig B-3
B.1.2.6.9	B.1.(3).6.2	B.1.(2).6.2
B.1.2.6.10	B.1.(3).6.13	B.1.(2).6.13
B.1.2.6.12	B.1.(3).6.11	B.1.(2).6.10
	B.1.(3).6.12	B.1.(2).6.11
	B.1.(3).6.13	B.1.(2).6.13
	B.1.(3).6.9	B.1.(2).6.9
	B.1.(3).6.2	B.1.(2).6.2
B.1.2.6.16.a		Ref to Fig B-1 added
B.1.2.8.a	B.1.(3).2	B.1.(2).2
B.1.1.8.b	B.1.(3).6.17	B.1.(2).6.17

FOREWORD

Naval Information Assurance Program Publications (IA Pub) are issued by the Chief of Naval Operations (CNO) N643. The IA Pub series provides modules that guide the implementation of the policy direction established in the Secretary of the Navy Instruction (SECNAVINST) 5239.3. These modules provide procedural, technical, administrative, and supplemental guidance for all information systems, whether business or tactical, used in the automatic acquisition, storage, manipulation, management, movement, control, display, switching, interchange, transmission, or receipt of data. Each module focuses on a distinct program element and describes a standard methodology for planning, implementing and executing that element of the Information System Security (INFOSEC) program within the Department of the Navy (DoN).

This module, "Shipboard RED/BLACK Installation Guidance", provides the Information Systems Security Managers (ISSMs), Information Systems Security Officers (ISSOs), and shipboard Classified Information Processing System (CLIPS) installers with guidance and procedures to be used in new construction and ship alterations when CLIPSs are being installed on ships. This document only applies to CLIPS processing General Services (GENSER)/Collateral Information. The Director of the Defense Intelligence Agency is the cognizant approval authority for CLIPS processing Special Compartmented Information (SCI) and Special Compartmented Information Facilities (SCIFs).

This module when used in conjunction with NSTISSAM TEMPEST/2-95, RED/BLACK Installation Guidance, replaces MIL STD 1680C(SH), Installation Criteria For Shipboard Secure Electrical Information Processing Systems dated 17 March 1993

Instructions herein are issued for the information and compliance of all persons in the DoN and are effective upon receipt.

Reviewed and Approved by:
CNO N643 Louise Davidson 09/26/00

THIS PAGE INTENTIONALLY BLANK

TABLE OF CONTENTS

1.0 REFERENCES..... 1

2.0 PURPOSE..... 2

3.0 SCOPE..... 2

4.0 APPLICATION..... 2

5.0 INSPECTIONS..... 3

6.0 REPORTING..... 3

7.0 DEFINITIONS..... 3

APPENDIX A..... A-1

 DETAILED REQUIREMENTS A-1

 A.1 General. A-1

 A.1.1 Primary TEMPEST-Related Installation Standards..... A-1

 A.1.1.1 RED/BLACK Physical Separation. A-1

 A.1.1.2 Primary Power To RED Equipment..... A-1

 A.1.1.3 Telephone Installations. A-2

 A.1.1.4 Secure Telephone Unit Guidance. A-2

 A.1.1.5 NTDS Communication Section..... A-2

 A.1.1.5.1 NTDS Parallel Data Section. A-2

 A.1.1.6 Common Equipment Cabinets. A-2

 A.1.1.6.1 Television Receivers and Video Cassette Recorders and Players
Used With Baseband Video Systems. A-3

 A.1.1.7 Cable..... A-3

 A.1.1.7.1 RED Shielded Metallic Wire Cable. A-3

 A.1.1.7.2 Secure Voice Cables. A-3

 A.1.1.7.3 Cable Splices..... A-4

 A.1.1.7.3.1 Fiber Optic And Metallic Wire Cable Protected Distribution
System (PDS)..... A-4

 A.1.1.7.3.2 Cables containing Top Secret/SCI Information Outside an
Accredited Secure Space..... A-4

 A.1.1.7.4 RED and BLACK Conductor Separation..... A-4

 A.1.1.7.4.1 Metallic Conductors..... A-5

 A.1.1.7.4.2 Fiber-optic Conductors..... A-5

 A.1.1.7.4.3 Shared Metallic Wire cable Junction Boxes & Cable Entrance
Boxes A5

 A.1.1.7.5 Conductive Paths for Metallic Wire Signal and Control Lines. A-6

 A.1.1.7.6 Applications of Optical Cable Systems. A-6

 A.1.1.7.6.1 Fiber-Optic Cable Strength Members or Shielding..... A-6

 A.1.1.8 Secure Voice..... A-6

 A.1.1.8.1 Objective..... A-6

 A.1.1.8.2 Line and Signal Levels..... A-6

 A.1.1.8.3 Signal Processing Levels..... A-6

 A.1.1.8.4 Multichannel Magnetic Tape Recorders in p/c Secure Voice..... A-6

APPENDIX B..... B-1

 B.1.0 SCOPE..... B-1

 B.1.1 Scope..... B-1

 B.1.2 DETAILED REQUIREMENTS B-1

 B.1.2.1 Support of Primary TEMPEST-Related Installation Standards..... B-1

 B.1.2.2 RED and BLACK Signal and Control Line Interfaces..... B-1

 B.1.2.3 Approved Equipment..... B-2

 B.1.2.3.1 Cryptographic Equipment Cables..... B-2

 B.1.2.3.2 Electronic Equipment Cables..... B-2

 B.1.2.4 Radio Transmitting Equipment..... B-3

 B.1.2.4.1 Radio Set Controls..... B-3

 B.1.2.5 Approved Cables..... B-3

 B.1.2.6 Bonding Methods..... B-3

 B.1.2.6.1 Bonding Classes..... B-3

 B.1.2.6.2 Class B bonds..... B-3

 B.1.2.6.3 Flexible Bond Strap Fabrication..... B-4

 B.1.2.6.4 Solid Bond Strap Fabrication..... B-4

 B.1.2.6.5 Preparation for use of Bond Straps..... B-4

 B.1.2.6.6 Assembled Equipment Units..... B-5

 B.1.2.6.7 Fabricated Equipment Units..... B-5

 B.1.2.6.8 Electronic Equipment Cabinets..... B-5

 B.1.2.6.9 Equipment Mounted in Electronic Equipment Cabinets..... B-6

 B.1.2.6.10 Bonding of Non-Resilient Mounted Equipment..... B-6

 B.1.2.6.11 Bonding of Resilient Mounted Equipment or Cabinets..... B-6

 B.1.2.6.12 Bonding of Equipment Mounted on Slide Foundations..... B-6

 B.1.2.6.13 Bonding of Cryptographic Equipment..... B-6

 B.1.2.6.14 Bonding of Isolation Devices and Filters..... B-8

 B.1.2.6.15 Bonding of RED Terminal Boxes or Junction Boxes..... B-8

 B.1.2.6.16 Bonding of Shields and Armor on Cables..... B-8

 B.1.2.6.17 Bonding of Spare & Unused Metallic Wire Cable Conductors
 /Shields..... B-9

 B.1.2.6.18 Bonding of Stand-Alone Desktop Computer Equipment..... B-9

 B.1.2.6.19 Bonding of RED CCTV Equipment..... B-10

 B.1.2.6.20 Bonding of BLACK processing & non-processing equipment
 /devices..... B-10

 B.1.2.6.21 Removal of Armor..... B-10

 B.1.2.7 Electrical Perimeter Barrier..... B-10

 B.1.2.8 Temporary Installations of RED Processing Equipment..... B-10

 B.1.2.9 TEMPEST Installation Criteria Illustrations..... B-11

SHIPBOARD RED/BLACK INSTALLATION GUIDANCE

1.0 REFERENCES.

The following references are applicable along with this document to the installation of Classified Information Processing Systems (CLIPS) on US Navy ships.

- a. NSTISSAM TEMPEST/2-95, RED/BLACK Installation Guidance
- b. DoD 5105-21-M-1, Sensitive Compartmented Information (SCI) Administration Security Manual
- c. Director Of Central Intelligence Directive 1/21, Physical Security Standards For Sensitive Compartmented Information Facilities (SCIF)
- d. NSTISSI No.7002 (S), TEMPEST Glossary
- e. NSTISSI No. 4009, National Information Systems Security (INFOSEC) Glossary
- f. INFOSEC P-5239-02, Terms Abbreviations, and Acronyms
- g. INFOSEC P-5239-22. Protected Distribution Systems Guidebook
- h. MIL-STD-188-124B, Grounding, Bonding and Shielding
- i. MIL-STD-188-111, Subsystem Design and Engineering Standards for Common Long-Haul and Tactical Fiber Optic Communications
- j. MIL-STD-1310 (), Shipboard Bonding, Grounding, and Other Techniques for Electromagnetic Compatibility and Safety
- k. MIL-C-17, Cable, Radio Frequency, Flexible and Semi-rigid, General Specifications For.
- l. MIL-C-915, Cable and Cord, Electrical, For Shipboard Use, General Specifications For.
- m. Mil-C-5541, Chemical Coating On Aluminum and Aluminum Alloys
- n. MIL-C-24640, Cable, Electrical, Lightweight for Shipboard Use, General Specifications For.
- o. MIL-C-24643, Cable and Cord, Electrical, Low Smoke, For Shipboard Use, General Specifications For.

- p. MIL-T-22361, Thread Compound, Antiseize, Zinc Dust Petroleum

2.0 PURPOSE.

This guidebook when used in conjunction with reference (a) will provide the Information Systems Security Managers (ISSMs), Information Systems Security Officers (ISSOs), and shipboard Classified Information Processing System (CLIPS) installers with guidance and procedures to be used in new construction and ship alterations when CLIPSs are being installed on ships. This guidebook only defines requirements for CLIPS processing GENSER/Collateral information. Requirements for CLIPS and facilities processing SCI information are contained in references (b) and (c). This guidebook, when used with reference (a), is also intended to replace ML-STD 1680C(SH), Installation Criteria For Shipboard Secure Electrical Information Processing Systems required criteria in contracts.

3.0 SCOPE.

Reference (a) specifies RED/BLACK equipment/system installation guidance, provides an explanation of the TEMPEST policy concept, and addresses RED/BLACK considerations for facilities wherein National Security Information (NSI) is processed. Appendices (A) and (B) along with references (b) and (c) herein translate the guidance provided by reference (a) into shipboard criteria that addresses relevant equipment, hardware, and installation requirements. These appendices are based on supportive engineering and technical evaluation of past installations and operational experiences and data. Adherence to the requirements specified herein and in references (b) and (c) should result in secure installations meeting the essential requirements of reference (a)

4.0 APPLICATION.

Shipboard installations have been reviewed by Department of Navy (DoN) Certified TEMPEST Technical Authorities (CTTA) and it has been determined that the criteria contained in Appendices (A) and (B) are to be applied to all ships. Ships under construction, undergoing ShipAlt modifications, or having equipment already installed under previous installation criteria for shipboard CLIPS (MIL-STD-1680 series) or specifications developed from those criteria, in general do not require retrofitting. New installations or proposals for installation subsequent to the date of this publication will invoke these criteria. New installation requirements are covered by the following circumstances:

- a. When installing a new subsystem (for example, a tactical satellite subsystem), all components of the new system shall be installed in accordance with these criteria.

b. When replacing processing equipment in a subsystem (for example, replacement of an obsolete teletypewriter with a Navy Order Wire subsystem) the replacement unit and any newly installed connecting cables shall be installed in accordance with these criteria.

5.0 INSPECTIONS.

5.1 Installing Agency: Responsible for conducting the necessary inspections to verify compliance of CLIPS installations with specified criteria and for ensuring that all identified deficiencies are corrected.

5.2 Inspectors: Shall have completed a course of instruction based on reference (a) and this publication.

6.0 REPORTING.

A report detailing the results of the inspection, including identification of any uncorrected deficiencies, shall be submitted to the ship with a copy to Space and Naval Warfare Systems Command Systems Center (SPAWARSYSCEN) Charleston (Code 723). The inspectors shall include the dates when and where their qualifying training was completed in the report.

7.0 DEFINITIONS.

The definitions of all the terms used in this document are contained in reference (d), (e), and (f)

THISPAGE INTENTIONALLY BLANK.

APPENDIX A
DETAILED REQUIREMENTS

A.1 General. This appendix details the TEMPEST installation requirements that directly contribute to the containment of TEMPEST signals within a ships controlled space. Appendix B contains amplifying information and specific implementing directions that support the criteria herein. The special requirements for systems and shipboard facilities processing Special Compartmented Information (SCI) are contained in references (b) and (c). Unless otherwise specified, each detailed requirement shall be applicable to new construction ships of all classes and new installations in active fleet ships.

A.1.1 Primary TEMPEST-Related Installation Standards. The detailed requirements of this section shall be applicable to all Classified Information Processing Systems (CLIPS) in all locations unless otherwise specified within the individual paragraph.

A.1.1.1 RED/BLACK Physical Separation. The physical separation requirements for RED and BLACK processing equipment and wire lines are as follows:

a. A minimum of thirty-nine inches (1 meter) shall be maintained between any RED processor and:

1. Unshielded BLACK signal wires connected to an RF transmitter.
2. Unshielded BLACK power lines connected to an RF transmitter.
3. BLACK processing equipment having a nonmetallic enclosure with signal wire lines connected to an RF transmitter.

b. RED processors shall be separated from RF transmitters by ten feet (3 meters). Cellular telephones, cordless telephones, wireless Local Area Networks (LANs), and wireless Wide Area Networks (WANs) shall be treated as RF transmitters.

c. If the RF transmitter is contained in its original metallic enclosure, and a full length bonded metallic barrier exists or is placed on the sides of open equipment racks, and shielded BLACK cable is used on the transmitter, RED processing equipments may be installed in adjacent equipment racks or cabinets.

Note: Prior to 1997, the only equipment separation required in a ship was three feet between RED computer equipment and RF transmitters or any other BLACK processors with a path to the transmitter, such as control units, patch panels, switchboards, etc.. Installations made under pervious criteria shall not be reported as a discrepancy

A.1.1.2 Primary Power To RED Equipment. RED processing equipment shall not be connected to the same a.c. distribution/fuse panels as RF transmitters. This does not apply to RED processing equipment that is connected to an AC-DC-AC Uninterruptible Power Source (UPS).

A.1.1.3 Telephone Installations. The cables for any telephone either connected directly to a shore tie, or to a shore tie via a switch, shall not be routed with RED cables. The telephone instrument shall be separated from any RED data processing equipment in accordance with paragraph A.1.1.1.

Notes:

- 1. Prior to 1997, the only separation required in a ship was three feet between BLACK analog shore-tie telephones and any RED low level processor.*
- 2. Prior to 1983, the separation requirement between shore-tie telephones and any RED processor was two feet.*
- 3. Installations made under previous criteria shall not be reported as a discrepancy.*

A.1.1.4 Secure Telephone Unit Guidance. TEMPEST certified secure telephone units (includes the STU-III) can be operated as a voice terminal or connected to a data or facsimile device. No additional TEMPEST treatment is required when the secure telephone unit is used for secure voice only. When a secure telephone unit is connected to a RED processor (i.e., SDN, SFAX), the RED data cable shall be shielded, with the shield bonded to the connector shell at both ends. Observe separation requirements of paragraph A.1.1.1. The secure telephone unit can be used as a trunking device to provide an interface with a RED switch.

NOTE: Be advised that external signal line and power line filters can cause the STU-III terminals to malfunction, and are not required for TEMPEST purposes.

A.1.1.5 NTDS Communication Section. The NTDS communication section is considered to be that portion of NTDS that is processed in a serial stream, including the serial-parallel converter equipment. The NTDS communication section (for example, Link 14) shall conform with the TEMPEST-related installation requirements specified herein.

A.1.1.5.1 NTDS Parallel Data Section. Within the parallel data section of the NTDS the following shall be applied:

- a. Normal NTDS engineering practices of utilizing overall shielding and bonding shall be considered satisfactory as minimum criteria.
- b. The TSEC/KG-40A and KGX-40/TSEC shall be bonded to ground in accordance with Appendix B, paragraph B.1.2.6.13.

A.1.1.6 Common Equipment Cabinets. In surface ships, except as specified in paragraph A.1.1.1, RED and BLACK processing equipment with the exception of RF transmitters may be installed in the same electronic equipment cabinet or rack only if:

a. The original metallic enclosures of both the RED and BLACK processing equipments have not been removed.

b. Adequate shielding has been provided between the equipment as recommended and approved by the CTTA.

Note: Prior to 1997, any RED and BLACK equipments could be installed in a common equipment cabinet or rack, even RF transmitters, provided the original enclosures were maintained on both the RED and BLACK equipments. The document did not specify that the enclosures be metallic. Installations made under previous criteria shall not be reported as a discrepancy.

A.1.1.6.1 Television Receivers and Video Cassette Recorders and Players Used With Baseband Video Systems. The TV receivers and VCRs, modified for a baseband video input (or output), and processing classified information, shall be additionally modified by disabling the RF and IF strips or the receiver tuner and local oscillator and removing or disabling the RF module of the VCR.

A1.1.7 Cable.

A.1.1.7.1 RED Shielded Metallic Wire Cable. RED metallic wire cables in all locations shall be shielded, with the exception of desktop computer cables that are provided by the manufacturer, where there is not an offered shielded cable option. This requirement is not applicable to RED fiber optic cables.

A.1.1.7.2 Secure Voice Cables. Cables and conductors serving secure voice processing equipment shall be isolated in the following manner:

a. Transmit and receive audio lines shall be balanced twisted pairs with each pair nonferrous shielded, and the shields insulated from each other. Where the transmit pair and associated transmit control wires are contained in one cable, an overall nonferrous shield may be used provided the associated receive audio is contained in a separate twisted shielded pair cable.

b. When a multi-circuit cable is used, each transmit and receive audio twisted pair shall have a nonferrous shield with all shields insulated from each other, and with an overall insulating sheath.

c. In boats and craft, if a cable contains only one secure voice send/receive circuit and does not exceed 25 feet in length, the cable may have an overall nonferrous shield and an overall insulating sheath.

A.1.1.7.3 Cable Splices. Splicing of RED cables shall be avoided. If a cable must be spliced, it should be internal to the classified space and be enclosed within a metallic junction box. A cable spliced external to the classified space must comply with the requirements defined in paragraph A.1.1.7.3.1. Splicing of RED cables shall maintain the electrical and physical properties of the cable.

A.1.1.7.3.1 Fiber Optic And Metallic Wire Cable Protected Distribution System (PDS). Splicing of metallic wire or fiber optic cable runs carrying GENSER SECRET and/or TOP SECRET, SCI or any classification of Special Intelligence information external to an area accredited to that level of security should be avoided. If the cable must be spliced, the splice shall be contained within a junction box as detailed below. Sliced cables carrying SCI or any classification of Special Intelligence information must meet the requirements defined in references (b) and (c).

a. The cable shall not break out (for example, to a distribution system) at any point along its entire run except in an area accredited to that level of security.

b. Cables installed external to a secure space or other restricted area shall be installed so that they can be physically inspected. If the cable passes through normally locked spaces (for example, voids, staterooms, fan rooms, storerooms, etc.), that portion of the cable shall be contained in a metallic conduit.

c. If a junction box is required outside of the secure spaces, it shall be in an inspectable location, and have the cover tack welded shut, or it shall be locked with a combination padlock conforming with FF-P-110, type DE, class 2, installed at opposite ends, so that an covert attempt to penetrate the box will be obvious.

d. If the junction box contains SCI information, it shall meet the requirements detailed in references (b) and (c).

Note: Prior to 1997, it was not necessary to install GENSER SECRET cables so they were inspectable outside of the accredited space, nor in conduit when passing through normally locked spaces. Installations made under previous criteria shall not be reported as a discrepancy.

A.1.1.7.3.2 Cables containing Top Secret/SCI Information Outside an Accredited Secure Space. New installations of cables containing TS/SCI information may be run outside of a space accredited at that level of security only when authorized by DIA/DAL-2A and must meet the requirements defined in references (a) and (b).

A.1.1.7.4 RED and BLACK Conductor Separation. Fiber optic and metallic wire cables containing conductors connected to a RED electrical distribution system may also contain conductors connected to a BLACK electrical system with the following considerations.

A.1.1.7.4.1 Metallic Conductors. RED conductors or pairs of conductors shall be shielded and insulated individually or overall from the BLACK conductors. Cables containing SCI information shall not have any conductors connected to a RED GENSER or BLACK distribution system. RED and BLACK cables may use common wireways. Breakout from the distribution system must be within a space accredited to the highest classification level of data within the distribution system or within a breakout box in an inspectable location. See A.1.1.7.3 for more guidance. This paragraph is not applicable to BLACK signal/power conductors connected to an RF transmitter, with the exception of plain/cipher secure voice.

A.1.1.7.4.2 Fiber-optic Conductors. Fiber optic bundles may contain both RED and BLACK conductors if the RED and BLACK conductors are separated by an opaque dielectric sheath. Breakout from the bundle must be within a space accredited to the highest classification level of data within the bundle or within a breakout box in an inspectable location. See A.1.1.7.3 for more guidance.

A.1.1.7.4.3 Shared Metallic Wire cable Junction Boxes and Cable Entrance Boxes. Junction boxes may be used as an intermediate connection point for metallic wire cables containing both RED low level (for example, single audio systems) and BLACK circuits. If they are external to an area accredited for the highest level of information carried, see A.1.1.7.3. Cable entrance boxes containing both RED and BLACK circuits may be used for fanning cable conductors and their shields for an orderly penetration of a group of individual wire pairs into equipments (such as secure voice matrix switches). Cables and conductors of a shared junction box or cable entrance box shall conform to the following:

- a. The lay of a twisted pair shall be retained to the point of connection on the terminal strip.
- b. The shield over a twisted pair shall be retained within the box to the point of connection on the terminal strip. The length of unshielded conductor at the point of termination shall be kept as short as practical. Where an existing box has the shield(s) bonded to ground at or near the point of cable entry, a sleeve-braid shield shall be added over the wire pairs and bonded to ground at each end. If the twist has been removed from the wire pair, it shall be restored prior to adding the shields.
- c. Within a junction box, the shield shall be bonded to ground at the terminal strip (see B.1.2.6.16). Within a cable entrance box, the shield shall be bonded to ground in the equipment being served by the cable entrance box in accordance with the methods of B.1.2.6.16.
- d. Conductors within a junction box shall be as short as practical yet be long enough to reach any terminal connection.

A.1.1.7.5 Conductive Paths for Metallic Wire Signal and Control Lines. RED metallic wire signal and control lines shall be composed of twisted pairs of conductors, and shall not use the shield, armor or the ship hull for the electrical return path. As an exception, the shield on coaxial cables shall be used as the electrical return path if required for system operation (i.e., RED video signals to a CCTV or computer monitor).

A.1.1.7.6 Applications of Optical Cable Systems. Optical cables can be used in RED and BLACK signal distribution systems to prevent the unintended transmission of TEMPEST signals outside the inspectable space. See MIL-STD-188-111 (reference (i)) for interoperability and performance standards of optical cable systems for military application.

A.1.1.7.6.1 Fiber-Optic Cable Strength Members or Shielding. A strength member included in some multifiber cables can be made of steel or other metal. Such a metal component in the cable could be a fortuitous conductor. Therefore, treat fiber optic cables with metal strength members and/or conductive shielding (cladding) the same as metal lines and separate in accordance with paragraph A.1.1.1.

A.1.1.8 Secure Voice.

A.1.1.8.1 Objective. The overall secure voice system shall be accorded the standards for a plain/cipher (p/c) secure voice subsystem, unless otherwise specified herein. The secure voice system shall be isolated from all other systems as specified herein.

A.1.1.8.2 Line and Signal Levels. The RED analog voice signal line shall be a 600-ohm balanced system. The audio level shall not exceed 0 dB as referred to 1 milliwatt (dBm), except in the signal line between an audio amplifier and a loudspeaker.

A.1.1.8.3 Signal Processing Levels. When the secure voice system is capable of p/c operation, the RED signal level (see A.1.1.7.2.) shall be not greater than the BLACK signal level.

A.1.1.8.4 Multichannel Magnetic Tape Recorders in p/c Secure Voice. A multichannel magnetic tape recorder installed in a surface ship and used to record p/c secure voice communication channels shall:

- a. Use individually shielded twisted pair cables for audio input lines.
- b. Be located not less than 3 feet from BLACK signal processors and 10 feet from RF transmitters.

Note: Prior to 1997, the separation requirement was six feet from RF transmitters and any BLACK path to transmitters, such as controls, patch panels, switchboards, etc.. Installations made under previous criteria shall not be reported as a discrepancy.

A.1.1.9 Data Patching Equipment. RED and BLACK jack fields shall not be installed in the same patch panel. Separate RED and BLACK patch panels in accordance with A.1.1.1.

A.1.1.10 Bonding. Cryptographic equipment, RED electrical processing equipment, RED junction and terminal boxes, RED fiber optic converter/transducer units, RED cable shields (and armor, if applicable), BLACK cable shields installed on transmitter lines in lieu of physical separation per A.1.1.1, and BLACK metallic transmitters and transmitter control units addressed in paragraph A.1.1.1, shall be bonded to ground. Shields requiring bonding shall be taken to ground at both ends of the cable. Spare conductors of RED cables, which leave the space, shall be taken to ground at both ends of the cable.

A.1.1.11 BLACK Television Equipment Connected Directly to an Antenna or Shore Cable System. BLACK television sets connected directly to an antenna or a commercial shore cable system located in the same compartment with RED data processing equipment shall meet the RED/BLACK physical separation requirements for BLACK processing equipment described in paragraph A.1.1.1

THIS PAGE INTENTIONALLY BLANK

APPENDIX B
INSTALLATION GUIDANCE, AMPLYING INFORMATION AND ILLUSTRATIONS

B.1.0 SCOPE.

B.1.1 Scope. This appendix contains amplifying guidance and illustrations covering installation and inspection criteria for shipboard secure electrical information processing systems. The paragraphs and illustrations contained in this appendix depict and explain the implementation installation criteria cited in section A.1.1.

B.1.2 DETAILED REQUIREMENTS

B.1.2.1 Support of Primary TEMPEST-Related Installation Standards. The detailed paragraphs herein support the TEMPEST related installation requirements of section A.1.1 in identifying the methods and procedures that fulfill the basic TEMPEST related requirement.

B.1.2.2 RED and BLACK Signal and Control Line Interfaces. Equipments having a RED and BLACK signal and/or control line interface are equipments which have one or more connection(s) to a RED system (RED signal lines or RED control lines, or both) and one or more connection(s) to a BLACK system (BLACK signal lines or BLACK control lines, or both). In a p/c secure voice application, any equipment which have two or more p/c secure voice signal (transmit and receive) inputs or outputs is a RED and BLACK signal and control line interface. Equipment having a RED and BLACK signal and/or control line interface shall be limited to the following categories:

- a. Isolation devices having prior TEMPEST approval.
- b. Isolation devices not having TEMPEST approval shall conform with the following minimum port-to-port isolation:
 - (1) 100 dB over the baseband audio frequency range between 0.3 and 15 kHz.
 - (2) 80 dB over the baseband video frequency range up to 5 MHz.
 - (3) 60 dB over the frequency range up to ten times the basic data rate (10Rd) of the digital signal(s) processed.
- c. Cryptographic equipment, as an NSA-approved item, does not require specific TEMPEST approval. Such equipment shall be bonded in accordance with paragraph B.1.2.6.13
- d. Processing equipment shared between RED and BLACK signal distribution systems shall have the distribution systems isolated from each other with a TEMPEST approved isolation device (for example, SA-734/SG, SA-2371/SG, SA-2626/BR, SB-1299/USQ-20 and SB-3372/UG).

e. Equipment in a. or c., installed for the purpose of technical or operational evaluation or both, do not require prior TEMPEST approval for the period of the evaluation.

f. RED processing equipment may receive signal or control information directly from a BLACK navigation system (for example, own ship speed, own ship head, roll, pitch, omega, loran, GPS and wind direction and speed).

g. RED processing equipment may directly interface a time-code generator or display system. Frequency standard distribution systems shall only interface a RED system via a time-code generator or display system or via an approved isolation device.

h. RED processing equipment may directly interface a BLACK AN/SLA-10() Blanker-Video Mixer Group.

i. Junction boxes installed as specified in A.1.1.7.4.3.

j. Combined radio and secure systems shall be installed in boats and craft in accordance with the following:

(1) Where a radio transceiver and secure voice processing equipment share common circuitry, such as power supplies, by system design, such system shall be TEMPEST approved prior to installation.

(2) Where a unit of a radio transmitter performs the function of switching between plain and cipher voice, the total system of radio and RED processing equipment shall be TEMPEST approved prior to installation.

NOTE: Not an inspection item. This is a design information item

B.1.2.3 Approved Equipment. Communication, electronic processing (RED and BLACK) and ancillary equipment installed in secure spaces shall be of a type included in approved NAVSEA drawings or documents. Commercial off-the-shelf (COTS) equipments may be installed when directed by the cognizant authority (NAVSEA, etc.).

B.1.2.3.1 Cryptographic Equipment Cables. The cables supplied with cryptographic equipment are often of specific length, wire gauge or shielding characteristics, and are part of the total system design. The fully assembled NSA issued cables shall not be modified or altered in length, unless promulgated as an authorized change.

B.1.2.3.2 Electronic Equipment Cables. Some of the interconnecting cables supplied with RED processing equipment may be unique in construction and designed to enhance its TEMPEST characteristics. Such cables shall not be modified unless the installation control drawings or technical manuals specify modification.

B.1.2.4 Radio Transmitting Equipment. Radio transmitters and other devices used for the transmission of electromagnetic energy through space may be installed in or adjacent to secure spaces. This allows the transmitter room to be installed adjacent to and to be entered from the communications center or other secure space. See paragraph A.1.1.1 for physical separation requirements and shielded cable options.

B.1.2.4.1 Radio Set Controls. Radio set control units, or other devices providing remote control or indicator circuits (for example, C-1004/SG, C-9899/WSC-3) may be mounted on any RED or BLACK processing equipment having a metal cabinet unless specifically prohibited in this enclosure.

B.1.2.5 Approved Cables. RED metallic wire shielded cables shall meet the applicable requirements of MIL-C-17 (reference (k)), MIL-C-915 (reference (l)), MIL-C-24640 (reference (n)), or MIL-C-24643 (reference (o)).

B.1.2.6 Bonding Methods. Within the electrical perimeter barrier of a secure space, for RED equipment and cable, the various parts, units and assemblies of an electrical processing distribution system shall be bonded to ground as specified in the following paragraphs or by any appropriate method in MIL-STD-1310() (reference (j)). In nonmetallic hull ships, the third wire or safety ground shall be an acceptable substitute for any bond strap specified herein.

B.1.2.6.1 Bonding Classes. Bonding methods shall be of the following classes:

a. Class A. A bond achieved by joining two metallic items or surfaces through the process of welding or brazing.

b. Class B. A bond inherent in the installation of an item or equipment by mounting hardware or other areas of bare or other properly prepared metal-to-metal contact.

c. Class C. A bond achieved by bridging two metallic surfaces with a metallic bond strap.

B.1.2.6.2 Class B bonds. When a class B bond is specified as the method of bonding an equipment, box or panel to ground, all available mounting holes provided in the equipment shall be used. The diameter of the mounting bolts, nuts, and washers shall conform to the mounting holes with normal tolerances. When holes must be drilled, the minimum diameter shall be for 0.25-inch hardware unless otherwise specified. Bolts, nuts and washers shall be zinc-plated steel or CRES Series 300. Plastic or nylon lock nuts may be substituted for split lock washers if desired; however, if the lock nut is removed for any reason, it shall be discarded and replaced with a new lock nut. Paint, grease, lacquer, and other resistive materials shall be removed from the surface contact

area(s) prior to bonding. Class 3 chemical coatings, i.e. anodizing, applied in accordance with MIL-C-5541 (reference (m)) are conductive coatings and shall not be removed. Abrasives used shall be of the type which produce a clean, smooth surface. The cleaned metal surfaces and threaded hardware shall be coated with an antiseize compound conforming to MIL-T-22361 (reference (p)) prior to mounting the equipment.

NOTE: Prior to 1993, the use of antiseize compound on a class B bond was only a recommendation. Equipment installed under previous criteria without using antiseize compound shall not be reported as a discrepancy.

B.1.2.6.3 Flexible Bond Strap Fabrication. Flexible bond strap shall be fabricated from 1-inch flat braided wire, using lugs fabricated from 0.840-inch diameter copper tubing, flat copper stock folded over the braid or commercial copper lugs with a barrel large enough to accommodate the 1-inch braid without trimming. The length shall be as required, and as short as practical. Drill mounting holes for 5/16-inch hardware with normal tolerances. Bolts, nuts, and washers shall be 5/16-inch hardware and zinc plated or CRES Series 300. Plastic or nylon lock nuts may be substituted for split lock washers if desired; however, if the lock nut is removed for any reason, it shall be discarded and replaced with a new lock nut. See Figure B-2 for typical bond strap fabrication. Flexible bond straps will only be used to bond resilient mounted equipment or cabinets (see B.1.2.6.11) and slide-mounted equipment (see B.1.2.6.12).

B.1.2.6.4 Solid Bond Strap Fabrication. Solid bond strap material shall be copper, at least 0.020-inch thick, and at least 3/4-inch wide. The length of the bond strap shall be not greater than five times the width and shall be as short as practical (see figure B-3). Punch or cut out mounting holes for 5/16-inch hardware with normal tolerances. After installation, the bond strap may be painted to match the surrounding area. Bolts, nuts, and washers shall be 5/16-inch hardware and zinc-plated steel or CRES Series 300. Plastic or nylon lock nuts may be substituted for split lock washers if desired; however, if the lock nut is removed for any reason, it shall be discarded and replaced with a new lock nut.

B.1.2.6.5 Preparation for use of Bond Straps.

a. Bond straps shall be installed in locations that permit rapid visual inspection and replacement. Bonds shall in no way interfere with internal parts of the equipment or the movement of resilient mounts. Ground studs built into enclosures shall be utilized in preference to drilling a new hole, provided the ground stud location on the enclosure will not increase the length of the bond strap beyond normal tolerance. Grease, paint, lacquer, and other resistive materials shall be removed from at least 1-1/2 times the bonding surface contact area.

b. Class 3 chemical coatings, i.e. anodizing, applied in accordance with MIL-C-5541 (reference (m)) are conductive coatings and shall not be removed. Abrasives

used shall be of the type that produces a clean, smooth surface. The cleaned metallic surface and threaded hardware shall be coated with an antiseize compound, conforming to MIL-T-22361 (reference (p)), prior to the installation of the bond strap.

NOTE: Prior to 1983, the use of antiseize compound on a class C bond was only a recommendation. Equipment installed under previous criteria without using antiseize compound shall not be reported as a discrepancy.

B.1.2.6.6 Assembled Equipment Units. Except where specific equipment bonding requirements are specified herein, assembled equipment (for example, the C-10315() manual single audio system switch matrix) shall be considered to have all physical and electrical units properly bonded to each other based on the requirement of the applicable equipment specification. This includes hinged panels, retractable drawer assemblies, and other movable units or parts provided within an assembled equipment for ease of installation or maintenance.

B.1.2.6.7 Fabricated Equipment Units. The main enclosure of fabricated equipment (for example, locally fabricated, engineered or installed COTS equipment configurations) containing assembled equipment shall be bonded to ground with class A, B, or C bonds as appropriate. Individual units shall be bonded to ground via the main enclosure with class B or C bonds, as appropriate.

B.1.2.6.8 Electronic Equipment Cabinets. Electronic equipment cabinets (for example CY-4516()/S) shall be bonded to ground with class A, B, or C bonds. Conductive Class 3 chemical coatings (i.e., anodizing) applied in accordance with MIL-C-5541 (reference (m)) are conductive coatings and shall not be removed. Conductive paint applied in accordance with MIL-P-21035 and conductive caulk should be used when installing equipment racks, cabinets and consoles on their foundations with a Class B bond. Conductive paint applied in accordance with this paragraph shall be certified in writing at the time of application. A copy of this written certification shall be placed in the ship's CLIPS file. This document shall certify:

- a. That the paint used meets the requirements of Military Specification MIL-P-21035.
- b. That the surface of the conductive material, i.e., metal, etc. to which the paint has been applied has been properly prepared and was completely free of all foreign material prior to application of the conductive paint.
- c. That the paint was properly mixed by volume and applied with sufficient coats to insure conductivity as well as prevent corrosion.
- d. That all attachment hardware fully meets the current requirements of this standard.

e. That, when tested for resistance between the secondary structure (rack, cabinet or console) and the primary structure (ship's hull), there shall be a resistance of no more than 300 milliohms.

B.1.2.6.9 Equipment Mounted in Electronic Equipment Cabinets. Equipment rack mounted in electronic equipment cabinets may be considered bonded to ground with the front-panel mounting hardware. Surface preparation shall be in accordance with B.1.2.6.2. Cryptographic equipment has its own bonding and grounding requirements.

B.1.2.6.10 Bonding of Non-Resilient Mounted Equipment. Non-resilient mounted equipment in their original cabinets shall be bonded to ground with a class B bond or class C bond strap. For cryptographic equipment bonding, see B.1.2.6.13.

B.1.2.6.11 Bonding of Resilient Mounted Equipment or Cabinets. Resilient mounted equipment or cabinets shall be bonded to ground with a class C bond strap. Figure B-5 of this appendix illustrates typical and specific bonding methods for resilient mounted equipment. Flexible bond straps may be used on equipment having resilient mounts that allow multidirectional excursions that may damage solid class C bond straps.

B.1.2.6.12 Bonding of Equipment Mounted on Slide Foundations.

a. Equipment mounted on sliding foundations (for example, slide rack-mounted shelves) shall be bonded to the sliding foundations as specified for each category of equipment in B.1.2.6.10, B.1.2.6.11, and B.1.2.6.13. A class B bond may be used to bond the sliding foundation to the solid foundation as specified in B.1.2.6.9, if the slide is secured to the rack with hex-head bolts or standard slotted screws, and surface preparation is in accordance with B.1.2.6.2. If the slide is secured with fasteners meant to be tightened with fingers rather than tools, the slide foundation shall be class C bonded to the solid foundation.

b. An alternative method to the above is to bond the equipment directly to the solid foundation with a solid or flexible class C bond strap, as appropriate.

B.1.2.6.13 Bonding of Cryptographic Equipment. Cryptographic equipment and cryptographic ancillary units (for example, TSEC nomenclature equipment) shall be bonded to ground with a class C bond strap, except as otherwise specified herein. A new hole shall not be drilled in cryptographic equipment or cabinet enclosure, except where the equipment has a separate cable entry section. Existing mounting holes may be enlarged to accommodate standard mounting hardware. The following are typical bonding arrangements for cryptographic equipment:

a. TSEC/KI-1. The designated mount, MT-4580/U or MT-4667/U, provides the necessary bond between the KIT-1(V)/TSEC and a foundation. The designated mount, MT-3950/U, MT-4580/U or MT-4667/U provides the necessary bond between the KIR-1(V)/TSEC and foundation. The designated mounts shall be bonded to ground with a class B bond or a class C bond strap.

b. TSEC/KG-40A. The designated mount, MT-4417/S, provides the necessary bond between the TSEC/KG-40A and a foundation. The designated mount shall be bonded to ground with a class C bond strap installed between the ground stud provided on the mount and the foundation.

c. TSEC/KG-44. The TSEC/KG-44 mounted in the OL-350/SMQ-11 has an inherent bond to ground and does not require additional bonding. The AN/SMQ-11() shall be bonded to ground with a class C bond strap.

d. TSEC/KG-45. The TSEC/KG-45 mounted in the electronic cabinet containing the OR-209/SRQ-4 has an inherent bond to ground, and does not require additional bonding.

e. KGX-40/TSEC. The KGX-40/TSEC shall be bonded to its mount with a class B bond. The mount shall be bonded to ground with a class B bond or a class C bond strap.

f. TSEC/KY-58. The TSEC/KY-58 is bonded to the HYX-58/TSEC via the mechanical fasteners. The HYX-58/TSEC mounted in the MT-4841(V)/U is bonded to that unit with the internal copper fingered leaf springs, and does not require additional bonding.

g. MT-4841(V)/U. Units mounted in MT-4841(V)/U (except the TSEC/KY-75 and AN/USC-43 (ANDVT)) have an inherent bond to the MT-4841(V)/U. The MT-4841(V)/U may be class B bonded if the rear mounting flanges are bolted to ground; otherwise, the MT-4841(V)/U shall be bonded to ground with a class C bond strap.

h. TSEC/KG-59 and KOK-6/TSEC. The TSEC/KG-59 and KOK-6/TSEC shall be bonded to ground with a class B bond or a class C bond solid strap.

i. TSEC/KG-84. The standard TSEC/KG-84 installation using the MT-4841(V)/U Ship Shelf has an inherent class B bond to the MT-4841(V)/U. The nonstandard installation without the MT-4841(V)/U shall be class C bonded using the TSEC/KG-84 grounding plate kit.

j. TSEC/KGV-11. The TSEC/KGV-11 mounted in the OK-618()/USC-38, part of the EHF SATCOM Communications Equipment Group (CEG), or in the OK-454(V)/WSC DAMA equipment, has an inherent bond to the electrical equipment cabinet. The electrical equipment cabinet shall be bonded to ground with a class B bond or a class C solid bond strap.

k. TSEC/KWR-46. The TSEC/KWR-46 has an inherent bond to the HNF-1/TSEC through the mounting hardware. The HNF- 1/TSEC is bonded to the mounting shelf with a solid class C bond strap.

l. TSEC/KYV-5. The TSEC/KYV-5 has an inherent class B bond to the AN/USC-43(V) Basic Terminal Unit (BTU). The BTU shall be bonded to ground with a class C solid bond strap between the ground stud on the BTU and the foundation.

B.1.2.6.14 Bonding of Isolation Devices and Filters. Isolation devices and telephone and signal line filters shall be bonded to ground with class B bonds or class C bond straps.

B.1.2.6.15 Bonding of RED Terminal Boxes or Junction Boxes. Terminal boxes, junction boxes, and switch boxes which are part of a RED electrical processing system shall be bonded to ground with a class B bond or class C bond strap.

B.1.2.6.16 Bonding of Shields and Armor on Cables. RED cables and BLACK cables optionally installed per A.1.1.1 shall have the shields (and armor, if applicable) bonded to ground at both ends of the cable in accordance with the following:

a. Cable shields terminating on barrier terminal strips as specified in A.1.1.7.4.3 shall be bonded to ground within the enclosure at the terminal strip. (see Figure B-1)

b. Cable shields not covered by a. above shall be bonded to ground by any of the following:

(1) At a terminal strip within an enclosure.

(2) At the point of entry within an enclosure. If shields are connected to lugs, they shall be limited to six per lug. The maximum number of lugs that may be stacked on a single bonding screw or stud is four. If more than one shield is connected to a bonding lug, it shall be soldered into the lug in addition to crimping.

(3) Via a standard threaded or bayonet ("quick disconnect") cable plug connector which shall provide shield bonding via the connector hardware.

Note: The strain relief on the standard MS connector will not provide a positive connection to the metallic body of the connector, and shall not be used as the point to ground the shield. Wherever possible, the shield shall be connected to a pin within the connector which will connect with ground within the equipment.

c. Armor shall be bonded to ground at the point of entry to an enclosure.

d. RED cables requiring an ungrounded shield at one end of the cable in conformance with manufacturer's specifications may be installed as recommended by the manufacturer. If both ends of the cable will not have the shield taken to ground, approval by the cognizant CTTA should be obtained prior to installation.

NOTE: If only one end of a cable has its shield bonded not per the manufacturers specifications, and the ship's TEMPEST file does not contain documentation that prior approval from the CTTA has been obtained, the inspector shall provide all relevant details (such as system/equipment involved, signaling in the cable, separation distances from unshielded cables to RF transmitters, the manufacturer of the equipment, and the source of the manufacturer's recommendation, as minimum information) in the body of the report, but shall not list the item as a discrepancy that must be corrected.

e. The methods of bonding shields and armor shall be in accordance with one or more of the following:

(1) Any of the methods of MIL-STD-1310 (reference (j)), except cables covered by A.1.1.7.3.1.

(2) The use of ground ring kits and connectors designed to provide shield bonding via the connector hardware, including coaxial and triaxial.

(3) Other methods having prior approval which will be based on submitted drawings or sketches illustrating the methods proposed.

B.1.2.6.17 Bonding of Spare & Unused Metallic Wire Cable Conductors & Shields. Unused or spare conductors and shields (and armor, if applicable) of RED metallic wire cables which penetrate the electrical perimeter barrier of a secure space shall be bonded to ground at both ends. This requirement does not apply to conductors in Automated Single Audio System cables identified in Note 29 in NAVELEX Drawing 28687-0125013 Rev F. Unused or spare conductors shall have a length sufficient to be connected to any of the terminations.

B.1.2.6.18 Bonding of Stand-Alone Desktop Computer Equipment. Desktop and stand-alone personal, mini-, and micro-computers may be bonded to ground via the third-wire or safety ground if an appropriate ground stud is not available on the chassis or equipment cabinet.

B.1.2.6.19 Bonding of RED CCTV Equipment. RED CCTV equipment shall be bonded to ground using any one of the following methods which are most practical and in conformance with the other requirements of the CCTV system:

a. A class B bond between the equipment chassis or metallic cabinet enclosure and ground-potential support frame or foundation.

b. A class C bond strap for equipment in a non-metallic enclosure. The bond strap shall be connected between the equipment chassis and ground.

c. As prescribed by the manufacturer.

d. For portable equipment only (i.e., a camera on a dolly) via the third wire or safety ground in the power cable or a ground conductor in a control cable. This method may also be used for CCTV equipment that cannot be easily class B or C.

B.1.2.6.20 Bonding of BLACK processing & non-processing equipment & devices. Electrical lighting fixtures, BLACK processing equipment (with the exception of BLACK processors installed under the options of appendix (A), paragraph 1.1.1) and other electrical non- processing equipment and devices in secure spaces need not have bonding applied as a TEMPEST requirement.

B.1.2.6.21 Removal of Armor. The armor may be stripped from shielded cable as an alternative to bonding the armor to ground.

B.1.2.7 Electrical Perimeter Barrier. An electrical perimeter barrier shall enclose that part of the secure processing center that processes RED electrical information. This requirement is not applicable to nonmetallic hull ships.

B.1.2.8 Temporary Installations of Red Processing Equipment. Type commander approved temporary installations of RED processing equipment shall conform to the minimum TEMPEST-related configuration control criteria set forth below. A temporary installation shall not exceed 9 months. Prior to or at the end of the 9-month period, the equipment shall be removed, or reinstalled in conformance with A.1.1 and the guidance provided in this document. The minimum installation criteria is as follows:

a. The RED and BLACK signal distribution systems shall be physically separated and electrically interfaced as specified in A.1.1.1 and B.1.2.2.

b. RED metallic wire cable shall be shielded. The shield shall be bonded to ground at each end of the cable. (See paragraphs A.1.1.7.1 and B.1.2.6.17 for exceptions.)

c. The RED equipment shall be bonded to ground with a class B bond or a class C bond strap.

d. Additional criteria may be imposed as required on a case-by-case basis. The Installation Agency shall conduct an inspection immediately after the installation is completed. The Visual TEMPEST Inspection (VTI) report shall note that the installation is temporary and that the inspection of the temporary installation was conducted as specified herein.

B.1.2.9 TEMPEST Installation Criteria Illustrations. The following illustrations may be used to assist in the planning, design and inspection of secure electrical information processing systems.

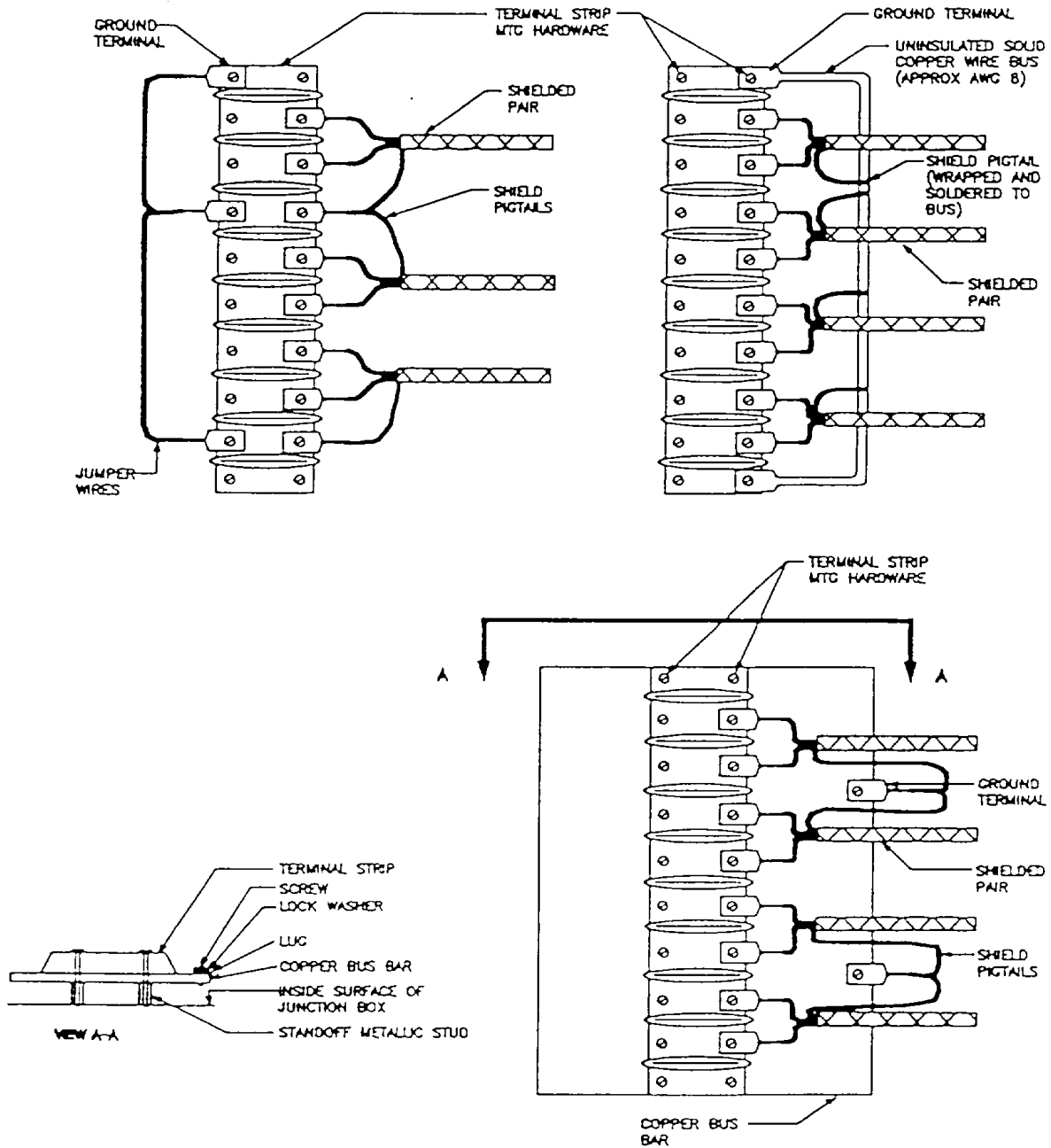
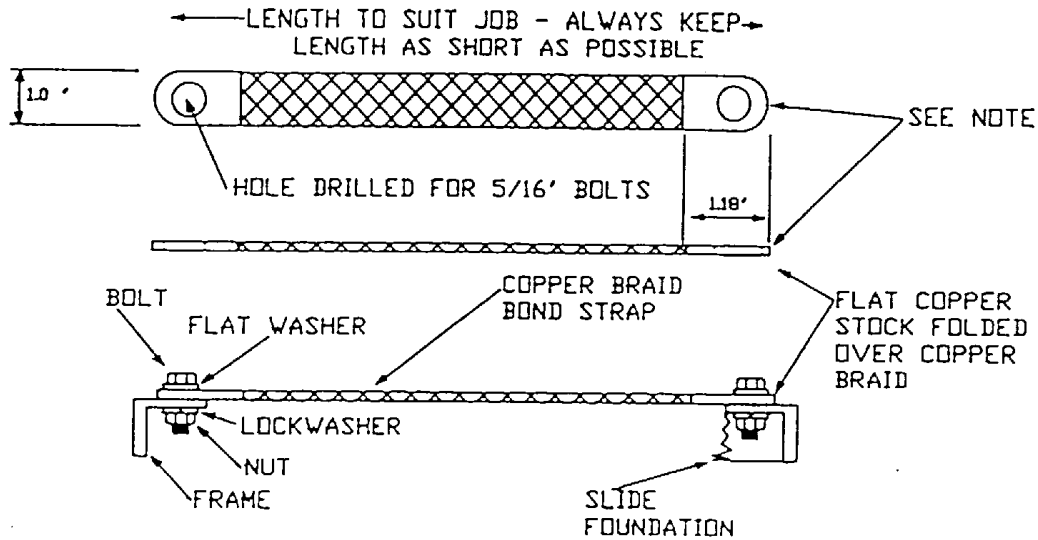

FIGURE B-1. TERMINAL STRIP SHIELD GROUNDING



REV. 3/75

LIST OF MATERIAL			
ITEM NO.	PART	SPECIFICATION	NOTE
1	BRAID WIRE, FLAT	00-B-575	1, 5
2	FLAT COPPER STOCK	ASTM B 152	2, 3 4, 5 6

NOTES:

1. TYPE IV BOND STRAP BRAID MATERIAL SHALL BE FLAT COPPER BRAID IN ACCORDANCE WITH 00-B-575.
2. TYPE IV BOND STRAP END TERMINALS SHALL BE IN ACCORDANCE WITH ASTM B 152.
3. END TERMINALS SHALL BE 1.18 INCHES LONG BY 2.0 INCHES WIDE BEFORE BENDING.
4. END TERMINALS SHALL BE HOT TINNED DIPPED AND SHALL HAVE A COATING OF SOLDER ON ONE SIDE. EACH TERMINAL SHALL BE BENT 180 DEGREES WIDTHWISE, TO FIT THE BRAID, USING A .0625 INCH METAL PLATE AS A BEND TEMPLATE. THE SOLDER COATED SIDE SHALL BE ON THE INSIDE OF THE BEND.
5. BRAID MATERIAL SHALL BE FLUX COATED 1.0 INCHES ON EACH END. END TERMINALS SHALL BE HEATED AND COMPRESSED ONTO THE BRAID ENSURING GOOD SOLDER FLOW.
6. HOLES SHALL BE PUNCHED IN EACH END AFTER END TERMINAL INSTALLATION.
7. LENGTH (L) MAY BE SPECIFIED IN NON-STANDARD SIZES.
8. ALL DIMENSIONS ARE IN INCHES.

FIGURE B-2. FLEXIBLE BOND STRAP FABRICATION AND INSTALLATION

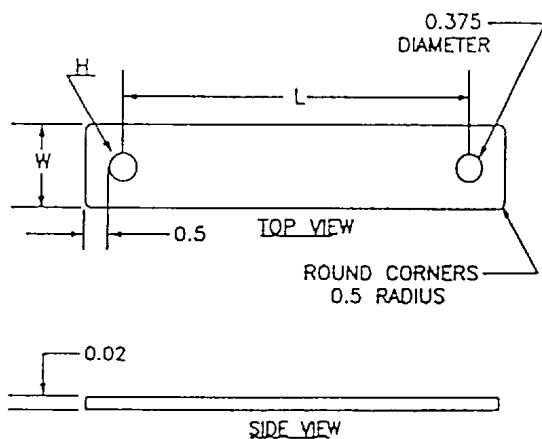

LIST OF MATERIAL			
ITEM NO.	PART	SPECIFICATION	NOTE
1	FLAT CRES STOCK	QQ-P-35	1, 2, 3
2	FLAT COPPER STOCK	ASTM B 152	1, 2, 3

NOTES:

1. TYPE III BOND STRAP MATERIAL SHALL BE FLAT COPPER IN ACCORDANCE WITH ASTM B 152.
2. LENGTH (L), WIDTH (W) AND HOLE DIAMETER (H) MAY BE SPECIFIED IN NON-STANDARD SIZES PROVIDED (L) IS NO MORE THAN FIVE TIMES (W) AND END TO END RESISTANCE DOES NOT EXCEED 0.1 OHM DC RESISTANCE.
3. ALL DIMENSIONS ARE IN INCHES.

STANDARD SIZES			
STANDARD SIZE CODE	L (LENGTH)	W (WIDTH)	H (HOLE DIAMETER)
A	3.0	1.0	0.375
B	6.0	1.5	0.375
C	9.0	2.0	0.375
D	12.5	2.5	0.375

FIGURE B-3. SOLID BOND STRAP FABRICATION DETAILS

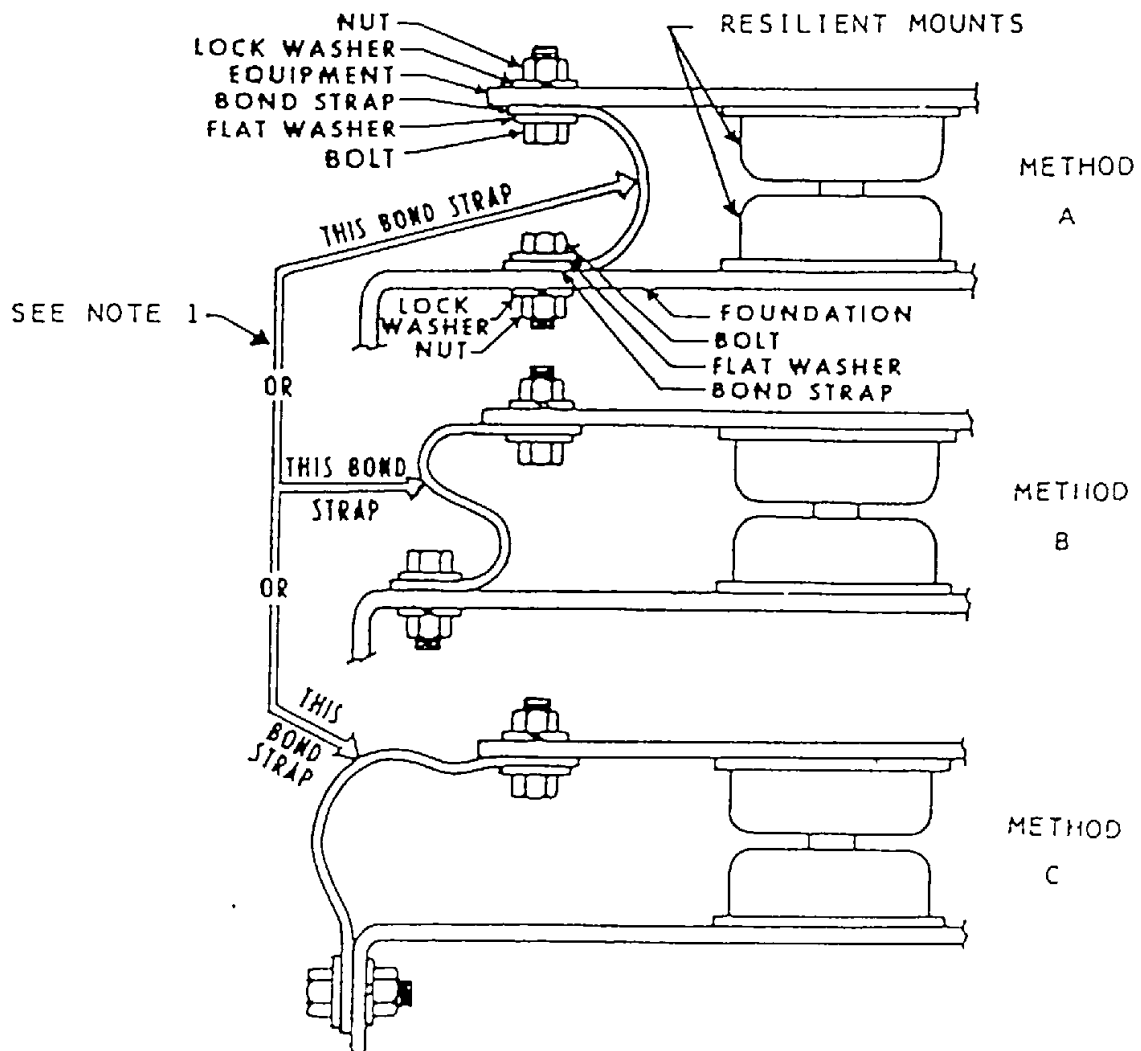

NOTE: ORDER OF PREFERENCE:
 METHOD A
 METHOD B
 METHOD C

FIGURE B-4. BONDING OF RESILIENT MOUNTED EQUIPMENT

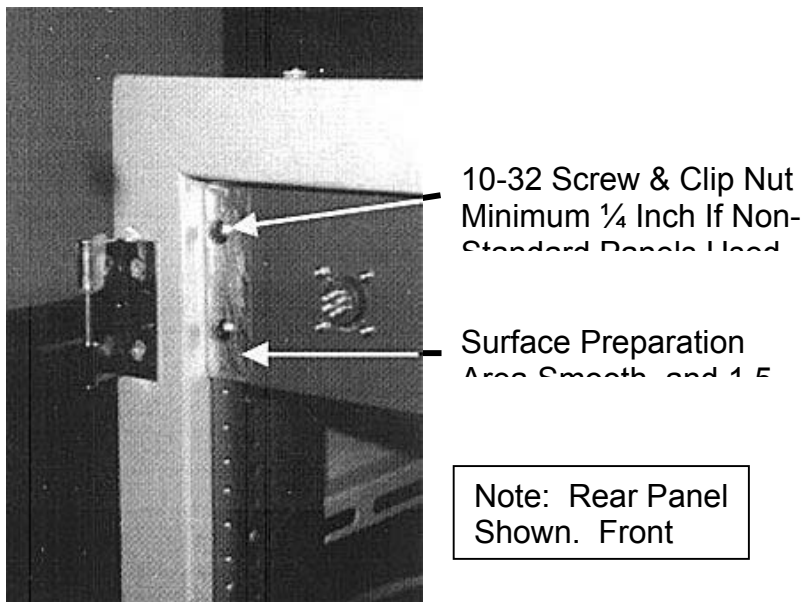
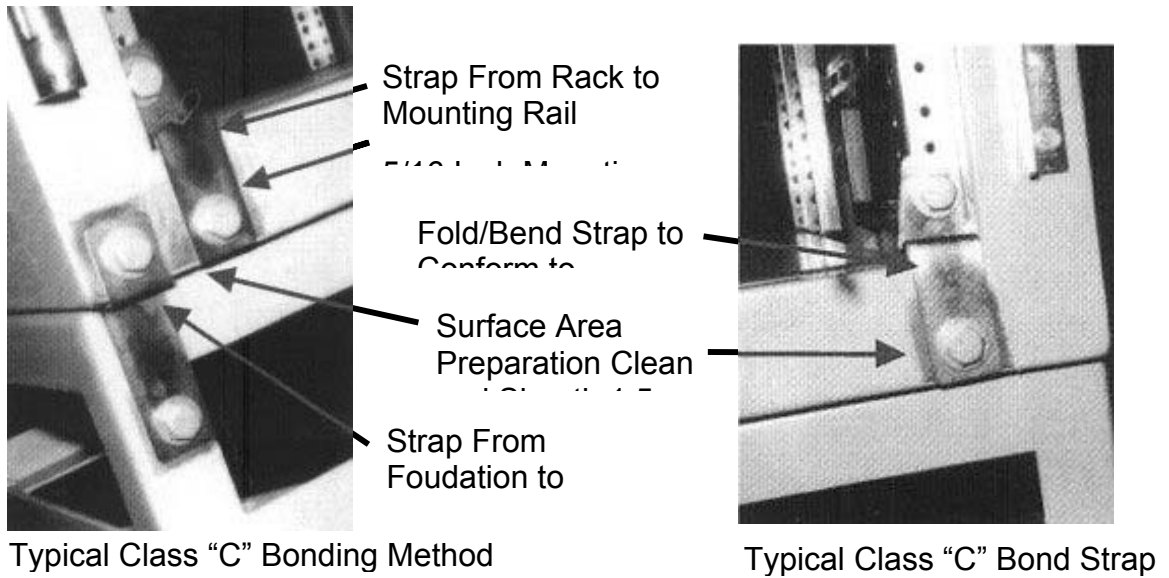
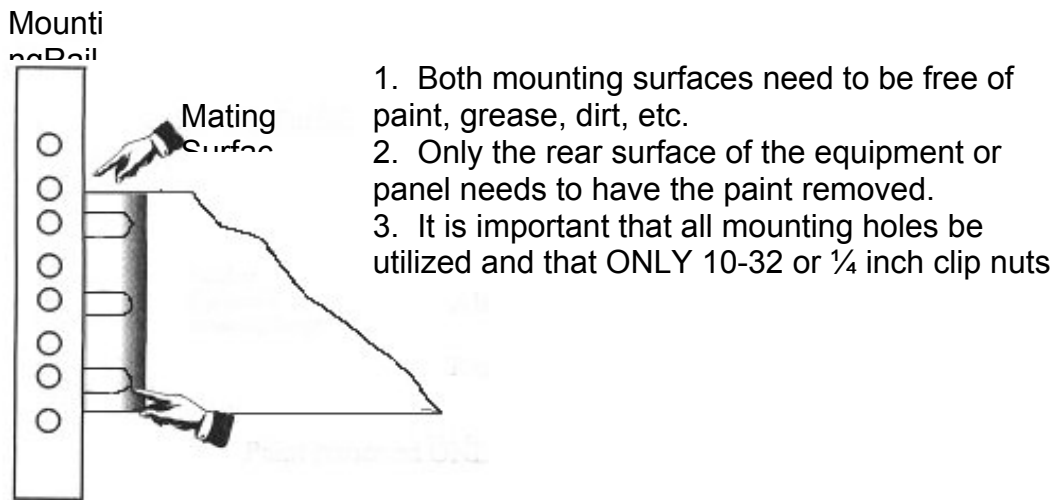
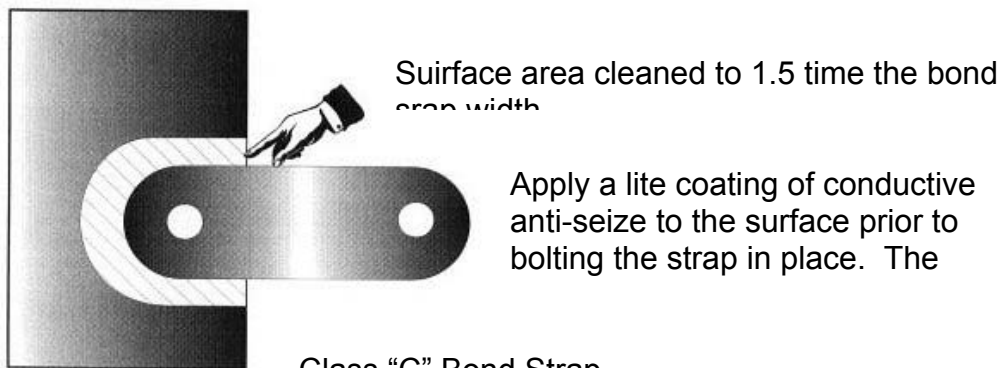

Figure B-5. Typical Equipment Rack Bonding Methods



Class "B" Bond



Class "C" Bond Strap

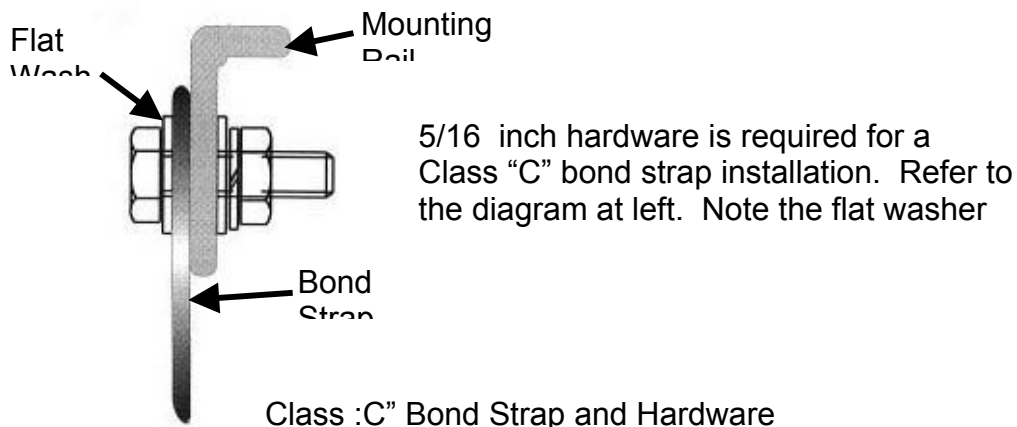

Class "C" Bond Strap and Hardware

Figure B-6. Class "B" and "C" Bonding Procedures

THIS PAGE INTENTIONALLY BLANK