

SECTION 1 -GENERAL

1-1 INTRODUCTION

The information contained in this handbook is based on data obtained from Navy publications such as the Electronics Information Bulletin (EIB), Naval Ship Systems Technical News (Formerly BUSHIPS Journal), and other approved publications. The Communications Handbook is the first of a series of equipment-oriented handbooks which comprise the Electronics Installation and Maintenance Book (EIMB) series.

a. PURPOSE

The purpose of this handbook is to provide Naval personnel with information which will aid in the installation, maintenance, and repair of all types of radio, radio communications, and associated equipments. The material in this handbook is in support of information contained in equipment technical manuals; it provides subordinate policies, and installation and maintenance standards for radio, radio communications, and associated equipments.

b. SCOPE

The Communications Handbook is arranged in five sections: Section 1 - General; Section 2 - Circuit Applications; Section 3 - Field Change Identification Guide (FCIG); Section 4 - Service Notes; and Section 5 - Reference Data.

The material in Section 1 pertains to general information which is not peculiar to one type of communication equipment. The information includes general data on all forms of units used for radio communications, such as amplifiers, antennas, receivers, transmitters, power supplies, remote control units, and so on. A description of the basic principles of operation is given to assist in the application of troubleshooting procedures. In addition, a preliminary outline is given for use in checking the more easily overlooked causes of trouble, and to determine the general area in which the malfunction is located.

Section 2 provides information which describes electronic circuits employed in all types of communications equipment, and will support information contained in equipment technical manuals.

Section 3 provides a current list of field changes together with information enabling technical personnel to determine by inspection the applicable field changes that have been accomplished.

Section 4 contains service notes of specific equipment.

Section 5. This section is under preparation. When completed, it will contain data applicable to communications equipment.

c. TROUBLESHOOTING

The electronics technician is urged to analyze each failure to determine its possible causes before attempting to repair a malfunctioning equipment. This step, which should precede removal of the equipment from its cabinet, includes the following:

1. Equipment operation should be tested in all modes and with the use of all functions to permit the malfunction to be described completely.

2. The performance data obtained should be analyzed, with the use of the equipment schematic or

block diagram, to determine what specific functions, if impaired, would result in the symptoms noted.

3. Finally the specific components, which if failed could result in the impairment of the function noted, should be listed.

Many technicians need no instruction to perform **these** steps, but an outline of the preliminary troubleshooting steps will be useful to the less experienced technician.

More specific troubleshooting procedures are then used to identify the failed component. These, too, might be performed by the experienced technician without specific instructions, but the troubleshooting procedures given will be useful to less experienced technicians. The use of these techniques will save time and money, improved equipment conditions, and improve technical competence.

d. SAFETY

Hazards encountered in servicing electronic equipment and the precautions to be taken against them are covered thoroughly in electronic technicians training courses and the General Handbook (NAVSHIPS 0967-000-0100) of the EIMB series. These sources should be referred to in case of any doubt about safety precautions to be observed in troubleshooting.

Observance of safety precautions will help keep equipment operating, help your career in the Navy, and possibly determine whether you survive. Follow them!

e. RECOMMENDED ADDITIONAL READING

In order to keep this volume within reasonable size, it is not possible to include a wealth of detail that can be valuable to the technician or operator. Therefore it is recommended that the general subject matter covered herein be supplemented with additional publications. Suggested supplementary references include:

Single Sideband Communications NAVSHIPS 0967-307-7010

Emissions and Bandwidth Handbook NAVSHIPS 0967-308-0010

Principles of Telegraphy (Teletypewriter) NAVSHIPS 0967-225-0010

Principles of Modems NAVSHIPS 0967-291-6010

Fundamentals of Single Sideband NAVSHIPS 0967-222-2010

1-2 TYPES OF EMISSIONS

Intelligent operation and servicing of communication equipment depends to a large extent on understanding the types of radio emissions used. AM and FM emissions are tabulated in Table 1-1; the commonly-used AM and FM emissions are described in the following subsections.

a. AMPLITUDE MODULATION

A continuous, unmodulated, fixed-frequency radio signal (A0 emission) carries no modulation which conveys information. A signal must be modulated by another frequency or waveform in order to convey information.

TABLE 1-1. TYPES OF RADIO EMISSIONS

AM	FM	MODULATION
A0	F0	No modulation intended to carry intelligence.
A1	F1	On-off or mark-space keying without the use of a modulating tone.
A2	F2	On-off or mark-space keying of a modulating audio frequency, or of the modulated emission.
A3	F3	Voice-frequency modulating, including simplex AFTS RATT.
A3A		Single-sideband, reduced carrier (SSB).
A3B		Two independent sidebands (ISB).
A3H		Single-sideband, full carrier (compatible SSB).
A3J		Single-sideband, suppressed carrier (SSSC).
A4	F4	Facsimile, with modulation of main carrier directly or by a frequency-modulated subcarrier.
A4A		Facsimile using single-sideband, reduced carrier.
A5	F5	Television.
A5C		Television, vestigial sideband.
	F6	Four-frequency diplex telegraphy (RFCS RATT).
A7		Multi-channel voice-frequency telegraphy (AFTS MUX).
A7A		Multi-channel voice-frequency telegraphy (AFTS MUX) using single-sideband, reduced carrier.
A7B		Multi-channel voice-frequency telegraphy (AFTS MUX) using two independent sidebands.
A7J		Multi-channel voice-frequency telegraphy (AFTS MUX) using single-sideband, suppressed carrier.
A9	F9	Cases not covered by above (e. g., a combination of telephony and telegraphy).
A9B		Combinations using two independent sidebands.

In CW communication (A1 emission) a carrier is present only during key-down intervals, as shown in Figure 1-1. Turning the carrier on and off in accordance with telegraphic characters is a form of amplitude modulation. Manually-keyed CW emission is designated 0.1A1, which means that its bandwidth (resulting from modulation) does not exceed 0.1 kHz. Such an emission requires a higher degree of operator skill to recover the message content, but uses less spectrum space, employs simpler equipment, and is capable of reliable reception over greater distances (or under more adverse conditions) than other types of emission.

A2 emissions (MCW or keyed audio-modulated CW) are those signals which are modulated with a single audio tone. Such emissions are seldom used for communication purposes in this modern age, but are often encountered in radio aids to navigation.

A3 emissions are those which use more than one modulating audio tone to carry one channel of intelligence. Voice or "phone" transmissions use this type of emission. A3 is also used to designate single-channel audio frequency tone shift (AFTS) teletype and some types of multiple-tone remote control

emissions. That is why some transmitters must be in a "voice" or "A3" mode when they are to be amplitude-modulated by an AN/SGC-1A, AN/UCC-1 or other AFTS tele-type terminal unit. Military A3 emissions are normally limited to 6A3 (6 kHz bandwidth) to conserve spectrum, but high-quality AM broadcast emissions may use 16A3 for higher fidelity.

A4 emissions (nominally 5.450A4) are those which transmit picture elements by a slow-scan process. It is commonly called facsimile. By using a slow scan rate, its bandwidth can be confined to 5.450 kHz, a range which can be handled by the same transmitters and receivers used for A3.

A5 emissions are those which transmit picture elements by a fast scan process as in television. The fast scan process calls for bandwidths as great as 6000 kHz (6000A5), which require transmitters and receivers having such a passband capability.

A7 emissions are those which are amplitude-modulated by multiple channels of audio frequency tones, and are commonly called "multiplex." For teletype, A7 consists of multiple audio frequency subcarriers or sidebands which are shifted in frequency in accordance with the keying intelligence.

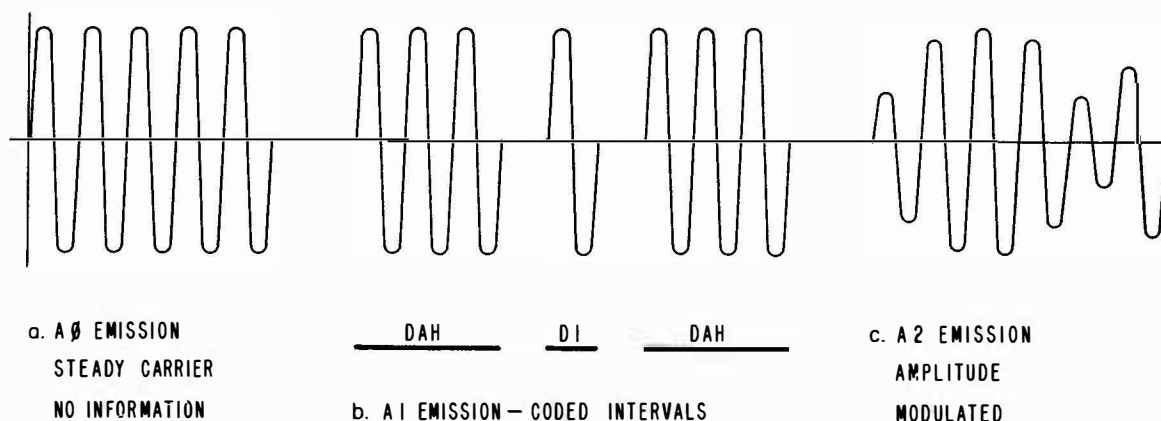

Figure 1-1. RF Waveforms

By international agreement, the various types of emission are assigned the designations given in Table 1-1. A designation may be preceded by a numerical value which indicates its necessary bandwidth in kilohertz.

Optimum communication effectiveness is achieved when received passband matches the bandwidth of the emitted signal. For example, 6A3 voice emission is best received on a receiver having a 6 kHz passband (plus a small fudge-factor for frequency error). A greater receiver passband admits more noise, but no more signal because the signal occupies only 6 kHz in the first place. Therefore a greater receiver passband can only degrade the receiver signal-to-noise ratio. Too little receiver passband will also degrade the received signal because of sideband clipping in the receiver. Many modern receivers have provisions for selecting a bandwidth which will approximately match that of the signal which it is to receive.

Some receivers, particularly UHF, employ a passband greater than that required by modulation sidebands because of difficulty in holding transmitters and receivers on an exact frequency, even with crystal control. Such receivers represent a compromise in which signal-to-noise ratio is traded off against frequency tolerance. The modern trend is toward tightened frequency tolerances which, among other things, permits a reduction of receiver passband and consequent improvement in receiver sensitivity.

(1) Understanding Amplitude Modulation

Having a clear concept of a modulated signal is the first step in understanding what single sideband is all about. The usual description of amplitude-modulated telephony with its "modulation envelopes" and "percentages of modulation" doesn't prepare you for full understanding. The conventional explanation of AM makes it practically impossible to form a mental picture of "suppressed carrier," or "single sideband," or even plain CW. It is hoped that this explanation will present a picture that will make it easy for

you to understand "sideband" relationships and modulation techniques, and consequently the test and adjustment procedures required.

To understand amplitude modulation, you must first know what a CW signal is like. It should be apparent that an unmodulated carrier and a CW signal with the key held down are the same thing, namely, AO emissions. On a paroramic receiver or spectrum analyzer they look the same, and any test you can make of them will give the same result. Furthermore, if they are stable they take up no room in the spectrum. If you tune in such a signal on a receiver with the BFO on, you can hear it over several dial divisions and the receiver input or output meter will give a reading over several dial divisions. But neither of these effects proves that the signal is broad - it only indicates that your receiver doesn't have infinite selectivity. By definition, 4040.000 kHz and 4040.010 kHz are not the same frequency, so they must be different. Actually, they differ by 10 Hz, and a receiver or other device that could separate signals 10Hz apart could separate these two.

All this leads us to the first step in visualizing modulated signals. Any single RF source can be represented by an infinitely-thin vertical line on a plot of amplitude versus frequency. Figure 1-2 is such a representation, except that we had to settle for a finite-thickness line. The frequency can be read from the "Frequency" scale, and the amplitude from the "Amplitude" scale. The taller the line, the greater the amplitude. Don't worry about the units - the frequency scale could be megahertz or even hertz. Your paroramic receiver would show such a picture if it had infinite selectivity. If you had a receiver or frequency-selective voltmeter with such selectivity, its input or output meter would indicate the amplitude at one setting of the tuning knob as you tuned across the frequency range shown, and nothing at any other setting.

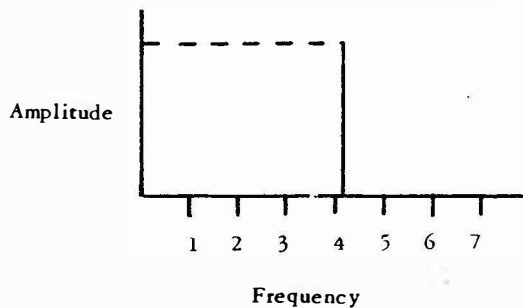

Figure 1-2. A Representation of a Single Radio Frequency

(2) Effect of Two Signals

Suppose now that we wish to transmit intelligence consisting of a simple 1000 Hz tone. One way to do it would be to set up another transmitter on a frequency exactly 1000 Hz removed from the first frequency. It could be higher or lower in frequency - it wouldn't matter so long as the separation was exactly 1000 Hz. The passband of a practical receiver - one that doesn't have infinite selectivity - would admit both signals simultaneously when tuned to or near the correct frequency, and the audio output of the receiver would be the 1000 Hz beat between the two signals. This is hardly a difficult thing to understand; you don't have to operate long in a congested part of the spectrum before you encounter "heterodyne QRM" which is exactly the same thing. Such a signal can be represented as the drawing in Figure 1-3.

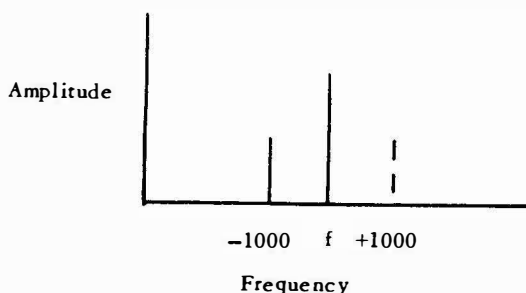

Figure 1-3. Two Radio Signals

In Figure 1-3, the alternative signal which would also give a 1000 Hz beat is shown as a dashed line. If we used three transmitters separated as shown in Figure 1-4, we would still be transmitting 1000 Hz intelligence. All signals removed 1000 Hz from the center frequency give 1000 Hz beats in the receiver, producing audio output of 1000 Hz, the intelligence we are transmitting.

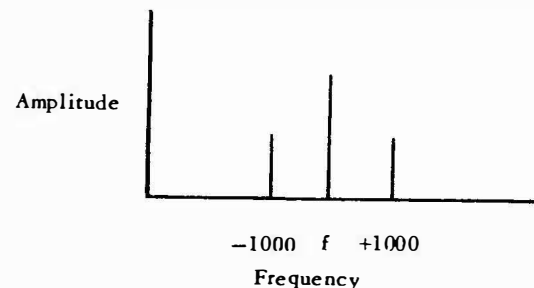

Figure 1-4. A Representation of Two Weak Radio Signals

"Ah, yes," you say, "But what about the 2000 Hz beat between the two outside frequencies? They're separated by 2000 Hz, and you will get a beat between them."

Right you are. Except for one special case where the proper phase relationships exist, this 2000 Hz beat would show up. But the spurious effect is minimized when the center signal is made large in proportion to the other signals. Thus, if we didn't wish to introduce some extraneous or false intelligence at the receiver, we would have to hold the phase relationships exactly right, or keep the amplitude of the center signal large with respect to the others.

Obviously, using three transmitters to transmit this 1000 Hz intelligence is doing things the hard way, and fortunately it isn't necessary. All we have to do at the transmitter, which we will assume is generating a single signal as shown in Figure 1-2, is to beat (or "mix" or "modulate") this signal with a 1000 Hz signal. As in any beating or mixing or modulating or heterodyning process, the output consists of the original two signals, the sum frequencies, and the difference frequencies. Because the original 1000 Hz audio tone isn't R-F, it won't be radiated, but the others will be. The resultant signal is exactly the same as the one we got in Figure 1-4 using three separate transmitters. Being the same signal, it gives the same result in a receiver. And, fortunately, the phase relationships are right to eliminate the spurious 2000 Hz beat mentioned earlier. When you mix signals like this in an AM transmitter, you call it "modulating." But when you do the same thing in a receiver, you call it "demodulating" or "heterodyning" or "detecting" or "beating" or "mixing." Let's use the work "modulate" from now on, remembering that the two signals modulate each other, and that we run into trouble if the "carrier" being modulated isn't large compared to the modulating signal.

At the start, we said that you had to understand the nature of a CW signal to follow this discussion. Let's see why this is so. Suppose, for some reason, that the sole purpose of radio communication was to transmit a 1000 Hz tone. Obviously we could do it in the manners just described, either by setting up three transmitters properly phased, or by modulating the

output from a single transmitter with 1000 Hz of audio. Sooner or later someone would come up with the idea that it isn't necessary to transmit the three signals of Figure 1-4. Instead, you could transmit a single signal as in Figure 1-2 and incorporate a to-be-modulated signal in the receiver. In order to receive only 1000 Hz intelligence, this to-be-modulated signal would be set 1000 Hz higher or lower than the transmitted signal. Every time the transmitter was turned on, we would get the 1000 Hz tone. That is exactly what we do in CW communication circuits. In every respect we would have the same communicating ability that we had when the signal of Figure 1-4 was applied to a receiver which had no to-be-modulated signal.

Note that if the to-be-modulated signal does not maintain an exact 1000 Hz displacement in frequency, a different audio beat will be produced. Or if it is not present at all, we get no tone. For CW operation, the receiving operator selects the tone, and the transmitting operator superimposes further intelligence in the form of a code made up of short and long signals and spaces. If we are to avoid beats between two or more different signals present in the receiver passband, the local signal must have a much greater amplitude than the incoming signals, just as in the three-signal case described earlier.

(3) Complex Modulation

It should be obvious that we don't have to confine ourselves to 1000 Hz tones. The modulating signal might well be a complex signal made up of different frequencies. For example, if our purpose were to transmit simultaneously a 2500 Hz tone and a 1000 Hz tone of greater amplitude, we could set up five transmitters as shown in Figure 1-5, with careful control of the relative phases so as not to have some 1500-Hz, 2000-Hz, 3500-Hz, and 5000-Hz signals in the receiver output. Or we could modulate the carrier with the 1000-Hz and 2500-Hz signals and get exactly the same effect at the receiver. In each case, we must make sure that the amplitude of the carrier being modulated is large compared to the total power of all the modulating frequencies. Otherwise, the unwanted beats, plus other distortion products, will appear.

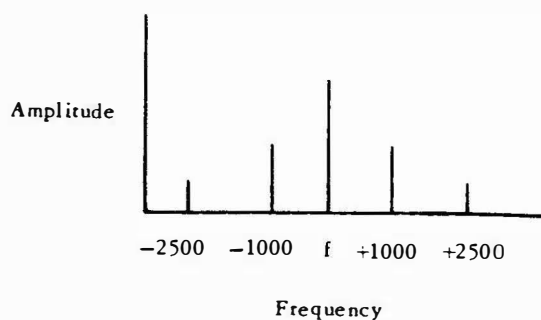

Figure 1-5. A Representation of Five Radio Signals

Speech and music are more complex than just two tones, but the principle is identical. The com-

plete AM signal consists of a steady carrier and the two sidebands. The individual side frequencies in the sidebands are determined by the complex components that exist in the audio modulating signal at the instant under consideration. In an AM transmitter the audio frequencies modulate ("beat against" or "are mixed with") the carrier in the modulated stage and thereby generate corresponding side frequencies. You would be just as correct, if not more so, to call the modulator an "audio power amplifier" and the modulated amplifier a "mixer" (as you would in a receiver).

(4) Carriers and Sidebands

Now let's tie in these concepts to the sideband problem. The signal that all the other signals modulate is called the "carrier." This signal merely furnishes a reference frequency and doesn't otherwise "carry" anything. Because the "carrier" conveys no intelligence, it doesn't have to be transmitted and might very well be supplied at the receiver. The signal generated locally in a SW receiver is called the "beat frequency oscillator" even though it does exactly the same thing as a transmitted carrier and could be called a "local carrier."

The intelligence is contained in the smaller signals and is recovered by beating or heterodyning them against the carrier (either transmitted or generated locally in the receiver). These smaller signals are called "side frequencies," and a band of them would be called a "sideband."

In a communication system based on the modulation of a large signal by a smaller one, the amplitude of the audio output from the receiver is proportional to the amplitude of the side frequencies. The frequency or audio pitch of the output is determined by the beat between the side frequencies and the carrier.

In the modulated stage, the carrier amplitude must always be at least twice the sum of the instantaneous (opposite) amplitudes of all the modulating frequencies, or overmodulation will occur. This means that, for a transmitter having 1000-watt carrier power for example, not more than 500 watts of downward modulating audio can be applied, and that the transmitter must be capable of 1500 watts of upward peak power. Therefore, a 1500-watt peak capability is needed to achieve 100% modulation, of which only 500 watts peak is usable intelligence.

Speech waveforms are characterized by occasional peaks which rise to an amplitude many times the average level. Statistically speaking, speech waveform peaks exceed 13 dB above the average level 1% of the time. However, effective speech power can be approximated by sine wave modulation at 30%, which is why a 30% modulated signal is used for receiver test purposes. Each sideband contains half the total modulating power which, for a 1000-watt carrier modulated 30%, is only 75 watts of usable intelligence per sideband. The carrier continues at its full power even when no information is being transmitted, such as during pauses between words and sentences. (E1B 623, 734)

(5) Single Sideband Transmission and Reception

Inasmuch as the carrier conveys no intelligence, it is possible to dispense with it at the transmitter and introduce it at the receiver instead. This will save transmitter power and reduce heterodyne QRM. If both sidebands are received at the detector

in which a carrier is reintroduced, the inserted carrier must have exactly the correct phase relationships with the sidebands if distortion is to be avoided. However, if only one sideband (or two independent, unrelated sidebands) is present at the detector, there is no need for an exact phase relationship and there can be some frequency error without destroying intelligibility. Two identical sidebands are not needed to convey intelligence, and the extra sideband can be removed either at the transmitter or at the receiver — one is single-sideband transmission and the other is single-sideband reception.

When the carrier is eliminated at the transmitter and reinserted at the receiver, its frequency must be set carefully. For example, if there is 100 Hz of cumulative frequency error in the several receiver oscillators, there would be an error of 100 Hz in the received audio signals. This is of no importance in radiotelegraphy, but receiver tuning for a single-sideband suppressed-carrier (SSSC) voice or teletype signal is quite critical. There are electronic means for simplifying the tuning, provided a weak carrier is transmitted to give a clue to the exact setting of the carrier at the receiver. Because the receiver must be carefully synchronized in frequency with the transmitter it is to receive, precision frequency control of both is needed.

If insufficient carrier is supplied at the transmitter during the modulation process, extra signals will be generated and radiated in the form of over-modulation and splatter. However, once the modulation (heterodyning) process has been completed, the carrier has served its purpose and can be attenuated, as in A3A emission, or eliminated entirely, as in A3J emission. If insufficient carrier is supplied at the receiver, extra signals will also be generated and heard.

Single-sideband techniques permit substantial savings in transmitter costs, size, and power consumption for a given information-carrying power. Think of that 1500-watt (peak) transmitting capability we needed to transmit only 75 watts (average) per sideband when we used 6A3. By eliminating or greatly attenuating the carrier, and emitting sideband energy only when a modulating signal is present, we can deliver the same communication effectiveness with a much smaller transmitter. 3A3A and 3A3J emissions occupy half the spectrum space of conventional 6A3 emission, relieving crowding and interference in the radio spectrum. Not only that, but receiver passband need be only half as wide, producing a corresponding improvement in signal-noise ratio. Alternatively, two independent sidebands (6A3B) can be emitted in the same 6 kHz spectrum space but with a greater message content compared to conventional 6A3 in which both sidebands carry the same message.

We can now discover why we are likely to be misled by the "modulation envelope" illustrations often used to depict AM. These drawings or scope patterns actually show the combined effect of several separate frequencies (three in our example of Figure 1-3) which, because of selectivity problems, are not easily separated into individual components. An understanding of the whole picture develops when we examine the signal with a spectrum analyzer or frequency selective voltmeter of sufficient selectivity.

Think of modulation, beats, heterodyning, mixing, and AM detection as exactly the same thing.

Forget about carriers transporting audio and all the other misconceptions. Visualize the audio signal modulating the carrier to generate sidebands, and (at the receiver) the sidebands modulating the carrier to produce the audio signal, and it should all begin to make sense. For mental exercise, visualize what happens when you remove the carrier during transmission and reinsert it at the receiver, or lop off one of the sidebands at the transmitter or the receiver. It will all add up easily when you know what "really" happens.

b. FREQUENCY MODULATION

Frequency modulation (FM) refers to a method of modulating an electromagnetic wave by varying its frequency in accordance with the intelligence to be transmitted. It is a form of angle modulation in which the angular velocity of the wave is made to vary according to variations in the modulating signal.

The FM signal analogous to on-off keyed CW is called radio frequency carrier shift (RFCS) or frequency shift keying (FSK). Figure 1-6 shows an RF waveform which changes abruptly in frequency while remaining constant in amplitude. This frequency-modulation technique is known as F1 emission (see Table 1-1) in which the frequency is changed between two discrete values by opening and closing a keying circuit.

An RF emission that is frequency modulated by a single audio tone will produce F2 emission (see Table 1-1). The modulating components and the frequency-modulated RF output are shown in Figure 1-7. Increasing the frequency of the audio modulating signal will increase the number of times per second that the modulated radio frequency passes through the center frequency. The effect of increasing the amplitude of the modulating signal is to increase the frequency deviation without affecting the number of frequency excursions per second.

Frequency modulation by a complex modulating wave as in voice or single-channel (2 alternate tones) RATT produces F3 emission. This type and other even more complex waveforms are listed in Table 1-1. Any complex modulating wave can be analyzed into a series of sine waves of varying amplitude and frequencies.

In FM, the instantaneous frequency of the radio frequency wave is varied in accordance with the modulating signal, while the amplitude of the emission is kept constant. The number of times per second that the instantaneous frequency is varied from the average (carrier frequency) is controlled by the frequency of the modulating signal, and the amount by which the frequency departs from the average is controlled by the amplitude of the modulating signal. The amount of variation is called the frequency deviation of the FM wave.

The frequency spectrum of FM is considerably different from that of AM. In the latter, the practical spectrum is equal to the highest modulating frequency for single-sideband and twice that value for double-sideband. In frequency modulation, this is not the case. For each modulating frequency there are an infinite number of sidebands. For instance, with a 500 Hz sinusoid modulating a carrier, the modulated wave contains the carrier, a pair of first-order sidebands 500 Hz either side of the carrier, a pair of second-order sidebands located 2×500 Hz or 1000 Hz either side of the carrier, a pair of

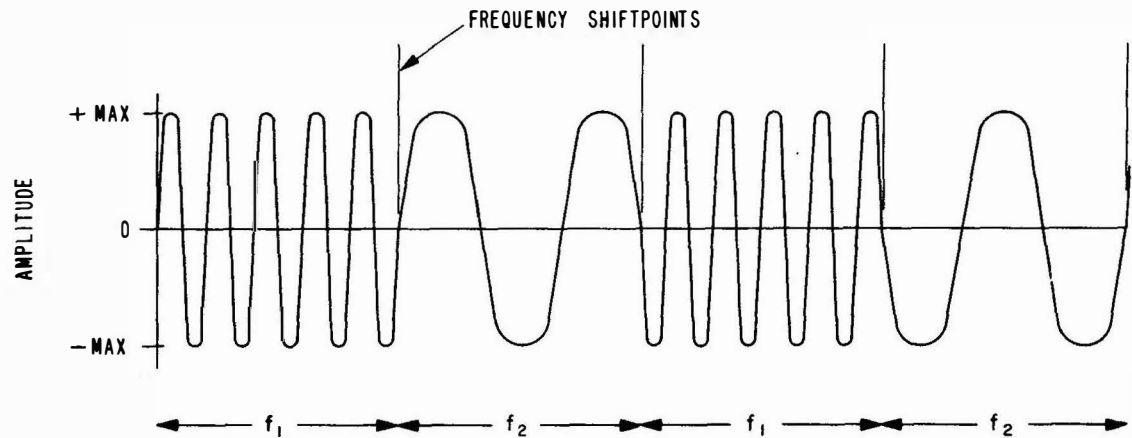

Figure 1-6. F1 Waveform (Frequency-Shift Keyed)

third-order sidebands at ± 1500 Hz, etc. Their relative amplitudes are a function of the modulation index. Because the modulation index varies with the amplitude of modulating wave, the amplitudes of the various sidebands will vary.

Inasmuch as the amplitude of the FM envelope is unchanged by modulation, the total power in the carrier and the sidebands is equal to the power of the unmodulated carrier. The term "occupied bandwidth" refers to the width of the spectrum within which 99% of the total power falls. For certain values of modulation index, the carrier amplitude becomes zero and the entire FM wave consists of sidebands of various orders. A useful rule is that an FM wave contains sidebands of importance on either side of the carrier wave over a frequency band approximating the sum of the frequency deviation plus the modulating frequency. The "necessary bandwidth" in which most of the energy of the wave is contained is then twice this value. The various frequencies within this band will be spaced at intervals that are equal to the modulating frequency, and so will be closer together at low modulating frequencies than at high. Adding frequencies to the modulating wave does not necessarily increase the modulation index; rather it increases the number of spectrum lines in the FM sidebands.

The bandwidth assigned for FM must be great enough to allow a reasonably high modulation index at the highest modulation frequency. When the modulating signal is composed of more than one sinusoid, as in voice or RATT, the determination of the spectrum becomes very difficult because the modulation of the carrier by one sinusoid is not independent of the modulation of the carrier by other frequencies. Sidebands are generated at frequencies corresponding to the sum and difference of each modulating frequency, plus its harmonics and the intermodulation products with all other modulating frequencies and their harmonics.

When a frequency modulated signal is passed through a frequency doubler or other frequency multiplying amplifier, the effect is to increase the modulation index by a factor equal to the frequency multiplication involved. No distortion is introduced by the mere fact of multiplication, however. If, by heterodyne action as in a receiver, the FM wave is translated to a new portion of the spectrum, the modulation index and the bandwidth are unchanged.

FM systems are of two types, wideband and narrowband, and the selection of one over the other depends upon the use to which it is to be put. With a large deviation (wideband FM), circuit and antenna noises which are weaker than the desired signal are more completely suppressed than in the narrowband systems. However, the frequency spectrum over which the noise is accepted by the receiver is also greater. For multichannel systems such as microwave, TACSAT, and tropospheric scatter, the deviation may be made great enough to accommodate the maximum bandwidth desired.

The greater bandwidth requirements of FM as compared to AM makes it impractical to assign wideband FM channels below the VHF region of the electromagnetic spectrum; that is, below about 70 MHz. However, there are many narrowband FM services such as RFCS, and even narrowband FM voice, at lower frequencies. The only bar to the use of FM at any frequency is bandwidth that can be accommodated, as by an antenna for example, or by neighboring services which must share the spectrum.

Many public and government services that previously operated wideband FM in the frequency range of 25-70 MHz are now being required to change over to narrowband FM. This includes the military. The older SCR-608, AN/SRC-10, 11, 12, etc., equipments, many of which are still in use, are wideband FM and therefore they have difficulty in netting with the newer narrowband equipments such as the AN/VRC-46. While a wideband receiver can process a narrowband

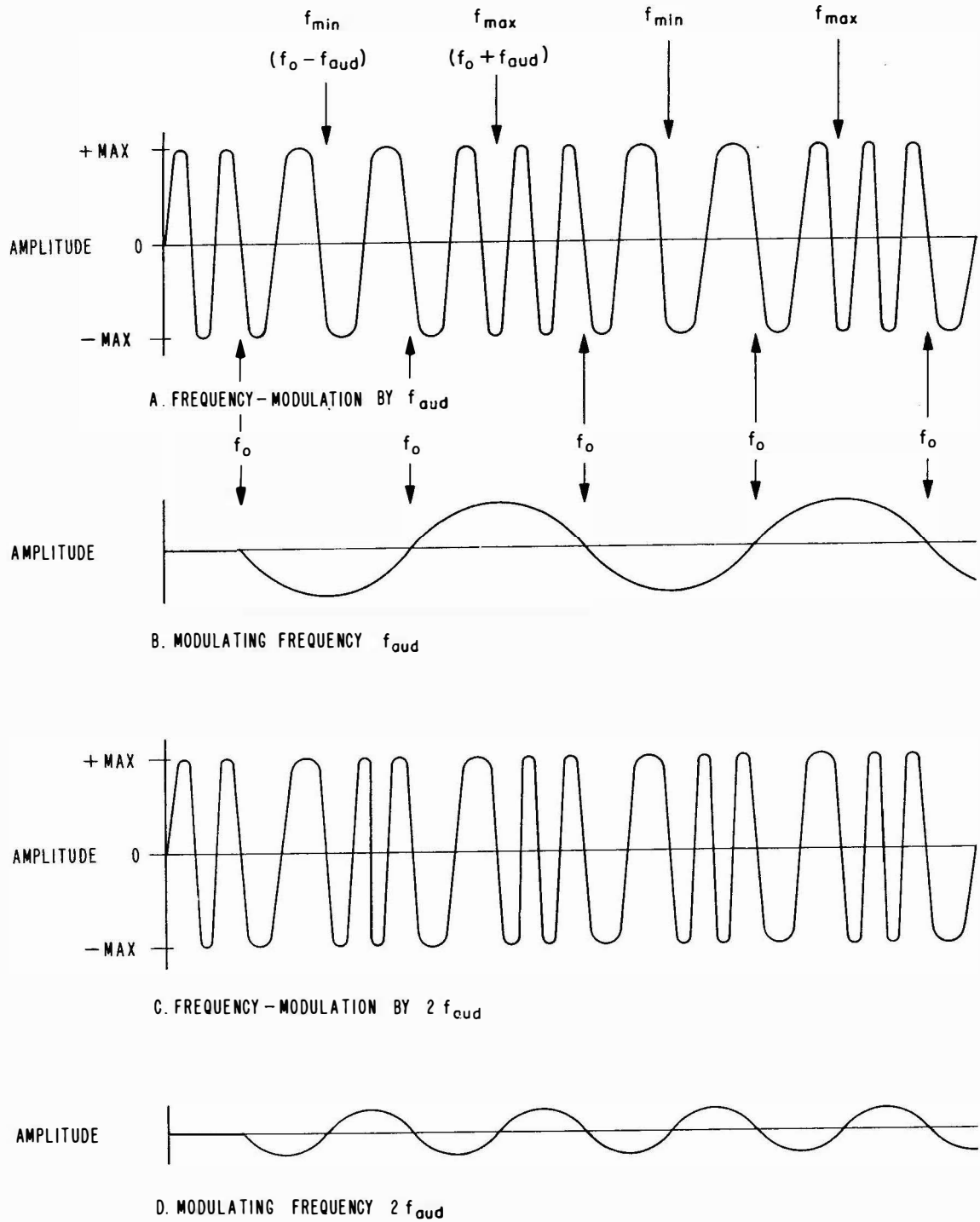

Figure 1-7. F2 Waveform (Frequency-Modulated by a Single Audio Frequency)

signal with results no worse than reduction of effectiveness, the converse is not true. A wideband signal into a narrowband receiver will be received as severe distortion.

1-3 THE IMPORTANCE OF FREQUENCY ACCURACY

New advancements in communication systems in recent years have provided the fleet with more and better capabilities. With these new systems, however, frequency accuracy problems have arisen which often have resulted in poor circuit performance. Frequency errors approaching 0.02% (200 Hz per MHz), which is the legal limit imposed by the ITU Atlantic City Convention, cannot be tolerated by synchronous communication systems such as SSB, ISB, FSK, and MUX. Synchronous communication circuits require that each transmitter and each receiver in a circuit be synchronized in frequency to a high degree of accuracy. For single sideband voice circuits, frequency accuracies as high as one part in ten million (1 Hz per ten MHz) are required. Frequency tolerances for multi-channel teletype call for an accuracy on the order of 0.1 Hz per 10 MHz.

a. EFFECT OF FREQUENCY ERRORS ON VOICE CIRCUITS

What happens to voice circuit performance in the presence of frequency errors? As an example, let us consider the measured effects during a recent fleet operation. The stations of one single-sideband net were operating with a frequency spread of +200 Hz. As a result of synchronism errors, voices sounded like people either talking from the bottom of a barrel or chirping like birds.

This 3A3J circuit and 6A3 voice circuit were given a voice intelligibility test commonly used in telephone circuit analysis. This test measured the number of words, which, after being transmitted over a circuit, were confused with words that sound almost the same except for one critical phonetic sound. An articulation index was then derived from this error rate. As compared to an articulation index in excess of 90% for a good telephone circuit, the SSB circuit had an index of 35% and the 6A3 voice circuit had an index of 46%.

If the articulation index had dropped below 25% due to cumulative personnel, propagation, and frequency error factors, the error rate for sentences would have arisen very sharply. In other words, the SSB circuit had only a 10% margin before it became critical, as compared to a 21% margin for the 6A3 voice circuit.

These two circuits differed mainly in that a frequency error on the SSB circuit translated into a voice frequency error whereas the 6A3 circuit was not affected in the same manner. This means that, if the stations on the SSB net are not synchronized within ± 5 Hz of the correct frequency the circuit will be degraded, leaving but a small margin for further degradation that may be contributed by personnel, propagation conditions, and/or equipment.

b. EFFECT OF FREQUENCY ERRORS ON FSK TELETYPE CIRCUITS

On multi-channel A7J teletype, each of the first 5 Hz of frequency error can be translated into 1% bias distortion; each of the next 5 Hz would contribute 2%

distortion, and by the time the signal is 20 Hz off frequency, bias distortion would render the circuit unusable even with near-perfect signal strength.

During the aforementioned fleet operation, it was found that, when average bias distortion reached a level of about 25%, the peaks of distortion were in excess of 40%, resulting in printing errors on the circuit. Additionally, it was found that bias distortion on what could be considered good teletype circuits was averaging between 10% and 15%. This would indicate that the margin for additional distortion is only about 10%. Based on a 10% allowable margin of distortion, it would appear that there remains a cushion of ± 8 Hz of frequency error. This cushion must be shared between four pieces of equipment; the transmitter, the receiver, and the transmit and receive multiplex terminal units. By the time the multiplex terminal units take their allocated share of this tolerance, only 4 Hz remain to be shared between the transmitter and the receiver.

In view of this, some question may arise concerning the manner used to terminate multi-channel teletype circuits. For fleet multi-channel broadcasts, shore facilities are likely to be on the correct frequency within a close tolerance; however, tests show that this is not always the case. Shipboard receivers used for multi-channel broadcast commonly use stabilized internal reference oscillators to control their frequency. If their reference oscillators have been recently tested, and readjusted where necessary, it is unlikely that they would have drifted off frequency by any large amount. Therefore, with reasonable care, synchronism between transmitting and receiving terminals should be possible within the tolerable frequency error.

In order to compensate for frequency errors of shipboard transmitters, an alternative method can be used in which the ship transmits a pilot frequency and the receivers use automatic frequency control to lock onto the transmitted signal. This method works fine except that the circuit becomes more susceptible to outage in the presence of poor propagation. This is because the transmitter must use a part of its available power for radiating a carrier which, as previously pointed out, does not contribute to intelligence contained in the modulation (except as a frequency reference). Additionally, the capabilities of the receiving terminal to use frequency diversity to compensate for selective fading is degraded, because of the susceptibility of the receivers that use automatic frequency control to this same selective fading.

c. EFFECT OF FREQUENCY ERRORS ON NON-SYNCHRONOUS CIRCUITS

Frequency tolerances of types of communication circuits other than synchronous are not as critical, because a carrier is transmitted along with the sidebands. The emitted carrier bears the correct phase, amplitude, and frequency relationship to the sidebands (unless disturbed by propagation conditions) so there is no requirement for exact synchronization of frequency at the receiver. However, the frequency errors observed on circuits during the above-mentioned fleet operation were great. On a 6A3 amplitude-modulated voice circuit, at least one station had an error of 2 kHz. Of all the stations on the circuit, only 70% were observed to be within 500 Hz of the assigned frequency. This means that

if an R-390/URR receiver were used on this circuit, the receiver passband would have to be set at 16 kHz, instead of the proper setting of 8 kHz, if copy of all stations on the net was to be expected. The increased receiver passband would double the amount of receiver noise, which would reduce the receiver sensitivity (signal-noise ratio) by half, thereby degrading the receiver signal. The actual degradation might be even worse because the receiver would then be set to receive signals from adjacent channels which might be in use by other stations. The effect here is that, unless the receiving station either increases the width of his receiver passband or retunes his receiver for those transmissions that were in excess of 500 Hz off frequency, the transmissions would be missed or garbled.

d. DETERMINATION OF CORRECT FREQUENCY

Because it is obvious that frequency errors can degrade communication circuits, what can be done? The old procedure of zero-beating to the net control station is no longer applicable with synchronous-communication transmitters. For one thing, not all transmitters are capable of continuous tuning to permit setting them to the net control station. For another, the net control station can only designate the correct frequency; he cannot determine it for all bands.

The correct frequency throughout the entire military establishment is determined by the U. S. Naval Observatory. This correct frequency is given to each ship in the form of a frequency standard (AN/URQ-9 or AN/URQ-10) that is periodically corrected by calibration laboratories. Ships do not have the capability, by listening to WWV, of determining the correct frequency to the tolerance required. The frequency standard is the only method at present to determine the correct alignment of internal reference oscillators of each piece of equipment aboard ship.

There is hardly a piece of electronic equipment aboard ship that does not depend upon an accurate determination of frequency. The technical manual for an equipment may proclaim some fantastic stability, but this does not guarantee the frequency accuracy of the equipment. The frequency stability only states how quickly the oscillator will drift off frequency. It is the nature of all oscillators, even the most precise, to drift off frequency. As an example, AN/WRT-2 equipments were inspected aboard 40% of the ships participating in the subject fleet operation. Of those inspected, 87.5% were incapable of operating within the frequency tolerance proclaimed for the transmitter because their internal reference oscillators were off frequency. Some of these errors would have resulted in transmitted frequency errors of several hundred hertz.

e. EFFECTS OF ALIGNMENT AND ADJUSTMENT ERRORS

Errors in the internal oscillators of equipments would not account for frequency errors in the kilohertz range. Errors that large could only be caused by improper assigned frequency dial settings, misalignment of transmitter frequency generation circuits, or by the mistuning of transmitters when used in their continuous-tuning mode of operation. As an example, one measurement revealed a 7-kHz error between the transmitter frequency output and the transmitter dial indication.

There is no reason why each transmitter having a stabilized internal reference oscillator cannot be set

to ± 1 Hz. If the internal reference oscillators of all synchronous-communication equipments are checked weekly against the AN/URQ-9 or AN/URQ-10, this accuracy can be reached. A better alternative would be to use the external frequency standard in place of the internal reference oscillator where transmitter design permits.

If the ship uses continuous-tune transmitters, a calibrated frequency counter may be used to assure an accuracy between 10 and 100 Hz. Higher degrees of accuracy may be achieved by substituting the output of the frequency standard for the internal reference oscillator of the counter. A frequency counter used in this manner should also be employed to check the output frequency of stabilized transmitters to make sure that alignment errors in the frequency-generating subassembly are not causing an off-frequency condition.

Synchronous-communication receivers of the AN/WRR-2 variety should have their reference oscillators checked weekly. The R-1051/URR receivers that are used on fleet multichannel broadcasts should use the external frequency standard continuously, or else be checked every other day against the standard. Net control stations should check the transmitted frequencies of all ships in the net, using an R-1051/URR receiver.

f. FREQUENCY SYNTHESIZERS AND STABILIZED OSCILLATORS

Frequency control for synchronous communications in which the carrier is suppressed is much more critical than for those modes of emission in which a reference carrier is transmitted. Formerly, only a crystal-controlled oscillator could satisfy the frequency accuracy and stability requirements, and extensive sets of crystals were needed to achieve frequency agility. Today, frequency synthesizers or stabilized oscillators are used to provide the necessary accuracy and stability, and at the same time provide the wide range of frequency selection of a variable-frequency oscillator. Generally, due to crowded frequency assignments and variations in propagation conditions it is desirable to be able to select any frequency in the entire 2-30 MHz frequency range in increments of 0.1 kHz. Without a synthesizer, this tuning range would require a set of 280,000 crystals for the transmitter and an equal number for the receiver. It would be difficult even to find room aboard ship for such a set of crystals, and chances are that the crystal you needed would be lost anyway.

The name "frequency synthesizer" sounds complicated, but the general idea is easy to understand. A frequency synthesizer is a device which uses a single reference oscillator to generate other frequencies. It does this by applying the reference frequency to dividers and multipliers to develop the required frequency steps or increments, and then combining the divider and multiplier outputs in mixer stages to synthesize the desired output frequency. The frequency synthesizer employs the beat frequency concept discussed under Subsection 1-2 Types of Emission to generate new frequencies. Furthermore, because net operation requires precise synchronization of transmission and reception frequency, it is often a design practice to use one frequency synthesizer for both transmitter and receiver.

A frequency multiplier uses a harmonic generator which is any nonlinear circuit or device that dis-

torts or "squares off" a sine wave input. Harmonics are exact multiples of the basic or fundamental frequency. Thus, a nonlinear amplifier rich in second harmonic distortion produces an output which contains substantial energy at precisely twice the input or fundamental frequency. Type of harmonic generators include nonlinear amplifiers, diodes, saturable reactors, flip-flops, and almost any circuit in which the output is not a replica of the input. Filters must be employed following a harmonic generator in order to select the desired harmonic and to reject the undesired frequencies. Careful alignment of these filter-amplifier circuits is needed to make sure that the proper harmonic is selected and that all others are adequately suppressed.

There are classes of circuits that behave as frequency dividers. Each stage of a binary counter is a "divide by two" circuit; a "nixie" tube provides "divide by ten" capability; and other circuits such as single-shot multivibrators provide any desired count-down capability.

By mixing combinations of various frequency multipliers and dividers, practically any output frequency can be generated from one master crystal oscillator. The discussion of Principles of Single-Sideband Reception under Subsection 1-8, Receivers contains text and illustrations of a frequency synthesizer system capable of tuning to any of a wide range of frequencies in 1-kHz increments. By dividing the 1 kHz increments in a 10:1 divider and adding appropriate filters and mixers, frequency increments of 0.1 kHz are possible.

Another form of frequency generator having high stability and accuracy is one which resembles a free-running variable frequency oscillator but which in fact is stabilized by being phaselocked with a high-stability frequency standard. This type of oscillator is usually called a stabilized local oscillator (STALO) or stabilized master oscillator (SMO). In operation, a sample of the oscillator output is compared with marker frequencies developed from the output of a frequency standard. The comparison is made in a comparator or phase detector circuit which is a frequency deviation detector similar to an FM discriminator. The comparator develops, when phase lock is achieved, a DC error signal proportional to the amplitude and direction of frequency error of the STALO (SMO). This DC error signal is then applied to a feedback network to correct the STALO (SMO) error. A panel meter enables the operator to read the value of the error signal, and more important, to ascertain that the STALO (SMO) is phase-locked with the reference oscillator. This type of frequency control can produce the desired output frequency directly without generating a multitude of harmonic and mixer products which would have to be suppressed. This reduces the need for extensive and complicated filters.

Trouble points to look for in frequency synthesizers and stabilized oscillators include:

1. Trouble Point
Small frequency errors (less than 1 kHz)
Cause
Aging of reference crystal.
Failure of temperature control in control in crystal oven.
Failure of corrective feedback circuit.
2. Trouble Point
Large frequency errors (increments of 1 kHz, 10 kHz, etc.)

Cause

Improper alignment of selective filter-amplifiers.

Improper count-down in divider circuits.

3. Trouble Point

Difficulty in achieving phase lock.

Cause

Insufficient harmonic amplitude into comparator.

4. Trouble Point

Spurious emission at 1 kHz, 10 kHz, etc. increments from desired frequency.

Cause

Improper alignment of selective filter-amplifiers.

g. AN/URQ-9 AND AN/URQ-10 FREQUENCY STANDARDS

The Frequency Standard AN/URQ-9, and its transistorized counterpart—the AN/URQ-10, are reference standards intended to provide accurate frequency references against which the frequency of various frequency generating elements may be compared, or for which the reference signals may be substituted. Included in the category of frequency generating elements are: local oscillators of transmitters and receivers, input drive signals for frequency counters or synthesized signal generators, and reference inputs to electronic clocks and related equipment.

It has been determined by personal interview and written survey with fleet personnel that the use of the frequency standard is not well understood. It has also been ascertained that a high percentage of units now installed in ships' communications spaces are not being properly maintained.

As indicated by the name reference frequency standard, the AN/URQ-9 and AN/URQ-10 do not measure frequency. They are highly stable and accurate references against which other signal sources may be compared. The actual comparison may be performed by a technician using a frequency deviation meter and possibly an amplifier for one or both of the signals being compared. The comparison may also be performed automatically by a comparison circuit built into the equipment being serviced. This does not mean that the necessary adjustment is accomplished automatically. It merely means that the technician will not need to carry test equipment to the user (primary) equipment site to determine that an "off-frequency" condition exists. Further discussion of automatic, semi-automatic and manual frequency measurement techniques is beyond the scope of this article. The point to be remembered is that the frequency standard is a reference, not a meter or test instrument.

Since many equipments contain their own "frequency standards," you may ask why we have the AN/URQ-9 and AN/URQ-10. The answer is simple. In order to calibrate the less accurate standards (approximately 1/10th as accurate) built into many equipments, the AN/URQ-9 and AN/URQ-10 frequency standards are calibrated in Navy calibration laboratories, then delivered "hot" to ships and shore installations where they must each be connected to a reliable power source to ensure that they retain the stability which has required 2 months or more to establish. Note that the "hot" condition is maintained by standby battery operation. This is limited to 2

hours for the AN/URQ-9, and 8 hours for the AN/URQ-10. Where the standard is used to drive precision timing devices, counters, synthesizers and such, it is obvious that an accurate and stable "house standard" or ship's standard is required. The ship's standard is the AN/URQ-9 or 10.

In order for the standard to continue to serve its intended function, it will be necessary to return it periodically to a laboratory for calibration. This should be done at least every 6 months. As is the case with all crystal oscillators, those employed in the frequency standards are subject to drift. Therefore, the accuracy of the unit will eventually degrade so that recalibration is necessary.

Drift is due to aging of the crystal which is the heart of the oscillator. As a rule, the older the crystal the more stable it will be. This rule holds true only if the crystal is undisturbed. It can be disturbed by shock, vibration, inclination, temperature

changes, effects of moisture, voltage variations and other changes in environment. It is within this framework that we speak of stability in terms of 1 part in 10^9 per day, or 1 part in 10^8 per 60 days. We mean that if the unit is kept operating so that the crystal is not disturbed, the output frequency will not vary from the assigned value by more than one ten-millionth of one percent of the assigned value within any 24 hour period, and not more than one millionth of one percent of the assigned value within any 60 day period. For a frequency of 5 MHz, this translates to a maximum deviation of 0.005 Hz within a 24 hour period and 0.05 Hz in 60 days.

It is necessary to maintain the battery pack in both the AN/URQ-9 and 10 to ensure that input power is maintained and that the output signal levels are matched to the user equipment input tolerances. To facilitate these tasks, Table 1-2 presents a brief summary of characteristics for both frequency standards.

TABLE 1-2. CHARACTERISTICS OF FREQUENCY STANDARDS AND ASSOCIATED DISTRIBUTION AMPLIFIER

Characteristics	AN/URQ-9	AN/URQ-10	AM-2123/U
Height (inches)	11	7-13/16	5-7/32
Width (inches)	21 (incl. case)	5-1/2	19
Depth (inches)	13	15-5/16	8-1/2
Volume (cubic feet)	1.78	0.38	0.33 (max.)
Weight (pounds)	70.8	22	16
Normal Mounting	19-inch rack	3 abreast in 19-inch rack	19-inch rack
Input Voltage	115V($\pm 10\%$) at 60 Hz (± 3 Hz)	115Vrms at 50 to 400 Hz	115Vrms at 50 to 400 Hz
Input power	56 Watts nominal; 240 max	15 Watts nominal	26 Watts nominal
Operating Temperature Range	0° to 50°C	0° to 50°C	0° to 50°C
Output Frequencies	0.1, 1.0 and 5.0 MHz	0.1, 1.0 and 5.0 MHz	0.1, 1.0 and 5.0 MHz
Output levels:			
50-ohm load	1 volt (min)	1 volt (min)	4 to 5 volts rms based on input of 0.5 to 5.0 volts rms
1-megohm load	2 volts (min)	2 volts (min)	
Continuous operation time on battery (after loss of primary power)	2 hours	8 hours	batteries not supplied with unit
Output spurious levels (50-ohm load)	0.1 mV (max)	0.1 mV (max)	at least 80 dB down
Output harmonic levels (50-ohm load)	10.0 mV (max)	10.0 mV (max)	at least 60 dB down
Frequency Stability (max drift)	1 part in 10^9 per day and not more than 1 part in 10^8 in 60 days	1 part in 10^9 per day and not more than 1 part in 10^8 in 60 days	N/A

When user equipments are located remotely from the frequency standard, it will be necessary to employ Radio Frequency Amplifier AM-2123(V)/U to sustain signal strength of the reference signal enroute to the user equipment. The amplifier will boost the output of the frequency standard from 1 volt to a maximum of 5 volts. In a low-loss, coax, 50-ohm distribution system, this will adequately serve distances of more than 1,000 feet. Input tolerances for some user equipments may dictate the need for attenuators to prevent overdriving the reference input circuits. Consult the technical manuals for user equipments prior to use.

For additional information on AN/URQ-9, AN/URQ-10, and AM-2123(V)/U, refer to the technical manuals indicated below. If further information is then required, consult your nearest calibration facility or NAVSEC 6181D. (EIB 712)

Equipment Model	Publication Number
AN/URQ-9	NAVSHIPS 0967-007-8011 (Change 2) (formerly NAVSHIPS 93805(A)) dated 3 April 1967
AN/URQ-10	NAVSHIPS 0967-053-7010 (Change 1) dated 21 Oct 1966
AN/URQ-10A	NAVSHIPS 0967-170-3010 dated 15 Sept 1966
AM-2123(V)/U	NAVSHIPS 0967-136-1010
AM-2123A(V)/U	NAVSHIPS 0967-225-9010 dated 23 Jan 1967

h. FREQUENCY STANDARD SYSTEMS

Frequency Standards AN/URQ-9, 10 provided to ships are intended for installed system use and not as a "test equipment." The AN/URQ-9 and 10 provide a much higher order of frequency accuracy than that provided by frequency standards included within most new equipments. The frequency standards do not measure frequency, they provide highly stable and accurate reference signals against which other signal sources such as the Translator-Synthesizer unit of Radio Receiver R-1051/URR may be compared. When an AN/URQ-9 or 10 is provided to a ship, it should be permanently installed as a central system. (See Figure 1-8)

Equipments such as the AN/WRC-1, AN/URC-35, AN/WRR-2, AN/URT-23, AN/URT-24, and R-1051/URR are examples of communication equipments having the capability of using either an internal or external frequency standard. The internal frequency standard unit of these equipments is intended for use in installations not having an AN/URQ-9 or 10 installed or for backup use in the event of any failure of the installed external frequency standard system. Where there is no installed central reference system, the equipment's internal frequency standard must be calibrated periodically against an external frequency source, such as a portable AN/URQ-10, to maintain their rated accuracy. Frequency standard "age" with time, causing drift and a reduction in frequency accuracy.

It is essential that equipments such as the R-1051/URR, AN/WRR-2, and AN/URT-23, when used with multiplex equipment AN/UCC-1, use an

installed ships frequency standard system in preference to the equipment's internal standard for maximum circuit reliability.

The basic frequency standard system, as shown in Figure 1-8, utilizes RF Amplifier AM-2123/U for isolation and distribution of 0.1, 1, and 5 MHz frequencies generated by the AN/URQ-9, 10. This RF amplifier must be used when more than one transmitter or receiver is to be connected to the frequency standard. The AM-2123/U accepts the three input frequencies from the frequency standard and provides 12 isolated outputs in any combination of the three input frequencies.

When installing the AM-2123/U, an appropriate amplifier plug-in module must be installed for each individual equipment for which it is to be used; i. e. 5 MHz modules for the AN/WRC-1, AN/URC-35, AN/URT-23, AN/URT-24, and R-1051/URR; 1 MHz module for the AN/WRR-2. If additional modules are required to change the frequency complement of the amplifier, they may be ordered on an exchange basis from ESO. The FSN for the amplifier modules are as follows:

AM-2123/U (0.1 MHz amplifier)	IN5820-940-3259
AM-2123/U (1 MHz amplifier)	IN5820-940-3260
*AM-2123/U (5 MHz amplifier)	IN5820-940-3262

*The AN/WRC-1 equipment requires two inputs, one for the transmitter.

Most communication equipments are designed to accept a reference input at a maximum level of 3 volts rms. The output of the AM-2123/U may be as high as 5 volts rms; however, the level of the signal at the user end of the reference feeder cable may be considerably lower than the 5-volt level at the source end. Attenuation over the cable run depends on the length of the run and the frequency. The voltage should be measured at the time of installation. If it is greater than 3 volts, an attenuator should be inserted at the user end connector. A suitable attenuator for this purpose is NARDA Model 755-3 (FSN 9N-5905-862-3291), which provides 3dB attenuation.

NAVSEC drawing RE-F2687915 provides ship Frequency Standard System installation information. The appropriate communication equipment technical manual should be consulted regarding use of the external standard as a comparison reference in the calibration of the equipment's internal frequency standard.

NOTE

When calibrating an equipment's internal frequency standard, it is essential that the standard be energized for a continuous period (not less than two weeks preferred).

It is essential that the communication equipments be run continuously (operate or in "standby" condition) since the on-off cycling of the equipments' prime power will cause a degradation of the equipments' internal frequency standard unit. (EIB720)

1-4 UHF COMMUNICATION SYSTEMS

It has been demonstrated repeatedly that UHF can provide satisfactory communication over line-of-sight distances. However, all parts of the system

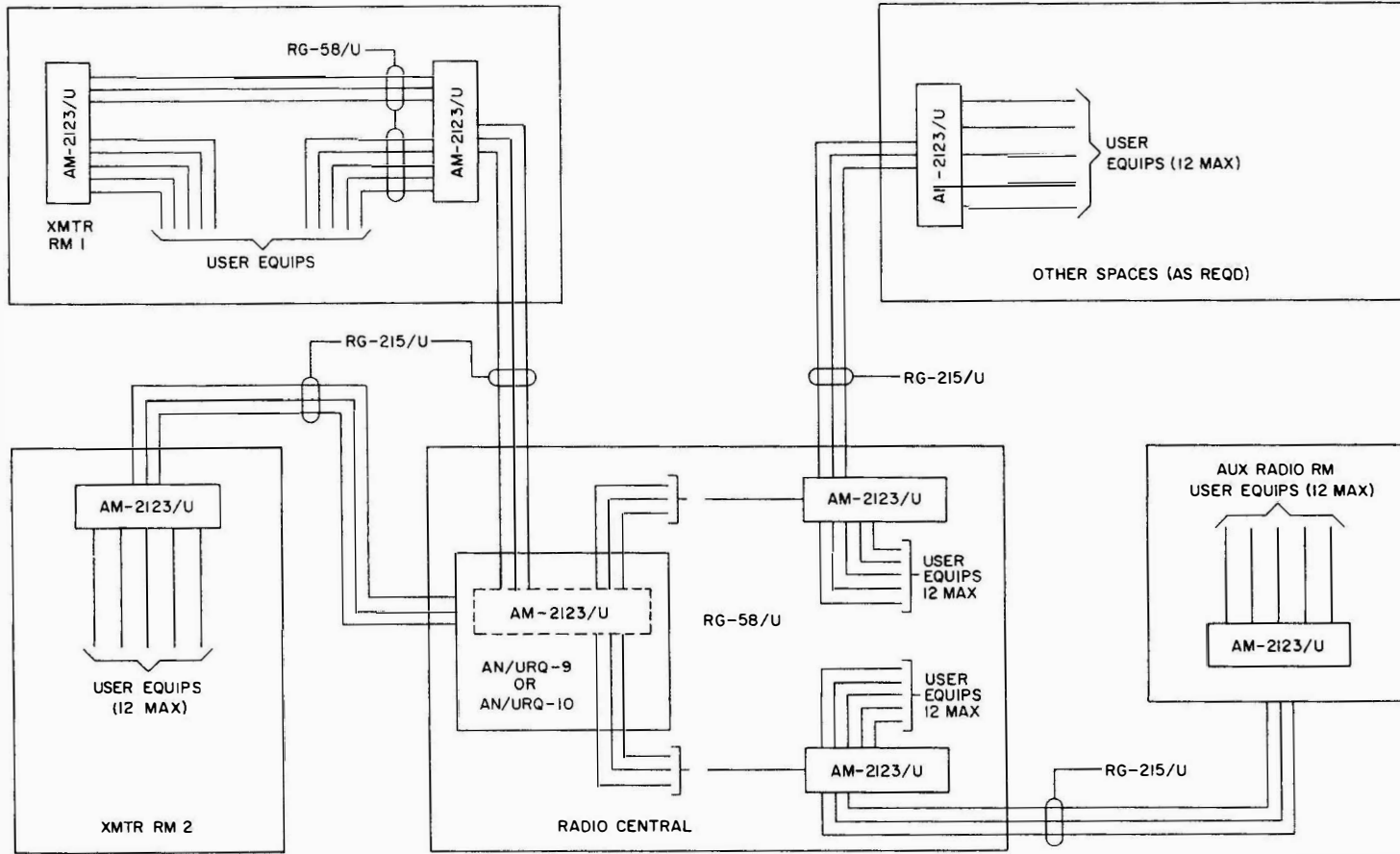

Figure 1-8. Frequency Standard Distribution Diagram, Typical Shipboard Installation

must operate normally in order to avoid communication failures. Thus it is desirable to have at hand some means of checking the parts of the system and the over-all performance.

A simple check with a nearby ship and a report of "I hear you loud and clear" indicates little more than that the equipment is turned on, patched to the right outlets, and on the same channel. It does not indicate whether a slightly greater range is obtainable. However, this indication can be obtained from the equipment with some additional work.

Adequate range is obtainable only by reducing the losses (expressed in decibels) over the complete circuit to a satisfactory low level. Assuming some signal-to-noise ratio at the headphones is necessary for satisfactory reception, it is possible to figure the transmitter power necessary if the receiver sensitivity, cable loss, receiving antenna gain, attenuation in space, transmitting antenna gain, and transmitter cable loss are known. It follows that for a known distance between stations, it should be possible to use the input meter of a Receiving Set, Radio AN/URR-35 or Radio Receiving Set AN/URR-13 to determine whether there are any unacceptable losses in the system. This over-all check is described in greater detail following some methods of checking parts of the system.

The methods described are not intended to replace the maintenance checks prescribed for equipments in applicable POMSEE publications, but are to be used with the maintenance checks to provide an over-all systems check.

a. RECEIVER SENSITIVITY

The receiver sensitivity should be measured. It should be possible to obtain a 10-dB signal-to-noise ratio with less than 10 microvolts input from a signal generator, such as RF Signal Generator Set AN/URM-26. This subject is described in the instruction book and maintenance standards book for the particular receiver under test.

The sensitivity of the receivers may be measured also through associated cables and connectors (including the transmitter antenna relay if the same antenna is used for transmitting and receiving) in order to aid in locating trouble in associated local cables and connectors.

Ships have reported unsatisfactory UHF communications with respect to distance, even though the sensitivity of the UHF receiver is 1 or 2 microvolts for 10 dB S+N/N ratio. Normal UHF communications can be expected out to 40 or 50 miles with aircraft at an altitude of 10,000 feet (line of sight) or 13 miles surface to surface. Ranges in excess of these, however, are common. If these minimum conditions cannot be met, the complete UHF installation should be checked.

A frequent cause of unsatisfactory UHF performance is misalignment of the receiver IF amplifiers. In some cases investigated, the receiver was found to have been aligned as much as 100 kHz off frequency. Misalignment of receiver IF should be suspected when better communications can be established on manual mode than on crystal mode of operation. However, a UHF receiver should not be used in the manual mode because of the tendency of the receiver to drift off frequency. The problem is further aggravated because, with the IF off frequency,

the RF amplifier cannot be made to track properly with the RF oscillator.

Off-frequency IF alignment comes about because most signal generators (AN/URM-25, AN/URM-26, LR) cannot be set accurately enough to a given frequency solely by reference to the signal generator dial. For proper alignment procedure, refer to Super-Heterodyne Receiver Alignment in Subsection 1-8.

b. TRANSMISSION LINE TESTS

With a suitable fitting for a megohmmeter (Radio Frequency Jack UG-21/U and Radio Frequency Adapter UG-29/U, the antenna cables can be checked. A resistance reading well below one megohm suggests a short circuit developing in the cable; a reading of several hundred megohms suggests that the inner conductor may be open. A more complete check of open circuits is given by shorting the insulated half of the antenna dipole to ground, but the protective paint makes this method unsatisfactory as a routine measure. Removing the antenna connector and shorting the inner conductor of the cable to the copper braid gives a useful check, but in one case this did not disclose an open circuit within the antenna itself.

It is desirable to ascertain the cable loss between the receiver and the antenna. This can be determined by disconnecting the cables from two antennas and joining the cables with a Radio Frequency Adapter UG-29/U connector in order to form a loop. Connect the signal generator to the receiver and adjust the attenuator to give a convenient reading, such as 0.25 ma, on the receiver's input meter. Then connect the receiver and signal generator to the two ends of the loop of cable and readjust for the same input meter reading. The difference between the two readings of the attenuator gives the total cable loss, roughly half of which is in each cable. This may be checked further by measuring other connectors on the mast to determine the exact loss in each cable. The loss in an average length of Radio Frequency Cable RG-218/U may be as low as 6 dB, but losses as great as 18 dB have been found in long runs of smaller cable such as Radio Frequency Cable RG-10/U. Input and output readings on any multi-couplers may be obtained at this time.

The previous check gives a positive measure of cable loss but requires making connections on the mast. A routine over-all check can be made from the receiver location with much less work. This is done by connecting the signal generator to one antenna cable and picking up the signal in a receiver connected to another antenna. With close spacing of antennas (about 6 feet) and moderate runs of Radio Frequency Cable RG-218/U, the round trip loss will be about 30 dB. With an antenna spacing of about 60 feet, the loss will be around 50 dB (20 dB more for a 10-to-1 increase in antenna spacing). Either figure will be greater with longer cable runs or smaller cable. This type of check can be made regularly in a few minutes, giving an early indication of cable or antenna trouble. It is superior to using a "megger" because it shows trouble that does not give normal megohmmeter readings. The two sets of measurements listed in Table 1-3 illustrate the point.

It is clear from these figures that antenna No. 3 developed an increased loss of about 16 dB, although it continued to check satisfactory (300 megohms) on a

"megger." This procedure is very helpful when the figures have been recorded from time to time and

when the magnitude of the round trip loss has been determined to be satisfactory.

TABLE 1-3. ROUND-TRIP ANTENNA MEASUREMENTS TAKEN AT FIFTH NAVAL DISTRICT HEADQUARTERS

	21 January		23 February		
	Attenuator (dB)	Loss (dB)	Attenuator (dB)	Loss (dB)	Change (dB)
Sig Gen direct	-56.0		-68.2		
Antenna #1 to #2 (about 40 feet)	-9.3	46.7	-15.9	46.6	-0.1
Antenna #1 to #3 (about 40 feet)	-9.2	46.8	-5.7	62.5	+15.7
Antenna #2 to #3 (about 4 feet)	-27.6	28.4	-17.7	44.8	+16.4

c. TRANSMITTER TUNING AND POWER CHECK

Most transmitter tuning should be done with RF Wattmeter ME-11/U substituted for the antenna. This not only eliminates interference with other ships, but enables proper tuning to assure loading for maximum power output under conditions of radio silence. The antenna circuit may be returned for maximum deflection on the transmitter tuning meter after the antenna has again been connected to the transmitter, since some standing wave conditions on the transmission line may make such retuning necessary. When in port, the wattmeter may be moved to the antenna end of the transmitter cable to check cable loss if the performance of the system warrants it.

A wattmeter or signal strength monitor may also be connected to an adjacent antenna to ascertain that the transmitting antenna is radiating power effectively. If a wattmeter is connected to the cable leading to an adjacent antenna, the reading is likely to be less than one watt. This is not adequate for a satisfactory system check using an ME-11/U type wattmeter, but it does give some confidence in the performance of the R-F cables and antennas. A more sensitive wattmeter such as the CAQI-430 series can be used provided not more than 0.1 watt (+10 dBm) is applied to the wattmeter. This may require an attenuator of adequate insertion loss and power capability. The CAQI-430 series wattmeter can make precision measurements of transmission losses in the antenna system in the same manner as described for using a signal generator with a receiver.

The quickest and easiest check is to use an AN/URM-50 signal strength monitor. Signal strengths and modulation quality checks are simple to make, and comparison of measured signal strengths against those made with antennas known to be good can disclose poor antenna performance. However, if a receiver is available near the transmitter, the receiving antenna checking procedure described previously can be used to measure the round trip loss in two antennas and their cables.

d. SYSTEM TESTING

For routine checking of the uhf system, it is more convenient to test both the transmitting and receiving portions of the system at the same time. This may be done by using uhf transmitter on its normal antenna, observing the input meter of a uhf

receiver connected to a separate antenna, preferably one on a different yardarm. Inasmuch as the signal varies as $1/d$ (inverse distance) within the horizon (changing to $1/d^2$ beyond), there is a direct relationship between the receiver input meter and the distance range on the surface that can be expected of the equipment. For ships with high antenna, the following should be experienced:

Input Meter (ma)	Distance Between Antennas	dB Below 0.1 volt
0.87	6 feet	9.0
0.82	60 feet	
0.74	600 feet	29.0
0.60	1 mile	49.0
0.36	10 miles	69.0
0.05	20 miles	95.0

Each installation will have to be checked when in good condition for the standards to be expected during routine testing or operating conditions. It is obvious that, except for meter readings above about 0.85 ma which are less accurate, observation of the RECEIVER input meter tells much more about the operation of uhf equipment than does the fact that "strength five" signals were received at all the distance listed in chart. The system described in the previous paragraph is applicable to equipment on the same ship, nested ships, or widely spaced ships. Therefore, it provides a useful tool to confirm satisfactory operation of uhf equipment and to assist in locating faulty equipment or installations. It provides a means of checking each channel of each transmitter against each receiver, to provide assurance that there are no inoperative channels. It does not, however, directly check the antenna radiation at all bearings, though this may be done also by swinging ship and observing the input meter variations.

In a normally sensitive receiver, the input meter changes close to 0.1 ma between 0.1 and 0.5 on the scale, for each 6-dB change in receiver input.

For those ships having Monitor, Radio Frequency AN/URM-50, rough operational standards may be determined when setting up the frequency plan. Each transmitter frequency should be monitored and a graph or chart made to indicate relative power output at each frequency. This does not check the

receiving portion of the system, however, and in many instances the antenna on the radio frequency monitor is not well located; if it is available, it should be used whenever possible.

In addition, there is the multicoupler problem that may be minimized by an extension of the tests and principles applied herein. Many cases of extreme losses have been noted by means of wattmeter tests, but tuning for maximum output is often a problem, especially when several frequencies close together are set up on the same multicoupler combination.

As in any system, it must be noted that often unrelated parts of the system can influence the operational capabilities of the plant. Therefore, quick and meaningful tests must be available to the technician, and preferably the operator, so any question as to system reliability may be readily resolved.

e. FREQUENCY COMPATIBILITY BETWEEN UHF EQUIPMENTS

Difficulty has been reported in establishing communications between UHF equipments having 1750 channels and those having 3500 channels. Service and operating personnel should be alerted to the closer frequency tolerances required for communicating between these equipments.

At present, 3500-channel equipments are almost totally limited to airborne applications. Because air-to-ground communication is the most utilized transmission path for UHF, shipboard technicians and operating personnel must assure that their equipment is maintained on frequency.

The problem of poor or no communication is normally diagnosed as incompatibility. In most cases, however, the problem is that the frequency accuracy of the 1750-channel equipment has not been maintained. Frequency accuracy incompatibility may be the result of a crystal-controlled oscillator being tuned for peak output instead of being tuned to the correct frequency with an accurate counter. In the case of multiple crystal oscillators in a frequency synthesizer scheme, this possibility is even more apt to be the reason because frequency errors are cumulative. Frequency inaccuracies should always be suspected when poor or no communication is established between 1750 and 3500 channel equipments.

The 3500-channel UHF equipments operate with a receiver bandwidth of 50 kHz at the 6 dB points; the 1750-channel equipments have a receiver bandwidth of 80 kHz. A transmitter frequency that may be well within the 80 kHz of the 1750-channel equipment may be barely within the 50 kHz bandwidth of the 3500-channel equipment. Furthermore, the receiver IF strip may have been aligned with an inaccurate signal generator so that the bandpass is not centered at the correct frequency. Therefore, communication may not be established, particularly if the transmitting station frequency error is in one direction and the receiving station error is in the other. A subsequent section, SUPERHETERODYNE RECEIVER ALIGNMENT ADJUSTMENTS, describes a method of attaining proper receiver alignment. Pertinent information also appears in AN/GRC-27, 27A Technicians Handbook NAVSHIPS 0967-031-8040. In any case, the frequencies of the transmitter and receiver oscillators should be set accurately during alignment and checked periodically thereafter, using a frequency counter.

Because of the more exacting tolerance, it is recommended that a periodic check of all UHF frequencies be made. The interval should be contingent on the amount of surface-to-air communications the particular ship conducts. (EIB 688)

1-5 TELETYPE EQUIPMENT

a. THE RATT PROBLEM

In recent years, the U. S. Navy has vastly improved its radio teletype capabilities by the introduction of several new items of equipment providing either single or multi-channel radio teletype (RATT) transmission modes. An added dividend acquired along with this new equipment has been an increased flexibility in the specific combinations of ancillary equipment that can be used. This situation, however, has caused certain problems in the specification of frequencies for radio teletype transmissions. In addition, there has also been some confusion over the proper emission designators to be used. This article should clarify some of these problem areas.

The Navy presently uses two types of RATT emissions, (see Table 1-4). Both variations require the use of two discrete radio frequencies to produce one channel of radio teletype: one frequency for the MARK signal and the other for the SPACE signal. At any given instant of time, one and only one of these frequencies is being emitted by a transmitter.

The two types of emissions are:

1. F1 emission-shifting an unmodulated radio frequency carrier back and forth between the two discrete frequencies of a teletype channel, one frequency being the MARK signal and the other the SPACE signal. This is commonly referred to as FSK (frequency shift keying) RATT and is single channel teletype unless time division is employed on the two discrete frequencies to achieve multichannel operation. For reasons of clarity, it is more descriptive if this emission is referred to as RFCS RATT (Radio Frequency Carrier Shift Radioteletype) instead of FSK RATT.

2. A7 type emissions (A7, A7B, and A7J)-keeping the radio frequency carrier constant and shifting back and forth between two discrete audio frequency tones to produce the MARK/SPACE signals of a teletype channel. Each channel of radio teletype information in an emission requires its own pair of tones. If frequency diversity operation is desired, the teletype channel information is duplicated on a second pair of tones. By international definition, this would be A7 type emission only if two or more pair of teletype tones (multichannel) are being transmitted. As there is no internationally agreed emission designator to be used when only one pair of teletype tones is being transmitted, the Navy uses A7 to denote single as well as multichannel RATT of this type. A7 type emissions have been referred to by a variety of terms, including Tone Modulated RATT, FSK RATT, VFTG, SSB RATT, DSB RATT, and ISB RATT. It is more descriptive if A7 type emissions are referred to as AFTS RATT (Audio Frequency Tone Shift Radioteletype) instead of the various foregoing terms.

Another mode of transmitting radioteletype signals is the "on-off keying" mode, mentioned here only for completeness. In on-off radioteletype keying,

the MARK is denoted by transmitting a signal on one discrete frequency and the SPACE is denoted by the absence of the signal. The emission designator is A1, A2, or F2, depending upon the particular mode variation being used. This radioteletype mode is rarely used by the Navy/Marine Corps.

The following types of emission designators are representative of those in use by the U.S. Navy and U.S. Marine Corps. In the standard four part emission designator, the first number indicates the "necessary bandwidth" required by the emission. The "necessary bandwidth" calculations for the older type emission designators (.6F1, 1.08F1, 1.7F1, 2.04A2, 2.85F1, 4F4) are based on formulas found in the Radio Regulations, Atlantic City, 1947. The "necessary bandwidths" resulting from calculations using applicable formulas in the current authority, Appendix 5, Radio Regulations, Geneva, 1959 (upon which most of the designators listed in Table 1-4 are based) differ slightly from the 1947 values. Furthermore, the 1959 bandwidth formulas are themselves now under study by the International Radio Consultative Committee (CCIR) of the ITU, and will probably be revised at a future international conference. Therefore, in the interest of continuity and clarity, the following steps have been taken:

1. The older designators involving primarily older equipment have been retained. The bandwidth stated in each case is slightly greater than that derived from the more recent formulas.
2. New designator "necessary bandwidths" have been calculated from the most nearly applicable formula in Appendix 5, Radio Regulations, Geneva, 1959.

The listing in Table 1-4 is not all inclusive. For example, the emission designators for various types of tone generated CW (AN/URC-32, AN/TRC-75, AN/PRC-47) have been omitted. In addition, for the sake of brevity, all possible variations of multiplexed emissions have not been listed. Although the offset of the CW tone from the suppressed carrier (dial) frequency may vary, the old 0.1A1 designator coupled with an assigned frequency is sufficient to permit netting. Care must be taken when incrementally tuned SSB receiving equipment is used on a CW net in common with transmitting equipment which employs a keyed carrier frequency for CW operation.

Notice that some necessary bandwidths have been specified to more significant numbers than others. This was done merely to provide a numerical difference between 60-wpm and 100-wpm teletype designators which, otherwise, would be identical if "rounding off" rules were followed. For example, 1A7J could be used to indicate either 100-wpm or 60-wpm single channel SSB AFTS RATT, depending on local operating procedures or practices.

Any emission may be used on an assigned frequency, providing the bandwidth does not exceed that authorized and the modulation type, transmission type, and supplementary characteristics are the same. One exception to this rule is the current CNO authorization for USN activities and forces to utilize emissions not exceeding 1.24A7J on all frequencies assigned with 1.24F1 emission.

It is also important that the radiated emission should be centered on the assigned frequency. In the event equipment limitations preclude centering, the

emission bandwidth must be confined within the authorized bandwidth of the assigned frequency and should be centered as nearly as possible.

Based on the expanded list of emission designators, the following are samples of OPORD or OPLAN use of a hypothetical frequency assigned by CNO to a command.

CNO assignment:

3010.5 (3009) kHz, 1.24F1, 3A3J, 3A7J

Possible OPORD authorizations:

- a. 3010.5 (3009) Hz, 3A3J-Telephony (SSB)
- b. 3010.5 Hz 1.24F1-100 wpm RFCS RATT
- c. 3010.5 (3009.9) Hz, 0.3A7J-100 wpm SSB AFTS RATT (if transmitters have 0.1 Hz incremental tuning capability)
- d. 3010.6 (3010) Hz, 0.3A7J-100 wpm SSB AFTS RATT interim assignment (if transmitters have only 1 Hz incremental tuning capability)
- e1. 3011 (3009) Hz, 1A7J-100 wpm SSB AFTS RATT (interim assignment due 1-kHz tuning)
- e2. 3011 Hz 1A7B-100 wpm ISB AFTS RATT (interim assignment due 1-kHz tuning)
- e3. 3011 Hz 1.24F1-100 wpm RFCS RATT (if required to net with SSB and ISB RATT equipment).

These assignments illustrate five possible channel or net uses of an available frequency. All of them cannot be used simultaneously in the same area. When all HF equipment is capable of 0.1-kHz incremental tuning, the illustrated "interim" assignments, in which the emission is not centered on the "assigned" frequency should be deleted.

As a matter related to spectrum conservation, it would be interesting to ascertain the operational flexibility that might be realized with the 0.3A7J emission. Providing adequate measures are taken in respect to equipment separation, power output, transmitter frequency accuracy, and receiver bandwidth, and if used only where operational needs dictate, it would appear that three 100-wpm RATT nets could be accommodated in an authorized 3-kHz bandwidth (e.g., 3009.6(3009), 3010.6(3010), 3011.6 (3011)).

The assignments listed as e1, e2, and e3 could have been on 3010 kHz, but in order to be as consistent as possible with the instructions in paragraphs 106d and 606d, JANAP 195, the 3001-kHz assignment is preferred. In cases involving single sideband (SSB) emissions, the suppressed carrier frequency is listed in parentheses, following the assigned frequency. This technique merely provides a reference point in that the suppressed carrier frequency is usually the frequency appearing on the transmitter dials. (EIB 711)

b. TUNING IN A SINGLE CHANNEL RFCS RATT SIGNAL

Many good RATT signals are so degraded at the receiver that they become either unreadable or take too many hits to be of much use. This is often the result of improper tuning of the receiver. The intent of this article, therefore, is to provide some understanding of the required tuning procedures for proper reception of RATT signals.

Single channel teletype transmissions in the MF and HF bands use a radio frequency carrier shift (RFCS) of 850 Hz, or ± 425 Hz with respect to the

TABLE 1-4. EXAMPLES OF RATT EMISSIONS

Designator	Type of Emission	Sample Equipment	Remarks
0.1A1	CW Manual Morse Telegraphy	TBK	
0.28A7J	60 wpm Single Chan SSB AFTS RATT	AN/SGC-1 w/AN/WRT-2 (HF)	Note 1
0.3A7J	100 wpm Single Chan SSB	AN/SGC-1 w/AN/WRT-2 (HF)	Note 1
0.6F1	60 wpm Single Chan RFCS RATT	TAD-7, AN/WRT-1 (LF/MF)	Note 2
0.98A7J	60 wpm Single Chan SSB AFTS RATT	AN/URC-32, AN/FRT-39, AN/TRC- 75 (HF)	Note 3
0.98A7B	60 wpm Single Chan ISB AFTS RATT	AN/WRT-2 (HF)	Note 4
1A7J	100 wpm Single Chan SSB AFTS RATT	AN/URC-32, AN/FRT-39, AN/TRC-75	Note 3
1A7B	100 wpm Single Chan ISB AFTS RATT	AN/WRT-2 (HF)	Note 4
1.08F1	60 wpm Single Chan RFCS RATT	AN/SRT-15, TBK (HF)	
1.24F1	100 wpm Single Chan RFCS RATT	AN/SRT-15, TBK (HF)	
1.5A7	60 wpm Single Chan DSB AFTS RATT	AN/SGC-1 w/TED (UHF)	
1.6A7	100 wpm Single Chan DSB AFTS RATT	AN/SGC-1 w/TED (UHF)	
1.7A7J	100 wpm 8 Chan SSB AFTS RATT*	AN/UCC-1 w/FRT-72 (LF)	Note 5
1.7F1	60 wpm 4 Chan Time Div RFCS RATT	AN/UGC-1 w/AN/SRT-15 (HF)	
2.04A2	1020 Hz AFT Beacon	AN/WRT-1 TED (MF/UHF)	Homer Beacon
2.85F1	100 wpm 4 Chan Time Div RFCS RATT	AN/UGC-1 w/AN/SRT-15 (HF)	
3A3J	Telephony (SSB)	AN/URC-32, AN/WRT-2 (HF)	
3A7J	100 wpm 16 Chan SSB AFTS RATT*	AN/UCC-1 w/AN/WRT-2 (HF)	Note 6
4F4	Facsimile	(HF)	
6A3	Telephony (DSB AM)	AN/SRT-15 (HF)	
10A3	Telephony (DSB AM Broadcast quality)	(MF)	
16F3	Telephony (FM Narrow Band)	(VHF) AN/VRC-46	
30F3	Telephony (FM)	AN/PRC-25, AN/VRC-12 (VHF)	
36F3	Telephony (FM)	AN/PRC-10 (VHF)	
80F9	Multiplexed telephony (FM)	AN/TCC-1 () w/AN/VRC-12 (VHF)	
120F9	Multiplex telephony (FM)	AN/TCC-3 w/AN/GRC-10 (VHF)	

*Based on measured data in the absence of precise mathematical formulas.

Note 1. The AN/SGC-1 produces 700-Hz and 500-Hz mark/space tones. Therefore, these emissions would be centered 600 Hz from the suppressed carrier in the chosen sideband with a plus-minus 100-Hz shift.

Note 2. This designator is retained to normally indicate a plus-minus radio frequency carrier shift of 85 Hz (total 170-Hz shift) for mark/space signals.

Note 3. The AN/URC-32 and AN/TRC-75 type equipment produce 2425-Hz and 1575-Hz mark/space tones. Therefore, the emission is centered 2 kHz above or below the suppressed carrier (dial) frequency, with a plus-minus 425-Hz shift for mark/space signals. Suppressed carrier (dial) frequency should be 2 kHz above or below the assigned frequency. Wherever appearing, the AN/FRT-39 type equipment is assumed to include ancillary equipment such as the TH-39/UGT.

Note 4. The AN/WRT-2 type equipment produces 425-Hz tones in the USB and LSB to indicate a mark or a space signal. Therefore, the emission is centered on the suppressed carrier (dial) frequency with a plus-minus 425-Hz shift for mark/space signals. Note that suppressed carrier frequency is the assigned frequency.

Note 5. This designator covers the use of the eight pairs of tones centered on 1615-Hz and below.

Note 6. If all channels are not keyed, the necessary bandwidth for this mode will actually be dependent upon how many and which specific channels are used. In the interests of simplicity, it is recommended that only the 3A7J designator be used to indicate HF-SSB AFTS multichannel emission.

assigned frequency. If the assigned frequency were 8694 kHz, this would be the center frequency to be radiated from the transmitter. Two signals would be transmitted alternately, and neither of the signals would be 8694 kHz. The teletype mark signal would be transmitted 425 Hz above the center frequency of 8694, and the space signal would be transmitted 425 Hz below the center frequency. This means that the transmitter would develop a mark signal of 8694.425 kHz and a space frequency of 8693.575 kHz. Only these two frequencies need be received, and the receiver should be set to receive them in the center of its reception "window" or passband.

Receivers used for reception of RFCS RATT signals vary in their details, but in general the receiver should be tuned in the following manner:

1. First set the receiver passband to a fairly narrow value, on the order of 1 kHz. Tune the receiver to the frequency of the desired RATT signal by observing the receiver INPUT or CARRIER LEVEL meter. Ignore the received pitch at this point, or better yet, turn the BFO off until the signal is tuned so as to center in the receiver passband. Then lock the main tuning dial if possible.

2. Turn on the receiver BFO and set its frequency 2.0 kHz BELOW the center of the receiver passband (2550 Hz for receivers used with older, unmodified TTY Terminal Units). This value is used because single-channel TTY converters use a passband centered at 2000 Hz in present units, or 2550 Hz for older units. Some receivers have an "FSK" mode in which the BFO is automatically set to the proper value by the mode switch. Other receivers are merely aligned so that the "zero beat" position of the BFO falls in the center of its travel; for these receivers, the proper BFO setting for RFCS operating must be found using step 3. Once the proper point on the BFO control is found, it is a good idea to mark it as the "FSK" setting.

3. Place the receiver BANDPASS control in the 2 kHz position (note that RFCS RATT emission is 1.24F1). With sufficient receiver output to drive the TTY converter, slowly and carefully tune the BFO (called "FREQUENCY VERNIER" in some receivers) until the two horizontal lines on the TTY converter oscilloscope are equal distances above and below the center reference line on the CRT graticule. When this condition exists, the receiver is properly tuned, with the received signal in the center of the receiver passband as well as in the center of the TTY converter passband. The common failing is to leave the receiver BFO at its center or zero beat position and tune the main dial so that the RATT signal is 2.0 kHz off frequency with respect to the center of the receiver passband. The fallacy of this procedure should be obvious if you think about it.

4. If the TTY printer now "prints inverted," the order of sidebands has been inverted in the receiver. This happens in some receivers on some of their bands. When this is the case, there are two alternatives available: either repeat steps 2 and 3, resetting the BFO ABOVE the center frequency rather than below, or else operate the TTY converter NORMAL/INVERT switch to the INVERT position. (EIB 713)

A field change has been developed for converting TTY terminal units to a center frequency of 2000 Hz instead of 2550 Hz so that those receivers

that now cannot be offset by 2550 Hz in a stabilized mode can be operated with a stabilized 2.0 kHz offset. TTY terminal units so converted will copy 2425 Hz as a mark and 1575 Hz as a space, which are the values currently used by the AN/URC-32, the AN/ARC-94, and some others.

In order to produce reliable copy of RFCS RATT signals, a receiver should be operated in a tuning mode that provides best stability and accuracy. By using TTY terminal units centered on 2.0 kHz, the associated receiver can be operated at stabilized increments of frequency. For use with unmodified older TTY terminal units, some receivers such as those of the AN/WRC-1, AN/URC-32, and AN/URC-35 employ BFO (carrier) injection only at the dial frequency and therefore the tuning cannot be offset by the required 2550 Hz while the receiver is in a stabilized mode. For operation of the R-1051/URR receiver (Part of the AN/WRC-1) with 2550 Hz terminal units, the following procedure will be helpful:

1. The receiver "window" or reception passband is offset 1.5 kHz from the BFO (and the dial reading) by selecting the SSB mode. For single-channel RFCS, the mark/space relationships are correct when upper sideband is selected.

2. Switch the main tuning to VERNIER and set it for 3 kHz BELOW the assigned frequency. The R-1051/URR receiver frequency control is independent of the transmitter, which is set 2.0 kHz below the assigned frequency channel for RFCS operation.

3. Tune the incremental tuning to approximately 450 Hz and adjust as previously described for a appearance on the TTY converter scope.

This method of receiver tuning is preferable to the use of the CW mode because of the higher stability of VERNIER tuning and the better selectivity of the SSB mode. Using the receiver in this manner also provides better CW reception than that of the CW mode for the same reasons. The R-1051/URR bandwidth is 7 kHz in the CW and the AM modes, and 3.2 kHz in the SSB mode. The narrower selectivity in the SSB mode provides approximately a 2-to-one improvement in signal-to-noise ratio.

Because the AN/URC-32 uses only one stabilized oscillator for both transmitting and receiving, it cannot be used in the transceive mode with a 2550 Hz TTY converter. (EIB 644, NCB 112)

c. AFCS RATT NETS

AFCS terminal units of the AN/SGC-1 series and the newer CV-2460/SGC are reliable and "nettable" items of the ship's TTY system. They are versatile equipments ideal for ORESTES nets within a task group or task unit. For this reason, shipboard operators and technicians should understand their use and features in order to get the most from them. There is no better way to learn the capability of an equipment than by actual operation. This can be done easily by operators who want to become proficient, using an authorized UHF drill frequency.

The AN/SGC-1 and the CV-2460/SGC series AFTS terminal units are DC-to-audio converters in the transmit mode. They receive DC from a teletype loop and convert it into audio frequencies for modulation of a radio transmitter (note: the transmitter must be in the VOICE mode, not MCW mode). For

narrow audio frequency shift the high audio tone is 700 Hz and the low tone is 500 Hz. For wide shift (CV-2460/SGC only) the high tone is 2425 Hz and the low tone is 1575 Hz. Normally the high tone indicates a mark and the low tone indicates a space, but this relationship can be reversed at will.

In the receive mode the equipments are audio-to-DC converters. Audio from a receiver is fed into the terminal unit. The signal could have been transmitted either as AFTS or RFCS, as long as the receiver converts it to the proper tones.

Each terminal unit has a mode selector switch which can place it in constant XMIT or constant RCVE, or an AUTO position which permits it to switch to receive whenever a signal arrives from the receiver or go to transmit, keying and modulating the transmitter, whenever the local TTY keyboard is operated. This is ideal for net operation. The CV-2460/SGC has full duplex capability, permitting simultaneous use of transmit and receive functions.

The AFTS terminal units interface with other equipments via three basic inputs/outputs other than the AC power connection:

1. A DC circuit which is looped through the TTY patch panel.
2. An audio input into which a receiver feeds tones.
3. A keying and modulation output by which the terminal unit controls a transmitter.

The equipment is very simple to use, and will function effectively provided that compatibility is maintained with the other parts of the system. The first point of concern is adjustment of the receiver that is used to receive the radio signals. If the output of the receiver is noisy when no actual signal is being received, the noise will trigger the terminal unit into a RCVE condition and it will not go automatically into the XMIT condition when the local teletype keyboard is operated. The noise output of the receiver must be kept low or squelched off during the time no signal is being received. Ideally, the no-signal noise level should be about -30 dB when the receiver output is set to supply audio tones at 0 dB. Noise from the receiver must not be allowed to trigger the terminal unit into a RCVE condition when no tones are being received. The second point is based on the transmitter modulation level that has been set on the ship. If all radiophone remotes are set to furnish -10 dB modulation level into the transmitter speech amplifiers, and the audio output of the AFTS terminal unit is set to furnish 0 dB, overmodulation will occur which will cause distortion and interference. If the output of the terminal unit is set for less than the standard RPU modulation output, undermodulation will occur which will decrease the reliable communication range between ships. If the transmitter has a clipper-filter in its speech amplifier, this circuit should be turned off for tone operation; AGC (or AVC) circuits should be left on. The audio input and output levels from the TTY terminal unit should be set to furnish the same levels into the audio distribution system that the remote phone units furnish. Refer to Transmit-Receive Panels and Remote Control Units under Subsection 1-9.

Don't overlook the "spread" between mark and space frequencies; 700 Hz and 500 Hz for narrow shift AFTS gives a spread of 200 Hz. The normal spread for single channel RFCS in the low frequency

bands is 170 Hz. Either terminal unit can be used to copy narrow-shift RFCS of the type used on low frequencies when the associated receiver is set up properly. Just tune up the receiver to the desired signal as previously described in Tuning in A Single Channel RFCS RATT Signal, except that the receiver BFO is offset by -600 Hz rather than 2000 Hz (or 2550 Hz). The audio output from the receiver will be near enough to 700 Hz for mark and 500 Hz for space that the terminal unit can copy it. The CV-2460/SGC provides the additional capability of being able to copy wide shift RFCS single-channel circuits.

Either AFTS terminal unit can also serve as a part of single-channel UHF-to-HF relay circuits. It converts the AFTS signals received on UHF into a keyed DC loop current, and the loop current in turn operates the wide-shift RFCS circuits of the HF transmitter. Care must be exercised if the terminal unit and the HF transmitter have separate loop power supplies. The two power supplies must not be patched together. If such a risk exists, one solution is to wire the terminal unit to a miscellaneous jack on the TTY patch panel rather than to a looping jack. It can then be patched into either loop as required.

When the receiver input levels and the modulation output levels are properly set, and the mark and space frequencies are correct, the AN/SGC-1 and CV-2460/SGC series terminal units will provide reliable and versatile communications. (EIB 737, 741)

d. ORESTES NET

Many of the difficulties encountered on TF/TG ORESTES nets can be attributed to off-frequency situations between ships on the net. From measurements taken on an AN/URA-17 converter, it was determined that a frequency error in excess of 300 Hz introduces distortion to a received signal. A frequency error at 500 Hz makes most received signals unreadable because of excess distortion. Since these frequency errors can be shared by transmitter and receivers, a limit of 150 Hz of tuning error is established for either transmitter or receiver.

ORESTES nets with ASW aircraft or with Marine Corps units have additional requirements for transmitter accuracy because of compatibility considerations. The mark-space frequency accuracy for working with ASW aircraft is ± 20 Hz at the assigned frequency. For operation with Marine Corps units, this accuracy requirement is increased to ± 15 Hz.

It is imperative that absolute frequency control be practiced by operator/maintenance personnel. Many of the equipments in the Fleet today, although design for synthesized operation, have been long neglected. Since equipments can be operated in the continuous mode, it is common practice to operate in this manner. We pay for this malpractice by accepting poor copy and inordinate delays in passing traffic on nets using this method of communications.

A large percentage of ships have AN/URQ-9/10 frequency standards aboard but improperly utilized. The following equipments are designed for almost absolute highly specialized, highly accurate, frequency control, and indeed are capable of highly accurate control if operated and maintained properly.

AN/WRT-2	AN/WRR-2
AN/URC-32, 35	AN/URT-23
R-1051/URR	AN/WRC-1

Unless these equipments are operated in their stable (synthesized) modes, their dial accuracy may be so far in error (up to 7 Hz) that netting of crypto-covered teletype nets is often impossible. (EIB 714)

e. MULTI-CHANNEL TERMINAL EQUIPMENT

Multiplexing is the term used to define the art of combining more than one channel into one composite channel or trunk so that more than one message at a time can be sent on one transmitter. Multiplexing is usually shortened to the term "MUX" by radiomen. The multi-channel broadcast is a good example of "MUXING" and "DEMUXING." The ship utilizes equipment at the receiver end of the broadcast to "DEMUX" the signal into the individual channels.

Multi-channel broadcasts and ship/shore terminations utilize frequency-multiplexing, whereby each channel of the composite tone package of the broadcast or termination is assigned an audio frequency. The lowest audio frequency used is 425 Hz and the highest frequency used is 2975 Hz. The audio tones for the channels are 170 Hz apart and hence, there are tones at 425, 595, 765, 935, 1105, 1275, and so forth. There are 16 tones between 425 and 2975 Hz that are used. This gives a capability of 16 separate channels of intelligence under conditions.

In order to give ships more reliability in receiving a multi-channel broadcast, the shore station "twins" two channels and keys them with the same channel intelligence. Channels are keyed with the same intelligence to overcome "selective fading" and to give the receiving station two chances of getting the signals at one time. The twinning process uses frequencies separated by 1360 Hz to overcome the possibility of selective fading causing hits on the circuits. Intelligence from one channel is used to key 425 Hz and 1785 Hz channels or tones simultaneously. The ship receives both of these tones and converts them to DC to operate a teletype machine from the best of the two signals. The unit that combines the two signals is called a combiner unit, not similar to the comparator unit in an AN/URA-8. The theory is that if one tone (425 Hz for instance) fades out for an instant, the other tone (1785 Hz) might be loud and clear. Other tones are twinned for other teletype channels, such as 595 Hz and 1955, 765 Hz and 2125 Hz, and so forth. This limits the 16 tones in most MUX/DEMUX equipments to eight channels of intelligence, but gives better reliability by overcoming some of the effects of selective fading. Utilizing two frequencies in this manner is referred to as frequency diversity.

Another form of frequency diversity is available to the ships in both ship/shore terminations and broadcast reception. On the broadcast, there are many frequencies (transmitters) on the air with the same composite package of tones for the ships to receive. The ship can tune receivers to two of these frequencies and feed both sets of audio tones in the DEMUX equipment (AN/UCC-1). This gives the equipment two separate audio inputs (from two different transmitters on two different frequencies) to help maintain a good solid signal into the AN/UCC-1. Frequencies should be selected which are as close together as possible, such as an 8 Hz and a 12-Hz frequency or a 12-Hz and a 17-Hz frequency. Frequencies that are wide spread (such as 4 Hz and 17 Hz)

should not be used for normal operation of the DEMUX equipment. There may be a sufficient time delay, between the signals from these two transmitters in reaching the ship that added distortion may be added to the circuit within the combine units of the AN/UCC-1.

Only the lower frequency audio tones are transmitted on the low frequency portion of multi-channel broadcasts, because of limitations of antenna bandwidth and the bandwidth of the transmitter itself. These tones are from 425 Hz to 1615 Hz. There is no tone diversity (frequency diversity within the tone package) available. This is not a great hindrance, however, in that selective fading is not normally encountered on low frequency transmission paths.

Ship/shore termination equipment utilizes the same equipment as the multi-channel broadcast, except that the shipboard equipment has a send capability as well as a receive capability. The same operation exists on a multi-channel (VFTG) ship-shore termination as with multi-channel broadcast. There is one slight difference, and this is an asset in circuit reliability. The shipboard operator controls the frequency of the shore transmitters by requesting the two frequencies at which the shore transmitters shall be operated. The operator can choose two frequencies that are very close together and, hence, will assure the same propagation path from the shore transmitter to the ship. This condition gives very good frequency diversity and the ship should experience extremely good reception.

Reception on the ship of any tone diversity tone package can be good without utilizing the tone diversity. If one of the audio tone channels is bad in the AN/UCC-1 equipment, the output signal of the two audio channels involved may be so highly distorted that it cannot be copied. In this case, when one intelligence channel is unreadable or highly garbled, and the other channels of the ship/shore termination or the multi-channel broadcast are good, some remedial action can be taken. A technician on the ship can "untwin" the channels concerned and the operator can try the individual channels and sometimes copy the signal "fiver" on one channel.

MUX and DEMUX theories are not difficult and, if the shipboard operator becomes familiar with the concept of sending more than one intelligence at a time, he can isolate troubles and get good reception in most cases. (EIB 716)

f. SHIP/SHORE MULTIPLEX TERMINATIONS

Ship/shore multiplex terminations were measured aboard the USS ELDORADO. The parameters examined and recorded were: frequency of the carrier, tone frequencies, relative carrier output (when present), and bias distortion.

Continuous samples were taken during the course of the exercise. Almost without exception, it was found that the shore stations were on the correct frequency and well within tolerance. Numerous readings were measured on 45 different A2/A3 frequencies. Of these, only four frequencies can be transmitted from shipboard transmitters in a fully synthesized mode. In order to transmit in a synthesized mode, the carrier frequency must be in an even increment of 1 kHz. Of those measured, none were within tolerance. The average error was 152 Hz. This indicates that the equipments either cannot be operated properly, or that operations are choosing the wrong mode of operation.

The solution is obvious. Maintenance personnel must restore the equipment to designed operating standards, and operators must choose the correct mode. Present instructions (COMFIRKST-FLTNOTE 2400 of 31 October) dictate that all A2 and A3 transmissions will be made in a synthesized mode.

Figure 1-9 indicates that only 30% of the transmissions showed proper selection of carrier. Some of these were too far out of tolerance to permit synthesized reception of signals. The remaining 70% indicate either personnel error or equipment malfunction. Figure 1-10 indicates equipment accuracy. Transmitter and receiver frequencies which differ by more than five hertz result in degraded copy. Beyond ten hertz differences, the termination is useless. Note that 40% of the transmission were beyond limits and required AFC controlled receivers which require that a pilot carrier be transmitted in addition to the tones. This results in improper mode of transmission, and also utilizes power which could otherwise be conveying intelligence.

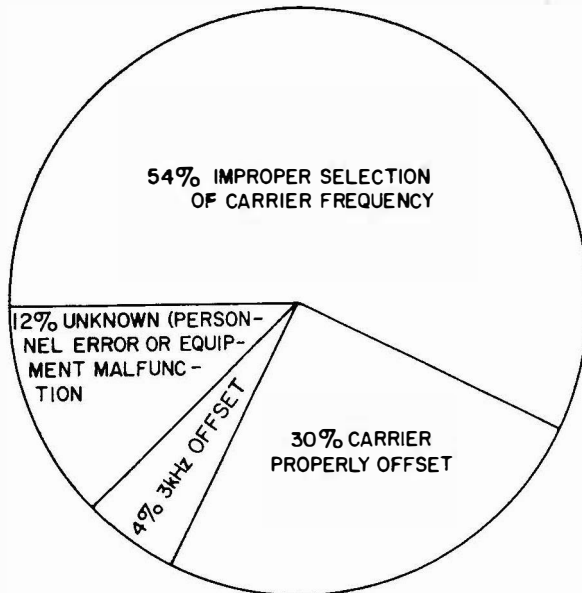

Figure 1-9. Selection of Proper Carrier Frequency Variable Frequency Tone Group (VFTG)

g. TONES AND VFTG CIRCUITS

The tones generated by an AN/UCC-1 VFTG send terminal, or the AN/FGC-60 equivalent shore send terminal, cover the audio frequency range of 382.5 Hz to 3017.5 Hz. Normally, two tones are utilized for each intelligence channel to give close frequency diversity, thereby decreasing the effects of selective fading. The AN/UCC-1 then, normally has an 8-channel intelligence capability with 16 tones. The pairs of audio tones used on a given intelligence channel are separated by 1360 Hz.

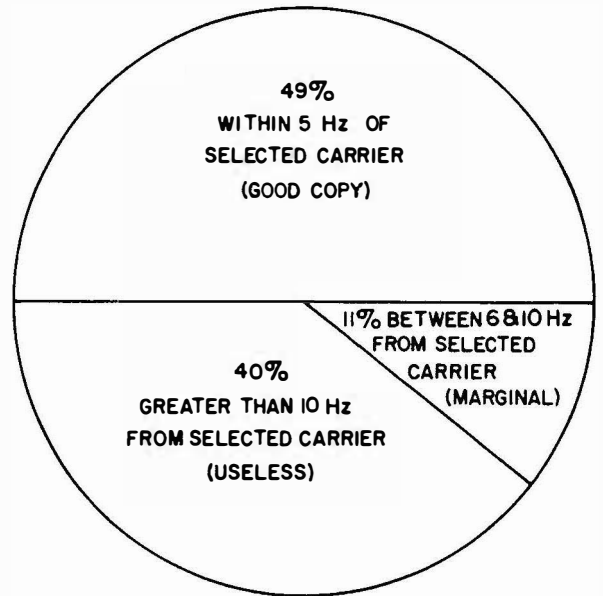

Figure 1-10. Frequency Accuracy of Transmitters (VFTG Terminations)

Because of limitations on crypto equipments, traffic handling capability, teletype machines, and personnel, a ship normally utilizes only four intelligence channels (eight tones). The remaining tones for the unused channels of the AN/UCC-1 serve no useful purpose.

The blocking mode of operation (sometimes called "idling") can often be employed in multi-channel operation over VFTG circuits to overcome slow fading, weak signals, or noise which may not permit operations in the twining mode. Blocking is accomplished by inserting dummy plugs into the tone equipment jacks or grounding the output of each separate transmit channel as required. By holding transmission on given channels, the transmitted power used in these channels is concentrated in the channels still in use. The number of channels blocked depends upon the conditions of the frequency or frequencies in use at the time.

CAUTION

When blocking or idling is employed, be sure to readjust the input levels to the transmitter to maintain peak output power. The transmitter output is directly related to the audio input power.

During periods of marginal communications, tones should be blocked to obtain the following advantages:

1. Slightly more power "per tone channel" can be transmitted without overloading the transmitter.

This is only a very slight increase in power and care must be given to ensure that the transmitter is not overdriven to the point that distortion takes place. Readjust levels at the AN/UCC-1 and check transmitter to ensure it is not being over modulated.

2. With fewer tones being transmitted the chances of shipboard generated radio frequency interference are decreased. Also, the chances of intermodulation distortion are decreased tremendously as far as the number of byproducts mathematically available are concerned.

3. Decreased bandwidth also lessens the chances of interference on other ships using adjacent channel operation. By blocking the higher audio frequencies from the tone package, a "guard band" is placed between this tone package and the next higher channel frequency. This causes less interference throughout the fleet.

If the front end (on the receiving end of the circuit) is driven into the non-linear area of conduction, the fewer tones in the tone package will result in fewer by-products being generated within the receiver.

Tone blocking should be practiced until it becomes normal operation. It makes good common sense to only transmit the tones that are used to convey intelligence and to block the unused tones.

It must be remembered that channels 1, 2, 3, and 4 are not the only channels that can be used for terminations. In some cases, it may be advantageous to utilize channels 5, 6, 7 and 8. Any combination of channels may be used. Untwining can also increase the number of channels available for ships that only have a four-channel capability. Initiative and a desire to communicate should be the guiding doctrine in the use of VFTG MUX equipment. (E1B 718)

h. TUNING MUX (MULTI-CHANNEL) CIRCUITS

Multi-channel circuits permit more than one channel of intelligence to be transmitted and received over one frequency. Only one transmitter and one receiver are necessary at each end. In ship/shore terminations, one additional transmitter and receiver are used to give better reliability, although one receiver will operate the circuit. In broadcasts, the shore station runs many frequencies in order to provide reception to ships all over the area of responsibility for that particular shore station.

The single channel radio teletype signal has a shift of 850 hertz and can be readily tuned in on practically any receiver with just a little care. If the audio from the receiver enters the teletype converter at slightly different frequencies than those for which the converter is designed, the circuit will probably operate QRK 5 anyway. In multi-channel (MUX) operation, the shift on each channel is only 85 hertz-one tenth the shift that single channel radio teletype circuits use. These circuits are much more critical and difficult to tune. The result of a frequency error on multiplex is ten times more critical than would be indicated by the difference in the amount of shift. As an example, a frequency error of 500 hertz on FSK will introduce approximately 5% distortion to the copied signal; a frequency error of only 5 hertz in MUX operation will introduce this same 5% distortion.

The package of tones that originates in the MUX unit ashore has 425 hertz as the lowest frequency tone, and tones are present every 170 hertz up the audio frequency spectrum, with a tone of 2975 Hz as the highest frequency audio tone. There are 16 tones for the 8 or 16 channels of intelligence that are normally transmitted on MUX circuits. These tones are transmitted as audio modulation to a single sideband suppressed carrier transmitter and are radiated as the upper sideband of the transmitter. Assume that the assigned frequency for radiation of MUX is 4905 kHz; the frequency is cleared for a three kHz bandwidth so the tone must straddle the center frequency or assigned frequency (4905 kHz) in this case). The tones occupy roughly 3000 Hz (3kHz) of the spectrum. In order to straddle the assigned frequency with these tones, the suppressed carrier on the transmitter must be placed 1.5 kHz below the assigned frequency. In the assumed case, the frequency assigned is 4905 kHz and the suppressed carrier is placed 1.5 kHz below that, or at 4903.5 kHz. When this suppressed carrier is modulated by the 425 hertz (lowest frequency of the MUX tone), the two frequencies are added, and that 425 hertz tone is radiated at a radio frequency of 4903.925 kHz (4903.5 plus 0.425). The highest frequency audio tone is 2975 Hz or 2.975 kHz and, when it is modulated in the transmitter, its output frequency becomes 4903.5 plus 2.975 or an RF frequency of 4906.475 kHz. The audio tones for the other channels are in between these two RF frequencies.

With suppressed carrier single sideband type of transmission, the receiver picks up the individual channel frequencies in one package, but has no carrier frequency in the package to use as a reference. The "carrier" frequency is actually generated and injected into the package of tones within the receiver on board ship. Tuning the receiver produces this injected carrier into the tone package and then the tone are detected (demodulated) and appear as audio. This is fed to the AN/UCC-1 equipment for conversion into teletype signals.

With the receiver on the correct frequency, listen to the audio and make sure that the frequency is clear, with little or no noise for interference. Try several antennas and patch cords to obtain the strongest and clearest reception possible. If the receiver has an antenna tuning device, be sure and peak this for maximum received signal. If the signal is extremely strong, decrease the amount of radio frequency gain so that the AGC action of the receiver will not distort the audio output to the receiver. Adjust the audio level out of the receiver to the correct level for the input of the device used to convert the audio tones to teletype signals. Normally, this will be an AN/UCC-1 equipment. Adjust the level out of the receiver after the patches have been made to feed the signals into the AN/UCC-1.

Keep a second receiver tuned in to another frequency on either broadcast or ship termination type circuits to give an instant back-up if one frequency fails or a transmitter goes off the air at the shore station. Keep an audio monitor on the two frequencies to make sure that they are both of traffic quality at all times. If one frequency goes bad, QSY the receiver to a new frequency before the other frequency also goes bad. If two signals are found of the same quality, the AN/UCC-1

equipment can be set up for receiving and comparing both of these frequencies in frequency diversity. In order to use this mode of operation, the AN/UCC-1 must be set up in accordance with the technical manual and, additionally, both frequencies must either be broadcast from the same transmitting location or locations that are the same distance from the ship.

Not all receivers on board ship will operate efficiently on MUX signals, as the receivers tend to drift in frequency. They will drift only a few cycles, but that may be enough to highly distort a circuit. The receivers commonly used now for MUX signals are the R-1051/URR, AN/WRR-2, and the AN/SRR-19. The AN/WRR-2 receiver cannot be used on frequencies where the carrier must be injected at half kHz points, unless Field Change I has been applied. The other receivers on board ship, such as the R-390/URR, are not suitable for MUX operation unless in an emergency.

The signal pulses on diversity channels (twinned pairs) must arrive simultaneously at the terminal equipment in order that the channels (4 on Quad Diversity) may be used in diversity operation. Errors in arrival time (1 to 5 milliseconds delay distortion) were introduced by the shore transmitting stations during operation BASE LINE II. Because of this delay, compensation at the receive MUX terminal should be made while receiving the desired station. The procedures in the AN/UCC-1 Technical Manual require that the transmit station send reversal type signals during alignment of the equipment with the test set provided. This procedure is not always possible, especially on broadcast circuits; however, the adjustment can be made while traffic is being passed by measuring delay between channels with a dual trace oscilloscope.

The signal pulses arriving at the KW-37 broadcast channel must arrive simultaneously with each of the pulses on the associated KG-14 channels for proper operation. The KG-14 has a variable delay switch which can be used to compensate for known delay differentials. The alternate procedure is to compensate for all delays at the MUX receiving terminal. It is not feasible for a shore broadcast station to transmit reversal type signals to permit adjusting channel delay with the test set provided with the AN/UCC-1 equipments. The adjustment or measurement of delay distortion must therefore be made while traffic is being passed by measuring delay between channels with a dual trace oscilloscope.

The difference is delay distortion between twinned broadcast channels and associated KW-37 and KG-14 broadcast channels should be fairly constant throughout each broadcast area. These delays will very likely be different between one broadcast area and another until broadcast stations develop procedures and equipment capability to standardize on synchronization. (EIB 719)

i. UHF/HF RELAY

The communications duties of destroyers include providing the carriers with UHF/HF relay, not only during HERO and RADHAZ conditions but for sustained periods of time. In the past, only the destroyers homeported in WESTPAC together with a few ships deployed to WESTPAC had worked out the details of VOX relay, and these "old reliables"

were perpetually asked by the carriers to perform relay duties. So many of the new arrivals lacked the ability to conduct a successful relay that the Fleet Commander called for command attention and insisted on performance. Henceforth each destroyer must not only demonstrate a relay capability commensurate with its existing transmitter installation but a proficiency in relay as well. Carriers have been asked to rotate the relay assignment among the destroyers attached and to report inabilities on the part of any of them. The carriers are beginning to realize that a 2100 ton class destroyer is incapable of providing the same degree of relay services as the DLG class because of the obvious disparity of equipment. However, this does not exonerate the 2100 ton class destroyer from demonstrating a proficiency in each of the modes if her communications installation includes the proper types, not numbers, of equipment.

Relay capability in each of the following modes should be established:

Single channel VOX relay Consists of converting UHF AM voice or tone-mode teletype signal to HF using the C-4621/SR retransmission unit.

Double channel simultaneous VOX relay Consists of converting two UHF AM or tone-mode (AFSK) teletype signals to an HF SSB voice or tone-mode teletype signal using the C-4621/SR unit.

Single channel VOX relay on single sideband Consists of converting an UHF AM voice or tone-mode teletype signal to an HF SSB voice or tone-mode teletype signal using the C-4621/SR unit.

Independent sideband two channel VOX relay Consists of converting two UHF signals, one voice and the other tone-mode teletype to one HF upper sideband voice and lower sideband tone-mode teletype using the C-4621/SR unit.

Composite (2 or 3 channel) MUX relay Consists of converting a UHF composite MUX signal to an HF composite MUX signal on a sideband using the C-4621/SR.

Single channel frequency shift teletype relay Consists of converting an UHF tone-mode teletype signal to a HF frequency shift signal using the AN/SGC-1A.

Diversity frequency shift teletype relay Consists of converting a single UHF tone-mode teletype signal to one HF frequency teletype and one MF frequency shift teletype signals using the AN/SGC-1A.

A MUX relay in frequency shift mode is difficult to manage because of the slow response of the mechanical relay in the AN/SGC-1A. An electronic relay replacement to remedy this deficiency is being considered at this time.

The most common error is the mistaken belief that the VOX (C-4621/SR) can drive a frequency shift keyer. The VOX unit can handle only audio signals and drive a modulator. However, the AN/SGC-1A teletype tone modulator can convert the tone-mode teletype audio signal into the mark and space bits to key the DC loop of a frequency shift keyer. Upon learning that the AN/SGC-1A is necessary to convert a tone-mode teletype to frequency shift, many ships find that they are unable to isolate the AN/SGC-1A in the teletype DC loop board. Both the frequency shift keyer in the transmitter and the tone modulator have their own DC loops, and

two power supplies won't work. There are several solutions to this problem but the one in COMFIRST-FLT TACNOTE 1-63 which suggests isolating the AN/SGC-1A in the miscellaneous jack is probably the simplest. Those ships that still have the TT-23 panel with its very versatile feature of the toggle switches don't have this problem.

Failure to modify the C-4621/SR as authorized by Field Change 1 to permit duplex operation limits the capacity of some ships.

Upon receiving a request from a carrier to relay a two or three channel MUX signal, several destroyers have originated messages to the TYCOM requesting that MUX equipment be installed at the earliest possible time so that this service might be rendered. MUX relay requires no MUX equipment. Successful UHF/HF relays of multiplex signals should use the following procedures:

Upon receipt of a condition one voice message on the COMM COORD net:

1. Inactivate clipper-filter circuits of the UHF transmitter.
2. Tune a UHF receiver to frequency designated.
3. Tune AN/WRT-2 or similar transmitter as follows:

NOTE

AN/URC-32 is not considered acceptable for relay

- Step a. Tune transmitter as usual to frequency designated in condition message.
- Step b. Set EMISSION selector to USB.
- Step c. Set CARRIER REINSERT to -10 dB or as indicated in condition message.
- Step d. Set SIDEBAND SELECTOR to sideband indicated in message.

4. Patch UHF receiver to transmitter VOX control C-4621/SR.
5. Patch AN/WRT-2 or other transmitter to transmitter VOX control C-4621/SR.
6. Transmit condition one voice message

Upon receipt of condition three voice message:

1. When tones are heard in UHF receiver, adjust its audio output to ± 2.5 dB. THIS LEVEL MUST BE MAINTAINED.

2. Adjust transmitter mode level on transmitter control C-4621/SR to zero dB on level meter.

3. On transmitter, lock on carrier test key and adjust audio output of previously designated sideband.

4. The AN/WRT-2 should now indicate approximately 120 watts on the output meter.

Periodic checks and adjustments of the UHF receiver audio output are necessary to compensate for the effects on signal strength and distortion when changing bearing and distance to the ship of signal origin. (EIB 741)

1-6 TRANSMITTING EQUIPMENT

Transmitting equipment includes RF sources and modulators, in addition to transmitters. The simplest practicable transmitter for CW transmission consists of a power supply, an oscillator, an RF amplifier, as shown in the block diagram of Figure 1-11. A more typical transmitter, with heavy lines showing the functions required for CW operation, is shown in the block diagram of Figure 1-12.

A CW transmitter can be transformed to a radiotelephone, or phone, transmitter by the addition of a modulator, shown in dotted lines in Figure 1-12. Although the modulator, frequency source, and power supply are usually parts of the transmitter, typical malfunctions involve only one of these at a time. Troubleshooting them is simplified because the malfunctioning section of the equipment can be troubleshot as a separate equipment, aside from power requirements. Preliminary troubleshooting procedures are given first and then procedures for transmitters, RF sources, and modulators, which are followed by procedures for single-sideband transmitters. Power supply troubleshooting procedures are given in Subsection 1-7.

a. MALFUNCTION INDICATION

Navy transmitting equipment is provided with meters to enable each equipment to serve as its own test equipment. By using them, the technician can determine what area of the circuitry can be responsible for a given malfunction. These indications are used extensively in the troubleshooting procedures following and enable much equipment performance to

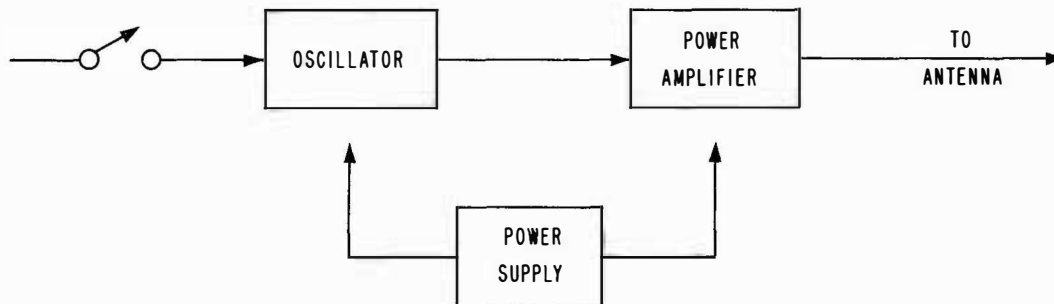

Figure 1-11. Simple Transmitter, Block Diagram

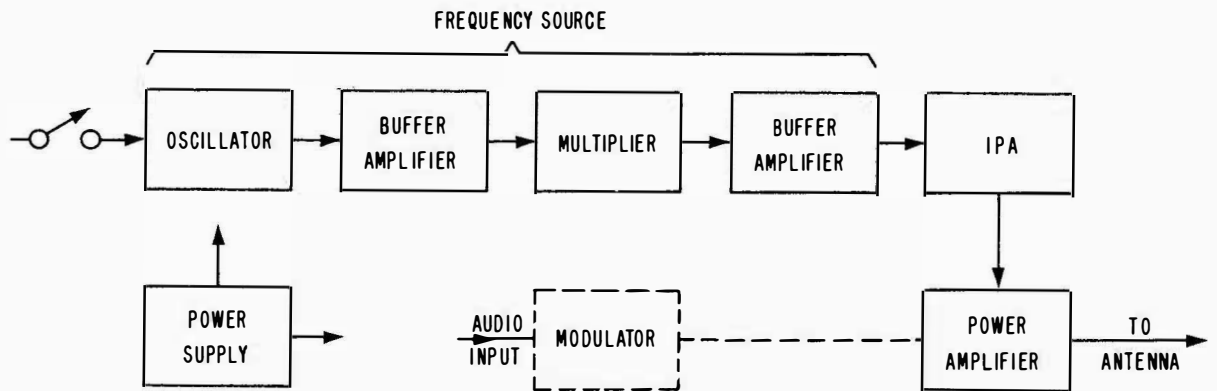

Figure 1-12. CW and Phone Transmitter Block Diagram. (Components Needed for CW Operation in Solid Lines).

be evaluated without removing a chassis from the cabinet.

b. PRELIMINARY TROUBLESHOOTING PROCEDURE

Perform the appropriate steps in the following procedure if the approximate location of the malfunction is unknown. Use of this procedure will result in the correction of the malfunction or identification of which procedures to use in further troubleshooting.

Step	Indication	Action
a.	Transmitter gives no indication of being energized.	Verify that power switch is in correct position. Check line cord and plug for condition and correct insertion. Check the fuses and replace blown-out ones.
b.	Transmitter is energized but correct operation is not obtained.	Verify that all dial and switch settings are correct. If panel meters do not indicate the presence of the correct power supply voltages, use the power supply troubleshooting procedures of Subsection 1-7. At this time, determine in what way and on what functions (CW, SSB, PHONE, etc.) operation is impaired. Determine if it affects only certain bands or channels. Further define malfunction as

Step	Indication	Action
		no operation, operation at reduced power, inability to tune or load at a required frequency, inability to modulate properly, etc.
c.	Malfunction found only on one band or channel.	Inspect bandswitches for correct action in operation and proper adjustment and clean contacts; clean, adjust, and replace as needed to obtain correct operation. The visual inspection with equipment deenergized should be followed by a measurement of all voltage values affected by switching with equipment energized. Inspect and test components and connections switched in when malfunctioning band or channel is selected. If this is not effective, set the equipment to the malfunctioning band and continue with Step d.
d.	Malfunction found only on one function (or several related functions).	Inspect all function-selection switches for correct operation, proper adjustment, and clean contacts; clean adjust, and replace as needed to obtain correct operation. If this is not effective, inspect the condition of and test the operation of all circuitry switched into the circuit in the malfunctioning

Step	Indication	Action
		positions. This will include, for example, STANDBY, TUNE, PHONE, LSB, etc. If this is not effective, set the equipment for the malfunctioning operation and perform the following procedures where appropriate.
e.	Transmitter cannot be tuned to a desired frequency.	If no IPA drive is measured or if the frequency source cannot be tuned, follow the troubleshooting procedures of Subsection 1-6, RF, Oscillator or Frequency Source Malfunctions. If the IPA cannot be tuned, follow the instructions for Subsection 1-6, Transmitters. If the PA cannot be tuned or loaded properly, follow the instructions for Subsection 1-6, Transmitters.
f.	The ANTENNA CURRENT meter indicates the presence of a carrier but does not indicate any power due to modulation.	If the MODULATOR CURRENT meter reading is normal and fluctuates with variations in input, perform Step b of Subsection 1-6, Modulators. If the MODULATOR CURRENT indication is abnormal; if modulation contains hum, distortion, or noise; or if undermodulation occurs, follow the appropriate steps of Subsection 1-6, Modulators.

It is assumed that this or a similar procedure will be used to determine the approximate location of the malfunction and the appropriate steps to determine the approximate location of the malfunction and the appropriate steps to be used of the systematic troubleshooting procedures following.

c. TRANSMITTERS

Perform the appropriate steps in the following procedure if the malfunction is thought to be in the transmitter IPA, PA, or following (coupling and antenna) circuitry. Test transmitter operation following any change (repair, replacement, or adjustment) to ascertain if normal operation has been restored.

NOTE

In testing tubes, return each good tube to its ORIGINAL socket after testing. Replace defective tubes but keep in service tubes that test slightly low. Test-substitute a new and tested-good tube for one of questionable condition, but return it to stock and the old tube to the socket if the substitution does not improve the performance of the equipment.

CAUTION

Observe all safety precautions, being sure to deenergize the equipment before removing a chassis and to discharge all filter capacitors before working on a chassis. In making resistance measurements, discharge all capacitors that could affect measurements or damage the ohmmeter.

Step	Indication	Action
a.	PA PLATE CURRENT is not normal.	Verify that all dial and switch settings are consistent with known preliminary of calibrated settings. Verify that the IPA grid drive can be adjusted properly and then make the following adjustments. IPA tank, PA EXCITATION or GRID DRIVE, PA TUNING, AND LOADING.
b.	PA PLATE CURRENT is not normal, but PA GRID DRIVE is normal.	Test-substitute new PA tube(s) and try retuning. Test substitute dummy antenna at transmitter output or new transmission line and new antenna. Inspect and, where necessary, clean and adjust tank and coupling circuitry, switches, and antenna relay. Test-substitute new coaxial links if malfunction continues.
c.	IPA GRID DRIVE and PLATE are normal but PA GRID DRIVE or GRID CURRENT are abnormal.	Test-substitute new PA tube(s) and test transmitter operation. Return original tube(s) to equipment if substitution does not improve operation. Inspect and, if necessary, clean and adjust contacts of all associated switches. Test condition of all components in network between IPA and PA stages.

Step	Indication	Action
d.	IPA GRID DRIVE normal but IPA PLATE CURRENT abnormal.	Test-substitute new IPA tube(s); return original tube(s) to equipment if substitution does not improve operation. Determine the condition of all switches and other components associated with IPA stage, especially in resonant network, coupling it to PA input.

(1) RF Oscillator or Frequency Source Malfunctions

Use the appropriate steps in the following procedures to correct any malfunctions in the RF oscillator, whether crystal-controlled or LC-controlled.

Due to the wide variety of configurations and circuits used in RF oscillators, the following troubleshooting steps have been broken down to cover specific conditions rather than type of equipment. The malfunctions covered are no RF output, low RF output, and off-frequency RF output. Frequency synthesizers are so complex and of such differing configurations that this chapter does not attempt to give a troubleshooting procedure for them. The general steps that apply to them, as well as to all other electronic equipment, are given in this section; the ET is referred to the appropriate technical manual for detailed troubleshooting procedures.

(2) RF Output is Unsatisfactory on Only One Band or Channel

Use the following steps if a malfunction of any kind is experienced on one band, or one or a few channels, in the operation of a band-switching or channel-switching frequency source.

Step	Indication	Action
a.	Impaired operation on one (or a few) bands or channels, characterized by no, low, or off-frequency output.	Inspect action of band- or channel-switches visually (equipment deenergized) and electrically (equipment energized). Verify that switching action is correct. Clean and adjust contacts.
b.	Same as Step a, except switching action acceptable.	Test-substitute new oscillator tube. Also, if frequency is crystal-controlled, test-substitute new crystal of similar frequency.
c.	Same as Step a, except switching, crystal, and oscillator tubes presumed good.	Verify (by VTVM or oscilloscope) that oscillator stage has no output on malfunctioning band or channels. Make oscillator socket voltage and resistance measurements; compare values found with normal ones given in

Step	Indication	Action
d.	Same as Step a, except switching, crystal, and oscillator tubes presumed good.	the technical manual to identify possible defective components; replace any defective components. If the previous steps have been ineffective, set band switch or channel selector to a malfunctioning position and follow troubleshooting steps appropriate for the type of malfunction encountered.

(3) RF Output is Absent from Frequency Source

Use the appropriate steps among the following if no RF from the frequency source is found at the IPA stage.

Step	Indication	Action
a.	No RF present at IPA stage.	Use an oscilloscope or wave-meter to verify that the desired RF is not present at the input to the IPA or at the output of the frequency source. Check continuity of cables, connectors, and switches if it is present at the frequency source output but not at the IPA.
b.	No RF present at output of frequency source.	Test all tubes of frequency source on a transconductance tube checker. Discard those tubes which show a transconductance value less than half of the normal value or have internal short circuits. Return each acceptable tube to its original socket and replace discarded tubes with tested-good ones.
c.	No RF output from frequency source; tubes good.	Test-substitute a new crystal of a nearby frequency for each crystal in the frequency source.
d.	No RF output from frequency source; tubes and crystals good.	Use a VTVM or an oscilloscope to trace the RF signal from the oscillator to the point where it cannot be found. Start with the oscillator plate and trace the signal to each following plate. When the signal is lost at a

Step	Indication	Action
		plate, determine if it is present at the grid of that stage; if not, it is lost in the resonant and coupling circuitry preceding. If the RF signal is found at the grid, it is lost at the tube; substitute a new tube and make tube-socket voltage and resistance measurements to components found.

(4) Output of Frequency Source is too Low in Amplitude

Use the appropriate steps among those following if the RF output of the frequency source is too low in amplitude to drive the IPA properly.

Step	Indication	Action
a.	RF output of frequency source too low in amplitude.	Test all tubes of frequency source and any associated in the power supply on a transconductance tube checker. Discard those tubes which show a transconductance value less than half of the normal value or have internal short circuits. Return acceptable tubes to their original sockets and replace discarded tubes.
b.	RF output of frequency source too low in amplitude, but tubes good.	Use the techniques of Step d RF Output is Absent from Frequency Source, to identify any amplifier stage failing to produce the required gain or any other stage causing undesired attenuation. Some loss should be expected in passive circuitry (RF transformers and networks), but amplifiers and multipliers should show some gain. Cathode followers should show a slight voltage loss.
c.	Abnormal attenuation found in an RF transformer or resonant circuit.	Disconnect the suspected components from the circuit and test. Verify that the Q in inductors or assembled networks is within reasonable

Step	Indication	Action
		limits - under no circumstances below 10. Test suspected components by replacing them in the circuit.

(5) Output of Frequency Source is Off Frequency

Note that the following steps are identified as being appropriate for large and small frequency errors, respectively. Large errors are considered to be those producing output at the second harmonic and above. Use the appropriate steps for the magnitude of the frequency error; note that small errors may remain after the large ones have been corrected.

Step	Indication	Action
a.	Frequency source output apparently in error.	Use a frequency meter series or equivalent to determine the output frequencies. Determine from this data the magnitude and extent of the errors, their amount, and what band or channels they influence.
b.	Frequency source output is a harmonic of the indicated frequency.	Retune the frequency source, starting each adjustment from its low-frequency extreme (capacitor fully enmeshed) and peaking or dipping it at the first indication of resonance.
c.	Frequency source output is a harmonic of the indicated frequency.	Determine for a test setting what should be the frequency of the signal at each stage of the frequency source. Measure the frequency at each stage with a frequency meter and compare the measured and computed values for each stage to determine where the undesired harmonic originates. Determine the condition and Q of the resonating and filtering components involved. Make tube socket voltage and resistance measurements at that stage to locate any components resulting in incorrect operating conditions.
d.	Undesired frequency multiplication occurs in	If the basic frequency is crystal-controlled, test-substitute known

Step	Indication	Action	Step	Indication	Action
	frequency source; all components apparently in good condition.	good crystals of the same or nearby frequencies. If this is not effective or applicable, try the following changes, in order: 1. Test condition of frequency-controlling or filtering components. 2. Place a tube shield around the oscillator tube if it does not already have one. 3. Place experimental shielding around oscillator stage circuitry. Check lead dress, particularly if it appears to have been altered. 4. Determine the condition of all filament and screen bypass capacitors at frequency source stages. Add them, where not already included in the circuitry, between these points and ground; disk ceramic capacitors of 0.005 pF and a high enough voltage rating for the specific application are satisfactory.		any type of frequency source.	ambient temperature and cabinet or console placement permit correct cooling. Correct any conditions responsible for poor cooling.
e.	Frequency error is relatively small and originates at oven-enclosed crystal.	Check oven thermostat and heater operation. Monitor heater current and oven temperature, if necessary to verify that current is at a maximum value until output temperature is reached, following which it is intermittent and cyclic around an equilibrium value. Make adjustments for correct equilibrium temperature, if necessary and possible, or replace any defective components - thermostat, heater, or entire assembly, if necessary.	g.	Frequency error is relatively small; equipment cooling is satisfactory.	If output is crystal-controlled, test-substitute a known good crystal for the original one. If this is not effective (or in LC-controlled equipment), make oscillator socket voltage and resistance measurements to locate any components that may be causing incorrect tube operating conditions. Replace any such components.
f.	Frequency error is relatively small and originates at	Verify that the transmitter blower (if provided) is operating and that the	h.	Frequency error remaining is small enough to be due to cumulative results of component aging.	Make calibration adjustments on oscillator trimmer capacitor, using an accurately calibrated LR-series frequency meter as a standard. LC-controlled channels are calibrated by alignment of one of the resonant components. Each continuously variable band is calibrated by a trimmer capacitor at the high frequency end and a padder capacitor or variable inductance at the low frequency end. The appropriate technical manual for the equipment gives detailed alignment and calibration adjustments in each case.

(6) Frequency Errors Originating in Frequency Synthesizer

Many newer transmitting equipments provide frequency selection by switch control of a frequency synthesizer. This provides for mixing the desired outputs of harmonic generators and frequency dividers, which are driven by a stabilized master oscillator. Since this equipment is complex and takes many forms, it is suggested that the ET called on to service it perform only Steps a and b. Step c and d should not be performed by shipboard personnel except in case of emergency. Steps c and d normally should be performed by tender personnel or a shore facility.

Step	Indication	Action
a.	Output of frequency synthesizer known to be off frequency.	Test all tubes on a transconductance tube tester. Tubes having a transconductance at least half of the normal value and no internal shorts should be returned to their original sockets. Replace all other tubes with new ones.
b.	Frequency synthesizer known to be off frequency; tubes known good.	Make tube socket voltage and resistance measurements to locate defective components that alter operating conditions; replace such defective components.
c.	Frequency synthesizer known to be off frequency; tubes and operating conditions known acceptable.	Use an accurately calibrated frequency meter to compare the synthesizer output with the frequencies indicated by its control settings. Tabulate the amount of the error for each frequency at which error is found. Then use the equipment schematic or block diagram to locate the stages which could cause the errors noted. This is an analytical process, two examples of which follow. Example 1: Condition: Signals with 900 kHz in their frequency designation (1.900 to 1.999 MHz, 2.900 to 2.999 MHz, etc.) are all supplied 100 kHz low. Stipulation: The 900-kHz component is supplied by a single frequency divider. Conclusion: Malfunctioning of this divider could result in the error noted. Example 2: Condition: Frequencies containing odd multiples of 1 MHz are supplied 1 MHz low in the output, duplicating the lower even-multiple range (1.9 MHz being supplied as 0.9 MHz, for example). Stipulation: Odd multiples of 1 MHz are

Step	Indication	Action
d.	Frequency synthesizer known off frequency; possible sources of error indented.	obtained by addition of 1.0 MHz to the appropriate even multiple. Conclusion: Any stage generating or handling the 1-MHz signal could cause this error. Set frequency synthesizer for a known erroneous output. Determine what frequencies should be present in each of the potentially defective stages. Use the frequency meter or frequency selective voltmeter to measure the frequency present in each of these stages until the malfunctioning stage is found. Make tube socket voltage and resistance measurements at this stage and replace any defective components found in this manner. If the defective stage functions as a frequency divider or multiplier, make the time-constant or resonance adjustments given in the equipment's technical manual for this stage, whether component replacements are made or not.

(7) Frequency Control Circuit Malfunctions

Frequency control circuits are included in some RF sources to lock the basic frequency setting so that one of its derivatives coincides with a derivative of a reference frequency. This circuitry may be located in a hermetically sealed and temperature-controlled enclosure. Because of the complexity of the circuitry, the technician is advised to perform the following steps first in case of malfunctions, performing the procedures given in the technical manual for the equipment only in case of emergency or if he has experience with this equipment.

Step	Indication	Action
a.	Frequency control circuit malfunctioning.	Test all tubes of frequency control circuit on transconductance tube tester, returning to their original sockets those tubes showing a transconductance at least 50 per cent normal and having no internal shorts

Step	Indication	Action
b.	Frequency control circuit malfunctioning; tubes in good condition.	Make tube socket voltage and resistance measurements to locate any defective components; replace any found. Note that procedures in the appropriate technical manual must be followed in establishing conditions for the measurements.

d. SINGLE-SIDEBAND TRANSMITTERS

Only one side band and no carrier (normally) is used for single-sideband (SSB) transmission. Specialized modulating and transmitting equipments are needed for this type of transmission. Some transmitters have been modified for SSB transmission, but all new SSB transmitting equipment is in the form of transmitters, rather than adapters.

(1) Theory of Single-Sideband Transmission.

Several methods of obtaining SSB modulation have been devised, the most common one (Figure 1-13) using balanced modulators (Figure 1-14). Such circuitry and the heterodyning procedures used differentiate SSB transmitters from conventional A3 transmitters. The first balanced modulator shown in the example mixes audio (voice) with a 1.5 MHz RF signal to obtain only the sum and difference frequencies

in the output. The narrow-band filter removes the lower sideband, passing only the sum frequencies. The oscillator and intermediate frequencies are specified in equipment design to facilitate sideband selection in the first filter and pass any of the desired RF output frequencies through the second filter. The amplifiers used in this circuitry must be linear amplifiers—class A, class B, or a combination - as opposed to the class C stage commonly used as the power amplifier for A3 transmission.

All techniques for generating a SSB signal are similar in that the audio component is heterodyned with an RF signal at a relatively low power and frequency level. Therefore, mixing (heterodyning) rather than multiplication techniques must be used to obtain the final radio frequency.

(2) Single-Sideband Adjustments.

Single-sideband techniques depend on the accuracy and stability of oscillator and filter adjustments. These and modulator balance adjustments should be made, if necessary, after replacement of an oscillator or modulator tube.

The adjustments found in SSB transmitters, along with the purpose of each and the method of determining correct adjustment, are listed in Table 1-5. Not all of these adjustments are found on every SSB transmitter, but many of them, plus the conventional transmitter drive, tuning, and loading adjustments, are part of every SSB transmitter. The letter designating each adjustment is given in Figure 1-13 to show where the adjustment is located and also in referring to them in the troubleshooting procedure. The unlettered adjustment of carrier reinsertion amplitude is found only in Independent Sideband (ISB).

TABLE 1-5. TYPICAL SSB ADJUSTMENTS

Adjustment*	Adjustment of	Effect of Adjustment	Correct Adjustment Indication
A	Audio input level	Permit desired RF output	AC voltage at input
B	First Injection frequency	Permit retention of desired sideband and determine output frequency	Calibrated receiver or frequency meter at buffer amplifier output
C	First Injection signal amplitude	Permit optimum power-handling and output	RF voltage at balanced modulator input
D	First modulator balance	Minimize carrier in output	Calibrated receiver or field strength meter
E	Sideband rejection filter bandpass	Pass desired sideband and reject other	Calibrated receiver or field strength meter
F	IF buffer amplifier output level	Permit optimum power-handling and output (control sideband power in ISB operation)	AC voltage at buffer amplifier output
G	Carrier reinsertion amplitude	Control pilot carrier amplitude	Calibrated receiver or field strength meter
H	Second Injection frequency	Determine output frequency—may be calibration for band tuning or adjustment for channel selection	Calibrated receiver or field strength meter
I	Bandpass filter	Rejection of undesired frequencies	Sweep generator and receiver, or receiver
J	RF output amplitude	Permit optimum power-handling and output	RF voltage at buffer amplifier output

*Adjustment Designations are keyed to Figure 1-13.

ORIGINAL

1-34

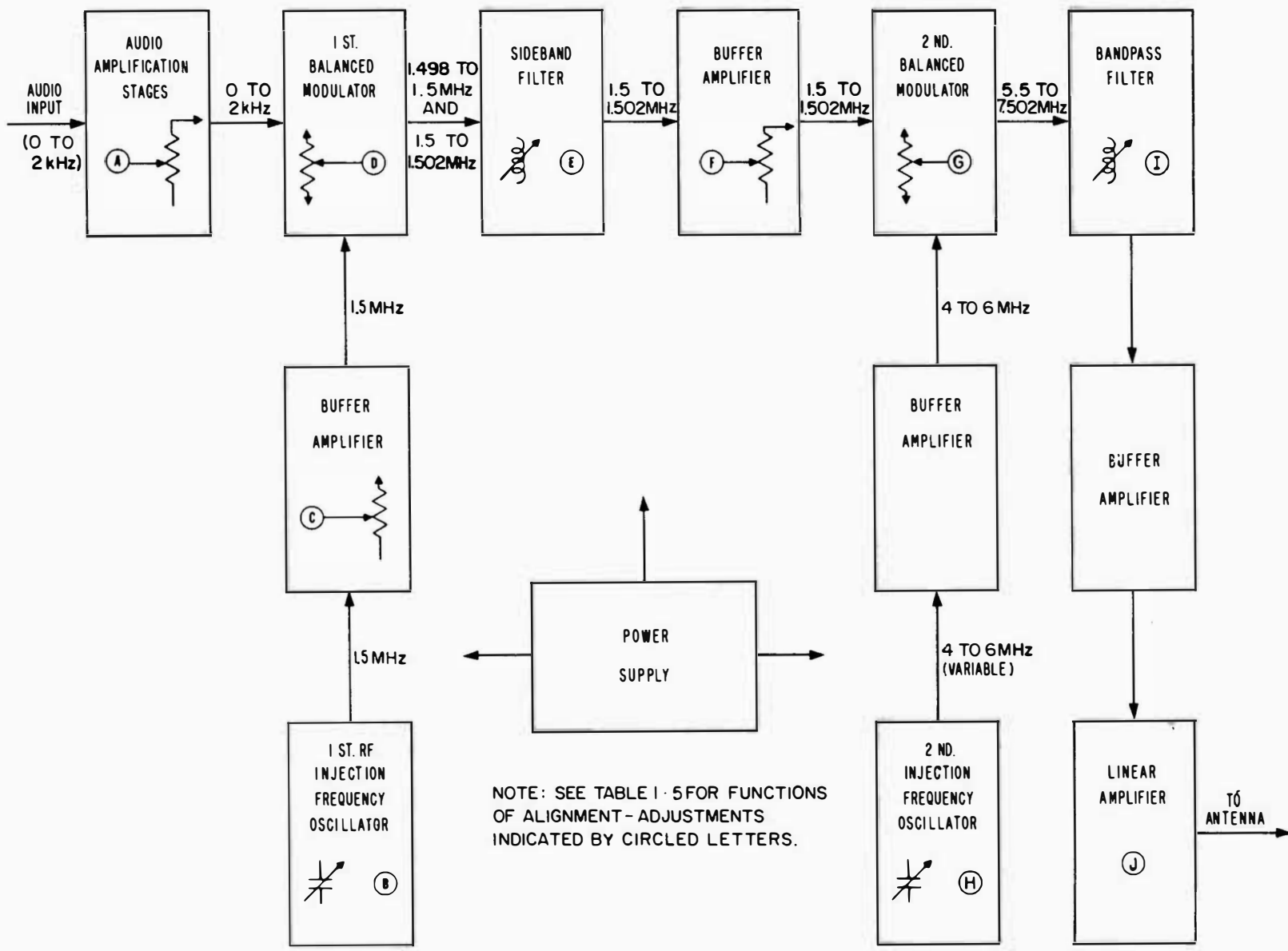

NOTE: SEE TABLE I-5 FOR FUNCTIONS OF ALIGNMENT-ADJUSTMENTS INDICATED BY CIRCLED LETTERS.

Figure 1-13. Single-Sideband Transmitter Block Diagram.

COMMUNICATIONS

NAVSEA 0967-LP-000-0010

GENERAL

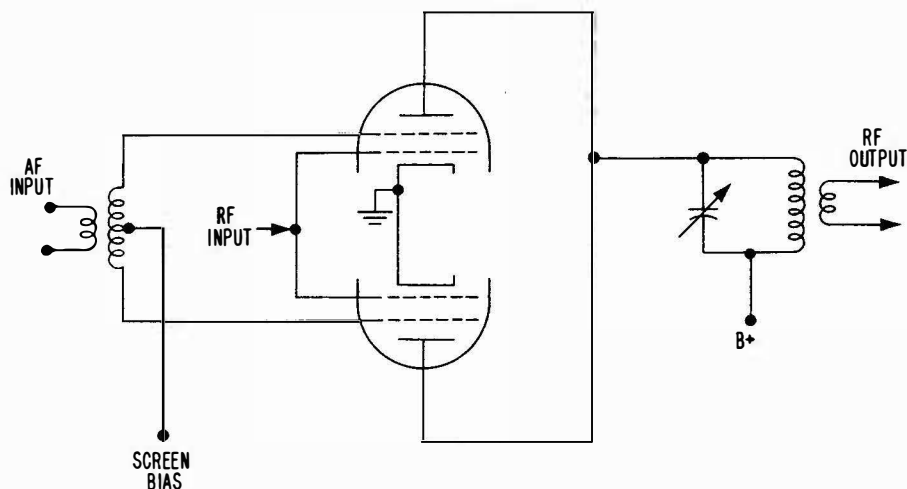

Figure 1-14. Balanced Modulator Circuitry

The procedures and indications for the adjustments of any specific SSB transmitter are given in the technical manual.

No adjustments should be made until the equipment has been installed and energized for a sufficient period (up to 6 hours for cold equipments) to reach its normal operating temperature. Frequency stability is improved by keeping the equipment heater power on at all times. This will also lengthen tube life and minimize equipment failure.

(3) Single-Sideband Troubleshooting Procedure

Troubleshooting of SSB transmitters, as of other equipments, should be preceded by determining the nature and extent of the malfunction. Troubleshooting methods are similar to those for conventional A3 equipment (signal tracing, voltage measurements, etc.), but require more accurate adjustments and therefore more accurately calibrated test equipment.

The indications given in each step following identify the circumstances under which it is to be used. The first two are for inoperative transmitters, the third is a quick, 2-signal test for directing further troubleshooting, and the rest are for locating the stage and component in which any type of malfunction originates. All step after step c require the use of an audio generator. These steps can be used without change in cases of no RF output, with a signal tracer (such as Test Set AN/USM-3) or a suitable coupled receiver in cases of distortion, and with a VTVM or oscilloscope of suitable characteristics in cases of low output amplitude. Intermittent conditions are troubleshot by gently tapping transmitter components while monitoring the modulated output. Use the

appropriate steps and test transmitter operation, either overall or at the point under study, following any change made in it. Adjustments required are identified by the letter under which listed in the table of SSB adjustments, Subsection 1-6, Single-Sideband Adjustments.

Step	Indication	Action
a.	SSB transmitter completely inoperative; no panel lights or indications	Inspect fuses and replace any that are blown. Inspect power connections and verify that power is applied to the transmitter. If malfunction is not identified by this, follow appropriate procedures of Subsection 1-7, Power Supplies.
b.	SSB transmitter inoperative; power present but no output	Verify that all control settings are compatible with the preliminary or calibrated settings. Inspect panel meters to determine if proper voltages are present; if not, follow the appropriate steps of Subsection 1-7, Power Supplies.

Step	Indication	Action	Step	Indication	Action
NOTE					
		The following steps require either an audio tone or an inserted carrier; a correctly functioning SSB transmitter otherwise has no significant RF output unless such inputs are provided. Use carrier insertion or FSK mark or space test signal if transmitter is so equipped. Otherwise, insert an audio oscillator signal, 400-1000 Hz at -10 dB (0.6V) into the microphone input. Use a receiver or frequency selective voltmeter tunable to each intermediate frequency and injection frequency to sample the signal at desired points in the transmitter.			being correctly adjusted. If bandpass filter is a tunable IF amplifier, make sure it is adjusted to track proper output of second mixer.
c.	Transmitter has no RF output.	Set up the audio generator in place of the microphone input, energize the equipment, and use the receiver, a wavemeter, or a frequency meter to test for the presence of the correct signal at the following points:	e.	IF signal present at sideband filter output but no RF signal at bandpass filter input.	Determine if the RF signal is present at the output of the second modulator. If so, trace the signal through the RF circuitry between the second modulator and the band-pass filter to locate the component responsible for the signal loss. Tube testing, voltage and resistance measurements, and tests of component condition can be used to locate defective components.
	RF signal not at output of bandpass filter	Start at Step d.		RF signal not present at second balanced modulator output.	Test for the presence of the second injection frequency and the IF inputs to the modulator, using receiver, wavemeter, or oscilloscope.
	RF signal not at input of bandpass filter	Start at Step e.		No second balanced modulator output, but both inputs present.	Troubleshoot the second balanced modulator stage by testing the tubes and measuring socket voltage and resistance. Replace any defective components found and perform Adjustment G for second modulator balance.
	IF signal not at output of sideband filter	Start at Step f.		Second injection signal	Troubleshoot the second injection frequency oscillator circuitry, using the techniques of Subsection 1-6, RF Oscillator Or Frequency Source Malfunctions. Perform Adjustment H.
	IF signal not at input of sideband filter	Start at Step g.		IF input to second balanced modulator is absent.	Trace for this signal in the circuitry between the sideband filter and the second balanced modulator. When the signal is found, determine the cause for its loss by testing tubes, making tube socket voltage and resistance measurements, and testing component/condition. Replace any components found to be
		If the RF signal is obtained at each of these points but not at the transmitter output, follow the appropriate steps given in Subsection 1-6, Transmitters. Make alignment adjustment if required. Otherwise, start with the step given for the lowest test point at which the signal cannot be found—at Step e, for example, if the RF signal is not present at the bandpass filter input, but the IF signal is present at the sideband filter output.			
d.	RF signal present at input but not output of bandpass filter.	Adjust band-pass filter (Adjustment I), following directions given in technical manual. Replace filter if it is apparently incapable of			

Step	Indication	Action	Step	Indication	Action
		defective. Perform Adjustment F, if needed, and verify that the RF signal is present at the second balanced modulator output and at the transmitter output.			necessary, to determine where audio signal is lost. If no modulation circuitry output is found, use the Modulator Trouble-Shooting procedure, Subsection 1-6, to correct the malfunction. Make Adjustment A if necessary.
f.	IF signal present at sideband filter input but not at output.	Verify that input frequencies are correct (perform Adjustment B if necessary) and make Adjustment E of sideband filter, following directions given in transmitter technical manual. Replace sideband filter if it is apparently incapable of being adjusted correctly.		No first injection frequency input to first balanced modulator found previously.	Follow appropriate steps of Subsection 1-6, RF Oscillator or Frequency Source Malfunctions, if signal-tracing shows that the oscillator is not operating correctly. Make Adjustment B of oscillator frequency and Adjustment C of injection signal amplitude if required.
g.	IF input to sideband filter is absent.	Determine if the IF signal is present at the first balanced modulator output; if so, trace the signal from that point toward the sideband filter input. When the point of signal loss is located, use tube testing, voltage and resistance measurements, and component condition-testing techniques to identify the cause of the malfunction. Replace any defective components found and verify that the filter input is now present.	h.	Carrier present in RF output.	Make Adjustment D (modulator balance). If the carrier is still present, check and, if necessary, readjust using Adjustment B (first injection frequency) and E (sideband rejection filter band-pass).
	No IF signal at balanced modulator output.	Measure the amplitude of AF and first injection frequency inputs to first balanced modulator. If both are present at the correct level, troubleshoot the balanced modulator by means of tube testing, tube socket measurements, and tests of component condition. Replace defective components, make modulator balance, Adjustment D, and verify that the correct output is now present.			
	No AF input to first balanced modulator found previously.	Check all audio cables, connectors, terminals and switches for continuity; use signal-tracing techniques, if			

e. MODULATORS

The simplest transmission conveying information is a CW transmission — an A1 emission. The same equipment can be used for phone transmission if circuitry for amplitude-modulation of the A1 emission is added. This signal resulting is an A3 emission.

(1) Methods of Amplitude Modulation

High level modulation, commonly used in conventional amplitude modulation, applies the modulating wave to the transmitter power amplifier (PA). Because 100% modulation requires that the modulating wave power be 50% the power of the carrier, a large modulator is required to plate-modulate a high-level stage. For control grid, suppressor grid, or screen grid modulation, a smaller modulator can be used, but PA efficiency suffers. In order to achieve 100% modulation, a tetrode or pentode PA stage requires that modulation be applied to both the screen grid and the plate; a transistor PA stage requires that modulation be applied to both the PA stage and the driver (IPA) stage. Figure 1-15 shows the typical stages of a high-level modulator.

Low level modulation is accomplished in a low power stage other than the PA, usually in or near the frequency generation circuits. Obviously, less modulator power is required. Low level modulation is typically used for FM and SSB. Note that post-modulation frequency multiplication will multiply the frequencies of the modulation products as well as the carrier frequency. This is acceptable (and commonly used) in FM, provided that, after frequency multiplication,

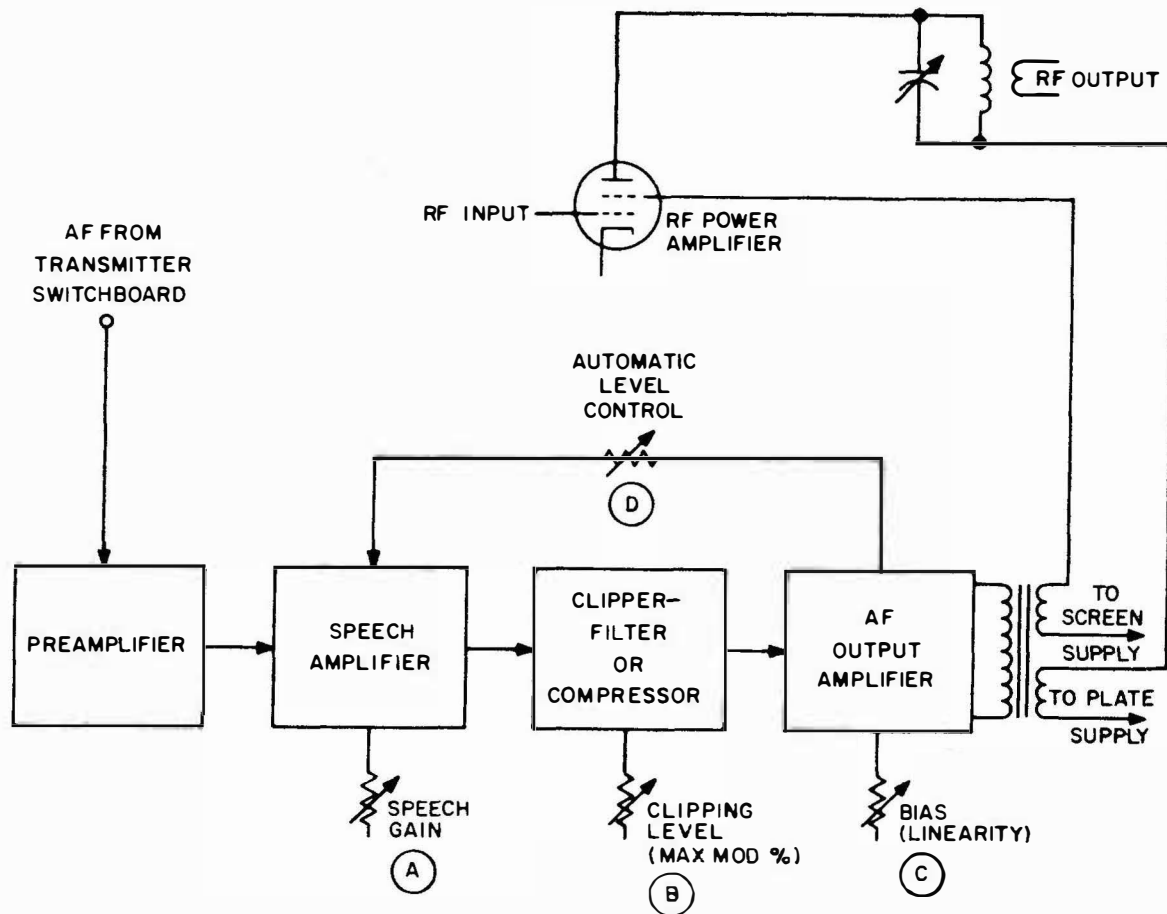

Figure 1-15. Typical Modulator Block Diagram

the necessary bandwidth limits are not exceeded. In AM transmitters, post-modulation frequency multiplication cannot be used; only unmodulated frequencies are multiplied. Therefore SSB, ISB, and other forms of amplitude modulation performed in low level stages are translated to the desired output frequency by heterodyning rather than by frequency multiplication. In addition, all post-modulation amplifiers for AM must be linear (i. e., Class B, AB, or A amplifiers) in order to avoid amplitude distortion.

(2) Monitoring Amplitude Modulation

For test and adjustment of AM transmitters, with or without carrier, the arrangement of Figure 1-16 can be used. An audio input of 300-3000 Hz, variable from 100 mV to 1 volt, is inserted into the transmitter microphone jack. When the audio generator is set for 1 volt, at least 20 dB attenuation is needed. The A-F input attenuator should preferably be a calibrated type (a spare AN/SGC-1A REC LEVEL control will serve). The R-F output voltage developed across a 50-ohm dummy load is applied directly to the scope vertical deflection plates. Vertical deflection size is controlled by a capacitive attenuator. For low power transmitters (less than 20 watts) it may be

necessary to replace the attenuator with a resonant circuit in order to develop sufficient deflection voltage.

For trapezoidal patterns, the scope horizontal deflection amplifiers are driven by the audio signal as shown. For envelope patterns a sawtooth (internal) scope sweep is used, synchronized with the modulating audio. For two-sideband tests, either use two audio generators on different frequencies in an SSB setup, or use one audio generator into separate ISB inputs.

This or any suitable method of checking modulation should be used if reports of signal distortion or "splattering" (emission beyond the normal bandwidth limits) are received.

Figure 1-17 (A and B) shows trapezoidal and envelope patterns which are useful for checking performance and making adjustments of amplitude-modulated transmitters.

Modulation Pattern a — No carrier and no modulation. If the transmitter is supposed to be emitting a carrier, an RF output malfunction is indicated. The pattern is normal for SSB when no modulating signal is present.

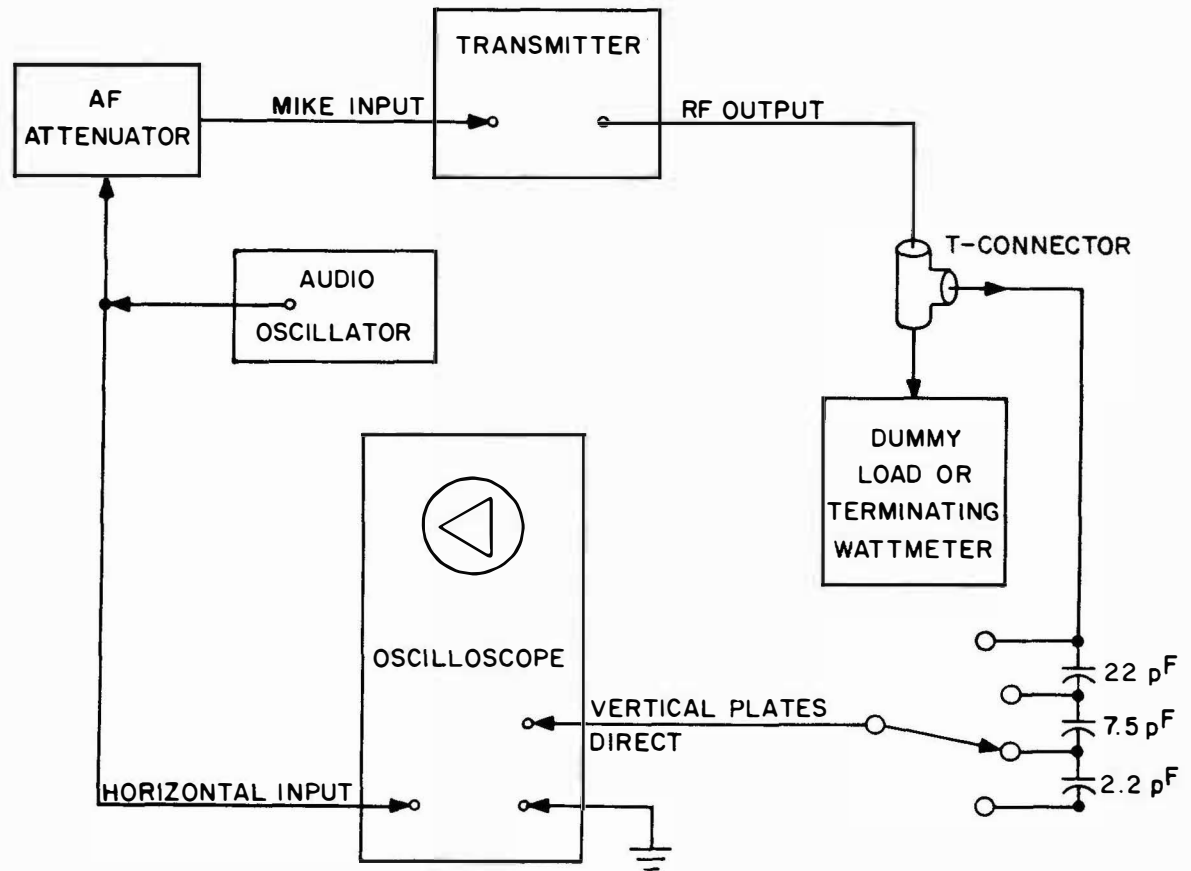

Figure 1-16. Oscilloscope Connections for Monitoring Modulation

Modulation Pattern b - Carrier with no modulation. If the transmitter is supposed to be modulated, an AF malfunction is indicated.

Modulation Pattern c - 50% modulation with full carrier. The same envelope (but not trapezoid) will be produced for SSB with 50% (-3 dB) carrier insertion, or for two sidebands when one sideband is twice the amplitude of the other.

Modulation Pattern d - 100% modulation with full carrier. The trapezoid pattern will be the same for single sideband or two sidebands at 100% modulation, with or without carrier.

Modulation Pattern e - 100% single sideband single tone modulation with no carrier. Note that the envelope pattern is the same as that of an unmodulated carrier.

Modulation Pattern f - Two equal sidebands with no carrier. Note that the cross-over at the null points form a definite "X". The presence of carrier would be indicated by peaks differing in height, alternately. The amount of carrier would be indicated by the amount of difference in height until, at full carrier, the pattern shown at d is produced.

Modulation Pattern g - Excessive modulation in the downward direction with carrier present. This indicates that excessive modulating audio is being applied, or that insufficient carrier is inserted. The trapezoid pattern will be the same for excessive single sideband and two sideband modulation.

Modulation Pattern h - Modulation in excess of upward modulation capabilities with carrier present. Note flat-topping of the peaks. Upward modulation peaks can be much greater than twice the carrier amplitude without constituting overmodulation unless flat-topping occurs. The trapezoid pattern also indicates excessive single sideband or two sideband upward modulation, which may be caused by overdrive of any stage to which the AF or RF signal is applied. A two sideband (or multiple sideband) envelope pattern would show similar flat-topping as a consequence of overdriving or underloading a linear RF amplifier.

Modulation Pattern i - AF phase shift in the speech amplifier section. Phase shift is not readily apparent in an envelope pattern (except by comparison on a dual-trace scope), so none is shown. Modulation approximately 50%.

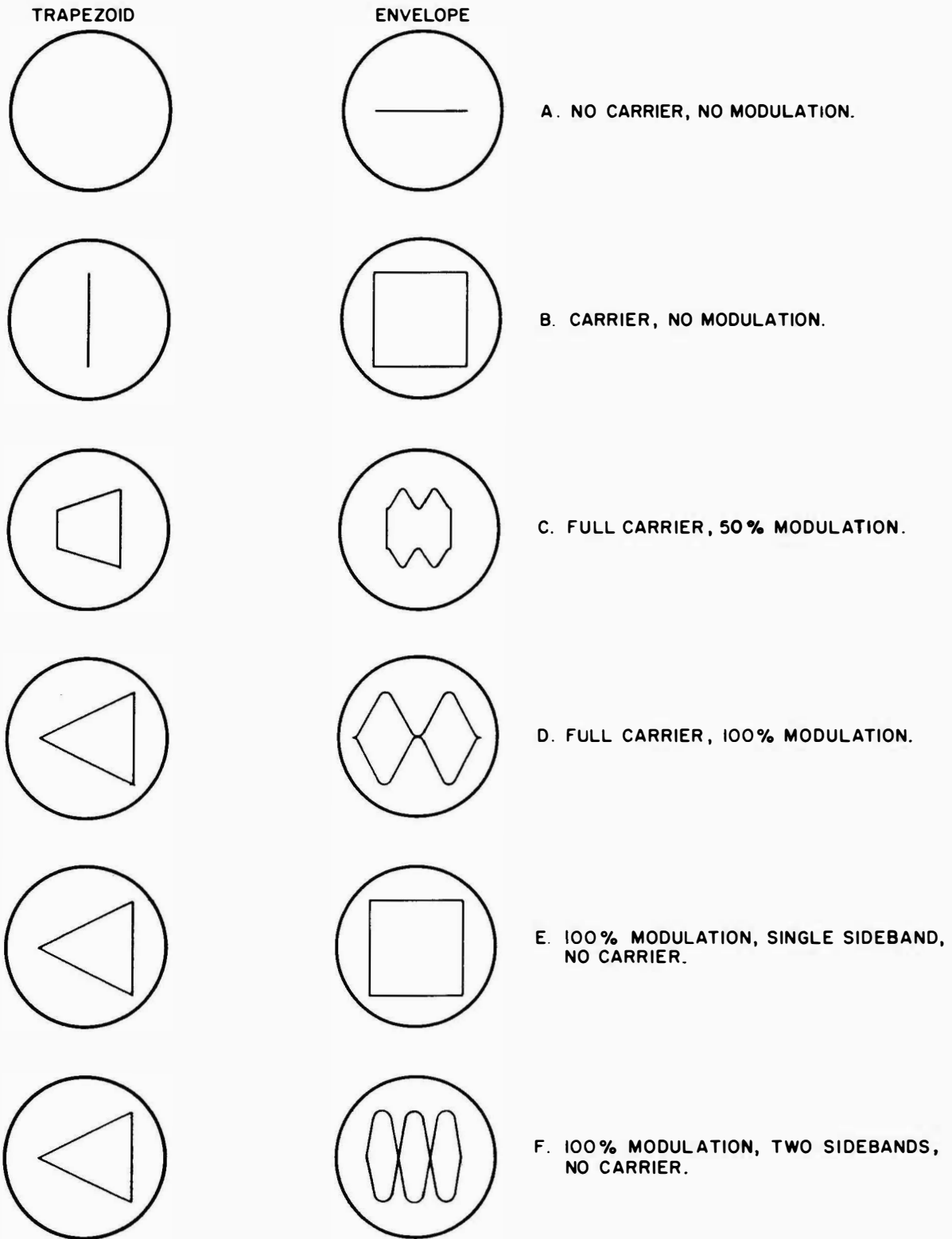
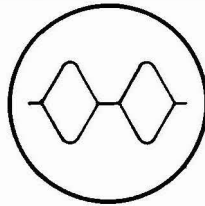
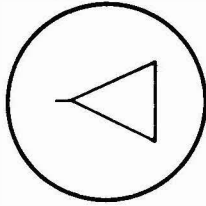

Figure 1-17A. Modulation Patterns Obtained on an Oscilloscope

TRAPEZOID

ENVELOPE



G. DOWNWARD OVERMODULATION, WITH CARRIER.

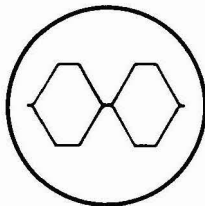
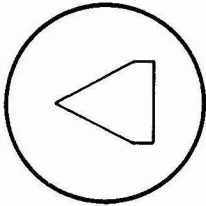

H. UPWARD OVERMODULATION, FULL CARRIER.

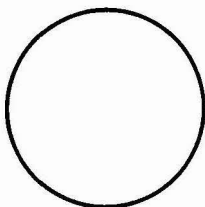
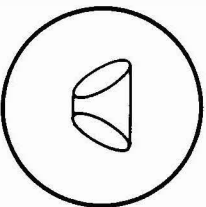

I. PHASE SHIFT IN AUDIO SECTION.

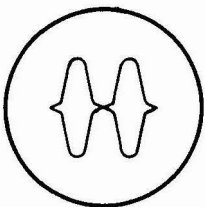
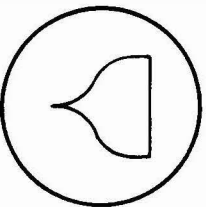

J. NON-LINEARITY, TWO SIDEBANDS, NO CARRIER.

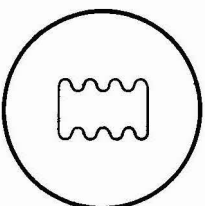
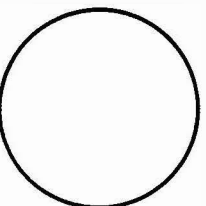

K. CARRIER LEAKAGE, SINGLE SIDEBAND.

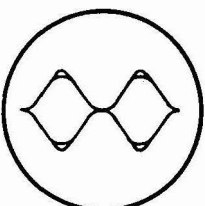
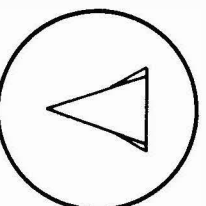

L. PARASITIC OSCILLATION.

Figure 1-17B. Modulation Patterns Obtained on an Oscilloscope

Modulation Pattern j — Non-linearity for two sidebands and no carrier. Note that the envelope does not show a sharp "X" at the crossover points (compare with f). The trapezoid pattern would be the same for any form of AM, with or without carrier. For low level modulation, the non-linearity could be in any stage which amplifies the AF signal or modulated RF signal. Improper bias or improper loading of some stage is indicated. The pattern is normal for screen grid or suppressor grid modulation.

Modulation Pattern k — Single sideband with the carrier not completely eliminated. Indicates that the SSB modulator is not balanced, or that RF is leaking around the balanced modulator. Insufficient rejection of the unwanted sideband is similar except that the ripple frequency would be twice as great. Hum modulation of SSB (or of carrier and no sideband) is also similar except that the ripple would be at the hum frequency.

Modulation Pattern l — Parasitic oscillation on modulation peaks. The peaks appear to be "snow-capped" with a fine-grain pattern. Indicates inadequate neutralization or shielding.

(3) Modulator Adjustments

Modulator circuits should be set according to the standard audio distribution levels of the ship or station concerned (see Audio Level Control at RPU's in Subsection 1-9). Thereafter it is seldom necessary to make further operational adjustments unless the audio levels are changed, or the power input or loading of the modulated stage is changed. The four principal adjustments are shown in Figure 1-15. Not all transmitters have all four.

The test arrangement of Figure 1-16 will be of great benefit in making the proper adjustments. Because the controls are interrelated, the technical manual for the particular transmitter should be used for guidance. In general, the adjustments function as follows:

Speech gain, Adjustment A is set for sufficient gain to permit the weakest voice or tone signal, arriving over the longest line, to amply modulate the transmitter.

To prevent strong audio peaks from overmodulating the transmitter, clipping level, Adjustment B, (sometimes called maximum modulation percent) is set to clip any peak audio that might exceed the highest allowable level. When speech gain is set so that moderate clipping of speech is present, the ratio of average-to-peak modulation is increased. Because the clipping action introduces distortion, an audio filter is also provided. Usually the clipper-filter can be switched in or out at will. Some modulators use a logarithmic speech compressor rather than a clipper-filter because fewer distortion products are generated. The speech gain control and the clipper-filter operate together to provide a high average power in the sidebands, without generating extra bandwidth through overmodulation or distortion. Clipping is beneficial on voice, undesirable on tone modulation.

Many transmitters have a bias or linearity adjustment, Adjustment C. For high level modulation, it is in the "modulator" or AF power amplifier. When modulation takes place in a low-level stage, the bias adjustment is in the RF power amplifier. It is adjusted to place the amplifier in the most linear portion of its transfer curve. Compare oscilloscope modulation patterns f and j of Figure 1-17.

Automatic level control (ALC), Adjustment D, sometimes called automatic gain control (AGC) or automatic volume control (AVC), operates to keep average modulation nearly constant even with audio inputs which vary widely in amplitude or numbers of tones. It allows the speech amplifier to operate near full gain for weak signals, but reduces the gain when stronger signals are present. It therefore tends to prevent overmodulation, except that it functions as an averaging device rather than a peak limiter like the clipper-filter. Its action provides the proper input level to the clipper stage for efficient clipping. If a low-level stage is modulated, the ALC circuit takes its input from the RF power amplifier rather than the AF power amplifier.

When modulator adjustments are properly made, all audio inputs from a mumble to a shout will produce ample modulation without overmodulation. (EIB 612)

(4) Modulator Troubleshooting

Any type of modulator is essentially an audio amplifier which is coupled to a transmitter; modulator troubleshooting methods therefore resemble those for conventional audio amplifiers. Use the appropriate steps to identify and correct any modulator malfunctions.

f. LINEAR RF AMPLIFIERS

The introduction of single sideband to the fleet has brought about a new generation of transmitter equipments. Examples include AN/WRT-2, AN/WRC-1, AN/URC-23, AN/URC-32 and AN/URC-35. Because modulation of these transmitters is performed in low-level stages, power amplification must use linear amplifiers instead of class "C" amplifiers common to older equipments. It is the linear amplifier that places a special requirement on the "care and feeding" of SSB transmitters.

Linear power amplifiers are limited by their peak power handling capability. Unfortunately, the panel meters read AVERAGE power rather than PEAK power. The average undistorted power of a linear amplifier is affected by the type of signal that it is amplifying and by the loading of the amplifier. In technical terms, it is limited by the peak-to-average power ratio of the modulation envelope, and by load mismatch, which, for the PA, is represented in part by the voltage standing wave ratio (VSWR) of the antenna feedline. SSB transmitters therefore employ antenna tuners with a VSWR indicator to make sure the antenna feedline presents a nonreactive load to the PA. This simplifies matching the PA plate tank to the antenna. Old Navy transmitters used class "C" amplifiers which were limited in power output by how well an operator could "tweak" them up before the PA plate blushed red. If you try "tweaking" an SSB transmitter to get maximum indicated power output, you get some disconcerting and sneaky results.

The following should be considered to be the MAXIMUM power capabilities of the AN/WRT-2 transmitter:

Peak Envelope Power	1000 Watts
CW (A1)	500 Watts
FSK (F1)	400 Watts
SSB Voice (A3J)	500 Watts
AM Phone (A3)	300 Watts
8-Channel Multiplex (A7J)	175 Watts
16-Channel Multiplex (A7J)	130 Watts

The maximum power outputs for AN/URC-32 transmitters is somewhere around one-half of those listed for the AN/WRT-2. The tuning procedures in the technical manual should be followed and the above specified limits used as a check. However, because of the antenna loading effects and aging of transmitter PA tubes, power output using correct tuning procedures may be substantially less than that given. An attempt to drive the linear amplifiers to a higher power output is likely to result in overmodulation. The effect would appear as shown in modulation pattern h of Figure 1-17.

Peak envelope power (PEP) indicates a maximum capability of the transmitter that should not be exceeded during any portion of the modulation envelope if distortion is to be avoided. In order to keep the transmitter within its PEAK ratings, it is essential that the AVERAGE power as indicated on the RF output meter be adjusted for the type of emission that is being transmitted.

For example, on SSB with two equal tones in the upper sideband and with suppressed carrier, the DRIVER or EXCITER should be adjusted for an RF output meter reading of 500 watts average power to obtain the rated PEP. With four equal tones under the same conditions, the RF output meter should indicate 250 watts average power for a PEP of 1000 watts. In ISB operation, with two tones in the upper sideband and two tones in the lower sideband (four tones in all), the RF output meter should also read 250 watts for rated PEP. Thus, the combined modulation in both sidebands determines the ratio of PEP to average power.

Whenever carrier is inserted, it usurps a portion of available power and thereby reduces the power that can be devoted to the sidebands.

Let's observe what happens when we overdrive (overmodulate) a transmitter modulated with a multiplex teletype signal. When an SSB transmitter is modulated to the peak of its power capability, the signal is at least 35 dB above the noise level that the transmitter is also generating. Any further increase in indicated power output will result in overmodulation distortion of the signal and a rapid increase of noise power. In other words, the indicated increase of average power is signal degradation rather than improvement.

With severe overmodulation, the indicated increase of average output means that the transmitter is no longer putting out a narrow signal of 3 kHz with some small additional noise within 10 kHz of the assigned frequency. Instead, the transmitter is emitting significant noise hundreds of kilohertz either side of the assigned frequency. The transmitter is also emitting very large signals at its harmonics and at the frequency of its "unwanted" sideband. If several transmitters are keyed simultaneously, intermodulation products show up as large signals throughout the spectrum. Interference levels become so great that only strong signals can be copied. Further details appear in EMI Reduction EIMB (NAVSHIPS 0967-000-0150) Section 7.

The same considerations apply to voice circuits as to multiplex teletype circuits because the transmitter sees the same peak-to-average power ratios. During a fleet operation previously mentioned, it was the rule and not the exception that voice transmissions were distorted to various degrees by overmodulation. This was more so the case when SSB transmitters

were used in the AM (A3) mode than it was when they were used in the SSB (A3J) mode. 30% of the stations on one A3 net were overmodulated to the point where voice quality was seriously degraded. Nearly all the transmitters on this net were identified as SSB type by the absence of one sideband on the spectrum analyzer display.

What effect does overmodulation have on the performance of voice circuits? You can bet that, when you hear a transmitted voice that sounds as if the operator were speaking with a mouthful of mush, it is because of overmodulation and not because the operator has a mouthful of mush. Overmodulation can be due to many causes; the main one for SSB transmitters is an attempt to increase the indicated RF output, thereby driving a linear amplifier beyond its limits of linearity. Most transmitters can compensate for differences in audio inputs to the transmitter caused by differences in radio handsets or speech levels used by operators (see Modulator Adjustments). It is up to the transmitter operator, however, to see that the tuning, loading, speech gain, and drive (or excitation) adjustments are set to keep the linear amplifiers operating in a linear manner.

The most reliable way to make the initial adjustments for amplifier linearity is to use an oscilloscope in a test setup such as that shown in Figure 1-16. A spectrum analyzer is also useful for checking distortion products. Once the operator is familiar with the meter readings at the point where distortion begins, the meters can be used for monitoring - with only an occasional verification by the oscilloscope method. If desired, it is a simple matter to arrange the spectrum analyzer or test setup as a permanent "on the line" monitor. (EIB 623, 734)

(1) Peak Envelope Power

When an SSB transmitter is modulated with tone multiplex equipment such as the AN/UCC-1, care must be exercised to ensure that the transmitter peak envelope power (PEP) rating is not exceeded. Exceeding PEP ratings in multitone operation will cause intermodulation distortion of the tones and result in deterioration of the radiated signal.

PEP is defined as the rms power developed at the crest of the modulation envelope when the transmitter is modulated with multiple audio frequencies. If an SSB transmitter is modulated with two audio tones of equal amplitude, and an oscilloscope is connected as shown in Figure 1-16, a two-tone test pattern may be observed. The PEP of a transmitter may be computed by measuring the rms voltage (0.707 of peak), squaring this value, and dividing it by the load resistance (normally 50 ohms). With two-tone modulation, such as that shown at modulation pattern f of Figure 1-17, the average power output will be equal to one-half of the PEP.

With multitone operation, the average power output will be much less than the PEP. A transmitter must divide its power capabilities among the tones modulating it. To calculate the average power of the transmitter or the average power per tone for n number of tones input, the following formulas may be used:

$$\text{Avg Pwr} = \frac{\text{PEP}}{n} \quad \text{Pwr per Tone} = \frac{\text{PEP}}{n^2}$$

Refer to Figure 1-18. Assume that a transmitter is modulated with two tones of equal amplitude, f_1 and f_2 , and its output is terminated into a resistive load of 50 ohms. The voltage in each output frequency is measured and found to be 112 volts rms. Squaring the voltage in each output frequency and dividing that by 50 reveals the power in each output frequency to be 250 watts. The sum of these two is 500 watts, which is the average power output of the transmitter. When the two output frequencies fall in phase with each other as shown in vector diagram b, the crest of the modulation envelope is reached and the voltages add up to 224 volts. Square 224 and divide by 50 to obtain the PEP of 1 kW. From this illustration, we see that the average power for two-tone modulation is one-half the PEP.

A transmitter modulated with 16 tones would have a theoretical average power output of only 64 watts with a PEP of 1 kW. In practice however, it has

been found that this theoretical average limit can be exceeded by approximately twice this value without introducing appreciable distortion.

Overdriving a linear amplifier generates intermodulation distortion products which result from harmonics of the desired frequencies mixing with fundamentals and other harmonics. The power usurped by these undesirable products is taken from that available to desired intelligence frequencies and decreases the effective radiated intelligence.

Tone channels applied to the transmitter should contain intelligence; idle tone channels must be turned off. This practice will ensure that the transmitter power will be distributed to each intelligence-bearing frequency. Transmitter power output should never exceed the level required to maintain communications. Excessive power levels will damage components of the transmitter and antenna tuner. (EIB 727)

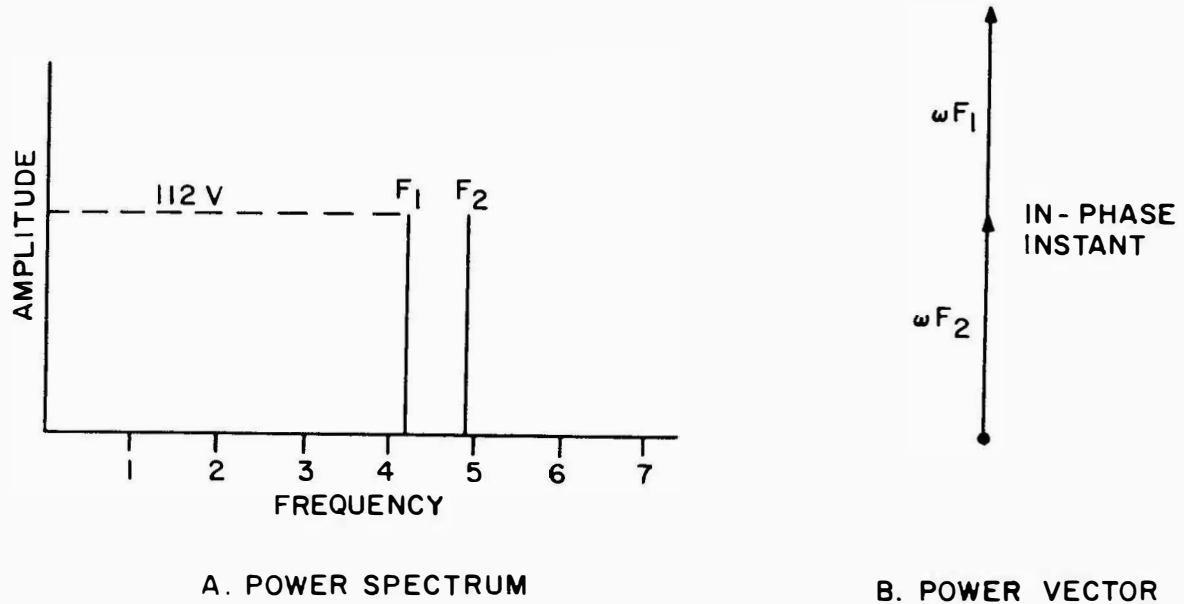

Figure 1-18. Calculating Average Power and Peak Envelope Power for Two-Tone Modulation

1-7 POWER SUPPLIES

Power supplies which are part of Transmitting Equipment, Subsection 1-6, or Receivers, 1-8, can be placed in a category with one of the types described in this section. Since troubleshooting procedures are the same for part of the self-contained equipment as for the unit-type power supplies, regardless of voltage and current requirements, the description is not repeated in Subsections 1-6 and 1-8.

Power supplies commonly used in electronic equipment are of the following types:

1. Unregulated supplies, usually providing filtered but unregulated low B-plus (under 300VDC) or high B-plus (over 300VDC), in addition to AC

heater power for vacuum tubes and in some cases relay-operating power.

2. Regulated power supplies, consisting of an unregulated supply and associated circuitry to regulate the B-plus output.

3. Motor-generator sets to supply the above voltages. Troubleshooting malfunctioning power supplies should be preceded by a preliminary check-out procedure covering the simple, easily overlooked causes of trouble. This preliminary troubleshooting procedure is followed by the procedures for the basic unregulated power supply and the regulating circuitry. Motor-generator sets, on the other hand, require continual routine maintenance of a mechanical rather than electrical nature, but little troubleshooting. Both maintenance and troubleshooting procedures for motor

generators are given in Paragraph 6-2 of General Maintenance, NAVSHIPS 0967-000-0160.

a. PRELIMINARY POWER SUPPLY TROUBLESHOOTING PROCEDURE

The quick checkout procedure given in Table 1-6 can be performed without removing the equipment from its cabinet or console. Some steps result in correction of the malfunction, while others determine on what following step to proceed.

TABLE 1-6. POWER SUPPLY QUICK CHECKOUT TROUBLESHOOTING PROCEDURE

Step	Condition	Check	If	Action
a.	No power and no panel lights	Line cord	Not plugged in	Plug in
		Fuse	Defective	Replace
			Good	Start with Step b.
			Blown	Check dial settings and replace fuse
		Blows again	Start with step a in Table 1-7.	
		Switch and dial settings	Incorrect	Set correctly
			Cables	Unplugged
b.	Input power present, but some voltage indications at supplied equipment not normal		Plugged in	Start with Step b in Table 1-7.

c. REGULATED POWER SUPPLY TROUBLESHOOTING PROCEDURE

1. If any symptoms of the regulated power supply resemble those for the unregulated type of supply, troubleshoot them by using the appropriate steps given for the unregulated supplies. If necessary, disconnect the regulating circuitry for troubleshooting and repair in these steps.

2. Verify that the unregulated output are of the correct voltage. The a-c voltages (5.0VAC and 6.3VAC) are usually unregulated and can be measured at the unit's output. The unregulated d. c. can be measured at the input to the series-pass tubes or at the regulator output, with the shunt-regulator tubes removed.

3. Determine the effectiveness of regulation circuitry by adding a resistive load that is ten times the resistance of the real load. Use resistors of power capabilities no less than that calculated from the resistance and the voltage. Connect this load in parallel with the normal B-plus load and insert a switch in the normal load. Meter the output voltage while switching the normal load on and off. The regulating circuitry is defective if the voltage drop under full load exceeds the power supply specifications. If this is the case, perform step d.

4. If the regulation is defective, use Tube Tester TV-3A/U or equivalent to determine the condition of all tubes in the regulating circuitry. Be sure to determine the condition of any voltage regulating tubes included. Return each acceptable tube to its original socket and replace defective tubes.

5. Make any adjustments given in the technical manual for regulation of the output voltage. Follow the directions given in the technical manual to

b. POWER SUPPLY TROUBLESHOOTING PROCEDURE

Perform the appropriate steps listed in Table 1-7 to troubleshooting unregulated supplies or the unregulated portion of regulated supplies.

set up the conditions specified for making these adjustments.

6. Make tube socket voltage and resistance measurements in the regulator circuitry, following the directions given in the technical manual for setting up the required load conditions. Replace any defective components that could cause incorrect values.

7. If acceptable regulation with load connected cannot be obtained due to excessive current drain, determine where in the load circuitry the excessive drain is occurring. This can be done by removing tubes in the supplied equipment one by one, noting how much the current requirement is reduced for each tube withdrawn. When the withdrawal of a particular tube reduces the current by an amount greater than the tube requirements (plate and screw), both the tube and its associated circuitry should be investigated. Typical reasons for excessive current are defective screen bypass capacitors, leaky decoupling capacitors, and defective (shorted or gassy) tubes. Correct the conditions causing the excessive load.

TABLE 1-7. UNREGULATED POWER SUPPLY TROUBLESHOOTING PROCEDURES

Stop	Condition	Check	If	Action
a.	Fuse blows repeatedly	Remove load, re-place fuse, and energize again	Operation is normal	Troubleshoot supplied equipment (load) for: <ol style="list-style-type: none"> 1. Tube shorts 2. Wiring shorts 3. Overheated components
			Fuse blows again	Check power supply: <ol style="list-style-type: none"> 1. Tubes 2. Electrolytic capacitors for leakage 3. Other capacitors for leakage 4. Compare power transformer winding resistances with normal values and replace transformer if defective
b.	Not all output voltages present at supplied equipment	Use voltmeter to determine where voltages are lost between transformer and supplied equipment	Open circuit is found	Make necessary repair or replacement
			One (or more) transformer outputs are missing	Use ohmmeter to verify that transformer winding is shorted or open; replace transformer
c.	Some or all output voltages are not correct	Transformer primary tap connections for various line voltages	Incorrect connection for input voltage being used	Change to correct connections
		Transformer winding voltages and resistances	Any winding is open or has shorted turns (indicated by changed resistance)	Replace transformer
d.	Incorrect DC output (following performance of Steps b and c.)	Tube condition	Tube(s) defective or has low emission	Replace Tube(s)
		Electrolytic capacitors	Defective	Replace capacitors
e.	Output voltage level varies	Intermittent conditions by metering output	Tapping component or terminal affects voltage	Inspect component or connection tapped and replace or repair if defective

1-8 RECEIVERS

This section gives generalized alignment instructions and troubleshooting procedures for superheterodyne receivers. Single-side-band techniques and receivers are included, since SSB is now widely used in naval communications, but TRF, regenerative, and superregenerative receivers are not included.

A description of the configuration of stages needed and tabulation of alignment points for superheterodyne receivers is followed by preliminary and systematic troubleshooting procedures. These are divided into "front end" (RF and IF) AGC and detector, AF and SSB receiver troubleshooting.

a. RECEIVER COMPONENTS

The simplest possible receiver consists of a resonant circuit to select the desired frequency, a detector which rectifies the RF signal to produce the AF signal across its load resistor, and an electricity-to-sound transducer, all shown in Figure 1-19. A "crystal set" is such a receiver and the now outmoded TRF (tunedradio-frequency) receiver a vacuum-tube elaboration of it. These receivers can receive A2 and A3 signals but cannot receive CW signals without modification.

The superheterodyne receiver is used in all types of radio communication because of its selectivity and adaptability to all types of reception. The

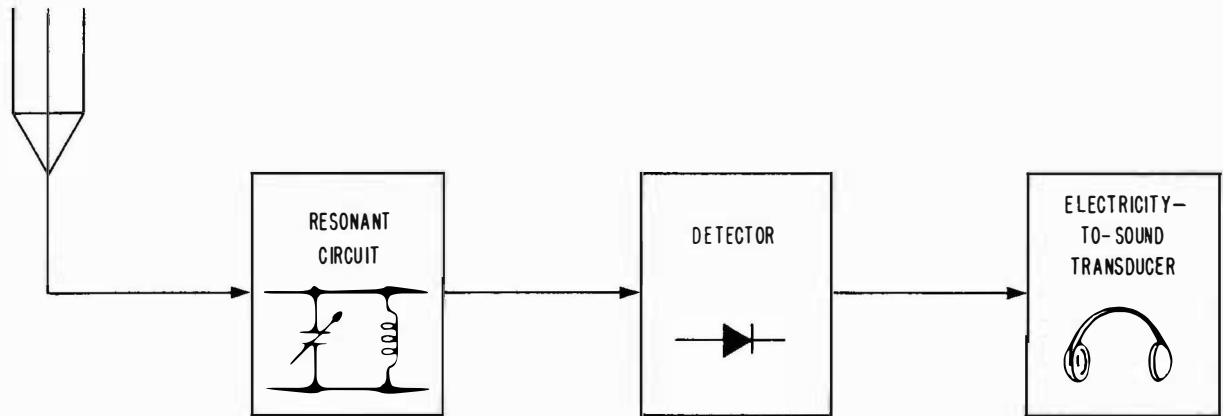

Figure 1-19. Simple Receiver, Block Diagram

simplest superheterodyne is shown in block-diagram form in Figure 1-20, but more typical ones include more stages (dotted lines in the figure) for greater sensitivity and selectivity.

The heterodyning action of the superheterodyne receiver results from "mixing" the incoming RF signal with another higher or lower RF signal, generated by the receiver's local oscillator, Figure 1-21. The local oscillator and RF tuning capacitors are ganged together and adjusted to produce the same intermediate frequency for any RF input frequency selected.

Some superheterodyne receivers are called "dual-conversion" receivers because they generate a second internal frequency to mix with the first IF signal. This forms a second intermediate frequency which is detected in the conventional manner.

Fixed intermediate frequencies are used because they have the following advantages:

1. Increased selectivity.
2. Increased and more linear sensitivity.
3. Easy filtering and feedback techniques for signal selection or rejection over the range of the IF bandwidth.

4. Bandwidth adjustment by front-panel controls is possible without adding greatly to circuit complexity.

5. CW, FSK, and SSB reception is simpler because BFO injection is at a fixed frequency.

The BFO provides a frequency which, on mixing with an signal, heterodynes it into the audio range. Because the final audio frequency is critical for SSB, FSK and MUX reception, and because it is affected by each frequency conversion step, extreme stability is required of each heterodyning oscillator (local oscillator and BFO).

Several types of detectors are used in superheterodyne receivers; the most common is a diode detector with an RF decoupling network following, which is suitable for reception of all AM signals. The product detector or balanced modulator (a form of mixer) is often used in detection of SSB signals, although the diode detector will work in this application. Ratio detectors and phase discriminators are

used for FM detection. Principles of detector operation will be found in the various electronics technicians rating manuals and in the ARRL Radio Amateur's Handbook.

Automatic gain control (AGC) circuitry or, as it is sometimes called, automatic volume control (AVC) is included in receivers to make operation easier by reducing amplification of strong RF peaks. It operates by supplying a biasing voltage to at least two early RF or IF stages, the bias increasing when strong signals are received. The biasing voltage is obtained from the AGC rectifier, which is often located in the same tube envelope as the detector diode. AGC action is disabled when a receiver panel switch is in the AGC OFF OR MANUAL GAIN CONTROL, rather than in the AGC ON position.

Single-sideband circuitry has some necessary and some desirable differences from conventional superheterodyne circuitry; the AGC rectifier samples the signal before BFO injection or detection and uses long time constants to maintain AGC action while no signal is present between periods of modulation (between words, for instance). Conventional superheterodyne communications receivers can be used for SSB reception if they have narrow-band filters, slow tuning rates, and stable oscillators. An SSB signal is received on such equipments by tuning on the sideband for maximum input indication and then setting the BFO by ear for intelligible reception.

Single-sideband reception is possible also with conventional receivers using single-sideband converters, as well as with specialized SSB receivers. SSB converters accept the receiver IF signal, select the desired sideband by further conversion and filtering, detect by mixing the sideband with an injected carrier, and supply the demodulated signal at usual audio power levels. Tuning is done first at the receiver and then at the converter, across the receiver bandpass.

Specialized single-sideband receivers now coming into use have local oscillators of sufficient accuracy and stability to permit reception by just setting the receiver to the desired frequency; tuning

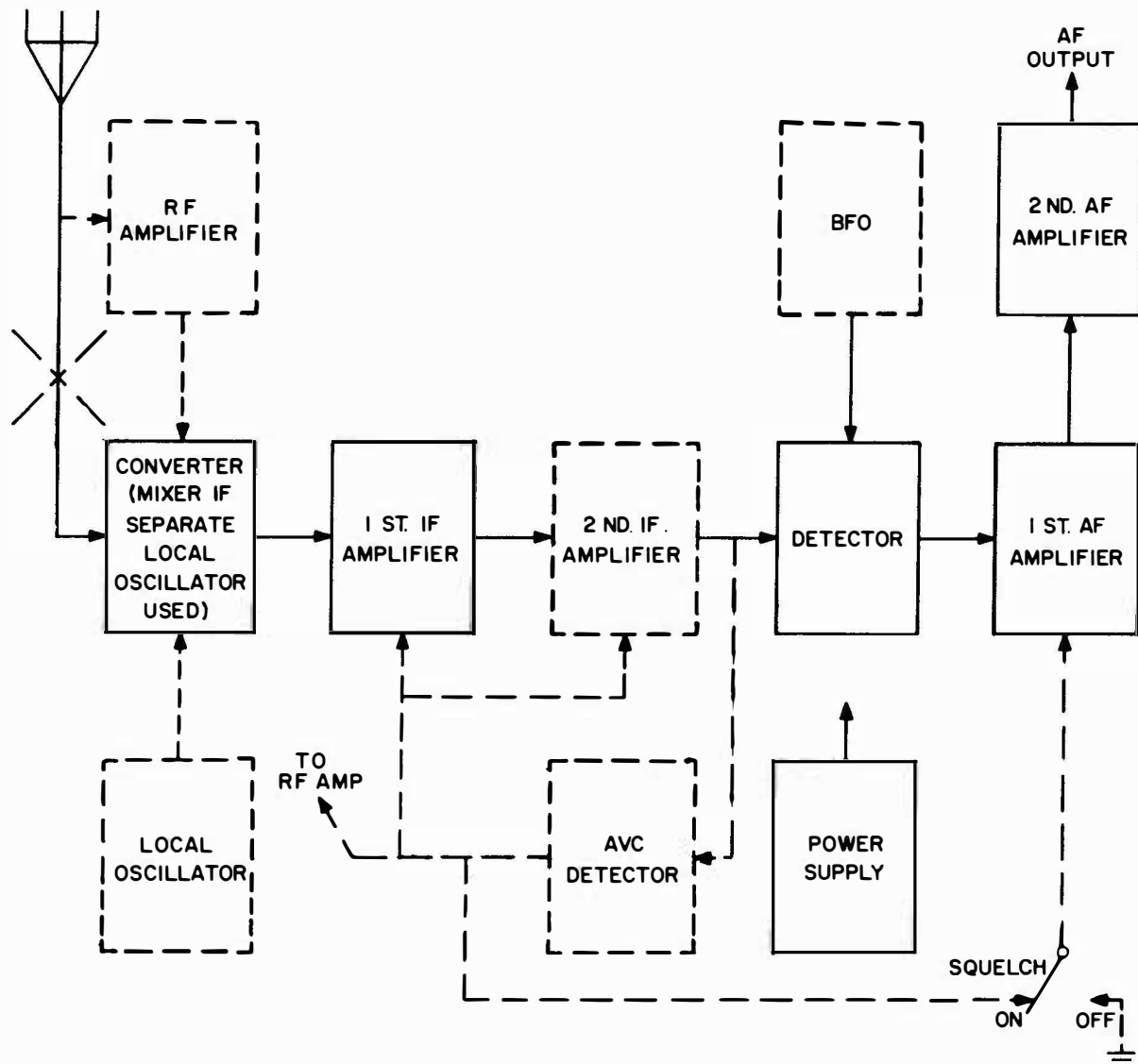

Figure 1-20. Simple Superheterodyne Receiver Block Diagram. (Stages Added for Typical Communications Receiver Shown in Dotted Lines).

by visual or aural indications is not required. The stability required is obtained in some complex equipment by deriving component frequencies from crystals and circuitry enclosed in ovens which are accurately maintained at specified temperatures. In other equipments of comparable accuracy and stability, the local oscillator frequencies are obtained from continuously variable oscillators controlled by crystal-referenced circuitry, and operating to correct for any frequency error or drift.

b. RECEIVER ALIGNMENT ADJUSTMENTS

Superheterodyne receivers can drift out of alignment after long use and consequent component aging. Some or all of the alignment steps following should

be carried out under these circumstances but should never be attempted unless it is certain that alignment is required. The need for some alignment adjustments is indicated by loss of selectivity and sensitivity, particularly if the various bands are affected to different extents. Also, alignment may be required following replacement of the local oscillator tube and if the dial indications do not conform to the actual frequency being tuned.

Do not attempt alignment to correct a malfunction which has appeared suddenly, although in the course of troubleshooting one adjustment at a time may be altered slightly and then returned to its original setting.

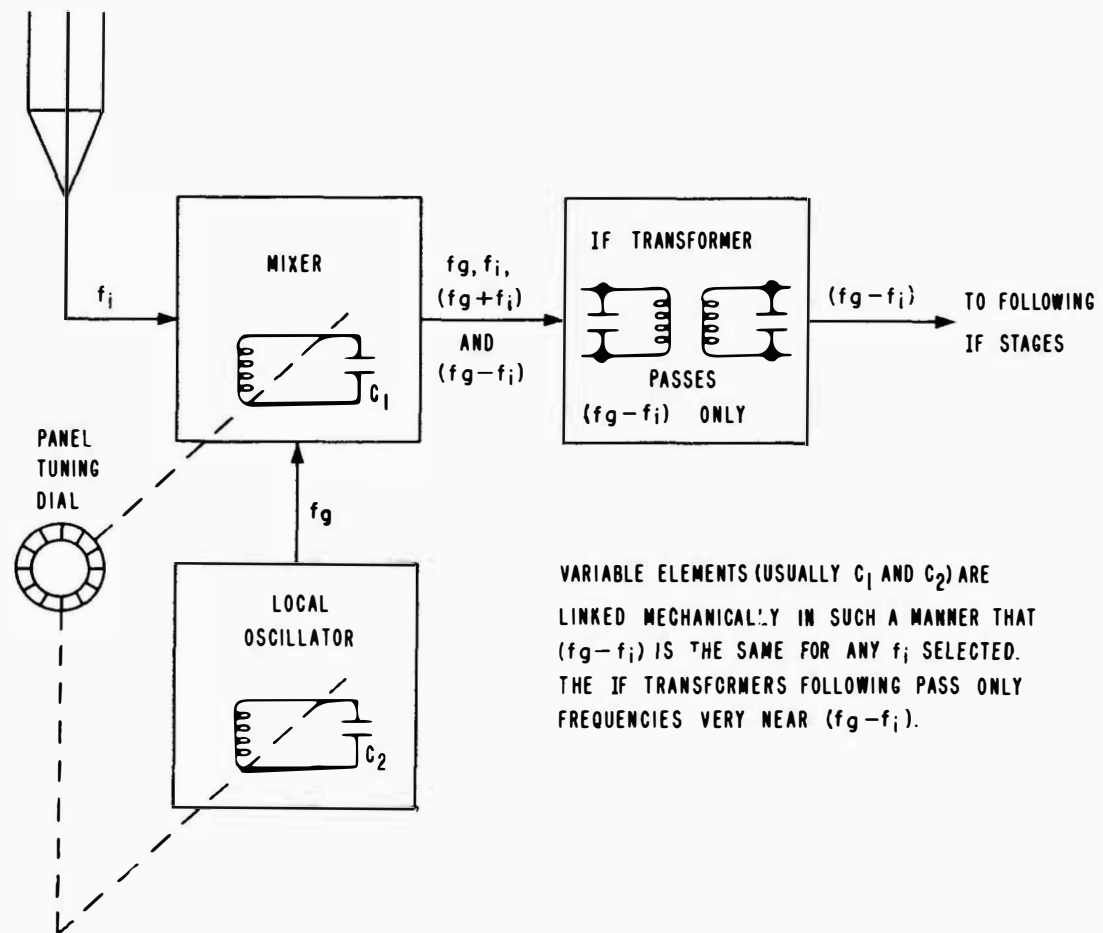

Figure 1-21. Heterodyne Action in Superheterodyne Receiver

It often happens that the stability and frequency accuracy built into a receiver by using crystal-controlled oscillators is degraded through faulty receiver alignment. This fault occurs because the AN/URM-25, AN/URM-26, LP, and similar signal generators do not have the requisite accuracy and stability. For example, the AN/URR-35 receiver requires IF alignment using a signal generator set to 18,602 kHz. It is all but impossible to read the signal generator dial that accurately - and even if it were easy to do, there is no assurance that the signal generator frequency is actually what the dial reads. Typical indication of off-frequency IF alignment is a receiver that exhibits good sensitivity to a signal generator or in continuous manual tuning, but performs badly or not at all in crystal-controlled operation.

When the usual shipboard signal generators lack sufficient accuracy and stability for accurate receiver alignment, three alternatives are available:

1. Use a frequency meter as a signal generator, or use the frequency meter to keep the signal generator on frequency.

2. Use a crystal-controlled alignment generator.

3. Use a frequency counter (instead of the signal generator dial) to put the signal generator on frequency and keep it there.

Figure 1-22 illustrates an arrangement for using a frequency counter in conjunction with a signal generator. The frequency counter requires a fairly large input signal, so the signal generator is set for maximum output (or 0.1 volt DIRECT jack used) and the external variable attenuator set to control the signal level delivered to the receiver.

In order to provide adequate IF bandwidth, some receivers use overcoupled IF transformers which produce a double-humped response curve. Tuning such an IF transformer for peak response may produce misalignment unless certain measures are taken. These measures usually consist of "swamping" the resonant circuit with a temporarily-installed load. If the receiver TM calls for alignment using a circuit-loading signal generator probe or a temporary shunt resistor, make sure it is used during alignment. (EIB 698, 735, 736)

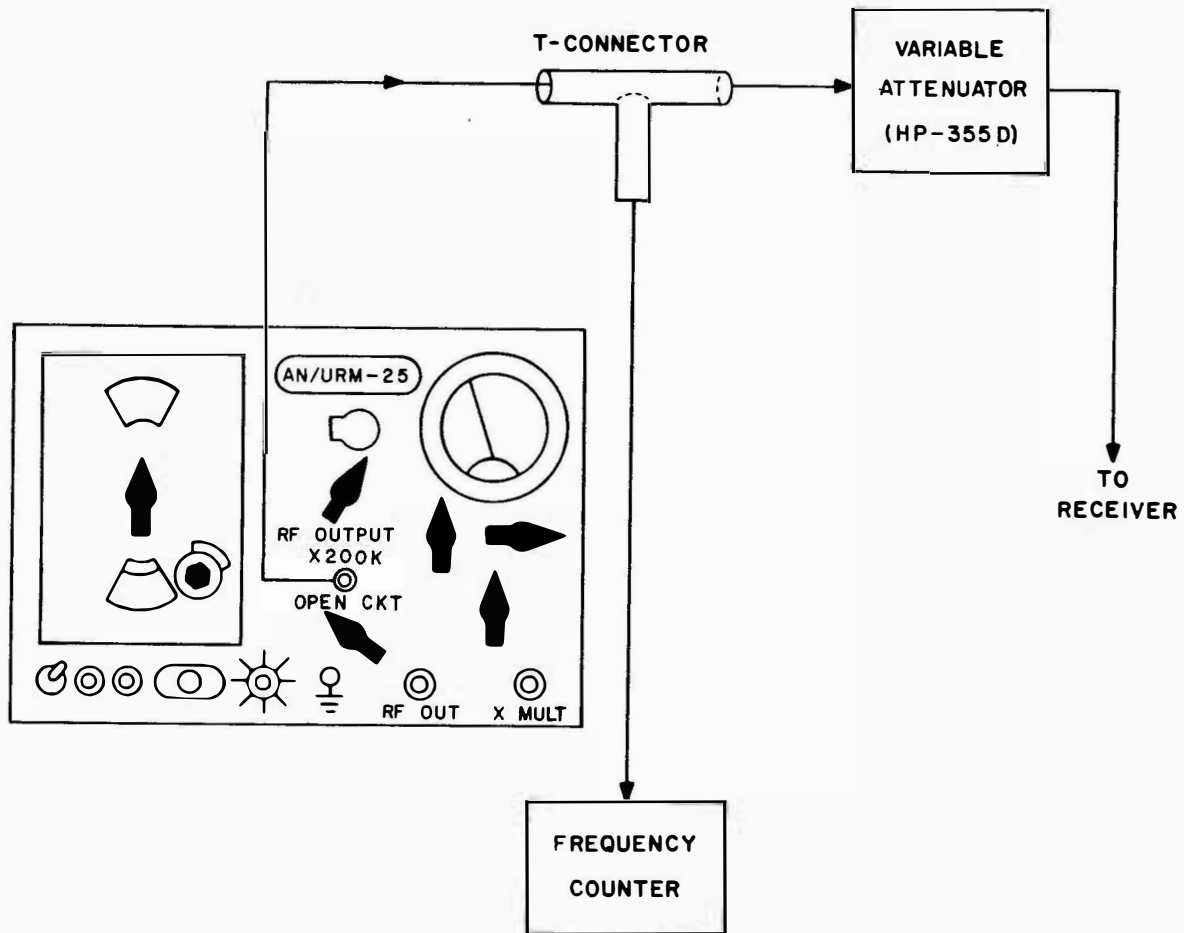

Figure 1-22. Signal Generator with 10 Hertz Accuracy

c. RECEIVER MALFUNCTION INDICATION

Receivers do not need the many indicators (meters and lamps) found on transmitters, but they are provided with some indicators that are useful in troubleshooting. Not all of these are commonly regarded as troubleshooting aids.

Analysis of the indications enables the experienced technician to identify the general area where the malfunction exists. Removal of the receiver and use of test equipment may be required then only to identify and replace the defective component.

The less experienced technician can locate the origin of the malfunction by noting the receiver's malfunction indications and using either cause-and-effect logic or the systematic trouble shooting procedures following. The Preliminary Troubleshooting Procedure is first used to determine which of the following procedures to use.

d. PRELIMINARY RECEIVER TROUBLESHOOTING PROCEDURE

These steps should be performed if the approximate location of the malfunction is not known.

The receiver need not be removed from its cabinet or console to perform these steps.

Step	Indication	Action
a.	Malfunction of any kind affects only one band or some of the bands or channels	Perform the steps given in Subsection 1-7, Single-Band or Single-Channel Malfunctions
b.	Receiver completely inoperative	Perform the steps given in Subsection 1-7, Receiver Inoperative
c.	Input meter indications low and output absent, weak, or distorted	Perform the appropriate steps given in Subsection 1-7, Front-End and IF Malfunctions

Step	Indication	Action	Step	Indication	Action
d.	Input meter indications are normal but output is impaired	Perform the appropriate steps given in Subsection 1-8, AGC and Detector Malfunctions, which may direct that the steps of Subsection 1-8, Audio Malfunctions, be performed			power is found at the primary. If not, check for presence of input power at each power switch, interlock, fuse, and connector. Correct any open-circuited connections
e.	Poor selectivity and/or sensitivity	Perform adjustments needed outlined in Subsection 1-8, Superheterodyne Receiver Alignment Adjustments and given in detail in instruction book	c.	Tubes and panel lamps light but receiver output is absent	Test all tubes on a transconductance tube tester, first testing receiver operation after replacing any obviously bad (gassy or burned out) tubes. Return to original sockets any tubes having at least half their specified transconductance and no internal shorts
f.	A3 reception normal but no A1 reception	Test all components associated with BFO by means of testing tubes continuity, and resonating inductances, as well as making tube socket voltage and resistance measurements	d.	All tubes test good but receiver output is absent	Use a VTVM to test for the presence of B-plus voltage at several plates throughout the circuit, including those at the audio output local oscillator, and an RF amplifier. If B-plus is missing at any point, search for and replace the defective component. If B-plus is absent entirely, follow the procedures in Subsection 1-7, Power Supplies

e. RECEIVER INOPERATIVE

Perform the following steps in the order given if the receiver is inoperative, omitting any inappropriate ones. Test the receiver after each change made.

WARNING

Observe all safety precautions in performing the following troubleshooting procedures.

Step	Indication	Action	Step	Indication	Action
a.	Receiver completely dead - POWER ON lamp and tubes unlit	Check fuse(s) and replace if blown. Follow procedures in Subsection 1-7, Power Supplies, if the fuse blows repeatedly. Inspect line cord and plug to make sure they are in good condition and the plug is inserted correctly. Measure line voltage at receptacle and test - operate receiver at a known good receptacle	e.	Audio output absent or at low level	With the receiver withdrawn, set the RF and AUDIO GAIN controls at their halfway settings and energize the receiver. Touch the tip of an insulated-handle screwdriver momentarily to each secondary terminal of the last IF transformer. If a loud buzz or hum is produced at the speaker or headset, the following circuitry is operating; follow the procedures given in Subsection 1-8, Front-End and IF Malfunctions. If no audio indication is obtained, apply the tip of the screwdriver to the center terminal
b.	Power input to receiver present but receiver dead - POWER ON lamp and tubes unlit	Use a VTVM or multimeter to test for input power at transformer primary. Refer to Subsection 1-7, Power Supplies, if			

Step	Indication	Action
		of the AUDIO GAIN or VOLUME control. Follow the procedure given in Subsection 1-8, AGC and Detector Malfunctions, if a loud hum or buzz results. If it does not, follow the steps given in Subsection 1-8, Audio Malfunctions.

f. SINGLE-BAND OR SINGLE-CHANNEL MALFUNCTIONS

The steps of this procedure should be performed if a malfunction of any kind affects one or possibly two bands or channels. Test the receiver after each change made.

Step	Indication	Action
a.	No input indicated and no audible output when malfunctioning band selected	Determine the condition of the bandswitch or channel switch. Adjust and clean contacts, or replace switch if necessary.
b.	No input indicated but contacts and switched components in good condition	Replace local oscillator tube and test operation on malfunctioning band. Try another new tube if this has no effect. Make adjustments for all bands if this replacement restores operation, otherwise make no adjustments and return the original tube to the socket. In this case, set the receiver to the malfunctioning band and continue troubleshooting with the procedures of Subsection 1-8, Front-End and IF Malfunctions

g. FRONT END AND IF MALFUNCTIONS

The following items of test equipment, or their equivalents, should be used in troubleshooting receiver RF and IF circuitry:

1. RF Signal Generator Set AN/URM-25 or AN/URM-26 (selection determined by frequency required)
2. Multimeter AN/USM-34
3. Test-Tool Set AN/USM-3, 3A
4. Dummy antenna, Navy Type 66017. (This can be constructed also by using the schematic diagram of Figure 1-23 following, and enclosing the components in a small chassis or box for shielding. In emergencies, a 200 pF capacitor can be used in series with the antenna lead.

Perform Step a and the appropriate steps following the order given, and test the receiver after each change until the malfunction is located or corrected.

Observe all safety precautions in performing the following troubleshooting procedures. All final alignments should be done with the equipment enclosed as nearly as possible in its operating condition. Audible or metered audio output indications can be used in making adjustments; signals should be sampled at tuned stages (RF, IF and detector input) only in signal-tracing to locate the malfunction.

Step	Indication	Action
a.	No indicated input to receiver	Test all tubes in RF, IF, and AGC stages and replace defective ones as in paragraph 1-8, Receiver Inoperative, Step c.
b.	No IF output, as tested in Subsection 1-8, Receiver Inoperative, Step e, but tubes known to be good	Replace the oscillator tube(s) with a new one and test the receiver. Try another tube(s) if this has no effect. Make alignment adjustments for all bands if the replacement restores operation, otherwise make no adjustments and return the original tube(s) to the socket
c.	No IF output, but tubes are known to be good	Set the signal generator to the frequency of all last IF transformer, modulated output, and 0.5-volt amplitude. Insert the signal across the secondary terminals of the last IF transformer. If no receiver output is found at any setting of the AUDIO GAIN control and with AGC OFF, follow the steps of Subsection 1-8, AGC and Detector Malfunctions. If output is satisfactory, insert the signal between ground and the plate of the preceding stage (last IF amplifier or second mixer) by means of a series capacitor. If no signal is present, replace the IF transformer. If signal is present go to Step e for single conversion receivers and to Step d for dual-conversion receivers
d.	Malfunction in IF circuitry (FOR DUAL CONVERSION RECEIVERS ONLY)	Set the signal generator to the first intermediate modulated output, and 0.5-volt output amplitude. Use same receiver control settings

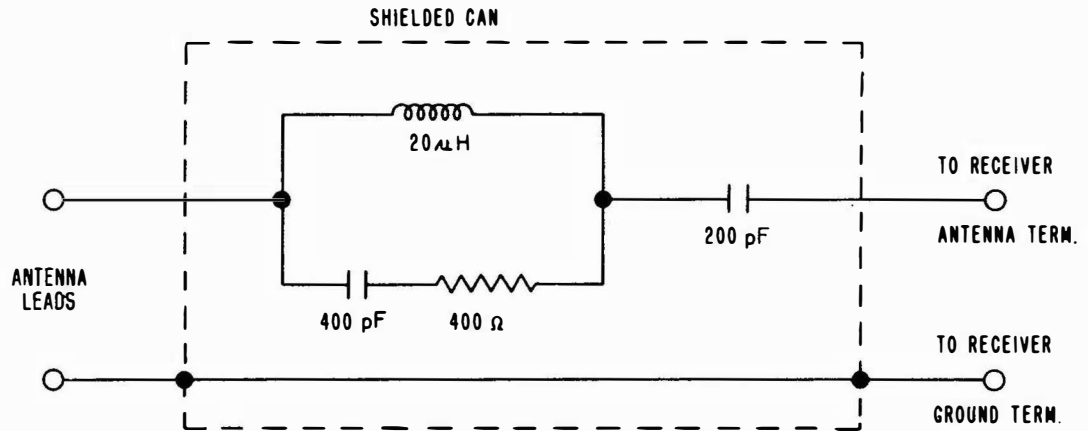

Figure 1-23. Receiver Dummy Antenna, Schematic Diagram

Step	Indication	Action	Step	Indication	Action
		as in Step c previous. Insert the signal at the second mixer signal grid; if an audio output does not result, the malfunction is in the second mixer or second oscillator circuitry. Use a VTVM to make voltage and resistance measurements at these two sockets; compare the measurements with the normal values given in the technical manual and replace any defective components found to be causing incorrect values. The oscillator is not operating if its normal negative bias is not present; in this case, test-substitute a new crystal (of the same frequency) or, if frequency is LC-controlled, check the L and C components. Then test-substitute a new oscillator tube, trying a second new tube if the first replacement does not restore operation. If the oscillator functions properly but no receiver output is obtained with signal injection at the mixer grid, use an oscilloscope with sweep set to a submultiple of the			oscillator frequency to measure the amplitude and frequency of the second injection signal where applied to a grid of the second mixer.
			e.	Malfunction in IF circuitry (FOR SINGLE-CONVERSION RECEIVERS)	Insert a 0.02-volt modulated signal of the frequency last used (Step c for single-conversion and Step d for dual conversion receivers) at the signal grid of each IF amplifier and the first mixer, progressing from last IF amplifier to first mixer. Decrease the amplitude by a factor of 20 for each stage progressed. When a grid is reached from which the signal does not get through, insert the signal at the next HIGHER amplitude step at the plate just passed, using a capacitor in series to the plate terminal. If the receiver output is missing, test the condition of the IF transformer following and the components in the grid circuit of the following stage. Replace any found defective. If the receiver output is regained with signal injection at an IF amplifier plate, make

Step	Indication	Action	Step	Indication	Action
		voltage and resistance measurements at the amplifier socket, compare them with normal values, and replace any components causing abnormal values. If the grid voltage is more positive than normal, check leakage in the IF transformer, driving it by removing the tube and measuring the DC voltage developed from transformer secondary to ground. Go to Step g if the IF signal gets through to the receiver output, from the mixer plate, but not from its grid. Go to Step h if it is heard when inserted at the grid, but not at the antenna.	h.	No receiver output, but first mixer and all following circuitry known to be operative	If receiver output is not obtained at the end of Step e or g use voltage and resistance measurements at the first local oscillator socket to identify components responsible for any incorrect values found. Absence of negative grid bias indicates that this stage is not oscillating; in this case, test the condition of and correct any defects in the L and C components and switches associated with this stage. Clean the tuning capacitor plates and inspect for damage or physical misalignment. Use an oscilloscope, if desired, to determine approximate oscillator frequency and amplitude at its plate and at the mixer grid coupled to it, using frequency-determining methods described in Test Methods and Practices. E1MB NAVSHIPS 0967-000-0130. When the oscillator is functioning correctly, set the injected frequency for the maximum output indication (using as little RF GAIN as possible) to determine if the receiver is in alignment; if it is not, align each band. Then test receiver operation with the same signal applied to the antenna terminals at the 5- μ V level.
f.	Receiver output present when signal injected at output of filter, but absent when signal injected at filter input	Check FILTER IN/OUT or ON/OFF switch for correct operation. Bypass the filter with a test load and signal injected at earlier stage if an IF transformer is not part of the filter. Replace filter if this restores operation or to test filter if it includes the IF transformer.			
g.	No receiver output, but first IF transformer and all following circuitry is known operative, as tested in Step e.	If the first IF signal does not get through the mixer tube, Step e, make voltage and resistance measurements at mixer socket to identify components causing incorrect values. Replace defective components and verify that the receiver operates with the signal inserted at the mixer grid with both receiver and signal generator control settings unchanged from step e. If satisfactory operation results, make tests with injection of RF signal, according to instructions in Step h following.	i.	No receiver output, but conversion and IF circuitry are known operative	Retain the signal generator and receiver control settings used at the end of Step h and insert the signal at the plate of the last (if more than one) RF amplifier. Increase the RF amplitude to about 100 μ v. Absence of receiver output indicates that the malfunction is in the RF tuned circuit or the bandswitch; test the components involved and switch adjustment and condition. Replace

Step	Indication	Action
		components or adjust, clean, or replace the switch to correct the malfunction.
j.	No receiver output, but last tuned RF circuits and following circuitry known good	Reduce the signal generator amplitude by a factor of 20 and advance the signal injection to the grid of the last RF amplifier tube. If the signal is not present at the receiver output, make voltage and resistance measurements at the tube socket. Replace any components causing incorrect values, and if audio signal is still absent, try tube substitution
k.	No receiver output, but last RF amplifier and all following circuitry known good	Retain same settings and transfer signal injection to the plate of the preceding RF amplifier and follow the instructions of Step i for tuned circuit troubleshooting if no signal is found. Then use the procedures of Step j with the signal injected at the grid of this tube. Repeat these procedures with any additional RF amplifier stages, being certain to reduce signal amplitude by a factor of 20 for each additional stage of amplification
l.	No receiver output, but all amplifier stages known operating	If satisfactory receiver output results when the signal is injected at the grid of the first RF amplifier but not when applied to the antenna terminals, check all associated connections and switch contacts for good continuity, and especially the latter for cleanliness and adjustment. Check condition of all associated components and replace those found defective. If receiver operation is not restored by these operations, try troubleshooting by inserting the signal at various points in the antenna tuned circuit.

h. AGC AND DETECTOR MALFUNCTIONS
Automatic Gain Control (AGC) and detector malfunctions are identified by the following steps, some of which require an RF signal at the receiver antenna terminal. This signal is provided by a signal generator set for a modulated 5- μ V or 10- μ V output at the same frequency to which the receiver dial is tuned. Perform the applicable steps following in the order given and test the receiver after each change to determine if acceptable operation has been restored.

Step	Indication	Action
a.	No or low receiver output; AF signal present at detector output	Test AGC diode, detector diode, and tubes in all associated stages. Replace all tubes having internal shorts or a transconductance of less than half the normal value
b.	No or low receiver output when AGC On; tubes known good	Use VTVM to make voltage and resistance measurements at sockets of AGC and detector stages. Compare values with normal values to locate and replace components causing incorrect values. Note possible causes of high (positive) AGC voltage in Step c.
c.	No or low receiver output when AGC either ON or OFF	Measure DC voltages at AGC-controlled RF amplifier grids and IF transformer secondaries if AGC-line voltage is high-near zero or positive (see Step e of Subsection 1-8, Front-End and IF Malfunctions). The positive voltage must originate at the most positive point along the AGC line. Test quality of suspected components and replace defective ones - usually an IF transformer or tube
d.	No detector output, as determined in Step e of Subsection 1-8, Receiver Inoperative	Make voltage and resistance measurements at detector socket, locate components having incorrect values, and replace them

i. AUDIO MALFUNCTIONS
Perform the following procedures to locate and correct audio malfunctions, using, where required, a modulated 5- μ V or 10- μ V signal applied to the antenna terminals, at the same frequency to which the receiver dial is tuned. An audio generator connected to the audio gain control can be used instead if it has been established that receiver operation is satisfactory up to that point.

Step	Indication	Action	Step	Indication	Action
a.	No receiver output when signal injection at detector output as tested in Step e Sub-section 1-8, Receiver Inoperative	Test all tubes in the audio stages and replace all those having internal shorts or a transconductance less than half of the normal value	d.	No receiver output but all circuitry through output transformer primary is functioning	Use signal tracer or headset to sample the AF signal at the output transformer secondary terminals. If absent, check again with the load replaced by an equivalent resistive load. Replace the transformer if the signal is still absent and no short or open circuits are found. If the signal is absent across the dummy (resistive) load, troubleshoot the normal load by means of component substitution and inspection of the output jacks for correct contact operation
b.	No receiver output; AF output from detector known present and tubes known good	Use the signal tracer to probe for the audio signal at each of the following points and at an amplitude greater than that used at the GAIN control by the factor in parentheses: (1) AUDIO GAIN control, center tap (2) Grid of first audio amplifier (20) (3) Grid of second audio amplifier (20) (4) Grid of third and following audio amplifiers (400, etc.) If the signal is absent at a grid, test for its presence at the preceding plate. If it is not found there, make voltage and resistance measurements at the socket of that stage, locate components causing incorrect values, and replace them. If the signal is found at the plate tested previously, determine the condition of the components coupling the two stages. Remove the tube following and measure the DC voltage (for indication of leakage) on the grid side and the signal amplitude (for indication of coupling) on both sides of the capacitor.	e.	High hum level present in receiver output	Test the condition (capacity, voltage withstood, and leakage of all B-plus filtering capacitors in the receiver. If this is not effective, test all tubes and replace those with internal shorts
c.	No receiver output but AF and all preceding circuitry functioning	Test for presence of B-Plus voltage at both plate and B-plus terminals of the output transformer; replace the transformer if B-plus is applied to the transformer but is absent from the plate terminal	f.	High hum level present in receiver output; tubes and test good	Short or ground for receiver antenna input for all following tests. Vary the AUDIO GAIN control between its two extreme positions. If the hum changes in level in response to this it originates in the RF, IF, or detector circuitry. Locate the stage originating the hum by use of a 0.1- μ F capacitor to short the signal to ground at each RF and IF amplifier grid in succession, starting at the last AF amplifier. At the point where the hum disappears, the capacitor must be shunting it to ground within the stage following its source. Check all components in this stage and replace that introducing the hum—usually a tube filament-to-cathode short, which may appear only when the tube is hot. Tube substitution will be necessary

Step	Indiction	Action	Step	Indication	Action
		to identify this cause. Lead dress may be critical and can be experimented with if it has been previously altered			is not effective, return the original tube to the socket and tap each associated component under the chassis to find the one that is sensitive to vibration. Typical causes are microphonic tubes, poor electrical connections, and occasionally defective components
g.	High hum level originating in AF circuitry present in receiver output	If the hum level was unchanged by variation in AUDIO GAIN setting, the hum originated in the circuitry following the volume control - the AF circuitry. Use the methods of Step f to locate stage in which the hum originates			
h.	Intermittent noise present in receiver output	Lift one side of the energized receiver (with the antenna shorted) a quarter of an inch above the work bench surface and let drop. If no change in intermittent noise results and if noise is constant in occurrence, follow the procedures of Step f and g to locate the stage and component causing the noise			
i.	Intermittent noise present in receiver output in response to mechanical vibration	If dropping the side of the receiver slightly in step h. previously altered the noise momentarily, locate its origin by varying the AUDIO GAIN setting as in step f previous. If increasing the setting increases the volume of noise, use a small (one-fourth diameter) alignment tool to gently tap each tube in succession, beginning with the first RF amplifier and ending at the last IF amplifier. In evaluating intermittent noise, bear in mind that the tube characteristics for front-end applications result in microphonic effects, which are amplified by the stages following. Tap each tube at least once from directions 90 degrees opposed. Test-substitute a new tube for one producing a high level of intermittent noise. If this			
			j.	SYNCHRONOUS COMMUNICATION RECEIVERS	
					Communication requiring close synchronization of transmitter and receiver frequencies (such as SSB, ISB, FSK, and MUX) can be accomplished using any of the following three means of reception:
					1. A conventional communications receiver having adequate BFO power, AGC adapted to suppressed-carrier reception, narrow-band selectivity, slow tuning rate, and stabilized oscillators.
					2. A conventional receiver used in conjunction with a terminal unit which accepts the receiver IF and supplies sideband selection and filtering, injected carrier, and AFC where required.
					3. A specialized synchronous communication receiver having frequency-setting precision and stability which permits reception at the synchronous frequency without requiring special tuning indications or having any subsequent frequency drift.
					Malfunctions in conventional receivers can be identified and corrected by use of procedures given previously. Many of these procedures are useful in SSB troubleshooting also; those following can be used without change:
					1. Receiver Inoperative.
					2. Single-Band or Single-Channel Malfunctions.
					3. AGC and Detector Malfunctions.
					4. Audio Malfunctions.
					The previous steps should permit troubleshooting all of the specialized SSB receiver except for frequency synthesis, comparison and control; heterodyning; and detection circuitry. Analysis of any frequency generation and control malfunctions or use of the SSB troubleshooting procedures, will determine what further procedures should be used. Some of the RF Oscillator or Frequency Source Malfunction procedures in the Transmitter section of this chapter will be useful in troubleshooting the SSB receiver frequency generation circuitry. These procedures are listed following and are referred to in Subsection 1-8, Single-Sideband Receiver Troubleshooting.
					1. RF Output is Unsatisfactory on Only One Band or Channel.
					2. RF Output is Absent From Frequency Source.
					3. Output of Frequency Source is Too Low in Amplitude.
					4. Output of Frequency Source is Off Frequency.
					5. Frequency Errors Originating in Frequency Synthesizer.
					6. Frequency Control Circuit Malfunctions.

(1) Principles of Single-Sideband Reception

The characteristics of the single-sideband emission are given in Subsection 1-2, Types of Emission. In A3 communication, audio intelligence is detected as simultaneous beat frequencies between the carrier and the many radio frequencies forming the sidebands, but in SSB transmission there is no carrier and hence no beat notes. The simplest means of obtaining SSB reception is by using a conventional receiver, which supplies a beat oscillator frequency as a "substitute carrier" to beat with the sideband frequencies. This "substitute carrier" is inserted as an intermediate frequency, and diode detection is used. Unfortunately, there is no such thing as an "exact" frequency setting on most such receivers, and the best oscillator frequency requires periodic resetting to retain intelligibility.

These inadequacies of the conventional communications receiver are retained when a single-sideband converter is used in conjunction with it. Tuning precision and frequency stability are limited by dial readability and local oscillator stability, although sideband tuning and filtering are improved with use of the converter.

Recent receivers designed specifically for SSB reception incorporate elaborate means for frequency selection, control, and compensation. Some of the more common are:

1. Use of a crystal oscillator and selection of frequency-dividing and frequency-multiplying circuits to produce reference signals at the desired frequencies.
2. Enclosing temperature-sensitive, frequency-determining circuits in an extremely stable crystal oven.
3. Use of frequency comparison circuitry to compensate for error or drift of the individual injection frequencies.

Many of these equipments obtain heterodyning frequencies from phase-lock oscillators, the frequencies being compared with and maintained at the selected reference frequencies.

Local oscillator stability is increased by using step-type LC selection of harmonics of stable frequencies, which are obtained by division of a crystal-controlled frequency. This fundamental frequency can easily be calibrated by comparison at a test point with a Ships Standard Frequency or WWV transmission. The accuracy resulting is far greater than could be obtained by continuously variable or step-type LC control of the oscillator. In some equipments, the desired frequencies are set by switching, the local oscillator tuned to the identical frequency, and error- and drift-compensating circuitry used in the generation of a heterodyning frequency to keep the total of the beat frequencies stable. The step-type control permits the receiver to be set to a scheduled frequency, rather than tuned to a received signal.

Single-sideband RF signals can be obtained in one method, by phasing processes resulting in the suppression of the carrier and one sideband. Balanced modulators can be used in a more common method since they obtain the difference and sum frequencies but exclude the input frequencies from the output. The desired sideband can be retained by filtering after the balanced modulator in a transmitter; this sideband is selected by filters before demodulation in a receiver, but the balanced

modulator itself is the same in both applications. Several such balanced modulators can be used in specialized SSB receivers for obtaining successive sum and difference frequencies, as shown in Figure 1-24. The final frequency injected restores the carrier; no additional demodulation stage is needed.

(2) Alignment Adjustments on Single-Sideband Receivers

Single-sideband receivers have RF and IF alignment adjustments that are similar to those of the conventional superheterodyne receiver, in addition to those required for SSB receivers only. These additional adjustments are injection oscillator amplitude, modulator balance, sideband selection filters, and the source frequency. Oscillator frequency adjustment to retain dial calibration may be required as a result of normal component aging and following replacement or replacement of an associated component, to minimize any input frequencies appearing in the output.

The functional block diagram of one type of SSB receiver front end is shown in Figure 1-25. Note that the desired frequency is selected by setting the proper reference frequencies and then tuning the associated oscillators to each component of the reference frequency by means of tuning indicators. The RF circuits, first (HF) oscillator, and harmonic selector filter are ganged together in such equipments, requiring precise alignment for good tracking. Some equipments make use of a variable IF frequency, with the added requirement that the variable IF transformers be aligned to track with the ganged components noted previously.

(3) Single-Sideband Receiver Troubleshooting

The following procedures are to be used in troubleshooting specialized SSB receivers. They refer, where appropriate, to steps used in troubleshooting conventional receivers.

Test equipment of precision and stability comparable to these receivers should be used in making alignment and calibration adjustments. Frequencies can be measured by means of an electronic counter (EPUT counter) calibrated as a secondary standard.

Use the appropriate following steps in case of malfunction, testing the operation of the receiver or the defective stage after making any change or adjustment.

Step	Indication	Action
a.	Receiver inoperative	Follow appropriate steps of Subsection 1-8, Receiver Inoperative, except in Step e substitute the steps following for those of the Subsection 1-8, Front-End and IF Malfunctions, reference. Step c, tube testing, may be deferred if receiver has many tubes, and none are obviously defective.
b.	Operation on one band or channel(s) absent or impaired.	Follow appropriate steps of Subsection 1-8, Single-Band or Single-Channel Malfunctions.

ORIGINAL

1-59

COMMUNICATIONS

NAVSEA 0967-LP-000-0010

GENERAL

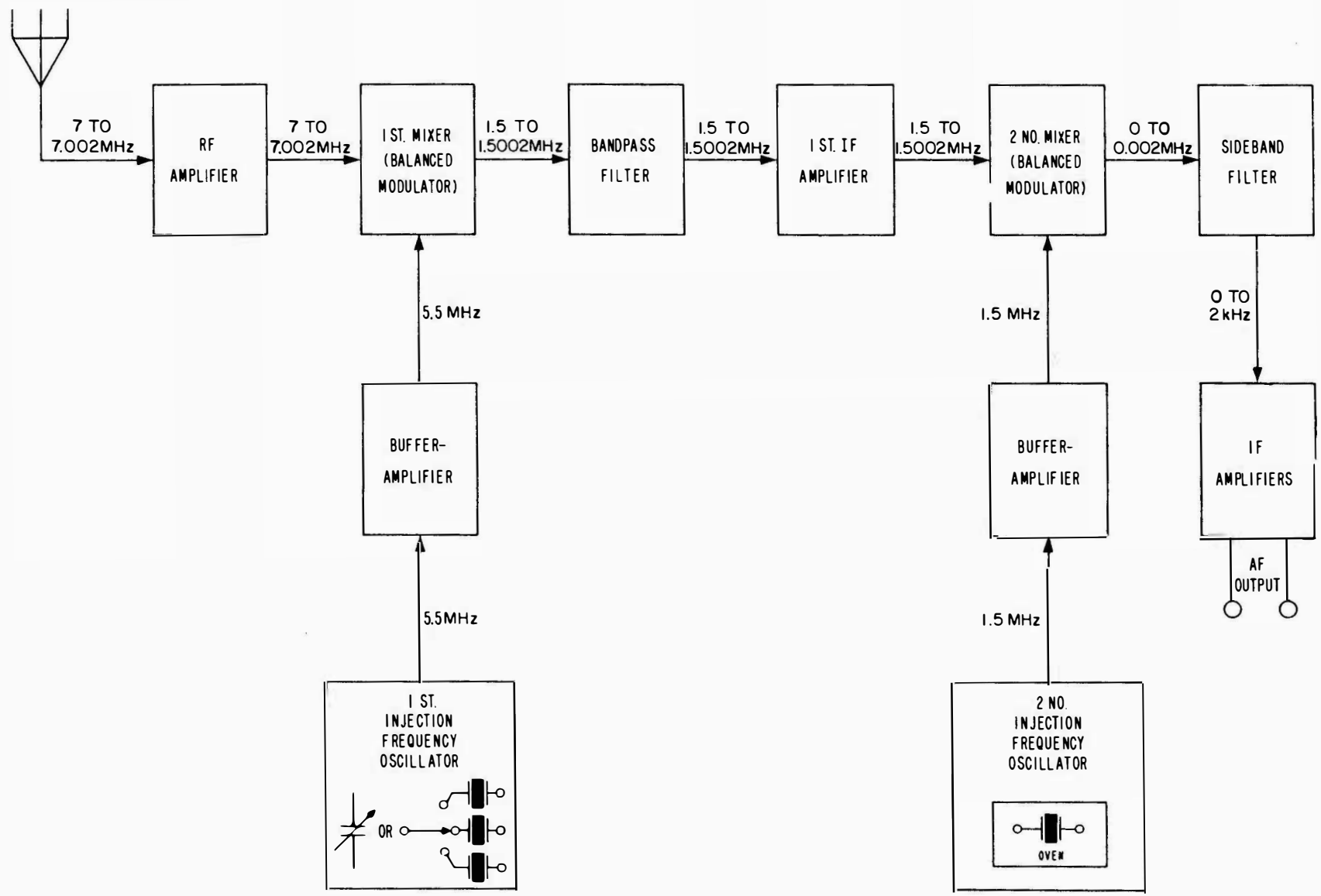

Figure 1-24. Single-Sideband Receiver, Block Diagram

ORIGINAL

1-60

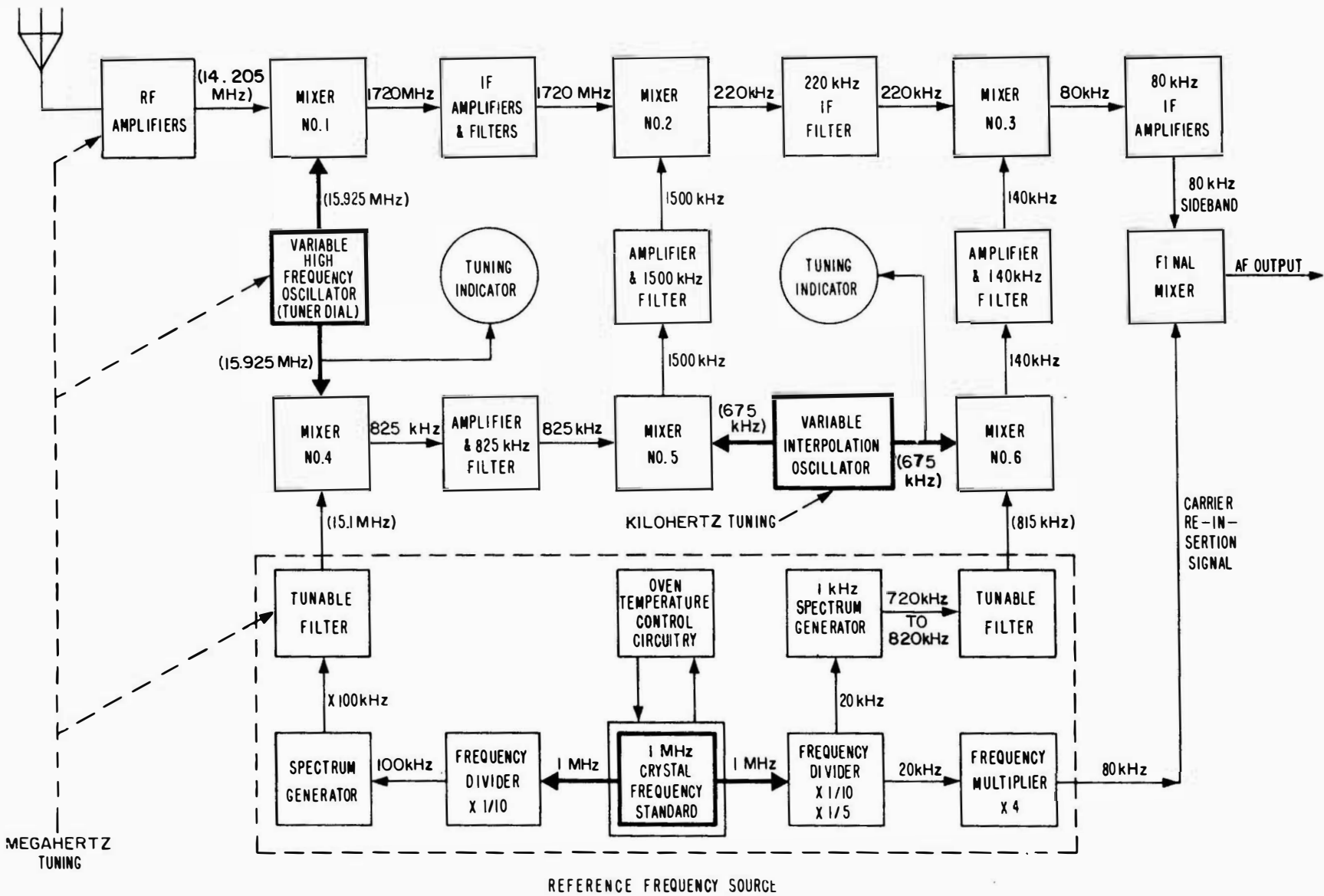

Figure 1-25. SSB Receiver Front End Using Frequency Synthesizer as Frequency Reference

COMMUNICATIONS

NAVSEA 0967-LP-000-0010

GENERAL

Step	Indication	Action	Step	Indication	Action
c.	Receiver output is absent or impaired; input meter gives normal indications, but output meter indication is low or absent	Follow the appropriate POMSEE step to determine the condition of the receiver AF circuitry. If no such step is found, inject a 0.5-volt AF signal at the center tap of the AUDIO GAIN control; receiver AF circuitry is operative if normal receiver output is obtained. Proceed to Step d if AF operation is satisfactory. Use steps given in Subsection 1-8, Audio Malfunctions, to identify and correct the cause of any audio malfunction found.			Use an oscilloscope with horizontal sweep triggered by an accurately calibrated oscillator to determine (by use of Lissajous patterns) the injection frequency. Trace it from the oscillator to the grids of the associated modulators or mixer used. If the injection signal is absent, use the appropriate troubleshooting procedures of Subsection 1-6, RF Oscillator or Frequency Source Malfunctions. If it is not at the correct frequency, make the required adjustment.
d.	Receiver output is absent or impaired, but AF circuitry is known to be functioning correctly.	Set an RF signal generator for a 0.5-volt unmodulated carrier output at a frequency differing from the receiver's last intermediate frequency by an audio beat. Apply this signal to the grid of the first IF amplifier preceding signal demodulation. (If necessary, swing the generated signal across the known intermediate frequency until tuning setting is found.) If normal output is present, test preceding IF stages of this frequency by applying the signal (reduced in level by a factor of 15 or 20 for each stage) to each preceding grid in turn. Proceed to Step e if indications of normal reception are found. Use techniques of tube testing or tube substitution, signal tracing, tube socket measurements, and measurement comparisons to locate the point where the signal is lost or impaired. Use Step c of Subsection 1-8, AGC and Detector Malfunctions, if AGC-controlled grid voltage is too high.	e.	Receiver output is absent or impaired, but AF and last IF circuitry are known to be functioning correctly.	Set the signal generator to the next-to-last intermediate frequency used, output unmodulated and attenuated by a 1/20 factor for each amplification stage. Inject this frequency in turn at each grid having such an input. Proceed to Step f if normal indications are found when receiver is operated. If the normal signal is absent or impaired at any grid tested, follow the procedures of Step d to test for the presence of the required heterodyning injection frequency and to test the circuitry involved.
			f.	Receiver output is absent or impaired, but receiver is operative from the next-to-last IF stage onward.	Set signal generator to any further intermediate frequency used, unmodulated output, and a level determined by the number of amplification stages following the injection point. Use the test procedures and corrective measures given in preceding Steps d and e to correct any malfunctioning.

Step	Indication	Action
g.	Receiver output is absent or impaired, but is known to be operative from first IF stage onward.	Use Lissajous-pattern presentation to determine the first injection frequency. Adjust the signal generator for a frequency having an audio difference from the frequency to which the receiver is tuned (unmodulated and at a 100- to 1000- μ V level) and inject it at the grid of each RF amplifier in turn, progressing from the first balanced modulator or first mixer to the receiver antenna input. Use general malfunction-isolating procedures given previously to identify malfunctions in the area where the injected signal is lost. Do not overlook the condition of switch contacts or RF inductors.

1-9 REMOTE CONTROL UNITS

Remote control units are used to control transmitters and receivers from remote phone or telegraph stations. The transmitter and receiver are tuned at the equipment location and only POWER (transmitter B-plus power), CARRIER ON (transmitter busy), and receiver muting switching are controlled from the remote units.

The troubleshooting procedures following are intended for use with the most commonly used Controls, Radio Set C-1138/UR and C-1207/UR, and consequently refer to voltages and terminals found in these equipments. This has been done to enable them to be as useful as possible; the procedures can be applied to other similar equipments if the correct voltages and terminal designations are used.

a. PRELIMINARY MALFUNCTION VERIFICATION

Since this equipment is used by many persons, the electronics technician maintaining it may wish to verify the symptoms of units reported malfunctioning. The following quick-check procedure can be used for this purpose. It requires the presence of a man at the remote unit and another at the controlled equipment, with telephonic communication between them or use of a prearranged sequence and timing of test steps. The transmitter need not be on the air but should be energized to an extent enabling it to indicate when it is keyed or modulation is applied.

Step	Operation at Remote Unit	Correct Indication at Remote Unit	Correct Indication at Controlled Unit
a.	Depress START switch for 3 seconds	POWER indicator energized	POWER indicator energized (B-plus applied to transmitter)
b.	Depress handset push-to-talk switch (for phone operation)	CARRIER ON indicator energized and associated loudspeaker amplifier muted	CARRIER ON indicator energized and carrier transmitted in normal operation
c.	Operator telegraph key (for CW operation)	Receiver output muted during key-down intervals	Transmitter keyed and carrier transmitted in normal operation
d.	Talk into handset transmitter with push-to-talk switch still depressed	Loudspeaker amplifier muted as in Step b.	Modulation during normal operation
e.	Release push-to-talk switch	CARRIER ON indicator deenergized and associated amplifier demuted	CARRIER ON indicator deenergized and transmission stopped during normal operation
f.	Depress STOP switch	POWER indicator deenergized	POWER indicator deenergized (B-plus removed from transmitter)

b. INDICATOR AND CONTROL TROUBLESHOOTING

Use the appropriate steps among the following for malfunction in the indicator and transmitter control circuits until proper operation is restored or the malfunction identified.

Step	Indication	Action
a.	POWER indicator and/or transmitter cannot be energized	Replace bulb if burnt out. Determine condition of START switch. Measure 115/230V AC input to remote unit at terminals 2 and 4 of TB101 or E102. Make sure that POWER indicator series resistor is not jumpered for 230-volt operation.
b.	No 115/230 VAC power input present	Test for presence of power at transmitter. Test for power at switchboard (if any) Test wiring and connections for continuity.

ORIGINAL

1-63

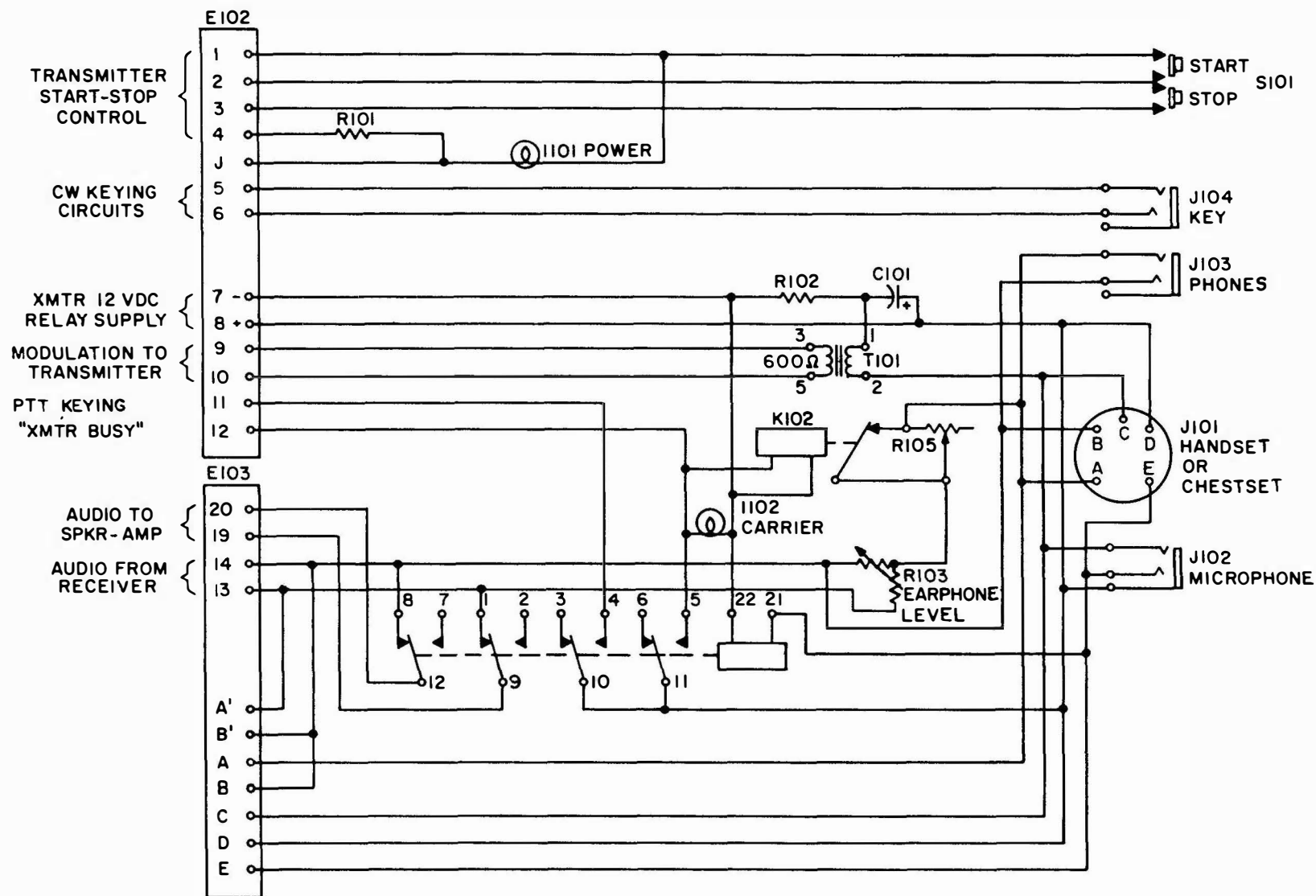

Figure 1-26. Wiring Diagram of Typical RPU, C-1138/UR.

COMMUNICATIONS

NAVSEA 0967-LP-000-0010

GENERAL

Step	Indication	Action
c.	POWER indicator energized only while START button depressed	Check transmitter power relay for coil continuity and contact condition
d.	POWER indicator and/or transmitter not deenergized when STOP button depressed	Determine condition of STOP switch. Check continuity of STOP switch wiring to transmitter. Determine condition of power relay coil shunting resistor. Check adjustment and condition of power relay; clean and adjust if necessary
e.	CARRIER ON indicator cannot be energized	Replace bulb if burned out. Measure voltage at terminals 7 and 8 of TB 101 or E102 (should be 12VDC)
f.	12VDC not present at remote control unit	Check for presence of 12VDC at transmitter. Check for presence of 12VDC at switchboard. Check wiring and connections for continuity
g.	CARRIER ON indicator not energized by 12VDC present at remote control unit	Check contacts and action of handset push-to-talk switch. Check remote unit relay coil continuity, action, and contact condition
h.	CARRIER ON indicator and/or transmitter. RF output not deenergized when handset push-to-talk switch released	Check adjustment of handset push-to-talk and holder switches. Clean and adjust armature gap and contacts of CARRIER ON muting relay.

c. HANDSET TRANSMITTER (MICROPHONE) TROUBLESHOOTING

Use the appropriate steps among the following for malfunctions in the handset transmitter circuits, until proper operation is restored or the malfunction identified.

Step	Indication	Action
a.	No handset transmitter output at terminals 9 and 10 of TB101 or E102 (should be approximately 4V RMS when push-to-talk button depressed and microphone spoken into)	Check terminals 2 and 4 of TB101 or E102 for presence of 12VDC. If not present, check source of 12VDC (in transmitter) and continuity of connecting wiring and terminals
b.	No handset transmitter output, but microphone supply voltage present	Measure DC voltage across audio transformer primary and across microphone

Step	Indication	Action
		with equipment energized, POWER ON, handset removed from holder, and push-to-talk switch operated. Each of these voltages should be between 4 and 8VDC and their sum equal to the input voltage.
c.	12VDC measured across audio transformer primary during operation in Step b.	Replace the transformer if use of an ohmmeter verifies that the transformer winding is open
d.	12VDC measured across microphone during operation in Step b.	Test all connections and switch contacts in operating position for continuity to microphone. Clean and adjust if required. Replace microphone if its DC resistance (as measured by an ohm-meter) exceeds 60 ohms or is less than 20 ohms.

d. HANDSET RECEIVER (EARPHONE) TROUBLESHOOTING

Use the appropriate steps among the following for malfunctions of the handset receiver circuits, until proper operation is restored or the malfunction identified.

Step	Indication	Action
a.	Handset receiver inoperative	Verify that the earphone level attenuator is at its maximum clockwise rotation and the radio receiver is operating. Measure the AC (audio frequency) voltage at terminals 13 and 14 of TB102 or 103. Measurements of up to 15V RMS are normal, depending on the radio receiver audio gain setting.
b.	No AF input to remote unit	With radio receiver still operating, disconnect the input leads to terminals 13 and 14 of TB102 or 103 and again measure the signal across these leads. If there is still no input, check the radio receiver for output at the desired level, AF connections and switching, and continuity of the audio distribution wiring to the remote unit

Step	Indication	Action
c.	Handset receiver inoperative, but AF input is present at remote unit	Determine condition of earphone level control and replace if defective. CARRIER ON muting relay should not be energized; if it is, inspect handset holder switch for contact condition and adjustment, cleaning and adjusting if necessary. Verify that radio receiver output is present at terminals A and B of handset holder switch.
d.	AF signal is present at terminals A and B of handset holder switch in either position, but no receiver audio output heard	If the handset holder switch has been inspected for correct switching action, check the handset receiver and wiring for open circuits; replace the receiver if defective
e.	Radio receiver output measured at terminals A and B of handset holder switch only when handset is in holder or handset receiver disconnected.	Check the handset receiver and wiring for a short circuit and replace the receiver if it is found defective

e. TROUBLESHOOTING THE OUTPUT TO LOUDSPEAKER AMPLIFIER.

Use the appropriate steps among the following if the remote control unit output to an external amplifier appears to be malfunctioning.

Step	Indication	Action
a.	Apparently no AF output from the external loudspeaker amplifier driven by the remote control unit	Leave handset in holder after verifying, as in Subsection 1-9, Handset Receiver (Earphone) Troubleshooting, that the proper earphone input is present. Measure the AC voltage between terminals 13 and 14 and terminals 19 and 20, TB102 or E103. If the voltages measured are approximately the same, measure the voltage across terminals of the loudspeaker amplifier. If essentially the same value is measured there, the remote unit is not causing the malfunction; continue troubleshooting the amplifier

Step	Indication	Action
b.	AF signal found at output of remote unit but not at input to associated loudspeaker amplifier	Inspect the connections and wiring between the amplifier and the remote control unit for continuity and absence of short circuits.
c.	AF output can be measured at terminals 19 and 20 of TB102 or E103 only when leads to associated amplifier are disconnected	Measure the signal at the amplifier end of the amplifier end of the interconnecting wiring to the remote unit and receiving a signal. If the signal is absent, check the line for an open circuit. If the signal is present at the amplifier end, troubleshoot the amplifier input circuitry
d.	AF voltage across terminals 13 and 14 is not the same as that across terminals 19 and 20, TB102 or E103, when handset is in holder	Inspect the CARRIER ON muting relay to make sure that it is not energized. Adjust the handset holder switch contacts if the relay is energized. Adjust the relay contacts if the relay is unenergized; normally closed contacts C and D should be making good contact. After corrective action, verify that the signal input to terminals 13 and 14 appears at terminals 19 and 20
e.	Associated loudspeaker amplifier not muted when push-to-talk switch is depressed	Adjust contacts C and D of CARRIER ON relay so that they are closed when the relay is unenergized and open when the push-to-talk switch is depressed. If the relay cannot be energized, check its coil for continuity, the D and E contacts of the handset holder switch for good condition and correct adjustment, and the handset push-to-talk switch for good condition and correct adjustment. Clean, adjust, or replace as necessary. Verify that the relay is energized when the handset is held and the push-to-talk switch depressed

Step	Indication	Action
f.	Associated loud-speaker amplifier not muted when push-to-talk switch depressed, but switch and relay action is satisfactory	Attempt to secure desired muting action by adjustment of the speaker muting control. If this is not effective, measure the resistance of these dual potentiometers; replace them if this value is not correct

f. AUDIO DISTRIBUTION LEVEL OF TRANSMIT-RECEIVE PANELS AND REMOTE CONTROL UNITS

The standard audio level for distribution aboard ships is 0.775 volts in 600 ohms. This is a meter reading of -7.8 dB of audio in the systems which use the older 6 mW reference level, and a 0 dBm reading in the newer VU system which uses 1 mW as a reference level. All devices which receive inputs via the audio distribution panel are designed to operate at this level, and therefore all receivers supplying audio should be adjusted accordingly. Many terminal units can tolerate a slightly higher input, but at a risk ranging from distortion to physical damage. For example, a receiver delivering +20 dB above the prescribed output is producing almost 8 volts of audio. It is obvious what can happen when 8 volts is applied to a device intended to operate at about 0.775 volts.

Some of the expected consequences of excessively-high audio are listed below. How many do you recognize as malfunctions in your installation?

1. Signal distortion in Remote Phone Units and TTY Terminal Units.
2. Uncontrollable feedback howl when using a standard Navy handset at a Remote Phone Unit.
3. False triggering of TTY Terminal Units on noise.
4. Crosstalk between audio distribution circuits.
5. Burning out of receiver output transformers, or of terminal unit input transformers. TTY mark-space filters are frequent victims of excessive audio.

Shipboard audio distribution is on twisted-pair wires, usually terminated at each end in 600-ohm transformer windings, of which the center tap is grounded at the receiver end only. Both audio leads are "hot," so care must be exercised to avoid grounding either of them (at phone jacks or terminal boards for example). A ground on one audio leg shorts one-half the receiver output transformer, with a possibility of transformer burnout. When non-standard equipments are routed through the audio distribution panel (TCS, aircraft gear, and vehicular or portable equipments for example) they must be modified to ungrounded or center-tap grounded audio in order to make them compatible with the standard Navy audio distribution system.

g. AUDIO LEVEL CONTROL AT RPU'S

Much of the fleet tactical communication is accomplished over voice circuits. The nature of these circuits requires that several users, usually physically separated, have access to the same circuit. This access is provided at each user station by one of three remote control circuit arrangements having transmitter

control capability. The three arrangements are:

Type 1: Radiophone control units (RPU's) with transmit-receive handset. This type of RPU usually has an associated speaker-amplifier. Output level control is provided for receive only. No gain control or amplification is provided for transmit. Figure 1-26 is a complete wiring diagram of a typical Type 1 RPU.

Type 2: Master communications console. RPU with transmit-receive handset having access to 16 different circuits. A variable gain amplifier delivers the modulation signal to the transmitter.

Type 3: NTDS console. Receiver earphone and boom microphone. Modulation circuit provided with a constant gain amplifier of about 10 dB gain. Transmitter keying accomplished by a foot switch. Access to 10 different circuits provided by a local console switch.

One of the common problems associated with these remote circuits is that of unequal audio output level. Variation in RPU modulation output level can vary the transmitter output for each of the different users controlling the same circuit. When the various user stations controlling a given circuit are comprised of various remote arrangement types noted above, the problems can be seriously compounded unless some effort is made to assure that the same audio level is provided by all user stations.

Each transmitter supplies 12 VDC to all user stations which control it. This supply operates the keying and muting relays in the remote control unit, provides bias for carbon and transistor microphones, and illuminates the "Transmitter busy" lamp (misnamed "Carrier on" lamp) at all user stations for that transmitter. If a ship has a combination of the various types of remotes, it will be necessary to adjust the type 2 and type 3 remotes to give the same audio output levels as type 1. There are a number of ways this could be done. Whatever system is used, it may happen that the audio output of a remote will vary because of variations in the 12 VDC voltage supplied by the different transmitters and also with the type and condition of the microphone connected to the remote. When measuring and adjusting outputs of the remote units, they should be individually connected to the same transmitter. The microphone used with the remote should be the same that is normally used with that particular remote, and it should be tested to ensure that it is operating correctly. If the remote does not have a controllable output, an attenuating pad made from resistors in a "T" arrangement can be used.

Many ships have made a test jig for testing radio remote handsets. In its simplest form, the jig contains an outlet jack and provides the proper relay/mike/lamp voltage, proper termination, and an output meter to measure the microphone output level. The "output" function of a PSM-4 meter can be used. The addition of an audio oscillator would permit a simultaneous check of the earphone of handsets. More elaborate test jigs could contain a cradle for the microphone that provides a fixed audible input at a fixed distance for precise measurements of microphone response.

Audio input circuitry in a transmitter is designed to regulate variable inputs in the range of about 20 dB (refer to Modulator Adjustments in Subsection 1-8). Inputs can easily fall outside this range because of excessive variations of audio output levels from radio remote units, improper setup of transmitter equipment,

or malfunctioning or misadjustment of equipment. The transmitter technical manual should be consulted for guidance in setting modulation levels.

For those transmitters which use a local microphone for setting modulation levels, there is an additional precaution: after all remotes are connected to the transmitter, there may be a drop in the 12 VDC voltage when one unit is keyed. If a large number of remotes are used, the transmitter modulation should again be checked after all remotes are connected to the transmitters and the operator at the primary control station is sending traffic. If the transmitter is modulating correctly, then no attempt should be made to readjust the transmitter audio input controls. If the transmitter is not modulating correctly, the technical manual procedures for modulation adjustments should be tried again. If this still does not improve operation, then audio level controls should be adjusted and a technician notified that there are indications of improper transmitter or remote station operation.

It is possible for the remote control unit to modulate improperly even if the proper transmitter adjustment procedures are followed. One fault could be poor regulation of the relay/bias voltage. This will happen especially when the 12 VDC rectifier is of the selenium type. Another fault could be the adjustment of the transmitter audio input amplifier to accept signals from -10 dBm to +15dBm when the actual values of signals range from -25 dBm to -5dBm.

Losses in audio line lengths used in shipboard installations normally do not significantly affect the modulation voltage amplitude unless there are faulty terminal connections or damaged lines. All remotes should provide the same audio level unless the microphone or RPU impedances are significantly different. A substantial change in a remote handset microphone impedance because of compacted carbon granules is not uncommon. If it is established that one RPU of several on a circuit produces a low audio modulation level where all user stations are of type 1, the handset mike is first suspect, a bad line second, and finally the control unit itself.

The practice of connecting many receiving monitor outlets to a single circuit can seriously degrade the primary station's receiving capability. Measurements made during BASE LINE II indicated that when four RPU's with handsets and amplifiers were connected into a single circuit the received signal was significantly attenuated below that when a single RPU with handset terminate the circuit.

Pre-exercise examination and operational observation of audio circuits indicated that lack of a preventive maintenance program contributed significantly to improper and unequal audio levels. Where line losses were significant, they were due to bad terminal connections or partially open leads. Where objectionable degradation of receiving capability occurred, the number of users terminating the circuit was usually excessive. Other causes of degradation of receiving capability was that the AGC circuits of the receiver were not used, and that RF and AF gain controls were both set for maximum, thereby delivering excessive and unregulated audio levels into the distribution system.

Crosstalk between audio lines aboard ship can cause problems. To prevent crosstalk, the audio lines aboard ship are of the "balanced" type. This means that neither wire of the audio pair is directly

grounded. Normal installation practice is for only the center tap of the receiver output transformer to be grounded. Remote control units and speaker amplifiers are designed with center tap input transformers, but center tap should not be used. With balanced audio lines, any current induced into one line is also induced into the other and these currents will cancel themselves as they proceed from opposite ends of a transformer to center ground. This arrangement will provide isolation of approximately 60 dB if there are no inadvertent grounds on the audio lines. If one side of the audio line is grounded, the line will still be partially functional because of its balanced nature, but it will be subject to severe crosstalk. Audio lines should be checked for inadvertent grounds. This can be done by taking resistance measurements to ground at the audio distribution board. A receiver should show equal resistance to ground, and a remote position should show no ground at all. Pieces of solder, wire, and miscellaneous hardware falling into the audio distribution panel or RPU are known to cause many shipboard problems. Another common cause is improper wiring of the radio remote units and speaker amplifiers.

A maintenance program which includes audio distribution lines and receiver output level adjustment should eliminate crosstalk, feedback, and poor modulation problems. (EIB 740)

1-10 TERMINAL EQUIPMENT

Terminal equipment is needed to enable special types of signals to modulate radio transmission and, at the receiving end, to enable receiver outputs to operate monitoring and recording devices. Its most common use is to modulate radio transmissions by the start-stop, pulse-type code used by teletypewriters and, at the receiving end, to transform the signal received back into the start-stop code.

Basic troubleshooting procedures are given in this section for the keyers (transmitting) and the converted and converter-comparators (receiving) used for teletype FSK (frequency-shift keying on F1 emissions) and facsimile (on F4 emissions) communication. Local distribution systems and power supplies are described briefly, but electronic cryptographic equipment is not covered.

Because of the unrelated natures of terminal equipment, this section is divided by equipments. In troubleshooting terminal equipment, use the steps given for the particular symptoms noted under the equipment being serviced. Test the equipment either partially or in its entirety after any repair or adjustment is made.

a. TELETYPE AND FACSIMILE KEYERS

Keyers are used to transform the on-off (neutral) or plus-minus (polar) teletype signal into F1 (frequency-shift keyed RF signals, the frequency shifts occurring in response to changes in level of the teletype signal. The keyers in use can accept an RF signal from an external source, usually a transmitter, or can generate their own crystal-controlled RF. The keyer output can be used to drive any RF stage of the transmitter requiring a 20-volt AC signal.

Many keyers can modulate in response to voltage variations between the extremes of teletype signal levels, as well as at the extreme levels only. These keyers can be used, in conjunction with a keying

adapter, for F4 transmission of facsimile signals. The keying adapter transforms the modulated 1800-Hz facsimile transmitter output into a direct current of varying voltage. This voltage is applied to the keyer input for further handling in the same manner as F1 signals. If satisfactory F4 transmission is not obtained during initial operation, the technician should first verify that the equipment used is compatible and that the correct switch and dial settings have been made.

Use the appropriate steps from among those following to identify and correct any malfunctions found in keyer equipments. It is assumed that all indicators (panel lamps and meters) are functioning correctly.

Step	Indication	Action
a.	Equipment not energized when POWER ON indicator lamps do not light	Inspect and if necessary, repair power cord and plug. Inspect fuses and replace any blown. Verify that power is present in line. If equipment is still inoperative, follow the procedures in Subsection 1-7 Power Supplies
b.	POWER indicator lamp lights but PLATE indicator does not, nor does PLATE CURRENT meter deflect	Inspect the plate fuse and replace it if blown. Following the troubleshooting procedures in Subsection 1-7, Power Supplies
c.	Equipment has no or low RF output 1. If malfunction exists only when RF input used 2. If needed RF input is supplied 3. No or low RF output	Verify that control settings are correct Test complete operation of keyer. Inspect the input selector switch for condition, action, and adjustment; inspect all connections. Test for presence of RF input Troubleshoot RF source and connectors Test or test-substitute the RF output tube. Test or test-substitute the oscillator tube. Test all tubes in the equipment and replace those having internal short circuits or low transconductance. Use an oscilloscope of suitable frequency characteristics to trace the RF signal from the oscillator (or RF input) to the output stage. Use tube socket voltage and resistance measurements at the stage where the signal is lost in

Step	Indication	Action
		order to locate defective components; replace them
d.	Output has only one condition, either SPACE or MARK	Determine if both MARK and SPACE levels are present in the input signal, using a calibrated DC oscilloscope. (Sweep speed used is not critical, since only the presentation of two parallel lines is essential.) Verify that keyer is set for the type of signal (neutral or polar) supplied
	Input has only one signal level	Troubleshoot the signal source, local loop power supply, and local loop continuity
	Both MARK and SPACE levels present in signal but only one frequency present in output	Test or test-substitute the following tubes: pulse limiters, amplifiers, reactance tubes, and output tubes. Use the oscilloscope to trace the input signal to where keying or the RF is lost
e.	Frequency shift is too wide or narrow	Verify that MULTIPLIER or XMTR MULT FACTOR switch indicates the frequency multiplication occurring in the transmitter. Verify that the FREQ SHIFT or DEVIATION setting is correct. Use a frequency meter or frequency shift monitor (such as the OCT-2, -3) to measure the radio frequencies at the MARK and SPACE conditions.
	Deviation obtained does not conform to dial scale indication	Calibrate the DEVIATION control, using procedures given in the Corrective Maintenance section of the equipment technical manual
f.	RF output drifts from original setting	Verify that equipment POWER is kept ON at all times so equipment can be energized immediately by operating PLATE switch to ON. Verify that the oven is at the correct temperature (60° or 70° C. for some equipments, correct value given in the technical manual) and that OVEN indicator lamp cycles on and off properly

Step	Indication	Action
	Thermometer indicates incorrect oven temperature	Adjust oven thermostat contacts according to directions in the technical manual. Replace any oven-heating resistors found defective
	Thermometer indicates oven temperature variation	Inspect condition of thermostat contacts; use burnisher to smooth contact surfaces if necessary
g.	RF output frequency incorrect	Verify that the 200-kHz signal is correct; if not, adjust the 200-kHz oscillator
	1. If external RF source used	Troubleshoot the external RF Source
	2. If keyer crystals are used	Measure crystal oscillator output frequencies. (Each should be 200 kHz below the desired RF output frequency.) If these steps are not effective, follow the appropriate steps in Subsection 1-6, RF Oscillator or Frequency Source Malfunctions

b. TELETYPE CONVERTERS

A teletype signal at the output of a communications receiver is composed of coded pulses of two audio frequencies. In order to control the teletype receiver, the pulses must operate a device which keys the current in a local teletype loop, either mechanically or electronically. Such a device is called a converter.

In many cases, either space-diversity or frequency-diversity reception is used at least part of the time to insure reliable communication. Such a setup requires two receivers and therefore two converters, with a comparator to select the best signal from the two available at each instant. Because of their close association, the comparator and the two converters are usually supplied together as a frequency-shift converter-comparator group.

Each of the following steps gives instructions for identifying the cause of a specified type of malfunction in converters and comparators. Use the steps appropriate to the equipment affected and the symptoms noted. Steps a and b are for power supply malfunctions, step c is for determining the location and extent of malfunctions, and the remaining steps are for troubleshooting specific symptoms. It is assumed that all indicators are functioning correctly (panel lamps not burned out, for instance).

Step	Indication	Action
a.	A converter or the comparator cannot be energized and neither power indicator nor tubes light up	Verify that the POWER switch is ON. Check the fuses (with chassis withdrawn) of the malfunctioning unit. Inspect condition of power

Step	Indication	Action
		cable and connectors, from power line to the comparator if the comparator or all three units are inoperative or from the comparator chassis to the affected converter. Check the input voltage compensation connection (under chassis and adjacent to the power transformer). Verify that primary power is present at the transformer
	If primary power is not present at transformer	Check continuity of primary power leads from transformer through switch to power input.
	If primary power is present at transformer but equipment is inoperative	Check the cable filter for continuity. Make voltage measurements and compare with last POMSEE measurements made. Follow troubleshooting procedures in Subsection 1-8, Power Supplies
b.	Inoperative converter or comparator; tubes light up but power indicator does not	Test or test-substitute the power rectifier. Measure B-plus voltage at both sides of choke and check B-plus circuit continuity. Use appropriate steps in Subsection 1-7, Power Supplies
c.	Comparator output absent or impaired when SELECTOR at COMBINED setting	Check all switch and dial settings. Monitor output when SELECTOR switched to CHANNEL A and CHANNEL B
	Either (or both) CHANNEL A or CHANNEL B inputs to comparator unsatisfactory	Retune receiver to the channel received unsatisfactorily, using input meter indications for tuning and converter monitor oscilloscope indication for BFO setting.
	Either or both channel receivers cannot be tuned for acceptable signal	Check receiver output with handset and with VTVM for amplitude. Compare with previous POMSEE readings. If receiver is malfunctioning, use steps in Subsection 1-7, Receivers

Step	Indication	Action	Step	Indication	Action
	Either converter has an unacceptable output, as indicated by the monitor oscilloscope indication or the output	Use a headset and VTVM to sample the converter input; signal trace any radio lines and switches involved if the receiver output is not present at the converter. If it is present, use the appropriate converter troubleshooting Steps d through f.			continuity through connectors to front and rear-panel TTY outputs
	Both inputs to comparator acceptable but comparator output is absent or impaired	Verify that cables and connectors involved are in good condition; then follow instructions of Steps g through j for troubleshooting the comparator	g.	Comparator does not permit associated teletypewriters to print clear copy, although either converter output will do so	Verify that both converter signals are present at the comparator SELECTOR switch. If either signal is not present, use an oscilloscope to trace it from its DIVERSITY input at the rear apron to the SELECTOR switch. The malfunction may be found to be due to poor connections at the cable-filter assembly, contacts at the SELECTOR switch, or connections at any of the intervening connectors. When both CHANNEL A and Channel B signals are obtained at the SELECTOR switch, monitor the comparator output while turning the SELECTOR to the CHANNEL A, COMBINED, and CHANNEL B positions successively
d.	Converter output absent or impaired, as indicated by monitor oscilloscope	Test all tubes or transistors in the converter discriminator subunit. Tubes having acceptable transconductance values and no internal short circuits should be returned to their original sockets. Transistors may be tested by most transistor testers without being removed. Replace defective tubes or transistors. Use an oscilloscope and a signal generator to trace the signal from the cable filter assembly input through the discriminator subunit. Switches and sealed filter units are possible causes of malfunctions		Comparator output is obtained at either CHANNEL but not at COMBINED	Inspect SELECTOR switch for dirty contacts, poor adjustment, and poor switching action. Clean, adjust, or replace as required
e.	Audio input is absent at PHONES jack of converter	Test tubes of oscillator-keyer subunit. Return good tubes to their original sockets. Use tube socket voltage and resistance measurements and, if necessary, signal tracing with an oscilloscope to localize defective components	h.	Both channel signals present at selector subunit, but comparator does not have satisfactory output	Test all tubes or transistors of selector subunit and return acceptable ones to their original sockets. Use the oscilloscope to trace the signal and determine its level, starting at SELECTOR switch
				Signal not present at keyer stage input	Make voltage and resistance measurements, at bases of selector diodes, axis-restorer diodes, and axis-restorer amplifier. Trace voltage changes through these stages with SPACE-to-MARK and MARK-to-SPACE level changes. (Reception of slow taped dots, R, and Y will facilitate evaluation of the performance of these stages.) Replace any defective components which cause incorrect values or conditions.
f.	Teletypewriter (with own loop supply) fails to print clear copy when plugged into TTY jack of converter. (Note: diversity output may be unimpaired meanwhile)	Test or test-substitute keyer, trigger, and electronic-relay tubes of oscillator-keyer subunit. If this does not correct malfunction, measure tube socket voltage and resistances to locate defective components and replace any found. If necessary, trace (using oscilloscope) the TTY signal through the subunit and check			

Step	Indication	Action
		Use an oscilloscope for further signal tracing as far as the grids of the electronic relay tubes or transistors. Make voltage and resistance measurements at the sockets in this circuitry if desired
i.	Teletype signal present at grids of comparator electronic relay tubes but not at comparator TTY output	Check all circuitry and connections between the electronic relay tube plates and the TTY output filter in the cable-filter assembly. Compare the filter's measured and specified ohmic resistance; test-substitute a new filter for the original if it is suspected to be defective. Note that plate voltage for the relay tubes is supplied by the external teletype loop. Unit operation cannot be tested in use unless the positive side of the loop supply is applied to terminal A of the TTY OUTPUT connector. The negative side of the supply will then be to the converter-comparator ground through the teletype equipment plugged into the local loop
j.	Keyed audio signal not present at PHONES and TONE OUTPUT jacks	Test the oscillator-amplifier, phase-splitter, and tone-modulator tubes; return acceptable tubes to their original sockets. Replace defective tubes. Use an oscilloscope with sweep set to a submultiple of the AF for troubleshooting audio section malfunctions. Apply the probe to successive grids in an order progression following the first oscillator-amplifier plate. Check and correct the reason for any unexpected signal loss. Test connector continuity and winding continuity of the TONE OUTPUT transformer in the cable filter assembly.

c. FACSIMILE TRANSCIVER TROUBLESHOOTING.

Facsimile equipment in use by the Navy consists mostly of Facsimile Transceiver TT-41B/TXC-1B, associated Rectifier Power Unit PP-86D/TXC-1 and terminal equipment, and some related models of each. This transceiver with its power supply is capable of nonsimultaneous transmission and reception of graphic material. In reception, the copy is reproduced either directly (by a stylus on Teledeltos or reproducing paper) or photographically (positive or negative).

No troubleshooting is needed for short-haul wire transmission of the amplitude-modulated 1800-Hz facsimile output signal. Conventional AM communication equipment can be used for its transmission by A4 emissions, but this method is subject to deterioration of reproduction with signal fading. Conventional teletype transmission terminal equipment, with the addition of Keyer Adapter KY-44()/FX and Frequency Shift Converter CV-172/U, permits frequency-shift transmission (F4) of facsimile signals. Subcarrier frequency-shift (SCFS, A4 emission) transmission requires the use of Modulator, Radio MD-168/UX before the phone modulator of an A3 transmitter. The receiving equipment is the same as for F4 transmission, except that the BFO is not used and hence imposes no stability problem.

No troubleshooting data on the terminal equipment associated with the facsimile transceiver is given, because of the variety and few applications of such equipment. The following troubleshooting procedure is for Facsimile Transceiver TT-41B/TXB-1B; the steps given are for identifying specific malfunctions, the corrective measures are obvious in most cases. More detailed maintenance information is available in technical manual for Facsimile Transceiver TT-41B/TXC-1B. Additional maintenance information can be found in the Maintenance Standards Books, or Maintenance Requirements Cards.

Step	Indication	Action
a.	Equipment entirely inoperative	Check switch settings. Verify that power plug and cord are in good condition. Inspect main power fuses (5amp.)
b.	Motor fails to turn, but indicator lamps light when equipment is switched on	Inspect motor fuse. Test motor output amplifier tubes V5 and V6. Inspect and test motor for binding bearings, loose bearings, or rotor striking field laminations. Inspect mechanism for binding. Test motor windings for open circuits. Measure B-plus voltage. Verify that phase magnet and switch (used in starting motor) are operating correctly
c.	Motor fails to sync and copy is skewed	Verify that regulated B-plus has the correct value. Test-operate the equipment with the receiver

Step	Indication	Action	Step	Indication	Action
		set to WWV transmissions if WWV has been selected as the standard. Otherwise, set to the transmission selected as the frequency standard. Follow the instructions given for determining and adjusting motor speed in the technical manual for Facsimile Transceiver TT-41B/TXC-1B			input to where it is lost, using a VTVM for indication if only the presence or amplitude of the signal is to be determined. Possible causes are low input and poor condition
d.	Exciter lamp not lit, low or flickering	Check lamp continuity (if out entirely). Inspect the lamp socket for defects. Check interchassis Jones-plug connections. Determine if power unit is operating correctly. Test tubes V17, V20, and T15 in particular	i.	Recorded material is uniformly skewed	Measure fork oscillator frequency. Perform Step c
e.	No signal output, but indicator lamps and motor operate normally	Check condition of exciter lamp and phototube by testing or substitution. Test RECORD switch for continuity and sample the signal at that point. If the previous steps are ineffective, test all transceiver tubes, returning the satisfactory ones to their original sockets	j.	Recorded material has line content (may be wavy)	Remove receiver antenna and shunt terminal with 300-ohm resistor. Local system pickup is responsible if lines are still present. Verify that shielded cable is used for all connecting links and that all are in good condition. Shunt grids or terminals with a 0.01- μ F capacitor in systematic progression until line signal disappears from head-set or oscilloscope used for monitoring. Determine condition of components in area those identified as possible causes of the malfunction; use tube socket voltage and resistance measurements if necessary.
f.	Low signal output in TRANSMIT position	Perform all preceding steps. Test for impedance mismatch by removing load and measuring signal on AC scale of VTVM. Signal should be reduced to about half when load of proper impedance is connected	k.	Random dark and light streaks in recorded copy	Check regulated power supply output. Check condition of recording lamp if photorecording. Determine condition of lead screws
g.	Low contrast in transmission and reproduction material	Check exciter lamp and socket for condition. Clean optical system. Test-substitute a new phototube to determine condition of old one	l.	Recorded copy characterized by tone reversal and fuzziness	Adjust contrast. Verify that both transmitted and recorded copies are wrapped tightly around drums. Check optical systems of transmitting and recording equipments for cleanliness and focus; clean and focus if necessary
h.	Low-level RECORD indication	Verify that input signal is at a satisfactory level. Perform preceding Step e. Compare material recorded by the direct "stylus" method with that photorecorded. If both are defective, the malfunction lies in circuitry used for both functions. In this case, trace the signal (a fixed-level, fixed-frequency FM input) from the	m.	Defective contrast in recorded copy	Verify that contrast is set correctly. Verify that neither paper nor developer is from expired, outdated stock. Verify that the developer is not too cold
			n.	Recorded copy too light	Repeat preceding Step m. In addition, verify that the recording lamp and

Step	Indication	Action
		socket are in good condition if photorecording is used.

d. TELETYPE PANEL.

Teletype equipment is usually connected to a transfer and metering panel, rather than directly to its associated terminal equipment. This permits the greatest possible versatility in equipment usage and also facilitates substitution in the event of equipment failure.

Teletype Panel TT-23/SG is commonly used in small and shipboard installations to provide for patching up to 12 teletype and test equipments to as many as 6 terminal equipments. It also permits control and metering of the current in each of the six loops. This equipment is relatively troublefree, but an outline of troubleshooting procedures is given following in the event difficulty is encountered. Although intended for Teletype Panel TT-23/SG, it is applicable to others as well.

Step	Indication	Action
a.	No LOC. CUR. - powered loops operate or have current indication.	Use voltmeter to determine if loop power is present at the panel at all.
	No loop power present at panel.	Check output of and connections to the associated power supply; follow the procedures given in Subsection 1-7, Power Supplies, if power is absent.
	Loop power present	Test continuity of panel power wiring from power input to terminals of LOC. CUR./EXT. CUR. switches
b.	Loop power present but all loops are inoperative and indicate an incorrect current or no current	Open panel and inspect all connections and the condition and operation of the loop selector switch. Repair any defective or questionable connections found and clean, adjust, or replace the switch if necessary
c.	Loop power present, but meter indication incorrect or absent for all loops, whether or not operative; Step b has been performed	Measure the resistance of the meter calibration resistor and replace it if incorrect (900 ohms $\pm 1\%$ for Teletype Panel TT-23/SG)
d.	Loop power present and loops operating, but no current indicated for any loop	Adjust LINE CURRENT control for correct voltage (0.6VDC for 60-ma loops) across the 10-ohm meter shunt resistor of

Step	Indication	Action
		a LOC. CUR. loop selector switch. Measure the voltage across the meter calibration resistor. Now measure the voltage across the meter
	Full voltage measured across meter, none across calibration resistor.	Meter is open; replace it
	Full voltage measured across calibration resistor, none across meter	Check meter to find if it is short-circuited; if so replace it
e.	One loop inoperative when switched to LOC. CUR. supply (checked with all plugs removed from loop)	Perform preceding Step b for malfunctioning loop. Determine condition of current-limiting resistor (R104) for malfunctioning loop. Determine condition of meter shunt resistor (R102) for malfunctioning loop
f.	One loop fails to operate or give indication of current flow.	Remove all plugs from loop jacks. If loop is still inoperative, check continuity through terminal and teletype equipment wired into loop
	Loop is operative with all plugs removed.	Plug one equipment at a time into looping jacks of malfunctioning loop until operation fails and no current is indicated. Identify plug which stops when inserted.
	Open-circuited equipment or plug identified.	Verify that equipment or plug is defective by substituting it for a similar, operative equipment.
	Open-circuited condition identified and verified.	Inspect condition of plug, leads, and connections; repair or replace any found defective. Test teletype equipment for open circuit and correct it if found.
	Suspected equipment and plug operate when inserted in another loop	Inspect malfunctioning jack for poor connections, dirty or pitted contact surfaces, and incorrect mechanical action

Step	Indication	Action
	One loop fails to operate or give indication of current flow when a plug (dummy or connected to equipment) is inserted in loop SET jack	Inspect condition and operation of SET jack. Clean contact surface, resolder poor connection, and adjust spring members as required for correct operation. Leads from loop should be disconnected from wired-in teletype equipment (3-series and 4-series terminals) and shorted when plug is inserted in SET jack. Inserted plug should then make connection with the teletype equipment wired to the 3-series and 4-series pair of terminals

1-11 ANTENNAS AND ANTENNA SYSTEMS

For radio communication, the antenna is the key element in the system. A transmitter may have high power output, but it is the antenna that must radiate the power. A receiver may have high sensitivity, but it must sense the minute currents in the antenna. If the antenna is lossy, communications cannot help but suffer. For example, an antenna that is short with respect to wavelength may exhibit a radiation resistance (the virtual resistance into which an antenna is presumed to deliver its radiated energy) as low as 15 ohms. If the loss resistance is also 15 ohms, then half the power in the antenna system is dissipated in lossy elements.

The deceptively simple appearance of antennas tuners, couplers, and antenna patch systems may lead to neglect of maintenance. True, there are no tubes or transistors or power supplies in an antenna. But try to think of the antenna, its tuner, and its ground return path as a high-Q circuit in which RF currents circulate.

Shipboard antennas operate in a hostile environment replete with salt water and stack gasses containing acids, sulfur, and soot. If nothing else, antennas need environmental protection.

a. WHAT DOES ANTENNA CURRENT MEAN?

"Meter inoperative, evidently burnt out. 0-5 ampere range seems too low. We find it difficult to keep antenna current this low on most frequencies USS ____." This report is made frequently. Here is another typical report. "...by changing the length of the antenna, the current was raised from 1 ampere to 2 amperes, thereby increasing our field strength..." This statement is incorrect. The operator merely moved the standing wave relative to the ammeter to bring a high-current part of the standing wave onto the ammeter. The field strength did not necessarily change, and the operator had to record new adjustment settings for his loading circuit due to the altered input impedance of the antenna. It is believed that the following short discussion will prove helpful to the understanding of the distribution of current in an antenna system.

Figure 1-27 shows an antenna system with the parts drawn stretched out in a line. Figure 1-28 shows a standing wave of current of an antenna system. The shape of the loops is supposed to be sinusoidal, but these curves will suffice for discussion purposes. Length in the horizontal direction means "distance along a wire." Height in the vertical direction means "quantity of current in the wire." The curves show the amount of current at any point in the wire. The current in a standing wave is not the same all along the wire, but varies as shown in Figure 1-28. There are several ways to draw a standing wave, but the one shown is one of the best because it shows all current as positive, or above the zero line, which is the only way a thermocouple-ammeter can indicate it. In practice, the standing wave is not as smooth as shown, but is partly irregular due to changes in surge impedance along the length of the antenna system.

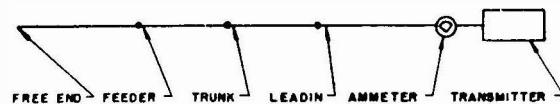

Figure 1-27. An Antenna System

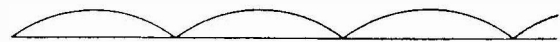

Figure 1-28. A Standing Wave of Current

Consider a standing wave for a frequency of two megacycles. Its half-wavelength is computed by dividing the frequency in megacycles into 492 feet. The answer in this example is 246 feet which means that there will be 246 feet between the nulls or zero-points of the standing wave (see Figure 1-29). This distance between nulls is called a half-wavelength. Notice that all points separated by a half-wavelength have the same amount of current in them.

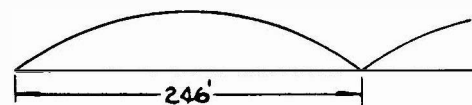

Figure 1-29. A Half-Wave at Two Megahertz

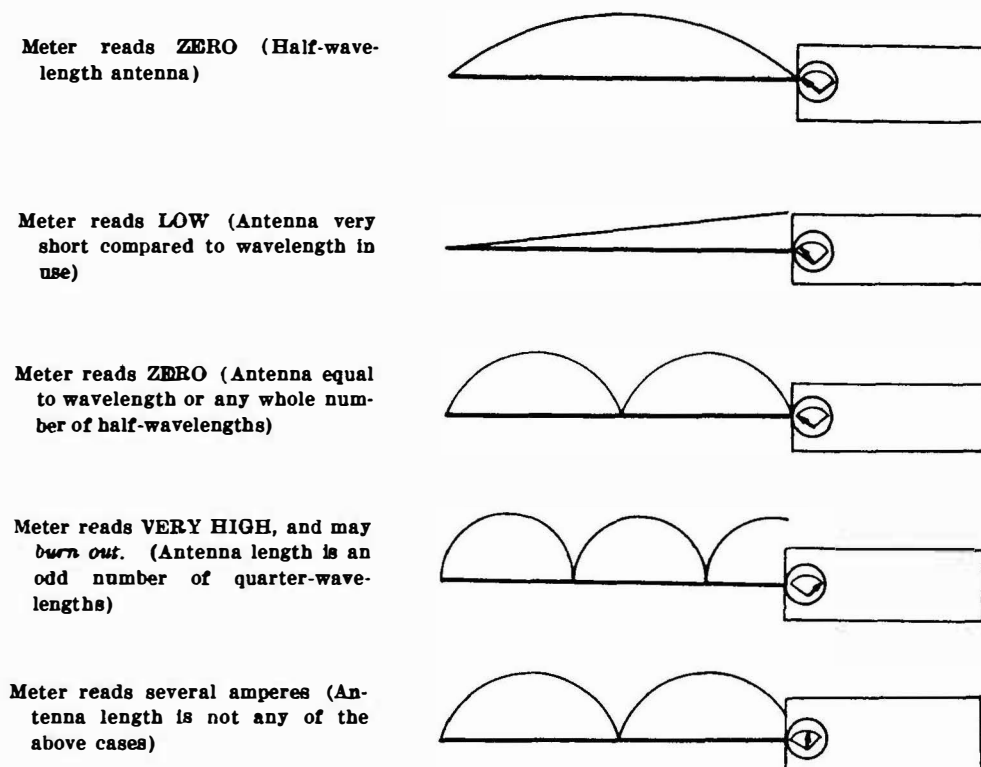

Figure 1-30. Ammeter Readings for Various Combinations of Antennas and Frequencies

Figure 1-30 shows how much current the ammeter will indicate for various combinations of antenna length and standing wave. The antenna's length is fixed aboard ship, but the standing wave's length varies with the frequency as described above. Each example has a note beside it giving an estimate of the current. The antennas are drawn spread out like the one in Figure 1-27. Actually each antenna can be of any length, and each standing wave can be of any frequency, provided the standing wave and antenna fit each other as shown in Figure 1-30.

The conditions shown in Figure 1-30 will occur when the ammeter is connected between the antenna and the loading reactors of the transmitter—which is usually the connection used. In a very few cases, the transmitter utilizes a different connection, with the ammeter in the loading circuit, and then the readings depend on the tuning as well as the antenna lengths.

The most useful services that the ammeter can perform are:

1. On frequencies for which the antenna current happens to be large enough at the location of the ammeter to indicate some current, one can be sure that modulation is occurring by watching the ammeter move during speech or mcw transmissions. The meter usually moves slowly and reads only 22.5 percent extra current during 100 percent modulation. (A superior modulation indicator would be a monitor

built for the purpose, with which an oscilloscope or headphone indication is used.)

2. If the ammeter indicates a readable current, then it can be used as a carrier indicator because the current reading will drop if the carrier fails. However, this function is not important as the final plate ammeter and other meters will indicate the same thing. Another excellent carrier indicator consists of a neon bulb loosely coupled to the antenna. This also makes a satisfactory modulation checker.

3. If the ammeter current is readable and if the antenna (or dummy antenna) input resistance is known, then the power output of the antenna may be computed. In general, the technician does not know the antenna resistance.

4. If the ammeter current is readable it can be used as a guide for further tuning of any stage in the transmitter. However, the transmitter is usually equipped with other meters for tuning the transmitter correctly.

5. The antenna ammeter is useful for the indication of accidental changes in the transmitter output or in the antenna impedance (due to grounds, etc.) provided that the correct reading for the frequency in use is recorded and checked frequently. This action is also equally well accomplished by observing the final plate ammeter.

6. The antenna ammeter is often useful when reducing the output power, since reducing the antenna current to half its normal value will reduce the radiated power to one quarter its normal value.

It should now be evident that the antenna current meter is useful, but not a necessity, and that in a given installation it can indicate any current from zero to off-scale, the value depending on the frequency as well as on the amount of power fed to the antenna.

What to do when the frequency in use is such that the antenna ammeter indicates zero: NOTHING!! Proper use of the final plate ammeter will indicate that power is being fed to the antenna.

What to do when the antenna ammeter is being driven off scale: Try to take action, because the meter may burn out and prevent transmissions until a repair is effected. You may reduce the transmitter power by decreasing the power fed to the transmitter.

b RECEIVING ANTENNAS ABOARD SHIP

The best receiver on board cannot contribute to effective communication if its antenna is ineffective. Antennas operate better at some frequencies and in some directions than others, depending upon its length and its position relative to adjacent metal bulkheads, masts, rigging, and weapons. An antenna may operate fine while the ship is on one course, but its effectiveness may drop to practically nothing when the ship changes course. A proficient operator will check constantly to see if he is getting the best reception by changing antennas when the CARRIER LEVEL or the INPUT meter has decreased from its normal position.

One thing that can be done to properly maintain the antenna system is to keep the antennas and accessories clean and the connections tight. Shipboard antennas, due to ordnance and other considerations, are not the best antennas for reception, but we can do our utmost to keep what we have in good operable condition. Following are a few suggestions for RM and ET rates to keep the antenna system in tip-top condition:

1. Consider the antenna system as consisting of everything from the outboard or top insulator to the antenna input of the receiver. This includes all insulators, junction boxes, static drain resistors, coaxial cables, all connections, patch cords to individual receivers, and the antenna jack on the receiver. From the radio wave point of view, all this is only one-half the antenna; the other half is the ground plane and ground return path.

2. Insulator cleaning and maintenance is a must. The time between cleaning the lower insulators is dependent upon the type of ship, the tempo of operations, and the area of operation.

3. Junction boxes may hold a resistor used to drain static electricity from the antenna. The boxes should be opened and inspected at least every six months. The resistor should be measured and inspected to ascertain if it is the proper size and in good condition. Connections within the box should be critically inspected to make sure they are in good shape and well protected. The gasket on the box should be inspected and replaced if necessary, then the box well sealed and all bolts or screws installed and tightened down to prevent water or salt spray from entering the junction box.

4. While the junction box is open and the static drain resistor is out of the circuit, the coaxial line from the antenna patch panel should be checked for grounds and continuity from the radio central end of the cable. A reading in the high megohm range will show if the antenna and the center conductor of the coaxial cable are free from ground, but does not prove that junction boxes, connectors, and cables have continuity through them. Next ground the antenna near its base and check with an ohmmeter for continuity to ground from the center conductor of that particular antenna outlet on the receiver antenna patch panel in radio central, or wherever the antenna appears inside the ship. The reading should not be more than 1 or 2 ohms. Then remove the short, and again megger for short to ground. If a high reading is not obtained it is possible that the coaxial cable will have to be replaced.

5. Filter board receiver antenna patch panels should be tested in accordance with the instruction book for proper operation of the filters. On a more frequent basis the isolation resistors for the antenna outputs should be checked with an ohmmeter. It is common for these resistors to be completely burned out because of induced RF currents from nearby transmitting antennas. Remember that R-390 receivers place a short across their antenna input when the receiver is placed either in standby or calibrated mode; this short will affect all other receivers on an SRA-12 type receiver antenna patch panel.

6. Disconnect the antenna plug from the receiver and check the coaxial line from the receiver antenna patch panel to determine that the coaxial cable has high resistance between inner and outer conductors. Check for continuity by shorting one end of the coax and checking with an ohmmeter for a very low resistance less than 1 ohm. Inspect the antenna jack on the receiver for tightness and then reconnect the antenna into the receiver.

Granted that this is a lot of work, but it will eliminate hours of fighting to receive some frequencies that should be loud and clear. Normally junction boxes, coaxial cables, and hardware need inspection only once every six months. Insulators should be cleaned once a week or even more often.

The same procedure applies to transmitting antennas when checking the insulators and hardware. On high frequency type antennas, insulator cleaning and maintenance is quite simple. A complete check on UHF antennas requires that watertight connections high on the mast be opened, a procedure more likely to be harmful than beneficial. Such checks should be made only during major overhaul, and thereafter relying on VSWR readings taken on three frequencies in the range of the equipment tied to a particular antenna. The three frequencies should be as close as possible to the top frequency, the middle frequency, and the lowest frequency. If degradation of VSWR indicates antenna trouble, then it may be necessary to open the antenna connections for troubleshooting purposes.

When transmitting antennas are being meggered, remember that dry salt is an insulator, and the salt deposit will not become conductive until it becomes damp. For this reason the antenna should be meggered early in the morning while the morning dew is still present.

During operations at sea, the salt deposit on insulators continues to build up, and it is not always possible to close down transmitters long enough to effectively clean insulators. Advantage can be taken of the principle that the salt deposit becomes more conductive as its thickness increases. The second principle is that sea water is a relatively poor conductor, especially when it is in a thin film. Based on these principles, an alternative procedure of shutting down transmitters and using a fire hose as a salt water washdown can be effectively used to reduce the salt deposits on antennas and insulators.

The preceding preventive maintenance procedures are included in the shipboard Planned Maintenance System (PMS). Continued performance of PMS will measurably reduce the problems stated in this article. (EIB 723, 738)

c. WHIP ANTENNA MAINTENANCE

Whip antennas, particularly the NT-66053, NT-66046 and NT-66047, are the most overlooked items of shipboard communication system maintenance. With the exception of cleaning insulators and correcting obvious faults (i. e., antenna breaking off), antenna maintenance is often completely ignored. Because of the frequency of problems relating to faulty antennas, it is a practice of MOTU units to check whip antennas when answering calls for assistance on antenna tuners, couplers, RFI, or antenna loading problems. Many tuner and RFI problems have been corrected by cleaning or repairing the antenna.

The General Maintenance EIMB (NAVSHIPS 0967-000-0160), Shipboard Antenna Details (NAVSHIPS 0967-117-3020) and PMS cards specify quarterly and monthly checks on all antenna systems. It is quite obvious that scheduled maintenance is not the practice on the majority of ships that have requested MOTU assistance. The principal problems encountered with whip antennas are:

1. Dirty insulators
2. Moisture and corrosion problems
3. Defective or missing grounds on antenna tuners and safety cages.
4. Bad RF connections between the tuner and the antenna, and between antenna sections.

Checking the antenna with a megger will show up dirty insulators and moisture problems, but will give no indication of bad RF connections. It appears that as soon as a gap forms between any mechanical connection, oxidation and sulfation of the metal surface takes place. This forms a semiconductor barrier which, when antenna RF currents flow through it, is capable of causing broadband EMI. In many cases the junction is so bad that it may be measured with an AN/PSM-4 as a DC resistance. This effect is further aggravated by the action of salt water and stack gasses on aluminum antenna parts to form other corrosion products (aluminum chloride and aluminum oxide). The bottom (lower) section of the whip fitting

into the socket in the adaptor base is especially susceptible to the action of water and stack gasses if it is not protected. It is not uncommon to find installations where the large gland that tightens the connection can be turned down half an inch or more with the fingers.

In the past year MOTU-13 has found approximately 20 whip antennas that could be lifted from sockets by one man without loosening the gland nuts. Another six were found that measured 50 to 2000 ohms with an AN/PSM-4 between the lead-in from the tuner and the first section of the whip. In one case, a DC resistance of 300 ohms was located between the top of the insulator assembly and the adaptor base containing the socket for the whip. These sections are held together by four large bolts, which should be of corrosion-resistant steel (CRES) to minimize electrolysis. Still another case showed 1500 ohms from the input lead-in to the first section of the whip.

Due to inaccessibility, it is generally impossible to check any but the first section of a whip antenna without removing the whip. Vigorously shaking the whip will reveal any loose sections. If loose sections are located, it is considered sufficient justification to remove and disassemble the whip for cleaning. If there are complaints of erratic tuning, high tuner/coupler failure (many AN/SRA-22 failures are related), or varying VSWR, the whip should be disassembled and cleaned even though no faults are apparent. This approach has proved quite successful. The replacement and/or repair of ground straps at this time has also proved very beneficial.

In addition to the maintenance requirements provided in Shipboard Antenna Details, it is recommended that all whip antennas be removed, disassembled, and properly cleaned at least every six months, with replacement and/or repair of ground straps. Proper antenna maintenance with particular attention to the requirements for antenna tuner/coupler grounding, as provided in the following equipment technical manuals, will minimize failures, CASREPTS, and reports of erratic tuning:

AN/SRA-22 NAVSHIPS 0967-136-6010

AN/URS-38 NAVSHIPS 0967-204-0010

CU-937/UR NAVSHIPS 0967-971-0010

(EIB 785)

1-12 NAVIGATIONAL AIDS

a. RADIO-DIRECTION-FINDER EQUIPMENT

Radio-direction-finder equipment indicates the direction of a received wave. Special construction of its antennas permits accurate determinations of the true bearing of the received wave. This bearing is the direction of the transmitting station.

A radio-direction-finder system consists of a directional-receiving antenna, a sensitive radio receiver, and an indicating device. Often the direction-finder indicator is a cathode-ray tube

encircled by a plate etched with 0 to 360 degrees of compass markings. Direction indicated is the result of rotation of the loop antenna or loop-antenna goniometer. A characteristic directional response will appear on the face of the cathode-ray tube when the antenna or its goniometer is in position to indicate station direction. The receiver only serves to detect and to amplify the antenna response.

b. THEORY OF RADIO-DIRECTION-FINDER ANTENNAS

A fundamental law of electromagnetism is that when a conductor is cut by magnetic lines of force, a voltage is induced that is proportional to the rate that the conductor is cut. This law also applies to the electric and magnetic field components of radio waves. Electric and magnetic field components of a radio wave are inseparably related. Only the magnetic component need be considered to establish combined electrical and magnetic characteristics. This rule is true for the interaction between an incident wave and a receiving antenna. In this case, the magnetic component indicates the total interaction present between the wave and antenna.

A normal or vertically polarized wave will induce voltage only in a vertical section of a conductor. A vertically polarized radio wave has a horizontal magnetic field. A vertical wire or "monopole", the simplest form of a vertically polarized antenna, may be a part of the radio-direction-finder system. Its operation provides basic information for an understanding of direction-finder loop antennas. When a vertically polarized radio wave passes over a monopole antenna, the antenna will be cut by the horizontal lines of flux in the wave. The height of the antenna and the intensity of the alternating flux determine the induced voltage. The induced voltage is in phase with the alternating flux waves. If the flux-wave intensity is constant, a change in its azimuth direction will make no change in the values of the induced wave.

(1) The Response of a Loop Antenna

When the horizontal lines of flux of an incident wave cut the two vertical members of a loop antenna, instantaneous voltages are produced at the two vertical members. These voltages go in the same direction in Figure 1-31, the vertical members of the loop antenna are represented by lines A and B. The arrows adjacent to A and B indicate the vertical direction of the simultaneously induced voltages. While they follow their vertical path, opposing currents circulate horizontally around the loop. These currents completely neutralize one another when voltages induced at the vertical members are equal.

The magnetic field of an incident wave has lines of flux of various densities. They arrive at the two vertical members of the loop antenna in a sinusoidal pattern. Figure 1-32A illustrates this pattern. The lengths of the flux-density lines represent the relative amounts of density. The arrow heads on the flux-

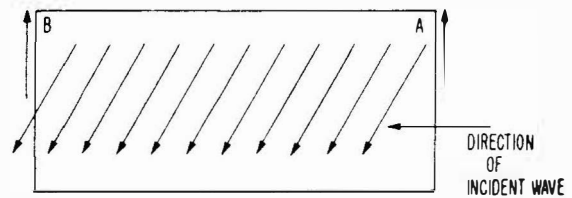

Figure 1-31. Currents Induced in a Loop Antenna

density lines indicate the direction of the lines of flux.

Figure 1-32 shows the relationship of the incident wave and the induced loop voltage. Note that the induced loop voltage differs in phase from the incident wave by 90° .

Size or location may prevent the rotation of a loop antenna. A goniometer combined with a pair of stationary loops at right angles produces the equivalent of a rotating loop.

(2) Troubleshooting

Locating faults in a radio-direction-finding set should be systematic. First determine the faulty unit. If it is the receiver, determine whether the trouble is common to all frequency bands. If it is one band only, the trouble probably is in the radio frequency or oscillator unit. (Intermediate frequency, audio frequency, and indicator circuits are in use on all bands.) The main tuning capacitor and its vacuum tube and associated circuit components, the power supply, and control circuits may all be eliminated since they are common to all bands. Trouble may be an element selected by the switching operation or the actual switching device. Therefore, the coil assemblies and waveband switch should receive attention. Resistance tests of the radio-frequency amplifier and oscillator circuits will determine which one is at fault. If, in the defective circuit, the indicated resistance value changes with a slight movement of the band switch, a faulty contact may be indicated. If the abnormal resistance value remains constant, the fault probably is in the coil assembly or wiring. Examine the switch contacts and the wiring of the stage involved. If they appear to be in good operating condition, investigate the coil assembly.

(3) A Rough Guide to Circuit Location of Faults

The amount and nature of background noise in the loudspeaker is a rough guide to the location of the fault. Absence of any sound probably would be due to power failure or to trouble in the output stage or output circuits. Normal microphonic sounds, without hiss, probably indicate a normal audio amplifier system, but a faulty radio-frequency system. Weak signals accompanied by background noise may indicate some fault in the antenna system or transmission lines.

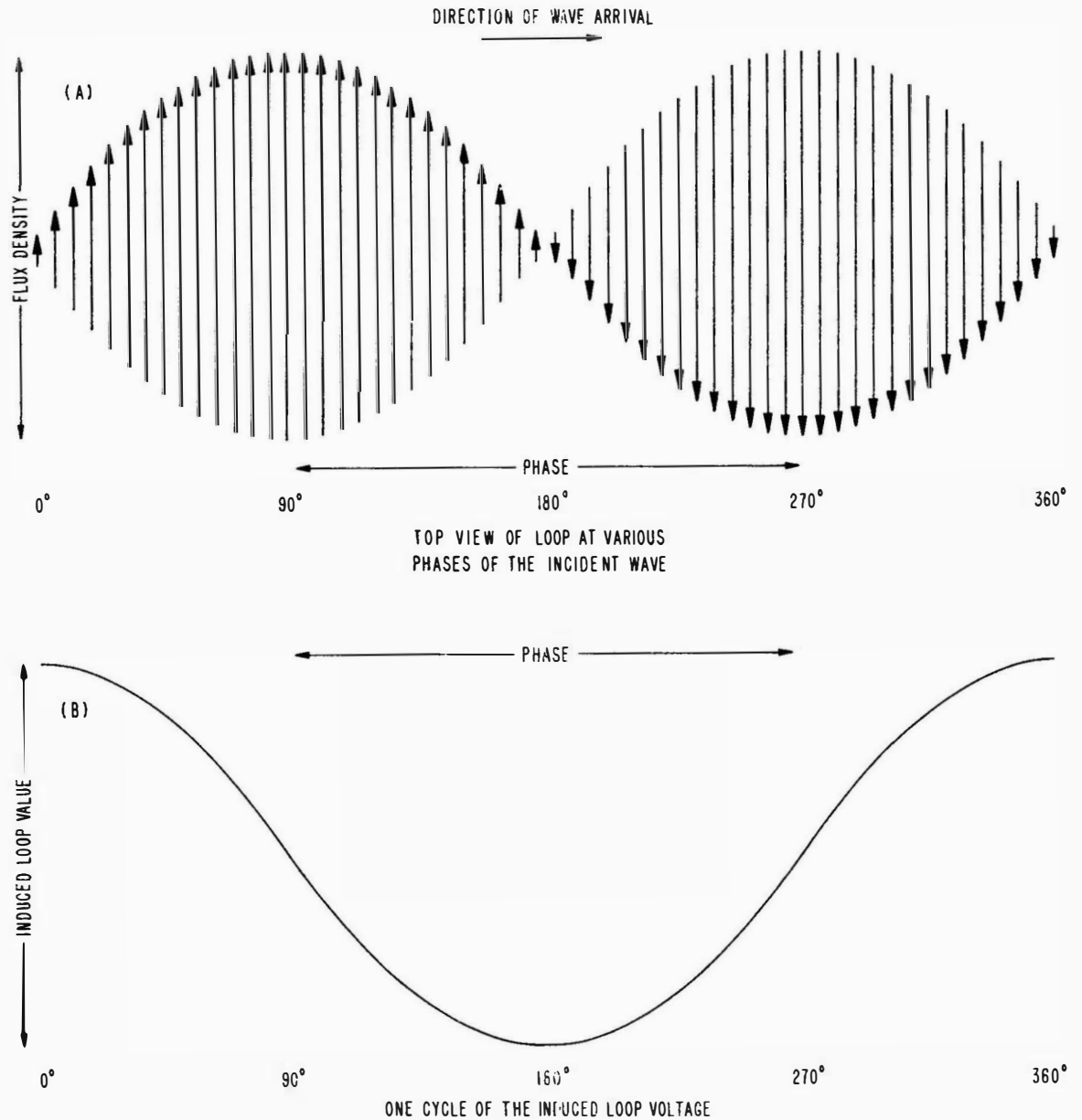

Figure 1-32. Induction of Alternating Voltage in a Loop Antenna Showing 90-Degree Phase Difference with the Incident Wave

The indicator is an excellent guide in trouble location. If automatic bearings remain fixed at 0° and 180° or 90° and 270°, regardless of the direction of arrival, trouble in one of the directional channels and its associated cables and goniometer is indicated. Where a cathode-ray screen indicator is used, magnetized-iron parts in the automatic bearing indicator will show up as offsetting points of the usually symmetric propeller pattern.

Bearing error can be caused by refraction of the received wave. Terrain and atmosphere between the transmitter and receiver cause the wave to change direction. Bearing errors are caused also by sky-wave reflection and by radiation from other antennas. Two signals near the same frequency and input level will cause the indicator to shift between them. It probably will be impossible to get an accurate reading on either of them.

Shipboard transmitter radiation may cause the indicator to hunt. Deenergizing the transmitter will eliminate interference temporarily. Then it will be necessary to move the d-f antenna or the transmitter antenna to a location where transmitter radiation does not cause unstable indications.

c. GENERAL MAINTENANCE OF RADIO-DIRECTION-FINDER EQUIPMENTS

Pilot and Dial Lamp Failure

When all pilot and dial lamps are out, the probable source of trouble is the AC power supply or the filament circuit.

If the AC supply is at fault, the probable cause is the power switch, a fuse, power input or output cables (possibly at the plug), or the filament-supply circuit.

No Signal, Weak Signal, or Incorrect Bearing Indication

These trouble indications can usually be traced to one of the following:

- Power supply failure.
- Faulty antenna connection.
- Weak or burned out vacuum tube.
- All DC voltages are low.
- Incorrect cable connection.
- Shorted trimmer or tuning capacitor.

Power Supply Failure

When the trouble is in the power supply, the probable cause is a burned out or weak rectifier tube, faulty contact to rectifier tube pin or pins, break in continuity of power-unit cable, or shorted filter or bypass capacitor.

Faulty Antenna Connection

Poor contact between input receptacles and mating plugs or adapters may break the continuity of the antenna circuit. Other things that may create bad antenna connections are grounded or open junction-box circuits, grounded or open goniometer circuits, and grounded or open interconnecting cables.

Continuity checks will indicate open or high-resistant antenna circuits. With Multimeter AN/PSM-4 or equivalent, continuity may be measured in the following manner:

1. Disconnect the transmission line at the antenna. Connect a clip lead between the disconnected conductor and ship's ground.
2. Disconnect the transmission line at the receiver and connect one lead of the multimeter to its center conductor. Connect the other lead to ship's ground.
3. With the multimeter on the R X 1 scale, measure the continuity. It should be zero ohms.
4. With the multimeter on the R X 1 scale, perform continuity checks on any remaining antenna circuitry. This will include RF switches and RF cabling through junction boxes. The readings should always be zero ohms. If any reading shows an open circuit or is above zero, make a visual inspection of the faulty component for corroded or damaged switch contacts, insecure or damaged connectors, etc.

The following insulation test should be performed on the antenna transmission line:

1. Disconnect the clip lead at the antenna end of the transmission line. Using Test Set AN/PSM-2 or equivalent insulation test meter, connect one of its leads to the center conductor of the trans-

mission line and the other to its connector shell. Measure the insulation. (It should be at least 100 megohms.)

2. Perform an insulation test on any remaining antenna cabling by measuring between the cable conductor and ground. When a reading of 100 megohms or greater is not present, check for strands of shielding between the conductor and connector shell and damaged cable insulation.

When a shorted or open circuit in the goniometer is suspected, make an ohmmeter check of its circuitry. Refer to its circuit diagram to do this. With the multimeter, determine that the stators and rotors are not shorted together or shorted to ground. A stator continuity check will require disconnecting the loop and stator at one end of the stator. The ohmmeter leads will then be connected to the two disconnected wires. Resistance should be negligible, possibly four or five ohms (the total resistance of the stator winding and loop).

All Low DC Voltage

When all DC voltages are low, a weak rectifier tube, an open filter capacitor, or a low resistance to ground in the B+ circuit is the probable cause.

Shorted Trimmer or Tuning Capacitor

Occasionally a drop of solder will fall on a trimmer capacitor and cause a short between plates. Solder is pried loose gently with a small screwdriver or other small implement.

CAUTION

Take care not to scar or bend the plates in the process. Bent capacitor plates cause *short circuiting*. Straighten a bent plate with a thin, flat implement. Press against the bent plate only. Do not wedge anything between two plates.

When the plate is straightened, rotate the capacitor control. During a complete rotation, equal spacing between plates should exist.

Noisy or Intermittent Reception

Noisy or intermittent reception may be caused by the following:

- Noise pickup in the antenna system.
- Faulty cable connections.
- Defective control.
- Defective switch.
- Poor contact between a vacuum tube and its socket.
- Defective vacuum tube.
- Frayed or broken wiring.
- Poor contact between pilot or dial lamp and socket.
- Defective bypass coupling capacitor.
- Loosely mounted shielding can.

Tracing a Noise Source

Gently shake unit components while the unit is energized. Moving the loose ground lead, poor tube and socket connection, or loose shielding can will change the noise level.

When you find one loose connection, look for others. Check all chassis connections for tightness. Press all vacuum tubes tightly in their sockets.

Change control settings. If this increases operating noise levels, look for dirty electrical contacts in

the control circuits. Clean the dirty switch, relay, or other control contact with cleaning solvent Type 140F.

Tighten all cable connections. If this does not eliminate noise, look for changes in noise level when cables are shaken. Replace broken cables and clean all dirty cable connectors with dry cleaning solvent Type 140F.

If a noisy antenna circuit is suspected, short circuit or disconnect the antenna at its input to the receiver. If the noise stops, the antenna circuit is the source. Antenna circuit tests are given under the preceding topic "No Signal, Weak Signal, or Incorrect Bearing Indication".

An oscilloscope will speed discovery of a noisy coupling or bypass capacitor. With the antenna disconnected, troubleshoot the receiver from the output toward the input. Observe the waveform at each stage output. (Use a schematic and layout drawing.) Trace to the stage with a "clean" signal: where the noise distortion does not appear on the trace. The bad capacitor is in the stage previously checked or between the two stages. Replace the coupling capacitors. If the noise is still there, replace the bypass capacitors of the last noisy stage.

Fading

Fading is not always caused by circuit failure. It sometimes results from a magnetic storm. When a storm is not the cause, look for the following:

Defective coupling or bypass capacitors.
Vacuum tubes with intermittent heater operation.

Low sensitivity.

Procedure for determining defective coupling or bypass capacitors was given under the preceding topic "Noisy or Intermittent Reception".

Testing does not always detect a vacuum tube filament that opens intermittently. Interchanging tubes may be necessary.

The "Receiver Sensitivity Tests For Other Than Loran Navigational Equipments" section describes sensitivity measurements.

Indicator Pattern Satisfactory on Direction Position, but no Pattern on Sense Position (or Vice Versa).

An open deflection or sense coil will cause this. The open coil can be determined by a continuity test. A faulty brush will cause it also.

Receiver Tunes Signal Satisfactory and Circle on Bearing Indicator is Satisfactory, but No Bearings can be Obtained.

The probable cause of this source of trouble is either an open input cable or no receiver-indicator channel output. To repair the latter, check the voltage output of the receiver indicator channel, and be sure that it is the same as specified in the instruction manual for the particular equipment. If there is no voltage at the output, check circuits against the applicable schematic diagrams.

With an ohmmeter, test the continuity of the input cables. Replace or repair the cables if necessary.

Sawtooth Pattern on Cathode-Ray Tube Circular Pattern

The probable cause of this sawtooth pattern is poor contact between slip rings and brushes. Cleaning and polishing of the slip rings, adjusting brush

tension, or tightening the slip-ring retainer will remove the sawtooth pattern (Figure 1-33).

d. SCHEDULED INSPECTIONS OF RADIO-DIRECTION-FINDER EQUIPMENTS

Inspections that follow pertain to all navigational aid direction finders. They are not iron-bound rules; POMSEE and Test Methods and Practices are the guides for scheduled measurements. These are general procedures for scheduled inspections that can be performed to any DF equipment. More details and more tests are necessary for specific equipments.

Monthly Inspections

Specific monthly inspections which can be performed on all radio-direction-finder equipments are as follows:

1. Antennas. The antennas should be inspected while in yards (or equivalent conditions of safety) for the following:

Insulators: Inspect insulators for cracks, breaks, and tightness.

Elements: Check elements for alinement, vibration, and cracks in joints.

Pedestals: Check pedestals for vibration, loose mounting bolts, and poor electrical and mechanical connections. Check the condition of the pedestal cables.

Frame: Inspect its alinement and check for vibration.

Paint: Inspect for rust spots, cracks, or peeling.

2. General. Inspect all rubber used for shock mounting, replacing where necessary because of cracking or loss of resilience.

3. Receiver. Measure the receiver sensitivity in accordance with current instructions. (Refer to "Receiver Sensitivity Tests for Navigational Equipments" of this subsection)

WARNING

Receiver alinement should not be attempted except by experienced maintenance personnel with a suitable calibrated signal generator and vacuum-tube voltmeter.

4. Direction-Finder Calibration. Check the radio-direction-finder calibration curves on at least 5 points and at least 3 frequencies. Tune in transmitting stations on bearings which can be determined accurately by visual or navigational means. Vary check points and frequencies as may be practical in subsequent monthly checks.

5. Insulation Test. With an insulation test set, test the insulation to ground from all antennas and the insulation to ground from the control and power-supply circuits. Observe that the megger reading is 100 megohms or more. Major repairs, electrical alinements, and most replacements of circuit components should not be attempted at sea, but rather at a yard equipped with laboratory equipment. A tube substitution method of replacing a suspected faulty tube with a new one known to be in good operating condition will often locate and correct the trouble. In the event that this method does not work, trouble must be located methodically through elimination processes and analyses of circuit voltages and resistances.

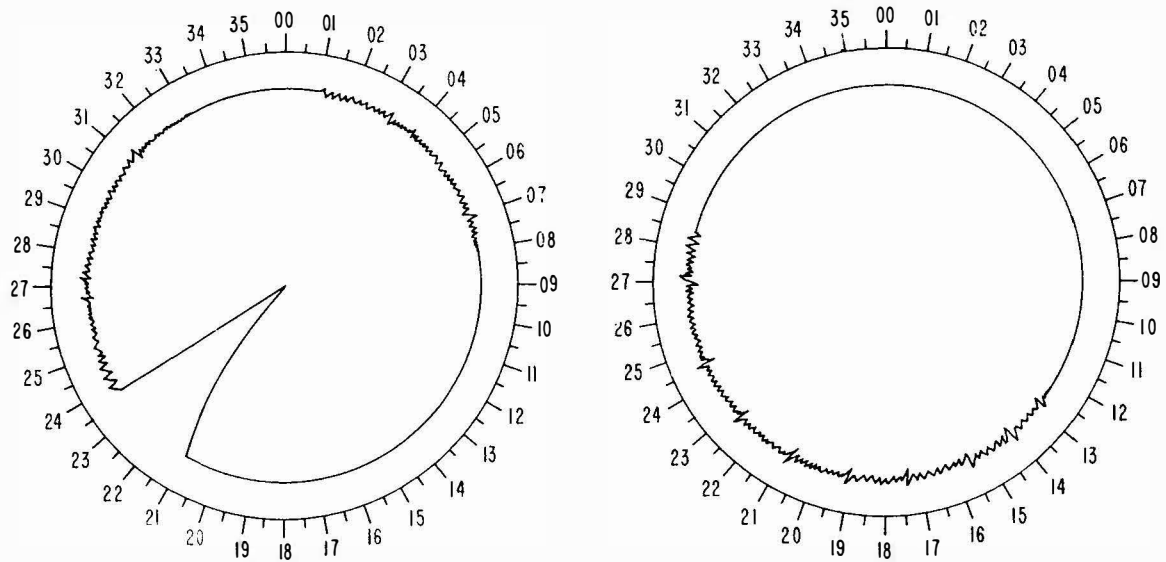

Figure 1-33. Typical Indicator Patterns Due to Poor Brush and Slip-Ring Contact.

6. Slip Rings and Brushes. Check slip rings for concentricity and looseness. Check brush pressure. Check brush pigtailed for fatigue, flexibility, corrosion, and contact. See Figure 1-34.

Quarterly Inspections

1. Antenna. Clean antenna entrance, strain, and pedestal insulators, and tighten connections. Inspect, clean, and tighten, as necessary, all accessible ground connections. Antenna insulators should be cleaned more often than quarterly when dirt deposits accumulate rapidly.

2. Receiver. (a) Make sensitivity measurements of the receiver in accordance with current POMSEE or Test Methods and Practices, and record results in log, prior to and after any corrective action, (b) Check the frequency calibration of the receiver. The calibration should be checked in the manner prescribed by the particular instruction manual or POMSEE that is assigned to the equipment, and (c) Check the operation of the receiver r-f gain, audio gain, and sense-gain controls. The controls do not require any adjustment or trimming. Controlling toggle switches, potentiometers, and vacuum tubes are the usual causes of lack of or absence of gain. Frequent troublemakers are those toggle switches which are operated so seldom that the small amount of oxide that forms on their contacts renders them inoperative. Periodic operation for ten to twenty minutes will usually permit these switches to remain in good condition. Potentiometers, however, usually become faulty from excessive use. When this occurs, the faulty potentiometer must be replaced.

(1) Transmitter Power Measurements

Because of radiation, transmitter tuning presents problems, some of which may be eliminated by tuning while the ship is at its base. Accurate logging of dial setting during pretuning can eliminate

much of the tuning at sea and speed all tuning. Frequency-dial settings based on interpolations are permitted in pretuning where exact frequencies are not required. Oscillator frequencies, which are not crystal controlled, are set by means of frequency meters.

Audio Frequency

For testing operations which require the repeated measurement of audio-frequency power, commercial power meters are available. These instruments are generally composed of a ratio transformer, a constant-resistance multiplier, and a voltmeter. The ratio transformer is compensated by various resistances which allow the effective load imposed on the output stage to be varied over a number of steps. The constant-resistance multiplier acts as a range multiplier for the voltmeter while presenting a constant resistance to the secondary of the transformer. Indications are calibrated in watts with this type of instrument.

When phase angles are introduced by reactive components, power measurement by the previous method is no longer applicable and wattmeters, which are proportional to the power factor as well as the apparent power, must be used. Even wattmeters are not practical at high frequencies. Stray capacitances and inductances, skin effects, and other complications increase as frequency rises.

Power Meters

When close accuracy is not essential compact test equipments called RF power meters are used to furnish direct readings of RF power. A power meter is small and portable, even when designed to measure outputs as great as 500 watts. Power meters are suitable for direct measurements from 3 MHz to 300 MHz.

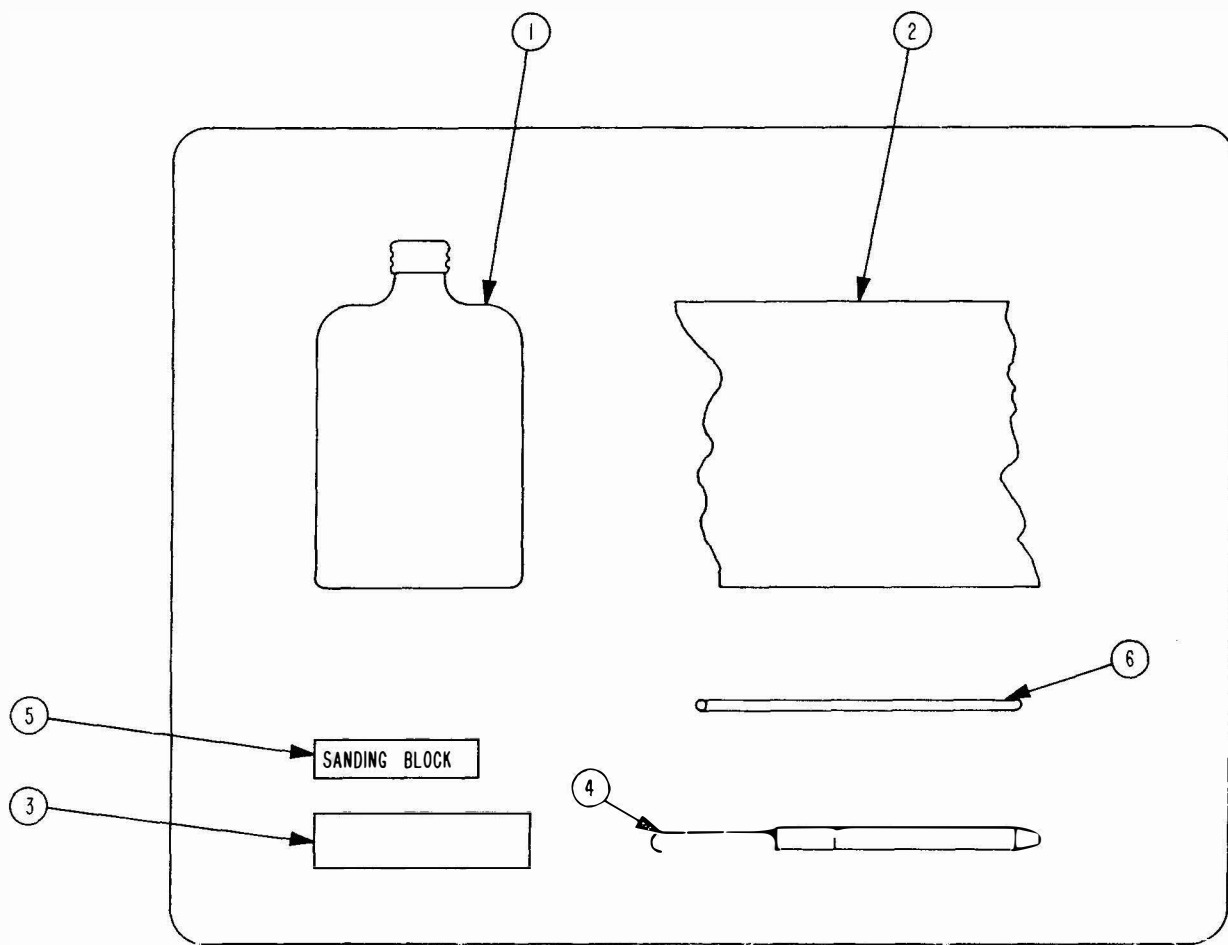

1. CLEANING SOLVENT TYPE 140F.
2. 5 YARDS OF CHEESE CLOTH.
3. 6 SHEETS ARMOUR SANDPAPER WORKS CROCUS CLOTH OR EQUIVALENT.
4. 1 SPRING-TENSION GAUGE GRADUATED IN 1/2 OUNCES.
5. 1 BLOCK BAKELITE OR OTHER SMOOTH-SURFACED SUBSTANCE 2" X 3/4" X 1/8".
6. 3/8" X 5" BAKELITE ROD (OR NON-METALLIC ROD).

Figure 1-34. The Necessary Equipment for Servicing Slip Rings and Brushes.

Radio-Beacon Transmitters

Navigational-aid transmitters are restricted to radio-beacon equipments and are relatively simple. A complete transmitter may include as little as a radio-frequency oscillator, a pulse modulator, a keyer, and a power supply.

Receiver Coupler Tuning in Radio-Beacon Transmitters

WARNING

High voltage, dangerous to life, is present in transmitters. Before making any internal adjustments, set the high and low voltage switches to OFF.

Tune the receiver-coupler coil until the shore-station signal is of maximum amplitude, making sure that the signal on the scope is below saturation. While making this adjustment, note the antenna current. The antenna current will be somewhat reduced when the receiver coupler is far off tune. It may be necessary to slightly retune the transmitter after tuning the receiver coupler.

When the transmitter includes coil taps, set them according to the equipment instruction manuals. Other transmitter adjustments, which are peculiar to the individual equipment being tested, will have to

be performed according to the appropriate equipment instruction manual.

(2) Receiver Sensitivity Tests for Navigational Equipments

Preparatory Steps

1. Check the power supply and line-input voltages.

2. Place a 600-ohm noninductive resistor across the output of the receiver unless another load value is specified by the instruction book for the equipment. The resistor must have a high enough wattage value to handle the maximum receiver audio output. High impedance headphones must be used if it becomes necessary to connect headsets in parallel with the output resistor.

3. Place the leads of an audio voltmeter across the output terminals of the receiver. This meter must be capable of accurate indications from 0.1 volt to 100 volts with negligible loading of the circuit. Although some receivers have audio-output meters, such meters may not indicate noise levels satisfactorily and therefore are inadequate for sensitivity tests.

4. Disconnect the antenna lead-in from the receiver. Connect the signal generator output to the antenna lead-in connector with or without a dummy antenna as the impedance matching requires.

CW Sensitivity

A means must be provided to set the output beat note of the receiver to the standard 1000-Hz frequency with an accuracy of ± 50 Hz. When a receiver has a 1000 Hz "Sharp audio filter," centering of the tone at the receiver resonant frequency is sufficient. The narrow bandpass frequency, created by the sharp audio filter, permits this technique. Where there is not a sharp audio filter, the 1000-Hz internal tone modulation frequency of most signal generators is accurate enough and can be zero-beat against the output beatnote.

If an oscilloscope is available, the output of a calibrated audio oscillator and the output of the radio receiver can be fed independently to the deflection amplifiers of the oscilloscope to produce a Lissajous pattern of synchronization.

MCW Sensitivity

MCW sensitivity measurement requires the application of a carrier modulated 30 per cent at 1000 Hz. The receiver RF gain control should be set at maximum with the AGC on and the beat-frequency oscillator off. All other controls except the AF gain should be set as though the receiver were adjusted for CW reception. When the preceding adjustments have been made, progressively adjust the input signal level at the signal generator and the a-f gain on the receiver until the receiver output noise level is 0.6 milliwatt (0.6 volt) with an unmodulated input, and the signal-plus-noise output is 6 milliwatts with modulation on. When the 0.6 and 6 adjustments have been completed, receiver sensitivity in terms of input voltage is read from the signal-generator voltage calibration.

(3) Procedure For Determining Receiver Selectivity

Receivers with less than 5-kHz bandwidth at 6 dB down

Connect a high impedance voltmeter across the final-detector diode load of the receiver. Place a 1-megohm isolating resistor between the "high" lead of the voltmeter and the diode load (high with respect to ground). Possibly the resistor will not be necessary;

its purpose is to eliminate regeneration and other undesirable effects.

Connect an RF signal generator with an unmodulated output to the antenna input of the receiver. Beginning with the standard input voltage, increase the signal generator voltage output in steps of about 1.4, 2, 3, 5, 10, 100, and 1000 times its standard input. At each step, the frequency of the signal is adjusted to produce the same detector diode voltage as previously obtained with standard input at resonance.

Procedure:

1. Set the signal generator output at a specified low level.

2. Tune the receiver to resonance at the same frequency as the signal generator.

3. Increase the signal generator output until the detector output of the receiver (as indicated on the voltmeter) is 1.4 times the specified low level.

4. Detune the receiver to one side of its center frequency until the voltmeter reading equals the specified low level and record the frequency shown on the receiver dial.

5. Rotate the receiver dial in the opposite direction through the 1.4 point until the specified low level is again indicated on the voltmeter. Record this receiver frequency dial setting.

6. Subtract the lower frequency-dial setting from the higher one to obtain a bandwidth.

7. Find a bandwidth at the next higher level by (1) increasing the signal generator until the voltmeter reads twice the original specified low level; (2) detuning the receiver until the detector output is 1.4 times the specified low level, (the first peak-voltage setting); (3) determining the 1.4 points on opposite sides of the center frequency, and (4) subtracting the lower from the higher frequency reading.

8. Repeat similar bandwidth measurements at 3, 5, 10, 100, and 1000 times the specified low-level input; each time follow the same order of clockwise and counterclockwise approaches to frequency limits. Each time detune to the previous level to determine a bandwidth limit. A "times resonant specified input" versus "kHz off resonance" curve may be plotted on semilog paper. The 6 dB down and 60 dB down bandwidths of this curve will show the 60 to 6 dB bandwidth ratio or selectivity ratio.

Receivers with more than 5 kHz bandwidths at 6 dB down

In general, the selectivity of TRF and single-conversion superheterodyne receivers designed for operation above 500 kHz may be measured with a carrier that is modulated 30 per cent by a 400 or 1000-Hz tone. The procedure is the same as the selectivity measurements of receivers with less than 5-kHz bandwidth at 6 dB down. The output measurement, however, is made at the audio output terminals of the receiver and not at the final detector output load.

Bandwidth Tests at 3 dB down only

Ordinarily time does not permit a complete selectivity test, but bandwidths are checked at 3 dB down points at high, mid, and low portions of each band. The procedure is the same as for the selectivity tests, except that detuning is from 2.0 to 1.4 levels only. A typical POMSEE measurement requires a 2.0-mA peak adjustment at the output load of the final detector with detuning to a 1.4 mA on each side of the center frequency.

1-13 SUPPLEMENTARY DATA

The function of this subsection is to record maintenance and operational information of a general nature that has been generated since the revision of Section 1. Information will not be organized under subject categories but will be subjoined to this section as future changes are issued.

a. Buoyant Cable Antennas—Preparation of Spares

Submarines having the inboard recoverable buoyant cable antenna installed usually carry spare buoyant cable and spare termination tips, but no spare UG-1820/U connector. The UG-1820/U connects the buoyant cable antenna to the rotary coupler in the hub of the reel. In the event of a casualty to the antenna the UG-1820/U must be disassembled on to the spare cable before a new antenna can be deployed. This routine takes 1-1/2 to 2 hours.

The time required to stream a replacement antenna after a casualty can be significantly reduced if spare UG-1820/U connectors are carried on board as well as the usual cable and termination tips. One or more antennas can then be assembled which would be ready for immediate use. The cable guide on the front of the reel should be modified as shown in Figure 3-II-B14 of Handbook for Submarine Antenna Improvement Program, USL Report 551B, so that the UG-1820/U can be passed through it while attached to the antenna.

The UG-1820/U is available from stock under FSN 5935-247-0745 at \$3.00 each. (796)

b. Wire Rope Antennas—Increased Life Using Improved Materials

This article outlines procedures which are NOT acceptable for cleaning wire rope antennas on surface ships. Methods and procedures which may enhance appearance or are easy to apply, but result in eventual deterioration of the wires, shall NOT be used. NAVSEC has designated that vinylite jacketed wire rope is to be used in new and replacement installations; therefore, cleaning of old unjacketed wire rope is unnecessary.

In the procedures used previously, only the outside of the wire lay was in a position to be wirebrushed and, consequently, a large

amount of the noise producing copper salts and oxides (rectifiers) remained between the strands and in the central fibre core. Covering the brushed wire with a combination of greases, white lead, and other compounds delayed more corrosion, but it did not neutralize the remaining salts. Also, wire brushing may break some strands of the wire and allow them to become noise sources from corona.

Activities specifying an acid or "brightener" dip for the wire rope realized that wire brushing could not reach between the wire strands and, therefore, a liquid cleaner would give a cleaner and more uniform appearance. In theory, one would expect to clean the major part of every strand except for the contact points to adjacent strands; however, it is the salt at just these contact points which give the most trouble to radio frequency currents. It is doubtful that the difference in generated noise products between the two cleaning methods could be noticed. The acid or "brightener" dip has a hidden and long term problem which may not be evident until some future date when ship's personnel are injured by a falling wire. A SAFETY HAZARD exists after an acid bath or "brightener" dip due to a residue remaining in the fibre core of the wire rope and continuing to etch the strands until they break somewhere along the length of the antenna. (810)

c. Wire Rope Antennas—Cleaning and Preservation; Cleaning Precautions

With the increasing use of vinylite jacketed wire rope for installation of wire antennas, it is necessary that activities be aware of this improved wire and the best techniques for maintaining its watertight integrity. This article will give the general approach and particulars for sealing out water at all connections. Refer to the September 1970 edition of the Shipboard Antenna System Details (Volume 2) NAVSHIPS 0967-177-3020 for the Mil Specs which apply and the ordering procedure. Paragraph 2.2.1 refers to the 5/16 inch wire rope for transmitting (approved source), and paragraph 2.2.2 specifies FSN 6145-542-6519 for 1/8 inch wire rope with vinylite jacket for receiving.

The installation of jacketed wire rope in conjunction with the sealing procedures in this article will eliminate monthly maintenance, and quarterly PMS will be little more than a visual inspection for weathertightness and the normal meggering of insulators.

Activities anticipating antenna overhaul should, several months in advance, submit a non-stocknumbered requisition to ESO for both the vinylite jacketed wire and several quarts of Scotch Clad #1706 (gray or black) preserva-

tive coating (6 months shelf life). If the assorted connecting hardware currently installed has been uncoated in the weather for a year or more, it may be more economical in manpower and effort to requisition new hardware rather than to clean up the old.

Figure 1 is a typical wire rope connection block which was prepared using the procedures of paragraph 2.4 in Volume 2 of the Shipboard Antenna System Details and the improved materials of this article. Silicone grease, DC-5 (FSN 6850-963-5402) is substituted for the Hard Film Gun Slushing Compound in paragraph 2.4.c, because of its availability in a tube and ease of application and removal. The arrows in figure 1 point to the white silicone rubber, RTV-731 (FSN 5330-842-6380) or RTV-102 (FSN 8040-225-4548), which is forced into the gaps between the connector plates after final assembly and tightening of the bolts. If excess DC-5 is evident on the vinyl jacket at the point of entry to the connector, wipe clean with solvent dampened rag before forcing silicone rubber into the adjacent cracks and around the wire to completely seal the connector.

Allow the silicone rubber to harden overnight. Now, preserve all watertight connectors with at least two coats of Scotch Clad 1706 while on the open deck. Read the label on the can first. Store in the paint locker with other volatile solvent compounds (6 months shelf life). Apply the Scotch Clad 1706 with a 1 or 1 1/2 inch paintbrush (throw away when through) so that the hardware and 3 or 4 inches up the vinyl jacket are 100% covered. Apply a second coat at least 30 minutes later, assuring that all cracks at bolt heads and washers are sealed as well as wire entry points.

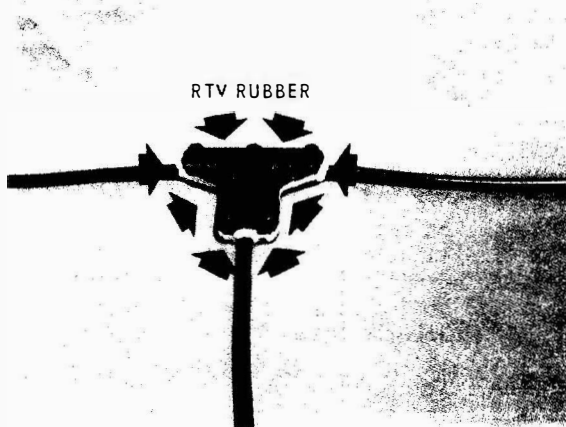

Figure 1. Connector Plates Sealed with White Silicone Rubber

No bare metal should be exposed to the weather; even jacketed wires used for safety links and downhauls must have a good coating at the ends to prevent water from wetting the wire and "wicking" the length of the wire under the jacket.

Scotch Clad 1706 is stronger than paint and of such consistency that gaps can be bridged, as are found around all threaded fasteners, and seizing, caused by salt intrusion, can be prevented at any connection whether it be antenna or not.

In reference to the whip antenna preserving article in EIB 785, note that Scotch Clad 1706 will probably make a stronger seal around the large mounting bolts which were shown covered with DC-1890. Comments regarding this procedure can be sent to the Naval Ship Engineering Center, Norfolk Division, Code 6621, Naval Station, Norfolk, Va. 23511.

This procedure supplements the PMS now in the Fleet. The PMS will be updated to include this procedure. (810)

d. Magnesyn Compass Transmitters in Submarines— Adjustment of

Normal adjustments of magnesyn transmitters in submarines have long presented problems due to the necessity for opening the

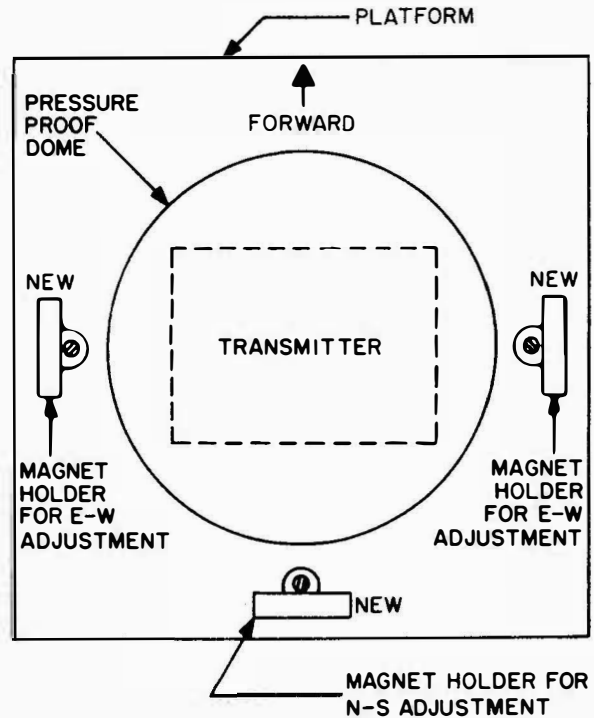

Figure 1. Method of Mounting Corrector Magnets

pressure proof dome and the watertight enclosure of the transmitter. This is particularly difficult at sea and also exposes the equipment to damage by the elements.

To permit rough adjustment of the transmitter without opening the equipment enclosures, some activities have mounted corrector magnets outside the pressure proof dome. This method can also be used for corrections beyond the range of the internal correctors.

One such method, devised by the Pearl Harbor Naval Shipyard, is shown in figure 1. This method employs standard corrector magnet holders and fascicular cobalt corrector magnets with the amount of correction determined by the number of wires used in each holder.

Material required:

Three corrector magnet holders (FSN 1H6605-369-4425) and one corrector magnet set (FSN 1H6605-211-6746). (815)

e. Dummy Plug for Teletype Panel

The common practice of using a patch plug or one end of a patch cord to open loops or isolate equipment in a TTY patch panel is unsafe.

Not only does this practice present a dangerous shock hazard, but it does not always provide proper isolation of equipment or TTY loops. This unsafe practice can be avoided with the use of an appropriate dummy plug.

The dummy plug is available in the supply system under FSN 9N5955-642-0743 at a cost of \$.17 each. In this case "Each" represents a package of 5 dummy plugs. (800)

f. IFF Antennas DC Resistance-Information concerning

There appears to be a need to summarize the DC resistance characteristics of all available IFF antennas, as follows:

<u>Antenna</u>	<u>DC Resistance Notes</u>
AT-352/UPA	HIGH-Over 20 megohms;
AT-352A/UPA	measured at antenna input.
AT-352B/UPA	
AS-1065/UPX	LOW-Essentially a short; less than 5 ohms. See EIB #767, 15 Dec 1969, P. 13 and EIB #776, 20 Apr 1970, P. 12.

Antenna DC Resistance Notes

AS-1688/SPS-48(V)	LOW-Approximately a direct short, as measured at either the hybrid or the antenna inputs. Hybrid can be separated from the antenna inputs, or may not be used, in some installations.
AS-2188(XN-1)/U	HIGH-Over 20 megohms, measured at either the sum or the difference input to the hybrid. Hybrid is tied directly into the antenna and cannot be separated.
AS-2188/U	
AS-2189(XN-1)/U	
AS-2189/U	
AS-2787/U	LOW-Essentially a short circuit, as measured at the antenna inputs. Hybrid can be disconnected from antenna.

CAUTION

If there is an RF switch in the line, DO NOT use a megger, as it will burn out the switch diodes. Also, the DC resistance measurement will be in error.

AS-177	LOW-50 ohms or less. See Note 1
AS-177A	HIGH-Over 20 megohms. See Notes 2 and 3.
AS-177B	

NOTES:

1. Early versions of AS-177A antennas mount on 1" extra heavy pipe (1.315" OD); others require 1-1/2" extra heavy pipe (1.900" OD).
2. AS-177A mounts on 1-1/2 x 11-1/2 threads/inch extra heavy pipe. AS-177B uses same size pipe but requires no threading.
3. AS-177 TM NAVSHIPS 92642, which became NAVSHIPS 0967-958-0010 by cover sheet, states "resistance of antenna and cable should be negligible." Quite the opposite. T-2 to NAVSHIPS 92642 (Aug '63) and T-3 to NAVSHIPS 0967-0010 (Mar '67) correctly state "resistance should be HIGH."

g. Degaussing Rectifier--Power Supply Maintenance

The following maintenance article applies to Type GM-1A International Telephone & Telegraph Corporation Automatic Degaussing Equipments on DDG 2 C1, DLG 6 C1, DLGN 25 and 35, CGN 9, and LPD 1 C1 ships.

Data Period, Type, Source:

January 1971 through August 1972. Material History Report, Maintenance Support Office, 3M/MDCS, Report No. 4790.S2704.A-08

Maintenance actions for International Telephone and Telegraph Corporation, Type GM-1A automatic degaussing equipment for the period January 1971 through August 1972 have been reviewed. This review was instigated as a result of excessive failures of the main power rectifiers in the degaussing M coil power supplies as noted from CASREPTS.

Discussion:

An excessive number of failures of the main power rectifiers in the degaussing M coil power supplies have been noted in recent months with practically no failures of the corresponding rectifiers in the FPQP coil power supplies. Both units are of the same type, differing only in rating and in method of cooling. The M coil unit is a 25 kilowatt, blower cooled unit while the FPQP unit is rated at 5 kilowatts and is convection cooled. Both units are located in the same general area in the machinery spaces and should be expected to require about the same degree of corrective maintenance. Analysis of the data contained in a Maintenance History Report for the period January 1971 through August 1972, however, shows that 90 main power rectifiers were replaced in the M coil power supplies compared with only two replacements in the FPQP coil units. Based upon common conditions found on a number of ships recently, this disparity is attributed primarily to high temperatures inside the M coil power supply cabinet resulting from the reduction in the flow of cooling air through the cabinet caused by clogging of the air filter with an accumulation of dust and lint particles. The condition of the air filters as found during inspection indicates that the air filters were not being inspected and cleaned as required by the Planned Maintenance Sub-System. Because of the high temperatures the temperature sensitive rectifiers experience increased internal losses which accelerates aging effects and results in premature failure, as evidenced by the large number of replacement rectifiers required.

Maintenance Hint:

To obtain the maximum service life from rectifier components, it is recommended that the air filters on all units be inspected and cleaned in accordance with the requirements of Maintenance Index pages EL-20/10-30 or EL-20/10-A2, as applicable. These documents require a quarterly cleaning of the filters. This recommendation, while based upon conditions and maintenance data from degaussing power supplies, is equally applicable to all other forced air cooled static power supply equipments having air filters. Related to this, ships force should ascertain that the Equipment Guide List (EGL), required for the EL20 - Quarterly Maintenance Requirement Card, is completed to ensure that all applicable static power supplies are covered and rescheduled accordingly. (EIB 855)

h. Unauthorized Topside Alterations

(This article is condensed from the NAVSHIPS TECH NEWS March 1973 issue)

Every ship requires dependable communications to perform assigned missions effectively. A ship is useless as a combat system, a repair vessel, an aircraft carrier, or a harbor tug if it loses its ability to communicate. In recent years the volume of shipboard communications has increased dramatically. This rapid expansion has led to the development of increasingly sophisticated equipment which places high demands on system parameters. To handle this increase in an organized and thorough manner, each class of active ships has undergone, or is presently in the process of undergoing, extensive communications antenna system design. This design views the ship's topside as a total system, incorporating inputs from the MIP (Military Improvement Plan) and the FMP (Fleet Modernization Program). The design also considers all known future installations on or changes to topside structures including weapon systems, radar systems, replenishment systems, or any system requiring topside space, and arranges the antenna system so that whenever one of these future systems is installed the impact to the existing antenna system is minimized.

The communications antenna system is not an isolated, independent system. It must be tailored carefully to a particular ship type so that it can operate effectively within the general constraints of space, weight, high ambient rf fields, and in direct competition with other users of the ship topside environment. The entire ship, from the top

of the mast to the waterline, is a complex sheet of interacting rf current streams comprising the antenna system and has a direct influence on individual communications antenna system performance characteristics. Antenna radiation pattern, feed point impedance, and intercoupling data depend not only on frequency and the antenna location, but also on the surrounding structures. The restricted area available on ships for placing antennas causes most of the communications antennas to be affected by the presence of adjacent radiators and parasitic structures. Examples of topside modifications which can seriously affect antenna performance include adding deck houses; mast and yardarm configurations revised by Christmas lights, wires, rigging of mast lights, etc.; antenna additions, deletions, or relocations; changes in communications antenna couplers or filters; and alterations to weapons or ECM and radar system location.

Due to the magnitude of factors having influence on an antenna, the quickest (at least for the LF, MF, HF and VHF frequency ranges), as well as the most cost effective, method of checking out an antenna is to measure the electromagnetic parameters on a suitably prepared model. There is often considerable apprehension, by forces afloat, that a laboratory-controlled solution may not work in the real world. However, years of experience have verified that data gathered by model testing will closely parallel actual shipboard testing, provided topside structures have not been altered or added. Modeled antenna-arrangement designs that have been closely followed during ship construction or overhaul can be made ineffective by topside modification (such as unknowingly erecting parasitic structures or tweaking a matching network) performed by shipyards or operating forces who are unaware of the consequences of their actions. Indeed, an individual system might operate more efficiently but the total ship's antenna system could be substantially degraded.

To ensure satisfactory performance from an antenna placed in the best location available, the installing engineer must have a good understanding of the complex electromagnetic nature of interacting, undesired coupling between the antenna and other topside objects. Each antenna is custom-fitted to its environment and then becomes a victim of that environment. Any attempt to alter the topside in a piecemeal manner without analyzing the effects on other systems would be a reckless attempt at solving a problem. If a problem exists, the proper approach toward a solution is to contact the Ships Logistics Manager, who can in turn task NAVSEC to provide analysis and a solution.

For additional information about why unauthorized topside erections may cause more problems than they solve, the readers are referred to the informative publication "Shipboard Antenna Systems-Communications Antenna Fundamentals," Volume No. 1, NAVSHIPS 0967-177-3010, September 1972. (This document updates NAVSHIPS 900121(A) "Shipboard Antenna Details, Chapter 1, Antenna Fundamentals" dated 1 June 1958). (EIB 855)

i. Broad-Band Interference Generation in Ship's Topside Structures

Recent fleet reports have indicated serious HF communications problems due to self-generated ship interference. This interference is characterized by intermittent noise bursts which affect a large part of the HF frequency spectrum. Non-combatant type ships with large amounts of running rigging used for underway replenishment purposes are particularly susceptible to this problem.

The sources of this problem have been identified as various topside metallic objects rubbing or touching each other intermittently while ship transmitting antennas are energized. The cause of the problem is the currents induced in these objects, as a normal consequence of antenna radiation. The sudden changes in currents produced by the make and break contact between these items produces spikes of noise which can be heard continuously across a wide frequency range. The problem is especially bad where whip antennas, operating with inputs of 1 KW, are located atop kingposts supporting UNREP rigging. The kingpost becomes part of the radiating system, thus inducing high voltages in span wires and outhauls. Ship's speed, humidity, relative wind velocity and temperature can have a strong influence on the generation of broadband noise.

There is no simple cure for this interference but a number of fixes can be employed, depending on the circumstances, which will either eliminate or minimize the problem.

A major consideration is the stowage of rigging involved with UNREP and cargo handling equipment. Such equipment should be stowed in a manner to minimize rubbing, scraping, or bumping between metallic components. Out-hauls, span wires and other cables should be pulled taut and tied off with nylon or hemp rope.

The use of non-metallic hardware such as life lines, safety nets, stanchions, etc. eliminates the possibility of metal to metal contact. In some instances, it may be more economical to completely insulate a metallic

object from the surrounding structure than to replace it with a non-metallic one.

Transmitter power in excess of the level required for good communications should not be used. Operating transmitters at maximum power greatly extends the area in which metal objects will sustain induced voltages, and thus become capable of producing broadband impulsive noise. Circuits carrying heavy traffic should be routed to antennas furthest removed from areas where running rigging is installed and handled.

Long term remedial action includes the installation of broadband antennas and receiving and transmitting multicouplers. The reduction in the number of antennas will permit the antenna arranger to reduce EMI problems by increasing the separation between susceptible areas and transmitting antennas. (EIB 862)

j. NTDS Computers, Data Displays, Peripheral and Communications Systems Cooling Water Temperatures--Information Concerning

NAVSECNORDIV representatives visiting NTDS equipped ships and stations have noted many instances where cooling water supplied to subject systems was being maintained at temperatures as low as 55° F. Since these temperatures are obviously far below normal ambient temperatures of associated equipment spaces, condensation frequently occurs on interior equipment surfaces causing corrosion, arcing in high voltage circuits and eventual equipment failures. This is especially true in ships operating in high humidity environments.

The purpose of this article is to correct the false assumption of many cognizant maintenance personnel that the foregoing cooling water temperatures are normal and to ensure that all NTDS maintenance personnel adhere to the following:

1. Maintain cooling water supplied to subject systems equipment heat exchangers at a temperature of 73° F ±3°.
2. Align circuits only when equipment operating temperature has stabilized with cooling water temperature maintained within the foregoing limits.
3. Become generally familiar with the capabilities of own ship's cooling water temperature control system. (EIB 879)

k. Loudspeaker Testing in Shipboard Announcing Systems

Loudspeaker testing on shipboard announcing systems is commonly accomplished by requesting the OOD to make a count test; defective speakers are identified by their low volume or total failure to produce any sound. While this test method is effective, it is also inconvenient because it requires the active participation of the OOD, and because it unnecessarily energizes all the speakers in the system in order to test a single speaker, resulting in annoyance to the rest of the crew.

A better method of testing individual speakers is to temporarily disconnect the speaker from the ship's wiring, and then connect an audio signal generator (such as the AN/URM-127 or the CAQI-201C) to the high voltage side of the transformer (terminals MC70V and MCC COM). When the signal generator is adjusted to deliver a tone of about 1 KHz, at a level of 30 to 50 volts rms, a loud sound will be produced in a properly operating speaker. In this manner, the announcing system loudspeakers may be tested one at a time, with minimum annoyance. (EIB 863)

l. Teletypewriter Equipment--Maintenance Hint

The purpose of this article is to provide information concerning stock numbers for lubricants and cleaning agents specified on Maintenance Requirement Cards for teletypewriter equipment.

The federal stock numbers for these lubricants and cleaning agents may be found in the Electronics Installation and Maintenance Book (EIMB), General Maintenance, NAVSHIPS 0967-000-0160, tables 3-3 and 3-6. Quantities of lubricants required is to be determined by using activities.

Lint free rags may be ordered under Federal Stock Number 7920-401-8034, package of 100.

Federal Stock Number 9150-252-6173 specified in EIB 798 dated 22 Mar 1971 is for a non-fluid oil which is intended for use with "Mite" TT-299/UG series equipment. This oil is not to be used on Model 28 Teletypewriter equipment.

Inclusion of this information will be recommended for future revision of Teletypewriter Maintenance Requirement Cards.

(EIB 885)

m. Weatherproofing and Corrosion Prevention of Topside Hardware—Additional Details to EIB 854

The article in EIB 854 was enthusiastically received and many comments were contributed--both pro and con.

The con comments are all about a single point--SAFETY. All hands have been advised many times to be careful of solvents--a particular case is carbon tetrachloride, a popular cleaner and fire extinguisher of a few years ago now replaced by a "safe" (but not very) solvent O-T-620C (trichloroethane 1,1,1). Section 413 of NAVSHIPS 9600 is quite illuminating in regard to the explosive and suffocating properties of any gas, particularly the evaporative products of cleaners, paints, pocket cigarette lighter fluid and "safe" solvents. NAVSHIPS 9600.413 is one page of real everyday information. "Safe" solvents such as trichloroethane (methylchloroform) mentioned in the first EIB article are absolutely forbidden on submarines and must be stored in a paint locker on surface ships. Equally hazardous are spray cans of anything. Freon (which is the most used spray can propellant) is taboo on submarines and combined with paint/solvent it makes a first class hazard for below decks use on surface ships. It is recommended that spray cans of solvent be maintained at a minimum level and issued to working personnel for topside and aloft use only.

The pro comments encouraged publication of more weatherproofing techniques. This article is to standardize the installation and preservation of connectors which are exposed to water and salt spray. With this procedure for protection of connections corrective maintenance can proceed quickly and without worry that a corrosion problem is hidden inside the connector.

Proper preparation of connectors used topside will insure long life. The next time a chassis connector is removed during corrective maintenance put it back using this technique. Wire brushing, solvent clean, Permatex II and a final coat of paint make a tight seal against corrosion and minimize connector replacement and chassis corrosion. Note that

the connector, either "nut" type as in figure 1 or "flange" type as in figure 2, has Permatex applied at time of assembly into the case. Sealant dabbed on later and painted is only effective against direct water entry and its corrosion, but for pressurized cabinets it must be applied between the case and the connector. Applied this way even a moderately tight enclosure is effectively sealed if pressurized.

The following procedure is suggested as a method for sealing cable connectors such that removal of sealing material is easy and leaves the connectors clean and not full of sticky sealant. (Add a ground wire to the connector if the wires inside don't have shrinkable sleeving over each soldered connection as required for Safety in MIL-STD-1310C.)

1. Ensure connector is clean and dry.
2. Apply a light coat of silicone grease (DC-5 or equivalent, NSN 6850-00-963-5402) to connector threads.

3. Reconnect connector plug.

4. Cable armor causes wicking of salt water into the pins if the armor is secured under the connector clamp back. If armor is present cut the armor back 4 inches from the connector, add a ground strap about 6 inches from the connector and serve the end of the armor and new ground strap clamp with vinyl tape. See figure 3.

5. Using silicone rubber (self-bonding) tape (NSN 5970-00-955-9976) wrap an overlapping layer from the panel to the cable. Make sure holes of the connector at the cable clamp are covered and continue the tape about 2 inches onto the cable. See figure 4.

6. Using vinyl plastic tape (NSN 5970-00-284-8410 typical) wrap the connector with one or two layers from the panel to the armor. Pull the tape tight and overlap about one half.

7. Apply at least two coats of Scotch-kote (NSN 5970-00-962-3335) from the panel to the cable. The Scotchkote is designed to protect vinyl tape from the weather; regular paint and other coatings will soften the tape and cause it to unwind. See figure 5.

The explanation for the two different kinds of tape is that the first layer won't stick to the connector and the second layer plus the Scotchkote provides strength and

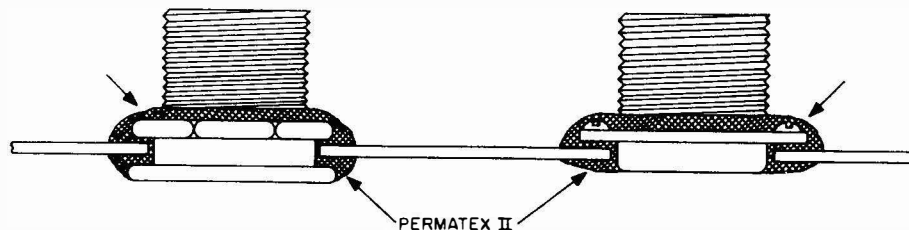

Figure 1. Nut Type Connector

Figure 2. Flange Type Connector

weather tightness. A jackknife will lay open this cocoon with a straight lengthwise cut leaving the connector in original condition with no stickness or clogged threads.

Don't forget to tape over or plastic bag any cable connector removed and to be left unconnected overnight. Rain and salty air can begin building an insulating layer on the pins pretty quickly.

A couple of precautions with Permatex type products:

1. The stock system type II was coming through too thin for awhile. GSA was notified last year.

2. All three types are almost impossible to remove from clothes.

3. Don't use on gaskets (even edges) that are to be reused. Use DC-4 or 5 on reusable gaskets unless something else is already specified.

4. Type III really sticks; keep it away from nut and bolt threads.

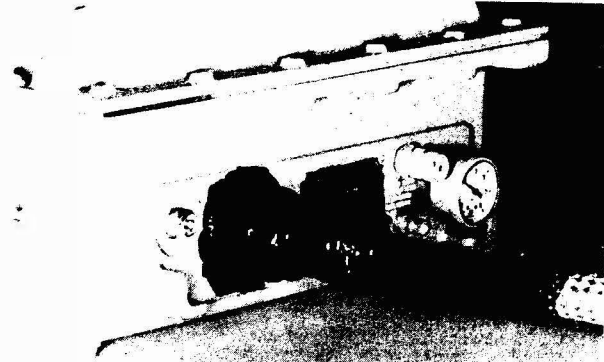

Figure 5. Application of Scotchkote

(EIB 896)

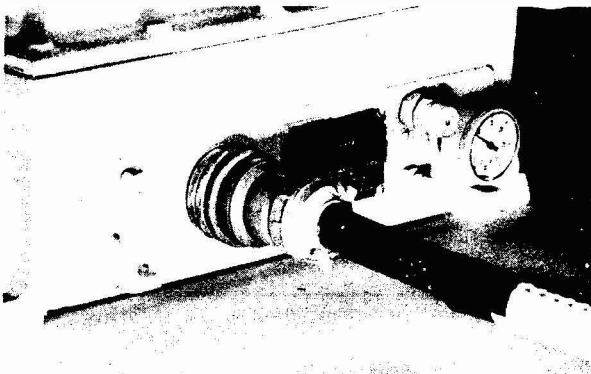

Figure 3. Removal of Cable Armor

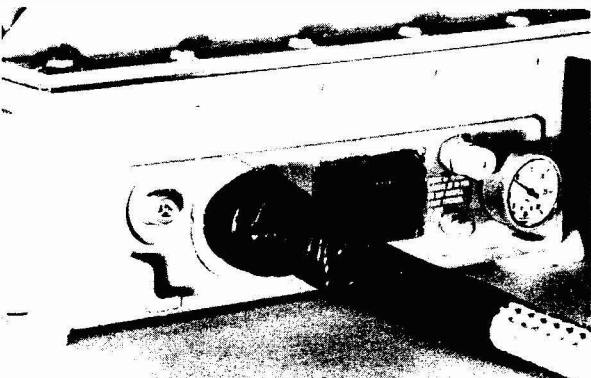

Figure 4. Taped Connector and Cable

n. Cable Terminating Aid for Terminating Block for
IDF/ MDF

The terminating block shown in figures 1 through 3 of this article is recommended to facilitate the terminating of cable on an IDF/ MDF block. With the use of the terminating block (figure 2) dressed wire ends to be terminated are held firmly in place, thus eliminating the need to relocate color-coded wires that have already been determined. The terminating block allows neatness of finished work, thereby decreasing the possibility of a defective termination. Construction of the terminating block is in accordance with figures 2 and 3.

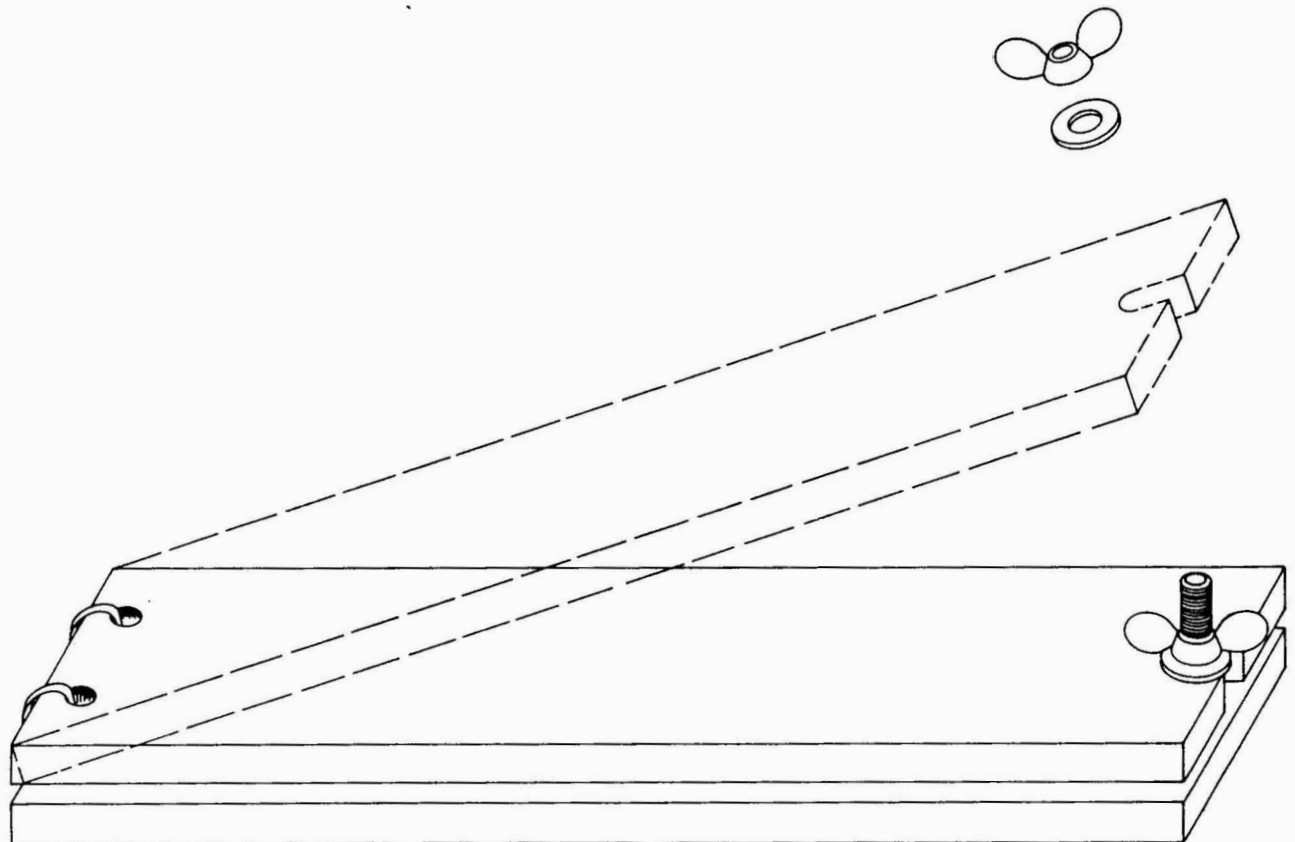

Figure 1. Terminating Block for IDF/MDF

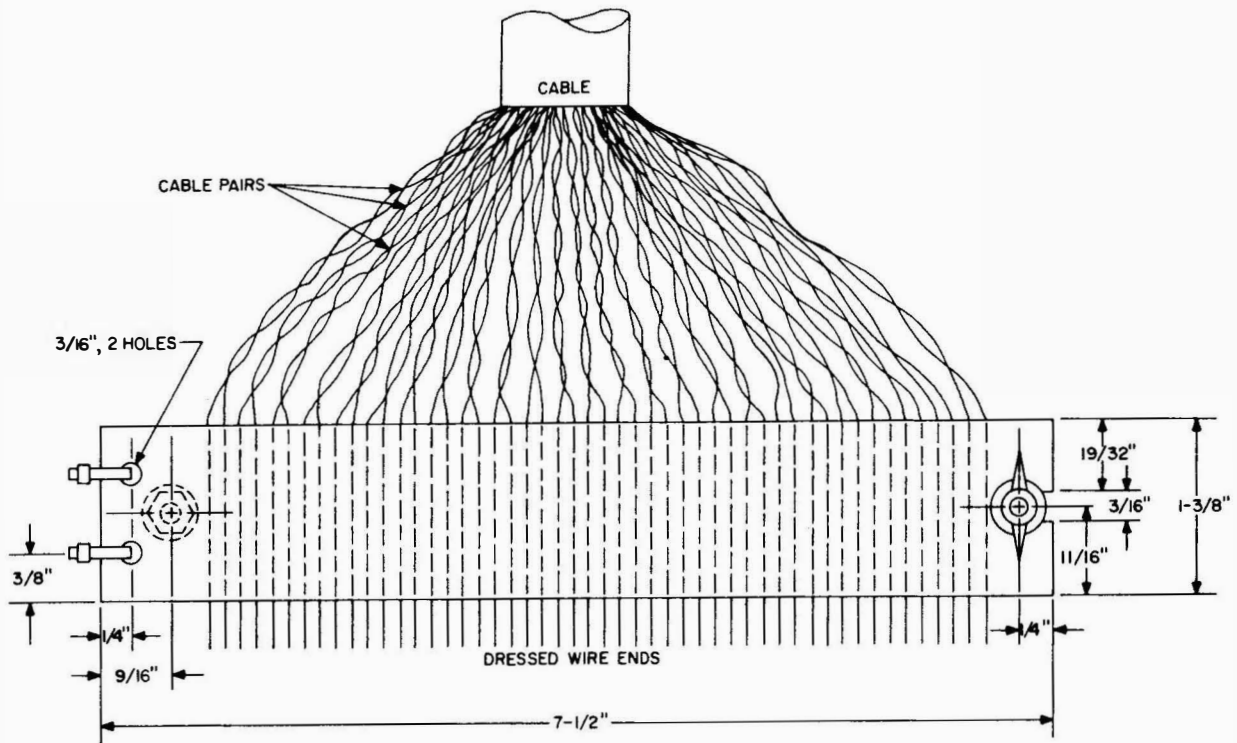
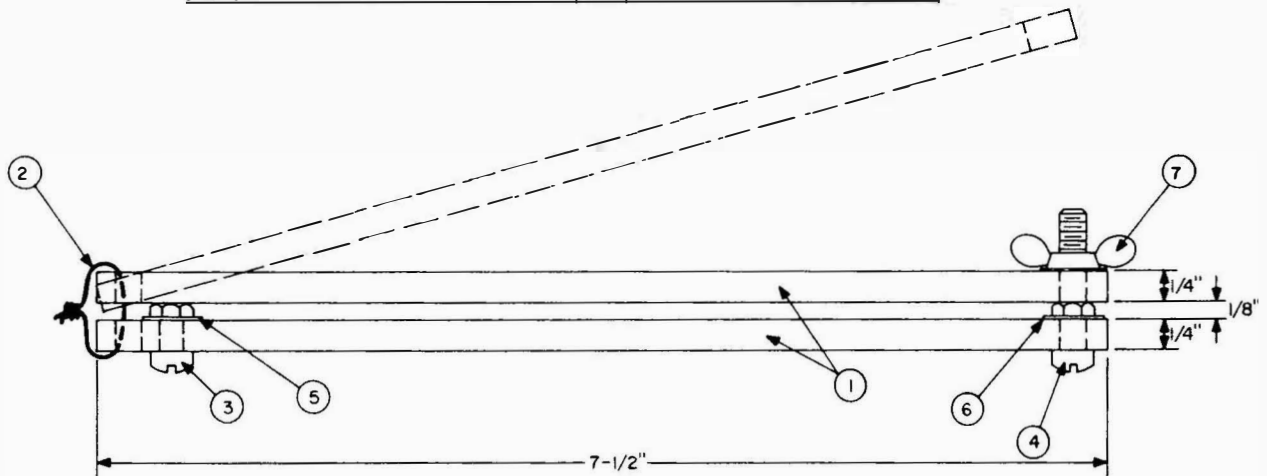

Figure 2. Construction and Use of Cable Terminating Block

LIST OF MATERIAL

NO.	DESCRIPTION	QTY.	REMARKS
①	LUCITE BLOCKS	2	
②	CABLE TIES	2	PAN-TY NO. PLT1M-CP (OR EQUIV.)
③	MACHINE SCREW, STEEL #10-32 x 3/8"	1	
④	MACHINE SCREW, STEEL #10-32 x 1"	1	
⑤	FLAT WASHERS, STEEL #10	3	
⑥	NUTS, STEEL #10-32	2	
⑦	WINGNUT, STEEL #10-32	1	



(EIB 896)

Figure 3. Materials and Construction of Terminating Block

o. HF Communications Antennas, Trussed Monopoles

Attention is invited to the fact that the Navy now recommends the use of two versions only of the trussed monopole HF communications antennas for shipboard installation. These antennas (known familiarly as "trussed whips") are:

a. A 35 foot three-wire open tip design standardized for operation from 2-30 MHz receive (or 4-12 MHz transmit).

b. A 15 foot four-wire open tip design standardized for operation from 10-30 MHz, receive or transmit.

These recommendations follow from an extensive study performed by the Naval Electronics Laboratory Center (NELC), San Diego and sponsored by NAVSEA 6102. Complete details necessary for construction of the two trussed monopoles and results of mechanical/electrical tests are contained in NELC Technical Document 376 of 1 December 1974 entitled Standardized Trussed Monopole Communications Antenna. TD 376 was widely distributed to Navy commands and shipyards; official requests for copies may be addressed to NELC San Diego CA 92152 ATTN: Code 2100. However, all requests for full size reproducible copies or prints of the antenna drawings appearing as figures 1 and 2 of TD 376 should be addressed to NAVSEA, Washington, DC, 20362, Attn: Code 614. (EIB 897)

p. Defective Rotron Muffin Fans in Teletype Equipment--Maintenance Hint

The purpose of this article is to recommend a maintenance action to relieve a possible deficiency present in certain Rotron Muffin Fans. The affected fans are labeled Mark 4 Series M-747 and are date coded between 9010 and 71480. The code is stamped on the outside of the venturi, or on one of the legs. A defective manufacturing process in these particular fans may cause arcing and momentary flashover of the plastic duct, resulting in the loss of fan operation. Mark 4 fans, other than as indicated herein, are not affected. The Rotron Muffin Fan Mark 5 is not affected.

The recommended action is to inspect the muffin fan during routine maintenance. If it is one of the affected fans, remove and replace with a new muffin fan, other than the affected series and date codes. (EIB 930)

q. MARS Operations Afloat--Authorization and Application Information

A recent issue of ALL HANDS magazine (March 1976) published an article "All About MARS" providing information on the system. NAVTELCOM INSTRUCTION 2371.1 of 6 October 1975 promulgates the policies, instructions, and guidance concerning the Navy-Marine Corps Military Affiliate Radio System (MARS).

Ships and activities desiring to apply for MARS operations should request application Form DD-630 from:

Chief, Navy-Marine Corps MARS
Bldg. 17, 8th & S. Courthouse Rd.
Arlington, VA 22204

Autovon 222-0393 or commercial
202-692-0393

The completed Form DD-630 (three copies) should be forwarded with a letter of transmittal originated by the command exercising military jurisdiction to the foregoing address. Information copies of the transmittal letter shall be addressed to the chain of command. Upon receipt of the DD-630 applications, the MARS office will forward a station license with MARS radio call sign, a copy of the MARS Communication Instructions NTP-8() and information concerning the established Maritime Mobile Radiotelephone/Teletype Network. (EIB 930)

Frequency Meter Replacement on IC Switchboard in Navigation Center--Availability of

The purpose of this article is to announce the availability from NSPCC Mechanicsburg, PA of a new 3-1/2-in. round frequency meter manufactured by the A & M Company to replace a present meter manufactured by the American Machine and Foundry (AMF) Company.

Most of the frequency meters which have been used in the Fleet were furnished by the AMF Company. Information received from the Fleet indicates that the 400 Hertz frequency meter on the I.C. switchboard in the navigation center on the SSN 637, SSBN 598, and SSBN 608 classes register incorrectly when the energy being monitored contains certain harmonics, even though the harmonic content is within acceptable ship specifications. A typical symptom reported is oscillation of the meter pointer at a rate which is obviously faster than reasonable. Sometimes the meter pointer

will "peg" off-scale when a load is applied. Another symptom of harmonic influence on the frequency meter is different readings on different phases.

Existing installations where the foregoing symptoms are observed can be corrected by replacement of the present frequency meter with the new meter manufactured by the A & M Company which is available from NSPCC Mechanicsburg, PA and identified by FSN 1N 6625-00-054-2143. (EIB 930)

S. Installation of Selector Magnet Driver

The purpose of this article is to provide Tempest criteria for the installation of a selector magnet driver (SMD) when such a device has been otherwise approved as a change to the teletype system. Many receive teletypewriter systems encounter excessively high signal distortion on teletype loops which can be reduced by the installation of an SMD at the input to the receive page printer. The SMD is essentially a relay which isolates the teletypewriter input circuit from the teletype loop. Prior to installation on non-metallic hull ships, commands shall assure that the use of the SMD is not in conflict with OPNAVINST

C5510.93B, enclosure (2), section 1, paragraph 1u (2).

Figure 1A illustrates a typical receive teletype circuit with both a page printer and a reperforator on the same loop. Figure 1B illustrates the insertion of the SMD at the input to the page printer in that loop. Figure 2 illustrates a typical box housing with flange type construction to provide adequate shielding. Figure 3 is an outline and mounting drawing of a typical box housing for the SMD. Figure 4 illustrates component mounting (assembly drawing) and interconnecting data.

Tempest criteria requires that the SMD be installed to provide adequate shielding to the driver and the interconnecting cables. The SMD shall be physically located as close to the associated teletypewriter as possible. Primary a.c. power for the SMD shall be connected to the primary a.c. power terminals of the existing teletypewriter. Only shielded cable shall be used for signal and power cables. Cable shields shall be bonded to ground at each end of the cables. The SMD box housing shall be bonded to ground via the mounting hardware to a foundation, shelf or cabinet which is already bonded to ground.

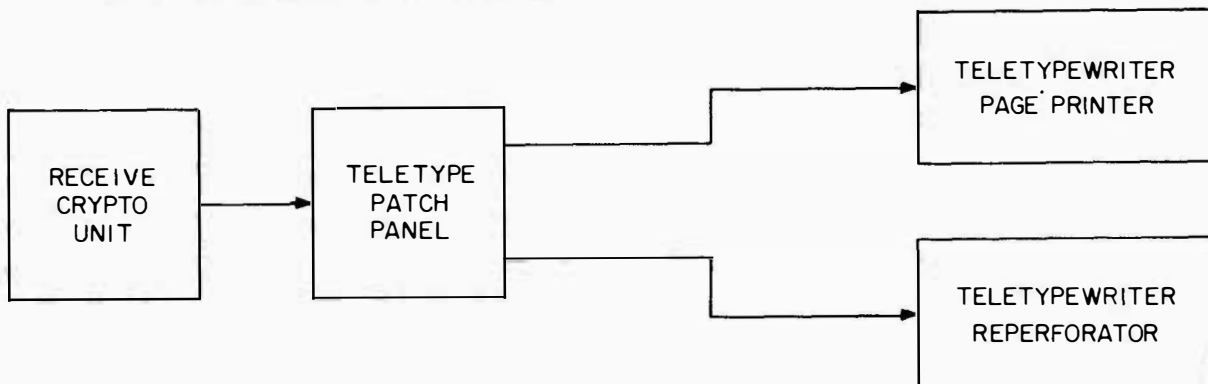

Figure 1A. Typical Receive Teletype Loop.

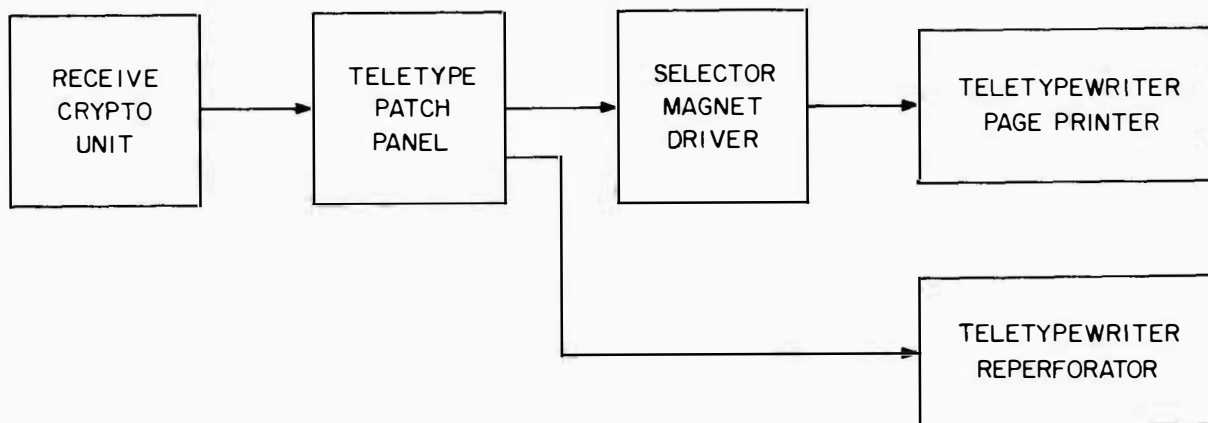

Figure 1B. Typical Receive Teletype Loop With Selector Magnet Driver.

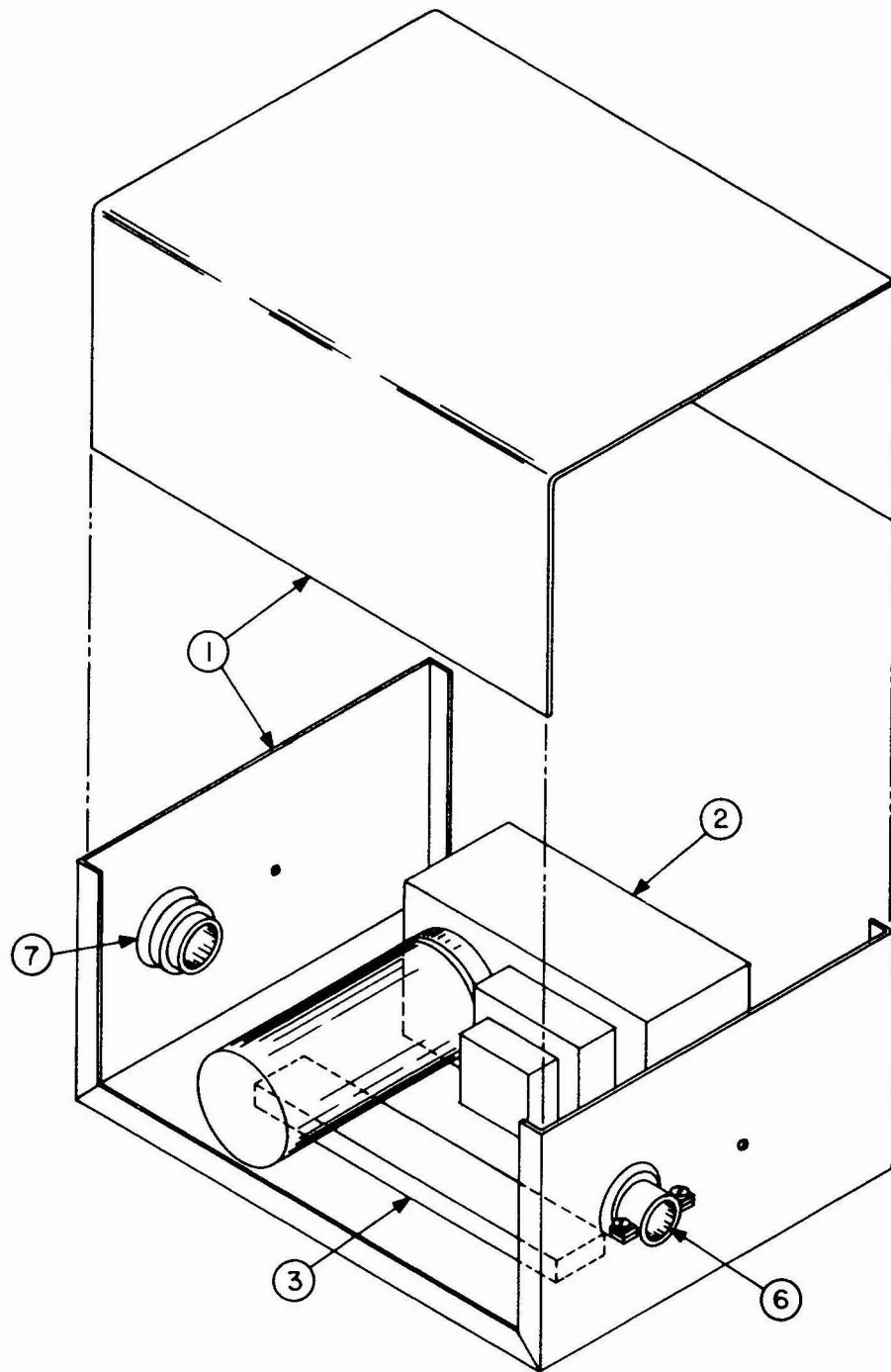
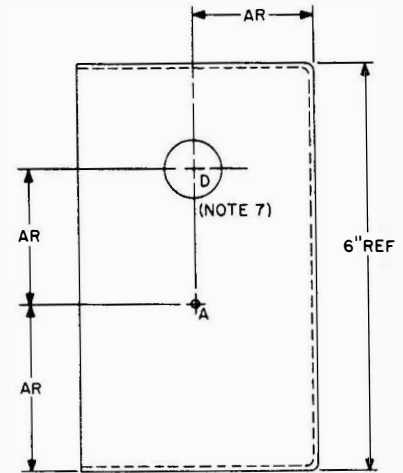
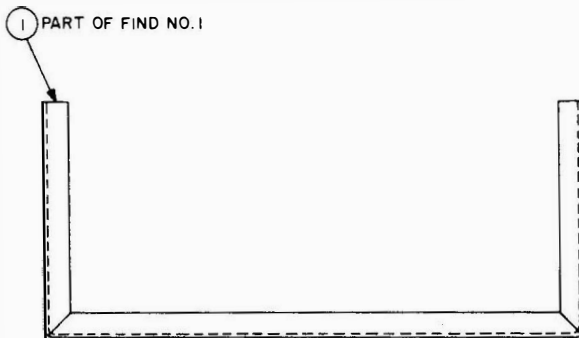
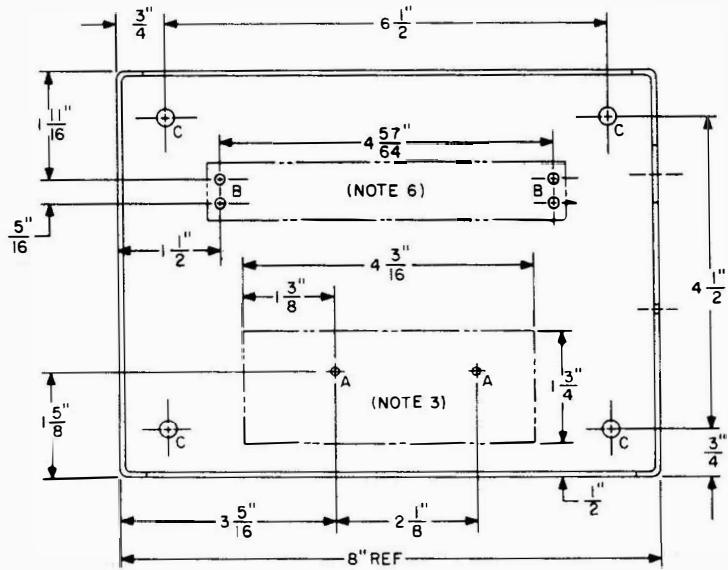
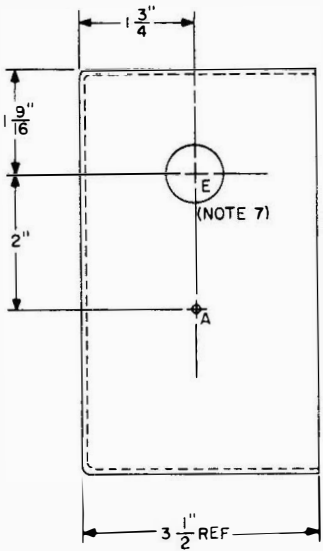

Figure 2. Typical Box Housing With Flange Type Construction.

1-98

ORIGINAL



HOLE SCHEDULE

LTR	SIZE	NO. REQ
A	9/64"	4
B	3/16"	4
C	5/16"DIA OR TO SUIT	4
D	5/8"	1
E	7/8"	1

Figure 3. SMD Box Housing, Outline and Mounting Drawing.

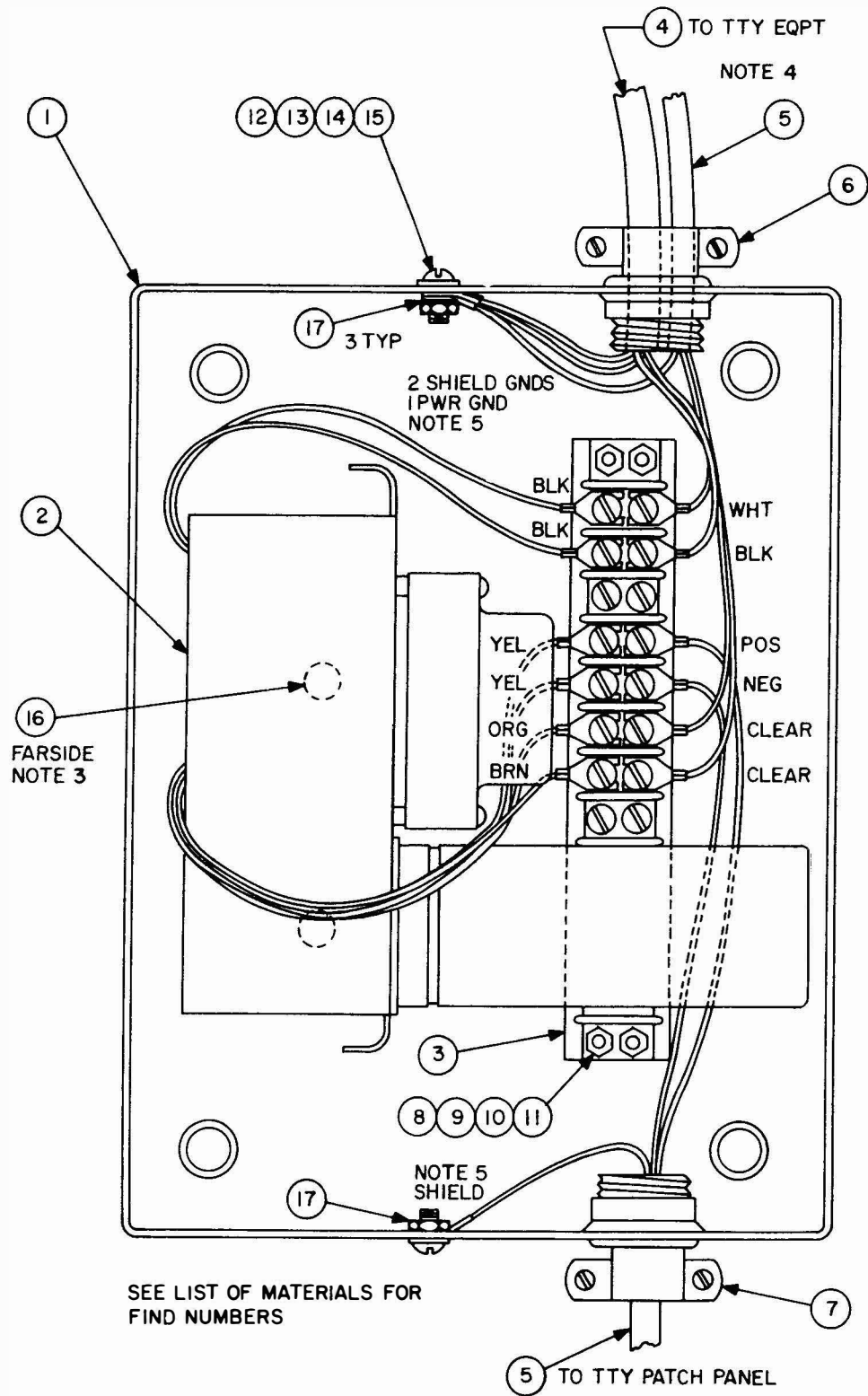

Figure 4. SMD Component Mounting (Assembly Drawing) and Interconnecting Data.

Substitution of items in the list of materials may be made providing the following essential criteria is maintained:

- a. Find No. 1. Box and box-cover must be metal. Cover, when in place, shall have metal-to-metal bond to the box.
- b. Find No. 2. Selector magnet driver. No substitution.
- c. Find No. 3. Terminal board shall have a minimum of six lug connections inside the box. Terminal board lugs shall accept wire size AWG 14 (for power) and AWG 28 (for signal).
- d. Find No. 4. Power cable shall be 3-conductor, minimum wire gage AWG 14, with overall shield.
- e. Find No. 5. Signal cable shall be 2-conductor, minimum wire gage AWG 28, with overall shield.
- f. Find Nos. 6 and 7. Box connectors shall securely fasten to the box and provide a snug fit for penetrating cables.

g. Find Nos. 8 through 16 mounting hardware may be substituted to suit component mounting holes.

h. Find No. 17. Terminal lugs may be crimp or solder.

The following notes apply to figures 2, 3 and 4:

1. All dimensions are in inches.
2. Locate the SMD box as close as possible to the associated teletypewriter.
3. Use these dimensions to locate holes in selector magnet driver (Find No. 2) cover. Mount selector magnet driver to box using sheet metal screws (Find No. 16).
4. Connect power leads (BLK & WHT) to existing teletypewriter equipment.
5. Connect cable shields and third wire power ground to case.
6. If substitute terminal board is used, match drill mounting holes using terminal board as template.
7. If substitute box connectors are used, drill to suit.

<u>Find No.</u>	<u>Qty</u>	<u>Description</u>	<u>HSN</u>
1	1	Metal box with cover for complete shielding, aluminum, 6 x 8 x 3.5 inches, Bud Radio Inc model OU-3009A, or equivalent.	
2	1	Selector magnet driver	5815-00-065-9728
3	1	Terminal board, barrier, screw type, double row, front connection (linked), rated voltage 300 volts, class 37TB12.	5940-00-983-6053
4	A R	Cable, power, 3-conductor AWG 14, overall shield, type 3SJ-14	6145-00-838-0005
5	A R	Cable, signal, 1-pair shielded, AWG 28 type RG-108A/U	6145-00-553-7823
6	1	Box connector, two-screw, for non-metallic sheathed cable .450 to .720 inch diameter, trade size 3/4-inch. T&B part no. 3303, or equivalent	
7	1	Box connector, two-screw, for non-metallic sheathed cable .187 to .500 inch diameter, trade size 1/2-inch. Appleton part no. BC-7286, or equivalent	
8	4	Screw, machine, slotted, steel cadmium plated, U NC-2A, 6-32, length 3/4-inch.	
9	4	Washer, flat-round, steel cadmium plated, id .156 inch.	
10	4	Washer, lock-spring, helical, steel cadmium plated, #6.	
11	4	Nut, plain-hex, machine, steel cadmium plated, J NC-2B, #6-32.	
12	2	Screw, machine, slotted, steel cadmium plated, U NC-2A, 8-32, length 1/2-inch.	
13	2	Washer, flat round, steel cadmium plated, id .188 inch.	
14	2	Washer, lock-spring, helical, steel cadmium plated, #8.	
15	2	Nut, plain-hex, machine, steel cadmium plated, U NC-2B, #8-32.	
16	2	Screws, sheet metal, #8-32.	
17	4	Terminal lug, ring tongue, stud size 8, terminal size 14.	

(EIB 912)

t. Silver Plated Components Used in High Power Transmitters--Repair of

In lieu of having pitted and burned silver plated contacts and components replated by a commercial firm, Navy personnel can locally clean and replate on site, thus effecting a cost saving in maintenance funds and possible extended down time on equipment.

Components requiring cleaning and/or replating can be removed from equipment and disassembled as though they were going to be sent out to a commercial firm for replating. Each part requiring cleaning and/or replating can be cleaned by brushing with "Tarn-X" compound and then cleaned in an ultrasonic cleaner using the normal cleaning agents. After cleaning, the components should be thoroughly rinsed and brushed a second time with the "Tarn-X" compound, rinsed again and cool air dried. Any burned areas should be removed with a fine sand paper or wire brush.

Replating is accomplished by applying "Cool Amp" powder with a damp rag or small stiff brush, depositing a silver plate on the component by lightly rubbing the area to be plated.

Materials required for this process:

- a. TARN-X, JELMAR CO. One Illinois Center Suite 2820 Merchandise Mart, Chicago, IL 60654, \$14.50 per gallon - 4 gal. minimum.
- b. COOL AMP Silver Plate Powder, COOL AMP CO., 8603 175th Ave., S.W., Portland, OR 97219, \$23.25 plus postage per pound.

This procedure may not be successful in cases of extremely severe burned or pitted components where the metallic surface has been badly damaged. (EIB 944)

. Low Level Teletype Equipment-- General Information

The purpose of this article is to insure that the Electrical Service Assembly (ESA) and wiring are packaged together with the low level teletype equipment whenever either item is shipped for any reason such as:

- (1) A Surplus Item
- (2) Overhaul/Repair
- (3) A Direct Turn in Item

Since the (ESA) is a component part of the low level teletype equipment, the two items are listed together as a single unit under one National Stock Number (NSN). Therefore, when either item is shipped, both items must be kept together to prevent the repurchasing

of the item that is missing (the item not shipped).

Some of the equipments involved are:

TT-570/UG
TT-571/UG
TT-603/UG
TT-605/UG
AN/UGC-77
AN/UGR-9

(EIB 947)

. Teletypewriter Clutch Shoe Lever Clearance--Information Concerning

It has come to the attention of this command that various activities have been making the adjustment of the teletype clutch shoe levers improperly. The gap between the clutch shoe lever and its stop lug should be 0.055 inch to 0.085 inch greater when the clutch is engaged than when the clutch is disengaged. For a one hundred words per minute machine, the gap between the clutch shoe lever and its stop lug should be 0.070 inch to 0.075 inch greater when the clutch is engaged than when the clutch is disengaged.

The procedure for making clutch shoe lever gap check is as follows. Trip the clutch and rotate it until the clutch shoe lever is toward the bottom of the unit. Align the head of the clutch drum mounting screw with the stop lug. Manually compress the shoe lever against the stop lug and allow it to snap apart. Measure the gap with the clutch, thus engaged, and note the reading. Disengage the clutch and measure the gap. Subtract the second reading from the first reading. The difference between the two readings is the clearance requirement for the clutch shoe lever.

(EIB 951)

w. Information on Bonding to Meet TEMPEST-Related Installation Criteria

The purpose of this article is to provide a tabulation of national stock numbers and prices (estimated) for various bond straps and bonding hardware, and additional information concerning Tempist-related bonding requirements.

For Tempest-related purposes, bond straps are required only on resilient mounted equipment, slide foundations, cryptographic and cryptographic ancillary equipment, and power line filters. The resilient mounted equipment, frequently called shock-mounted equipment, and slide foundations do not have an RF bond metal-to-metal contact between the equipment itself and its supporting foundation, and therefore needs a bond strap. Cryptographic and cryptographic ancillary equipment is that equipment with a type designation having a suffix or prefix of "TSEC." Power line filters, because of their construction, require bond straps. Other equipment may use the metal-to metal contact inherent in the mounting hardware, provided that paint, grease, lacquer and other resistive materials are removed from the surface contact area prior to mounting, that all available mounting holes are used, and that the diameter of the mounting bolts, nuts and washers conform to the existing mounting holes.

What is a good bond to ground? Why not use the safety ground wire if it exists? The definition for bonding used in Tempest-related installation criteria is short and to the point. "The process of physically providing a positive, direct and continuous, metallic, low impedance d.c. to RF path between conducting materials."

Each word in that definition is important, but probably the most important are the "low impedance d.c. to RF path." This means the minimum possible impedance is required throughout the frequency spectrum from 0 Hz into the radio frequencies. For a bond strap to meet this requirement, it must have certain minimum dimensions such as those specified in the detailed bonding requirement paragraphs of MIL-STD-1680. The conductor in a power cable used for safety (3rd wire ground) cannot qualify as a bond. The length of the cable from the equipment to the power distribution panel where the safety conductor is connected to ground may be 15, 20 or 25 feet in length. Any conductor this long is not a low impedance d.c. to RF path.

The flexible bond strap is intended for those equipments that necessarily must be moved in the course of normal operations, such as to gain access for teletype paper replenishment, or for changing switch settings. The most common usage is on the slide foundation in an equipment cabinet. Using the material listed below, the bond strap should not exceed 12 inches in length (some installations may require as much as 14 inches), but should always be as short as practicable.

<u>Item</u>	<u>Unit of Issue</u>	<u>Price</u>	<u>NSN</u>
Flat braided wire (1-inch, 352 wires, 36 AWG uncoated copper)	foot	25¢	9I-6145-00-669-5552 (The NSN listed in MIL-STD-1680, para. 5.1.13.3 is incorrect)
Tube, metallic (0.840-inch diameter)	foot	92¢	9C-4710-00-277-4023

The solid bond strap shall not be longer than 8 inches and not less than 3/4-inch in width (the length-to-width ratio shall not exceed five-to-one). The thickness of the flat copper shall not be less than 0.020-inch. National stock numbers for common lengths of

solid bond straps are tabulated below. Solid bond straps in excess of 5 inches are not available in the supply system and must be fabricated locally.

<u>Item</u>	<u>Unit of Issue</u>	<u>Price</u>	<u>NSN</u>
Bus, conductor (length 2", cadmium plated bond strap)	each	26¢	9G-6150-01-016-4648
Bus, conductor (length 3", cadmium plated bond strap)	each	27¢	9G-6150-01-016-5289
Bus, conductor (length 4", cadmium plated bond strap)	each	29¢	9G-6150-01-016-5288
Ground strap (length 5", cadmium plated bond strap)	each	44¢	9G-5940-00-025-9083

A minimum of 5/16-inch hardware is required in order to provide sufficient electrical bonding contact area. The split-lock and flat washers of 5/16-inch hardware provide this bonding contact area. Hardware of lesser dimensions will not. Commonly used hardware that is available in the supply system is listed below:

<u>Item</u>	<u>Unit of Issue</u>	<u>Price</u>	<u>NSN</u>
Screw, cap, hex (5/16-inch dia, length 1", cadmium plated)	each	9¢	9Z-5305-00-753-4322
Screw, cap, hex (5/16-inch dia, length 1-1/4", cadmium plated)	each	3¢	9Z-5305-00-225-9081
Washer, lock, 5/16-inch	100	50¢	9Z-5310-00-407-9566
Washer, flat, 5/16-inch	100	78¢	9Z-5310-00-809-3078
Nut, plain, hex, 5/16-inch	each	20¢	9Z-5310-00-829-9981

The bond strap loses its effectiveness unless grease, paint, lacquer, dirt and other resistive materials are removed from the area where the bonding strap is connected to the equipment or the foundation (bonding contact area) prior to mounting.

Bond straps had previously been required on many other equipments in the Tempest environment. These requirements have been considerably reduced. Therefore many bond straps may exist on equipment that no longer require them. Such a case may exist for rack-mounted or non-resilient mounted equipment. However, during initial installation of this equipment, the surface contact area surrounding the mounting hardware may not have been properly prepared for a good bond, in that the bond strap was being used for this purpose. If this surface contact area surrounding the mounting hardware is properly cleaned of paint, dirt and other resistive materials, the bond straps are no longer required. Retaining these bond straps certainly does no harm, if they are maintained in good condition. But frequently these bond straps fall into disrepair, are not connected at one end, or have an abundance of paint or other resistive materials between the bonding surfaces. If the bond strap falls into disrepair, and it is not required, it might be well to remove the bond strap, provided the surface contact area of the mounting hardware is properly cleaned.

(EIB 957)

1. The first part of the document discusses the importance of maintaining accurate records of all transactions.

2. It is essential to ensure that all entries are supported by appropriate documentation.

3. The second part of the document outlines the procedures for reconciling bank statements.

4. This process involves comparing the company's records with the bank's records.

5. It is important to identify and investigate any discrepancies as soon as they are discovered.

6. The final part of the document provides a summary of the key points discussed.

7. In conclusion, maintaining accurate records and reconciling bank statements are crucial for the financial health of any organization.