

37 KEYBOARD SEND-RECEIVE (KSR) TELETYPEWRITER SET AND 37 AUTOMATIC  
SEND-RECEIVE (ASR) TELETYPEWRITER SET FOR "DATA-PHONE®" SERVICE

GENERAL DESCRIPTION AND OPERATION

CONTENTS	PAGE	CONTENTS	PAGE
1. GENERAL . . . . .	2	CHANNEL INTERFACE . . . . .	19
2. DESCRIPTION . . . . .	3	ORIGINATING AND ANSWERING . . . . .	19
STANDARD FEATURES . . . . .	3	LOCAL OPERATION . . . . .	19
VARIABLE FEATURES . . . . .	3	A. Device Selection . . . . .	19
KEYBOARD SEND-RECEIVE UNIT COMPONENTS . . . . .	5	B. Motor Control . . . . .	19
A. Typing Unit . . . . .	5	C. Message Exchange . . . . .	21
B. Keyboard . . . . .	6	LINE OPERATION . . . . .	21
C. Base . . . . .	6	A. Device Selection . . . . .	21
D. Control Panel . . . . .	6	B. Channel Establishment . . . . .	22
E. Motor Unit . . . . .	6	C. Message Exchange . . . . .	22
F. Typing Unit Cover and Pan . . . . .	10	SIMULTANEOUS LOCAL-LINE OPERATION . . . . .	22
G. Table . . . . .	10	CHANNEL TERMINATION . . . . .	22
H. Electrical Service Unit . . . . .	10	5. REFERENCES . . . . .	22
I. Data and Attendant Set . . . . .	11		
RT MODULE COMPONENTS . . . . .	11		
A. Reperforator Unit . . . . .	11		
B. Reader Unit . . . . .	12		
C. Electrical Service Unit . . . . .	13		
D. Motor Units . . . . .	13		
E. RT Module Cabinet . . . . .	13		
ACCESSORIES . . . . .	13		
A. Answer-Back Assembly . . . . .	13		
B. Paper Handling Accessories . . . . .	13		
C. Tape Handling Accessories . . . . .	13		
3. TECHNICAL DATA . . . . .	13		
4. OPERATION . . . . .	16		
GENERAL . . . . .	16		
PERIPHERAL INTERFACE . . . . .	16		

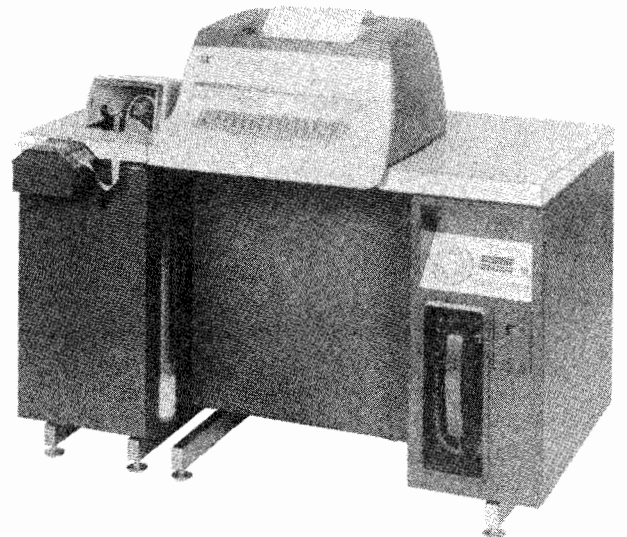
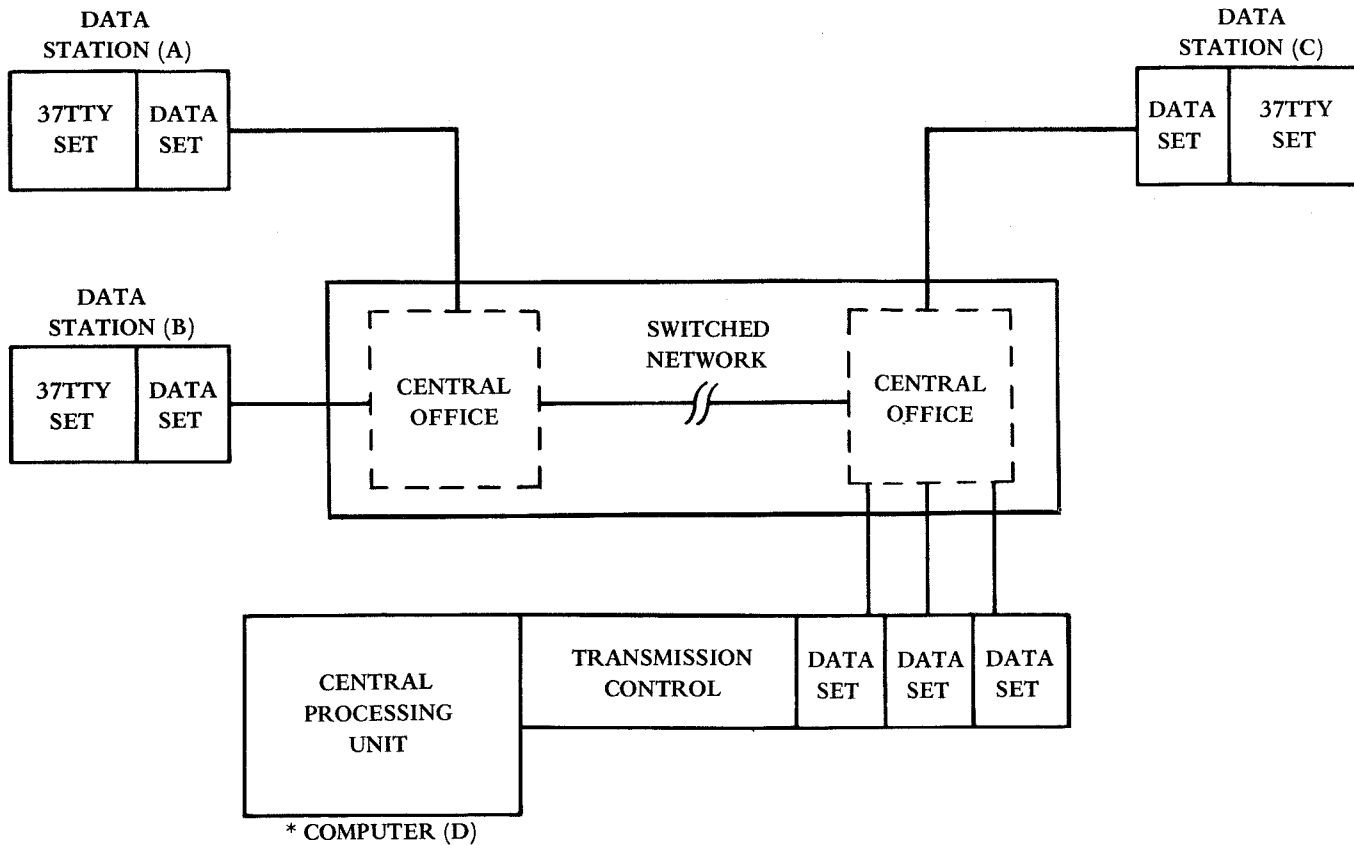

Figure 1 - 37 ASR Teletypewriter Set



\* Customer - provided

Figure 2 - Switched Network Application Using 37 Teletypewriter Equipment

## 1. GENERAL

1.01 This section provides a general description and operation of 37 Keyboard Send-Receive (KSR) and 37 Automatic Send-Receive (ASR) Teletypewriter (TTY) Sets which are used in switched network service (Figure 1).

1.02 A 37 ASR or KSR TTY Set is a heavy-duty terminal that functions with the ASCII (American National Standard Code for Information Interchange) and has EIA (Electronics Industries Association) Standard RS-232-B interfacing. The sets operate at a speed of 150 words per minute (wpm).

1.03 The styling and equipment are designed to complement modern office furnishings. The operator interface including keyboard layout and touch, quality of printed copy and equipment noise is comparable to that of an office typewriter. The equipment has a modular design which permits rapid conversion from one type of set to another.

1.04 References to left or right, front or rear, top or bottom, etc, apply to the set in its normal position as viewed by the operator.

1.05 The 37 KSR TTY Set originates data through its keyboard and the ASR TTY set originates data through its keyboard or tape reader in the form of voltage signals, ie, positive (+) voltage for spacing signals and negative (-) voltage for marking signals. These voltages are converted into voice frequency tones by a data set for transmission over communication lines. Received data, in the form of voice frequency tones, is converted into voltage signals by a data set. The voltage signals are used by the 37 KSR Set to copy the data on page size copy paper or business forms and by the 37 ASR Set to copy the data on page size copy paper or business forms and/or fully perforated tape.

1.06 Figure 2 is a block diagram illustrating the use of 37 TTY equipment in a switched network application. It should help in understanding the overall capabilities of a 37 TTY set.

1.07 Data station A may call station B and transmit and/or receive data through their common central office. Station A may exchange data with station C using the switched network facilities between the two central offices.

1.08 A 37 TTY data station may be used to communicate with a customer-provided time-shared computer D. In a switched network application, station A may call the computer. When the computer answers the call, station A and the computer may exchange data.

1.09 Conversely, each data station is equipped to receive calls from the computer through the switched network system. This permits the computer to call any of the data stations and transmit or request data.

1.10 References made to features, descriptions, or operations of the 37 TTY sets are assumed to be common to both the KSR and the ASR sets unless stated otherwise.

## 2. DESCRIPTION

2.01 A typical KSR TTY set (Figure 3) consists of the components listed under **KEYBOARD SEND-RECEIVE UNIT COMPONENTS**. The ASR TTY set consists of the KSR components, plus the components listed under **RT MODULE COMPONENTS**.

### STANDARD FEATURES

2.02 The following features are standard on KSR sets:

- Modern modular design.
- Interfacing which conforms with EIA Standard RS-232-B.
- Sends and receives at the speed of 150 wpm (15 characters a second) with a 10-unit code transmission pattern.
- Generates all 128 ASCII characters with even parity.
- Receives all 128 ASCII characters – prints 94 graphics including upper and lower case alphabet.
- Seventy-two characters on a line (10 per inch). Craftsman adjustable for shorter or longer lengths up to 80 characters.
- End of printed line indication (lamp) which is craftsman adjustable.
- On-line backspace.
- On-line carriage return and line feed.

- Local carriage return.
- Local paper feed-out.
- Single color printing.
- Operator control of multiple copy.
- Operator control of vertical spacing.
  - (a) 3 lines per inch.
  - (b) 6 lines per inch.
- Roll paper (friction feed sets) or flat-folded, form-feed paper with marginal perforations (sprocket feed sets).
- Print position indicator (next character indicator).
- Print position scale.

2.03 The standard features on the ASR sets include all the standard features listed above for the KSR sets, plus the following features:

- Local reader character advance.
- Low-tape alarm (lamps).
- Send on-line through keyboard or tape reader.
- Receives through typing unit or reperforator unit.
- Local reperforator backspace.

### VARIABLE FEATURES

2.04 In addition to the above standard features, certain options and accessories can be obtained which provide the following variable features:

- Two-color ribbon.
- Printed graphics extension.
- Horizontal tabulation on-line control.
- Vertical tabulation on-line control.
- Half-forward, Half-reverse, and reverse line feed.
- Nonrepeat form feed.
- Carriage return on receipt of NEW LINE, VT, or FF characters.
- Optional operating speed of 100 wpm (10 characters a second) with an 11-unit code transmission pattern.

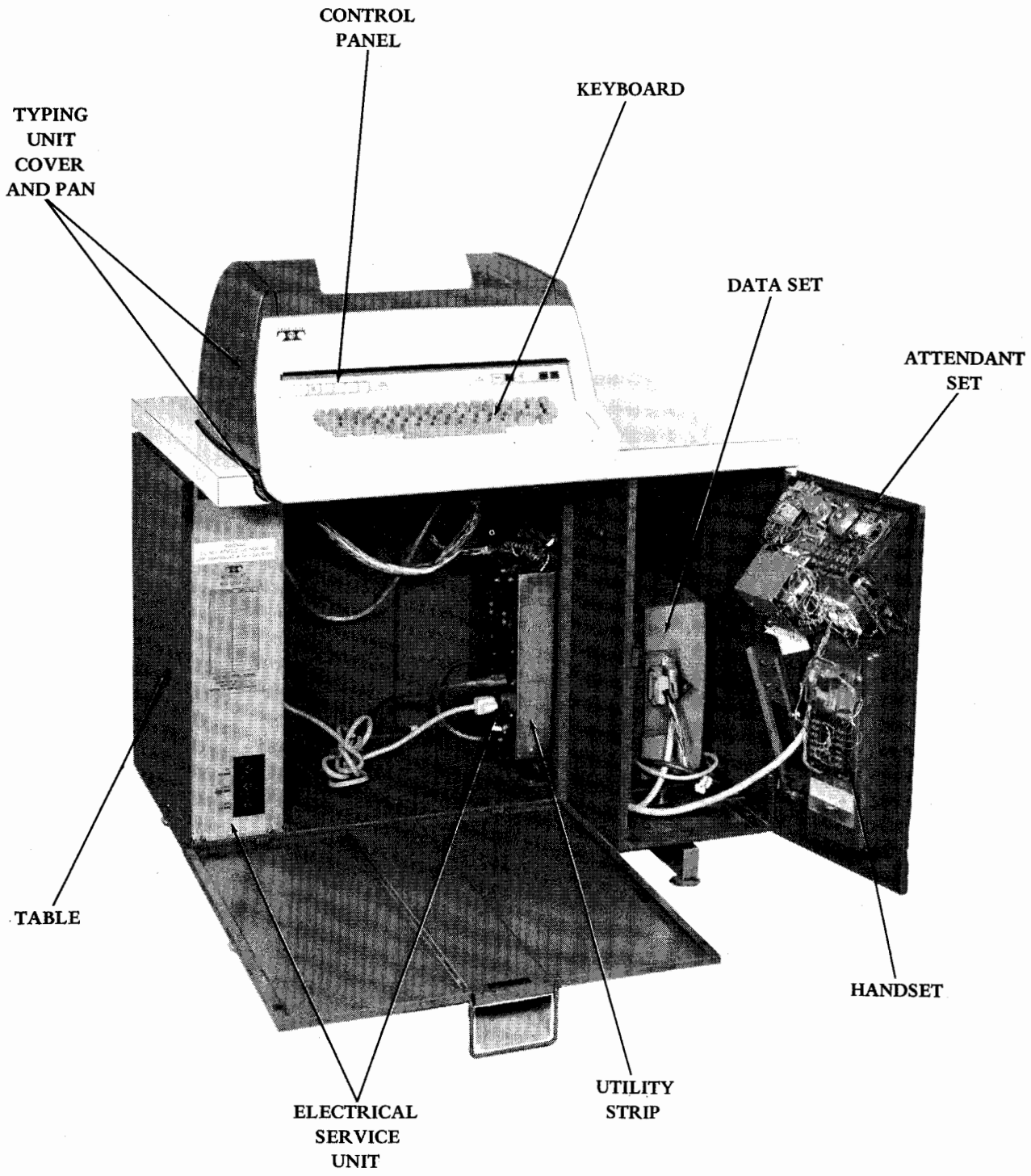

(Left Front View)

Figure 3 - 37 KSR Teletypewriter Set (Components)

- Optional dedicated half-duplex, dedicated full-duplex, or line control of home copy.
- Optional power tape handling winder or winder-unwinders (ASR only).
- Optional tape storage bin (ASR only).
- Front or rear loading of forms.
- Answer-back triggered either automatically from data set, upon receipt of ENQ character, or manually with HERE IS pushbutton.
- Keyboard and reader transmission blinded on NAK character, unblinded on ACK character.
- Disconnect capability on EOT character.
- Incorrect vertical parity indication.
- Character repeat feature – craftsman adjustable.

**Note:** This feature is normally disabled on all keys except the following:

Space	Period (.)
NEW LINE	Hyphen (-), Equal (=)
BACKSPACE	Underscore (_)
NULL	Colon (:), Asterisk (*)
DELETE	Character X

- Alarm indication for low-paper (friction feed sets) or paper-out condition (sprocket feed sets).
- Form advance (form-out).
- Vertical tabulation (craftsman adjustable).
- Horizontal tabulation (craftsman adjustable).
- Eighty-six characters on a line (12 per inch).

#### KEYBOARD SEND-RECEIVE UNIT COMPONENTS

##### A. Typing Unit

2.05 The typing unit (Figure 4) receives information serially by means of a single magnet (two coils) type of selector. A function box is provided for character and character sequence recognition.

2.06 Page copy is provided by the typing unit which prints both upper and lower case characters utilizing a typebox positioned by an aggregate motion mechanism. The typebox is moved from character to character and

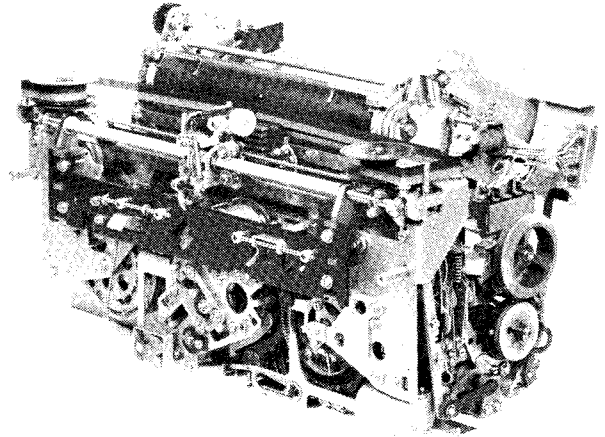

Figure 4 - Typing Unit

is returned to “home” position when reception stops, thus, making all characters visible when the machine is idle.

2.07 The typing unit is capable of printing symbols for all 128 ASCII characters. Normally, however, it will be arranged to print the 94 graphic, numeric, and alpha characters of ASCII.

2.08 Normally the typing unit will print ten characters per inch allowing 72 characters on an 8-1/2 inch platen with normal margins on the paper. Optionally, other typing units may be arranged to print 12 characters per inch allowing 86 characters on an 8-1/2 inch platen with normal margins on the paper. Line feed provides for spacing six lines of type per vertical inch.

2.09 Two types of paper feed options are available:

(a) A typing unit arranged for friction feed is capable of accommodating roll paper widths of 3 to 8-1/2 inches and capable of providing multiple copies of one original and two carbons.

(b) A typing unit arranged with sprocket feed is capable of handling sprocket feed paper 11 inches long and 9-1/2 inches wide. One-half inch is needed on each side of a page to allow for sprocket holes. The typing unit is capable of providing multiple copies consisting of one original and up to five carbons.

2.10 All typing units are equipped with line feed and carriage return (both on-line and local), on-line backspace, and craftsman adjustable margins.

2.11 Optional paper positioning controls are provided for either friction feed or sprocket feed typing units:

- (a) Form-Feed – When the typing unit detects the form-feed character, it will position the paper for printing on the first line of the next page. Pages up to 15 inches in length, adjustable by a craftsman, may be accommodated. The typing unit form feeds three lines during one character interval. Two successive form feeds are prevented unless there has been an intervening line feed.
- (b) Horizontal Tabulation – This feature is a fixed tabulator stop type. The fixed stops are set by a craftsman to customer specifications.
- (c) Vertical Tabulation – This feature is a fixed tabulator stop type. The fixed stops are set by a craftsman to customer specifications.
- (d) Horizontal Tabulation On-Line Control – This is an on-line feature used to set and clear tabulation stops in the typing unit horizontal tabulation mechanism. The characters ESC 1 are used to set tabulator stops and the characters ESC 2 are used to clear the stops.
- (e) Vertical Tabulation On-Line Control – This is an on-line feature used to set and clear the tabulation stops in the typing unit vertical tabulation mechanism. The characters ESC 5 are used to set the tabulator stops and the characters ESC 6 are used to clear the stops.

## B. Keyboard

2.12 A standard 4-row keyboard configuration (Figure 5) is used. The keytop arrangement is consistent with a standard office typewriter (Figure 6).

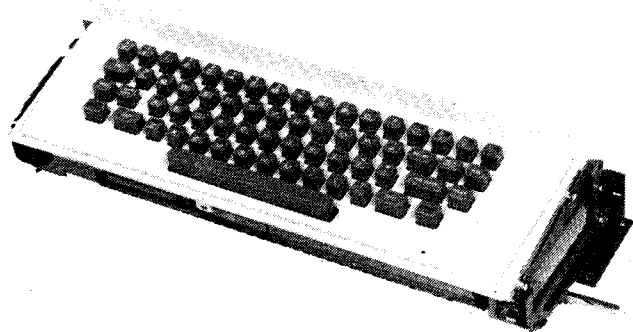

Figure 5 - Keyboard

2.13 The keyboard is an electromechanical device for generating ASCII combinations. It converts the mechanical depression of a key into electrical code patterns. Keys move codebars which control electrical contacts. The electrical contacts present an even vertical parity parallel wire output to a keyboard control logic card in the electrical service unit which converts the signals into ASCII.

2.14 It is possible to generate all 128 code combinations of ASCII. Upper and lower case alpha characters, numerics, and special graphic characters are designated on the keytops. Control characters are designated on the keyboard in two ways. The most often used controls appear on separate keys and are active in both the shifted and unshifted modes without use of the CONTRL key. Another group of controls appear on the same keytop with a graphic. To generate these code combinations, it is necessary to depress the CONTRL key while the particular key is struck. All control character designations requiring the depression of the CONTRL key, as well as the individual key, appear on the keyboard in charcoal grey.

2.15 A repeat feature is provided on each key generating a character. Further depression of the key beyond its normal stop position causes the associated character to be generated repetitively at the maximum character rate. The repeat feature is enabled or disabled by a craftsman.

2.16 A transmission disable feature is provided to prevent transmission from the keyboard or reader. Transmission may be disabled and enabled under control of on-line signals as covered in 4.10 and 4.30. This feature does not physically lock the keys of the keyboard but inhibits output from the transmitter distributor.

## C. Base

2.17 The base provides mounting facilities for the typing unit, motor unit, and intermediate gear assembly. Holes are also provided on the base for mounting the keyboard reset mechanism and margin indicator switch.

## D. Control Panel

2.18 The control panel (Figure 7) which is located above the keyboard contains a number of nonlocking pushbuttons. In addition, there are two mechanical pushbuttons designated PAPER ADVANCE and LOCAL RETURN. The two different arrangements available to meet varying applications are shown in Figure 7. Functional descriptions of the different controls are given in Table A.

## E. Motor Unit

2.19 The function of the motor is to provide electro-mechanical rotating motion for operating the typing unit and keyboard reset mechanism.

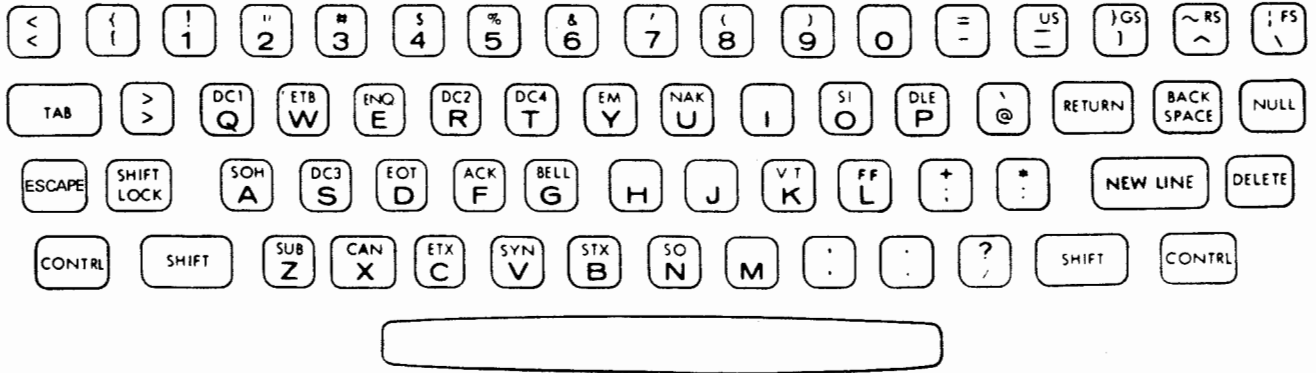
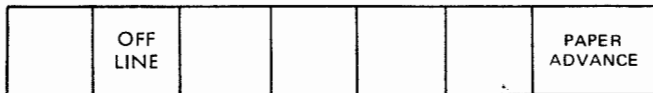
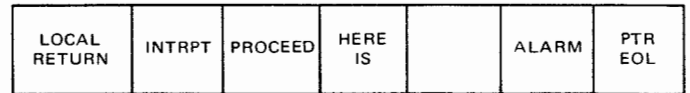

Figure 6 - Keyboard Arrangement

ARRANGEMENT 1 - KSR



(Left-Side Pushbuttons)



(Right-Side Pushbuttons)

ARRANGEMENT 2 - ASR

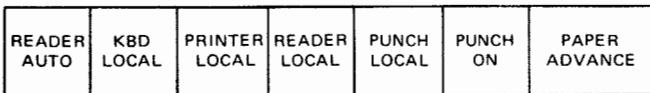

(Left-Side Pushbuttons)

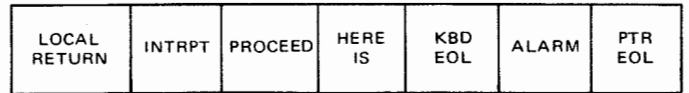

(Right-Side Pushbuttons)

Figure 7 - Typical Control Panel Arrangements

TABLE A  
CONTROLS DESCRIPTION

CONTROL (Figure 7)	FUNCTION
OFF LINE	Depressing this pushbutton lights the associated indicator and activates the teletypewriter for use in the off-line (local) mode. A second operation of the pushbutton extinguishes the light and conditions the equipment for incoming and outgoing calls. If this pushbutton is depressed while a data call is in progress, a disconnect will result.
PAPER ADVANCE	Paper is fed out of the typing unit for as long as this pushbutton is held depressed. This is a local function only, and has no effect on the distant station.
LOCAL RETURN	When this pushbutton is depressed, the typing unit carriage returns to the left margin. This is a local function only, and has no effect on the distant station.
INTRPT (interrupt)	When momentarily depressed, this pushbutton causes a timed (380 to 750 millisecond) spacing signal (break) to be sent on-line. It is used by the receiving station to interrupt transmission from the sending station.
PROCEED	This lamp lights when the station is ready for sending from the keyboard. (It will light when the unlighted pushbutton is depressed, or when an ACK character is received, and will turn off when a NAK character or interrupt signal is received.) Either the receipt of an ACK character or manual operation of the PROCEED pushbutton will relight the lamp. The lamp turns off when a data call is completed.
HERE IS	When momentarily depressed, this pushbutton starts the local answer-back mechanism which causes a stored series of characters (such as station identification) to be sent. The answer-back only operates on-line.
ALARM	When lighted, this lamp may indicate a low-paper supply condition. The ALARM lamp also optionally lights when a character is received with incorrect vertical parity. The lamp will be turned off by depressing the ALARM pushbutton if a parity error was received. When lighted by a low-paper condition, the lamp turns off only after the paper supply is replenished.
EOL (Printer End of Line)	This lamp lights to indicate the end of a printed line (adjustable for any length of line suitable to the typing unit). The light goes off when a new line is started.



TABLE A  
CONTROLS DESCRIPTION (Continued)

CONTROL (Figure 7)	FUNCTION
READER AUTO	When this pushbutton is depressed, the associated lamp lights, and the station is conditioned for auto control of the reader by the characters DC1 and DC3. When the pushbutton is depressed again, the light goes out and the auto reader control feature is disabled (both the reader and typing unit must be on-line).
KBD LOCAL	When this pushbutton is depressed, the associated lamp lights, the typing unit motor starts, and the keyboard is placed in the off-line (local) mode.
PRINTER LOCAL	When this pushbutton is depressed, the associated lamp lights, the typing unit motor starts, and the typing unit is placed in the off-line (local) mode. When the pushbutton is depressed again, the typing unit is placed in the on-line mode.
READER LOCAL	When this pushbutton is depressed, the associated lamp lights, the reader motor is started, and the reader is placed in the off-line (local) mode. When the pushbutton is depressed again, the lamp goes out, the motor stops, and the reader is placed in the on-line mode.
PUNCH LOCAL	When this pushbutton is depressed, the associated lamp lights and the reperforator (punch) is placed in the off-line (local) mode. The punch selector may be blinded or not depending on the state of the PUNCH ON pushbutton. Depressing the pushbutton again turns off the light and restores the reperforator to the idle condition.
PUNCH ON	When this pushbutton is depressed, the associated lamp lights and the reperforator selector is unblinded. Depressing the pushbutton again turns the lamp off and causes the reperforator selector to be blinded. For local operation of the reperforator, the PUNCH ON pushbutton must be depressed after PUNCH LOCAL is depressed.
KBD EOL (Keyboard End of Line)	This lamp is lighted by a character counter and indicates that sufficient characters have been perforated in tape to produce a line of characters on page copy. The counter counts down on backspace and is reset on carriage return.

2.20 The motor is a synchronous-type, rated at 1/20 horsepower, and is operated from a 117 volt  $\pm 10\%$  ac, single phase, 60 hertz  $\pm 0.45$  Hz source of commercial power. It consists of a 2-pole wound stator with two windings (a main running winding and a start winding), and a ball bearing rotor. The start winding is in series with a start relay, capacitor, and thermal cutout switch which are mounted in a compartment of the motor mounting cradle.

F. Typing Unit Cover and Pan

2.21 The typing unit cover and pan includes copylights and provides the housing for the typing unit, keyboard and base, motor, and control panel. The cover and pan with assembled components normally mount onto a table.

2.22 The cover is hinged to the pan and can be easily removed, or it may be raised and extended over interior components while maintenance is being performed.

2.23 Two lids at the top of the cover provide access to the typing unit for ribbon changing, replenishing paper supply, adjusting print hammer for multiple copy, etc.

G. Table

2.24 The table provides a mounting surface for the typing unit cover and pan and the other components which the cover and pan houses. In addition, a compartment of the table provides facilities for mounting the electrical service unit including the utility strip. The ac power for the set components is obtained from the utility strip when its ac power cord is plugged into a commercial source of power.

2.25 Three optionally available tables may be obtained: A double-compartment table and two single-compartment tables which differ primarily in overall depth dimension (Figure 15).

H. Electrical Service Unit

2.26 The electrical service unit (Figure 8) consists of a chassis assembly and a utility strip which mount into the lower part of the knee well of the table. The chassis assembly has a multivoltage power supply, a wiring field, and is equipped with eleven card connectors. A set of circuit cards selected for a given arrangement provides the set logic (Table B). The cards mount into the card connectors.

2.27 Wiring from the card connectors terminates at the wiring field which provides a centralized wiring location for the set. Cable assemblies with several plugs also terminate at the wiring field. The plugs connect to the typing unit, keyboard and base, control panel, copylights, etc. An interface connector provides a signal interchange point which conforms with the EIA-232-B Standard.

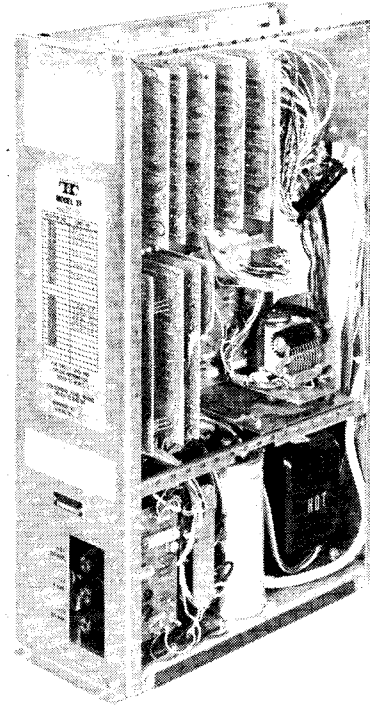

Figure 8 - Electrical Service Unit

TABLE B  
CIRCUIT CARDS

Cards in Keyboard Send-Receive Unit	Quantity	
	KSR	ASR
Mode Control	1	1
Receive Device Control	1	1
Receive Control	1	1
Alarms (or alarms and automatic control)	1	1
Keyboard Control	1	1
Distributor	1	2
Character Counter		1
Send Control	1	1
Channel Control	1	1
Cards in RT Module	Quantity	
Receive Device Control		1
Reader Driver		1

2.28 A power cord from the chassis assembly plugs into one of the six ac power receptacles of the utility strip. The ac power for the set is provided over a single ac power cord which terminates at one of the two utility strip terminal boards, and is controlled by a circuit breaker.

2.29 A bell assembly, copylight transformer, and motor control relay are also a part of the utility strip and derive their power from the multivoltage power supply in the chassis through a second utility strip terminal board.

2.30 The multivoltage power supply converts ac power into appropriate dc power which is used for internal set operation, ie, the regulator, solenoids, lamp driver amplifiers, motor control relay, bell, integrated and discrete semiconductor circuits, etc.

#### I. Data and Attendant Set

2.31 The standard data set for 37 TTY DATA-PHONE service is Data Set 103H (Figure 9). This data set is a general purpose, full-duplex, frequency shift keyed, serial data transmission set that accepts voltage signals from the teletypewriter logic, and converts these signals into voice frequency tones. These tones are transmitted over the telephone transmission facilities to the distant terminal, where a compatible data set converts the voice frequency tones into voltage signals.

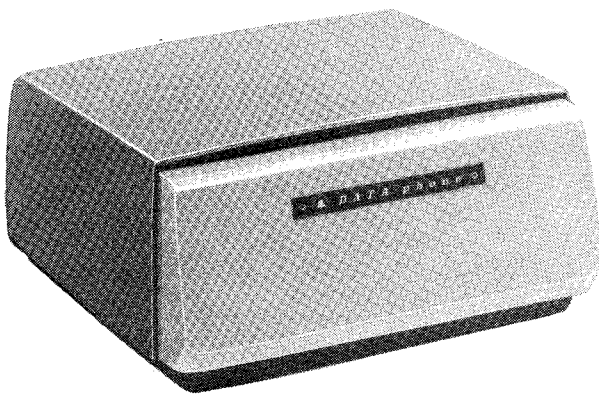

Figure 9 - Data Set 103H

2.32 The Data Auxiliary Set DAS804P-type (Figure 10) is available with the following dialing features:

- (a) Rotary dial
- (b) "TOUCH-TONE®" dial
- (c) Rotary and card dialer
- (d) TOUCH-TONE and card dialer

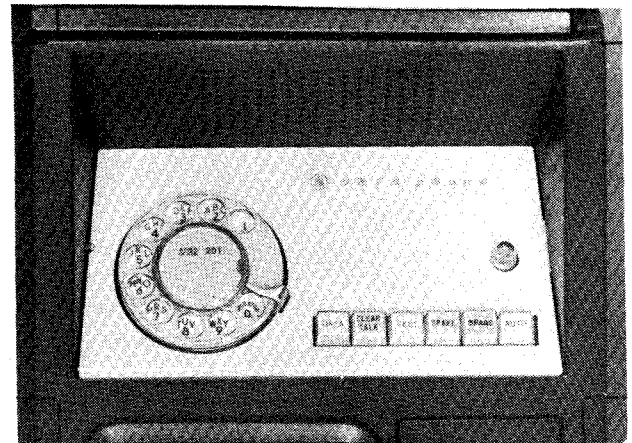

Figure 10 - Attendant Set Controls (Rotary Dialer)  
(DAS 804P5)

Each type has associated with it a hand telephone set, a loudspeaker, amplifier, loudspeaker control, ringer, and a set of combination pushbutton indicators (Table C). The pushbutton indicators are used to control calls, or test the data set.

#### RT MODULE COMPONENTS

##### A. Reperforator Unit

2.33 The reperforator unit (Figure 11) is an electro-mechanical device that converts data received serially into corresponding perforations in tape. It uses a single magnet selector similar to that used in the typing unit (2.05).

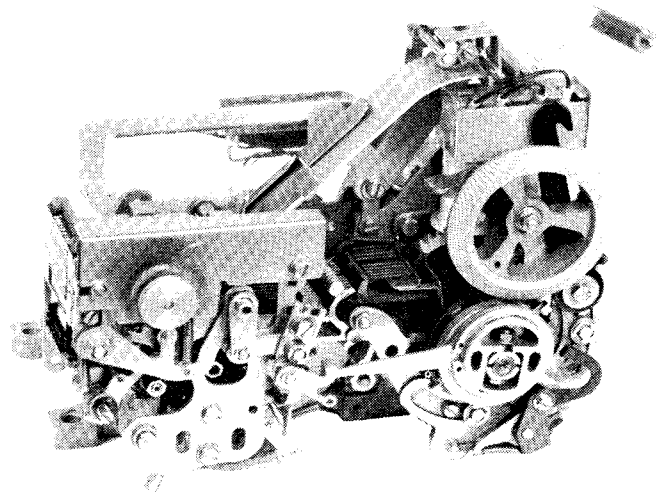

Figure 11 - Reperforator Unit

**TABLE C**  
**ATTENDANT SET CONTROLS**

CONTROL (Figure 10)	FUNCTION
DATA	When this pushbutton is depressed, the associated lamp lights indicating that the station is in the data mode. In this condition, the telephone mode will not operate (even if the handset is not on the switch hook).
CLEAR/TALK	When depressed, this pushbutton clears (disconnects) a data call. The associated lamp lights for the duration of the clearing cycle. The station disconnects after the data portion of the call is cleared unless the handset is off its switch hook, in which case the call is placed in the telephone mode. This pushbutton (when depressed) also stops any actions initiated by a previously depressed DATA or TEST pushbutton, and turns off their associated lamp.
TEST	When this pushbutton is depressed, the associated lamp lights and the data set is conditioned for remote testing from a data test center.
AUTO	This pushbutton operates independently from the other pushbuttons. When the pushbutton is depressed, the associated lamp lights and the station is placed in condition for automatic answering. The AUTO answer mode is effective only when the station is ready to receive a call; for example, when paper supply is adequate.
LOUDSPEAKER	Call progress tones (dial tone, busy tone, etc.) are heard in this speaker when "hands free" calls are made.
VOLUME CONTROL	This control regulates speaker volume.

2.34 The unit is a nontyping reperforator that provides fully-perforated tape. It is equipped with a manual interfering tape feed-out mechanism to simplify tape loading. The reperforator unit also includes a power backspace mechanism. This device permits backspacing tape to eliminate erroneous data by overpunching with delete characters. A typing reperforator is optionally available.

#### B. Reader Unit

2.35 The reader unit (Figure 12) is an electromechanical device used to convert perforations in tape into corresponding parallel electrical data.

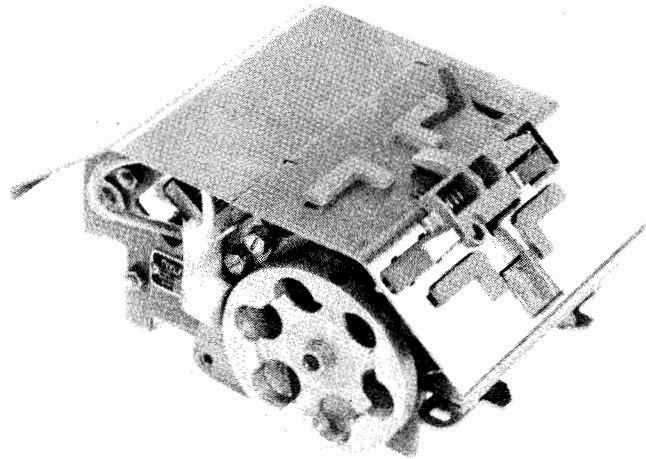

Figure 12 - Reader Unit

2.36 The reader is equipped with a manual control lever, tight-tape and tape-out alarm sensors, and the reader step feature. The control lever has three positions: RUN (operating position); STOP (off position); and FREE (tape threading position).

#### C. Electrical Service Unit

2.37 The electrical service unit used in the RT module contains a wiring field and circuit cards required to control the reperforator and the reader units (Table B), interconnecting control and power cables, and a control panel.

2.38 The control panel (Figure 13) provides six push-button and indicator lamp positions for operating the reperforator and reader units (Table D).

#### D. Motor Units

2.39 The RT module includes two motor units. One is used to drive the reperforator and is identical to the typing unit motor unit (2.19). The reader unit is driven by a synchronous-type motor developing 1/50 hp and operating at a speed of 1800 rpm.

#### E. RT Module Cabinet

2.40 The RT module cabinet provides mounting and operating facilities for the reperforator unit, reader unit, electrical service unit, motor units and bases. It includes a hinged cover with a clear window for access to the reperforator unit and tape supply container. A chad disposal tube is provided for holding punched chad.

2.41 A reader base is fastened to a mounting bracket in the cabinet with vibration mounts. A toothed belt and pulley are used in conjunction with the motor unit to drive the reader unit.

2.42 The cabinet includes a reperforator base and a mounting plate for installing the reperforator unit and motor unit. A tape supply container with an 8-inch diameter supply reel, a low-tape alarm switch, and connecting cable are included with the reperforator base.

2.43 The cabinet door encloses the electrical service unit compartment. The door may be optionally equipped with either one power tape winder or a combination of a winder and unwinder. A switch is provided on the door to control the tape winders (Figure 14).

### ACCESSORIES

#### A. Answer-Back Assembly

2.44 The answer-back assembly provides for automatically transmitting a maximum of 20 characters for set identification. The assembly consists of a mechanical mechanism, an electronic circuit, and a mounting arrangement.

2.45 The mechanical mechanism (answer-back unit) has a magnet assembly which, each time it is pulsed and released, moves a 20-character codeable drum. Contact wires ride tines of the drum. The electronic circuit (answer-back driver card) drives the magnet and provides read-out for the contacts.

#### B. Paper Handling Accessories

2.46 A number of paper handling accessories are available for sets with sprocket feed typing units. Modification kits are available for either front or rear loading of a standard box of paper forms. Front loading of forms can be used for forms up to 14 inches in length. Forms up to 15 inches long can be loaded from the rear of the table. A form accumulator is also available as an accessory if desired.

#### C. Tape Handling Accessories

2.47 The RT module may be equipped with a power winder or winder-unwinder combination (Figure 14). These devices operate at speeds of up to 1200 wpm and have a 1000 foot tape capacity. Separate control switches are provided. The single reel winder and the top of the dual winders is used for reader tape winding. The lower winder is used to wind tape from the reperforator. With both winders available, the lower winder can provide fast reel-to-reel rewinding or power unwinding from a message reel to the reader unit.

2.48 An optional 50 foot capacity tape storage bin and tape deflector is also available for use with the RT module.

### 3. TECHNICAL DATA

#### 3.01 Electrical and Environmental Characteristics

- (a) Power . . . . . 117 volts ac +10%, 60 Hz  
±0.45 Hz, 15 ampere fused  
circuits, single phase (3-wire)
- (b) Temperature ranges . . . . . This equipment is intended to be operated in a room environment within the temperature range of 40° F. to 110° F. Serious damage to it could result if this range is exceeded. In this connection, particular caution should be exercised in using acoustical or other enclosures.



RT Module Control Panel

CONTROL  
PANEL

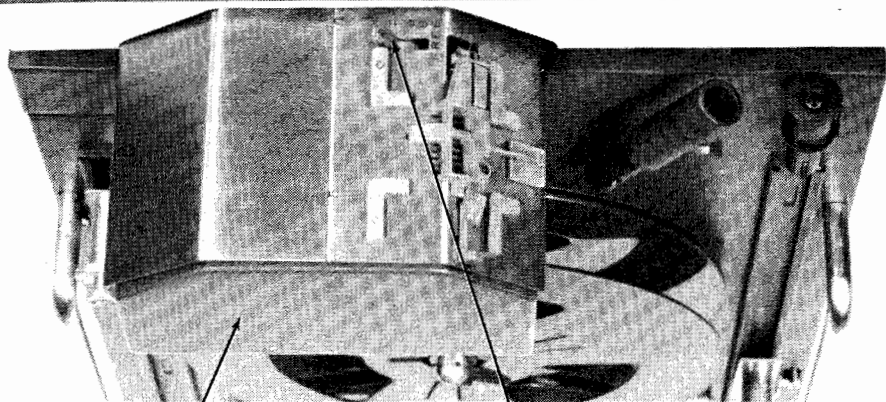
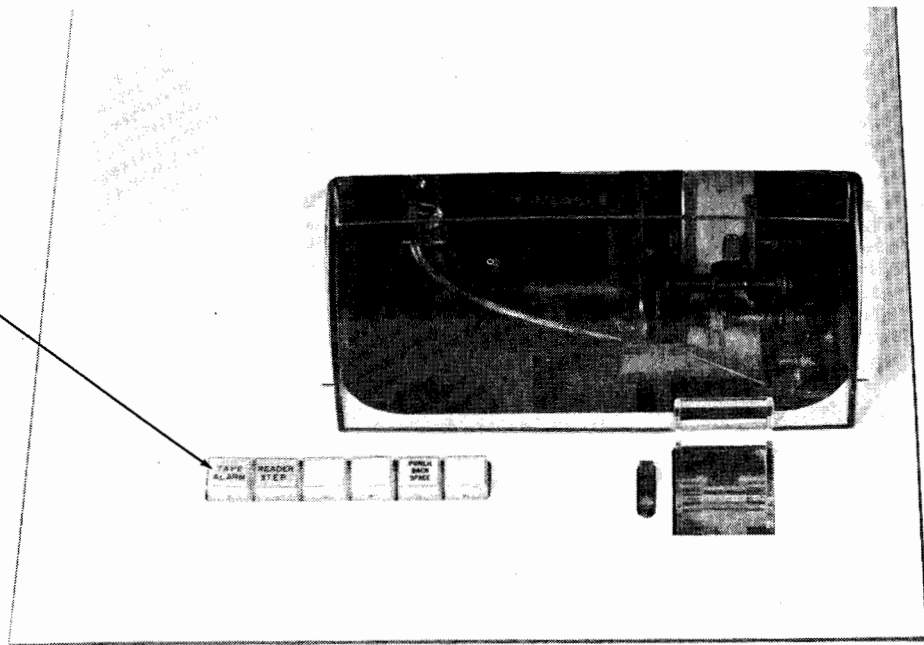

READER  
UNIT

CONTROL LEVER  
(RUN-STOP-FREE)

Figure 13 - RT Module Controls

TABLE D  
MODULE CONTROLS

CONTROL	DESCRIPTION
TAPE ALARM	This indicator lights whenever the tape in the reader is tight, twisted, bunched, or out; it will also light if the reperfocator tape is out, or if a tight-tape condition exists at the switch on the door.
READER STEP	This pushbutton advances the tape through the reader unit one character each time the pushbutton is depressed. The character read will be serialized and transmitted.
PUNCH BACKSPACE	This pushbutton backspaces the tape in the reperfocator one character each time the pushbutton is depressed.
RUN-STOP-FREE	This control lever on the reader unit permits normal operation of the unit in the RUN position and turn-off in the STOP position. In the FREE position, the feed wheel is free and tape may be pulled through the unit without opening the tape lid. When the automatic reader start feature is activated, transmission may occur with the control lever in the RUN or STOP position, but not in the FREE position.

(c) Ambient relative humidity . . . . . From 0 to 95 percent

(d) Power consumption . . . . . KSR - 300 watts  
ASR - 550 watts

3.02 Physical Characteristics

(a) Dimensions . . . . . See Figure 15

(b) Weight . . . . . KSR - 225 pounds  
ASR (RT & KSR) - 345 pounds

(c) Power cord  
Purpose . . . . . Provides ac power for entire set  
Type . . . . . Single 3-pin polarized cord  
Length . . . . . 8 feet from back of cabinet

**Note:** A similar cord supplies power to the RT module.

(d) Intercabinet cable  
Purpose . . . . . Interconnects set logic  
Length . . . . . 4 feet

(e) Interface cord

Purpose . . . . . Provides the EIA (Electronic Industries Association) interface

Type . . . . . 25-conductor plug

Length . . . . . 6 feet

3.03 Set Internal Power Supply

(a) Multivoltage power supply  
Output voltages (dc) . . . . . Nominal +12.5 volts  
Max . . 6 amperes  
Nominal -12.5 volts  
Max . . 3 amperes  
Nominal +5.25 volts  
Max . . 3 amperes

(b) Utility Strip

Output voltages . . . . . 115 volts ac  
5.5 volts ac  
(for copylights)

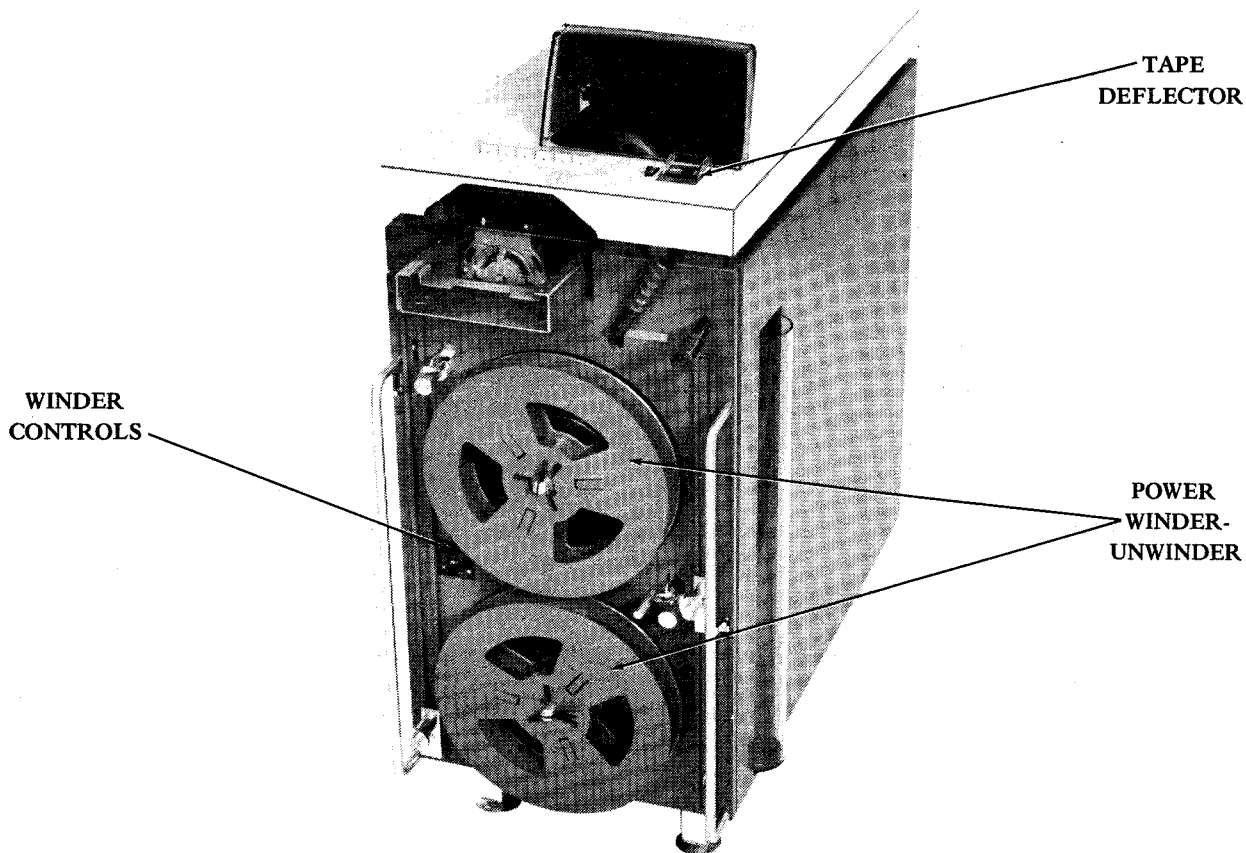

Figure 14 - Tape Handling Accessories

#### 4. OPERATION

##### GENERAL

4.01 The operation of the set is described in terms of the interface leads controlling both the sending and receiving devices and the communications channel (Figure 16).

4.02 As an example of a switched network application, the description of establishing and terminating a call applies to a set operating with telephone facilities.

##### PERIPHERAL INTERFACE

4.03 The following four leads (Figure 16) are used by the TTY set logic to prepare the set to receive data.

- (1) Receiver Selectable: This is an indication from the typing unit to set logic that the receiving device is selectable, ie, there is no condition, such as paper-out, which disqualifies it to receive a message. A receiver not selectable indication is an alarm condition which will allow a call already in progress to be completed and then prevent reception of another call.
- (2) Receive Message: This is a command from set logic to the receiving device to prepare for receiving a message. This would include, for example, starting the typing unit motor.
- (3) Receiver Ready: This is an indication by a selectable receiver, in response to Receive Message, that operations preliminary to receiving have been performed. For example, if the typing unit motor was started on receipt of Receive Message, Receiver Ready would be indicated after a timed interval during which time the motor reaches operating speed.



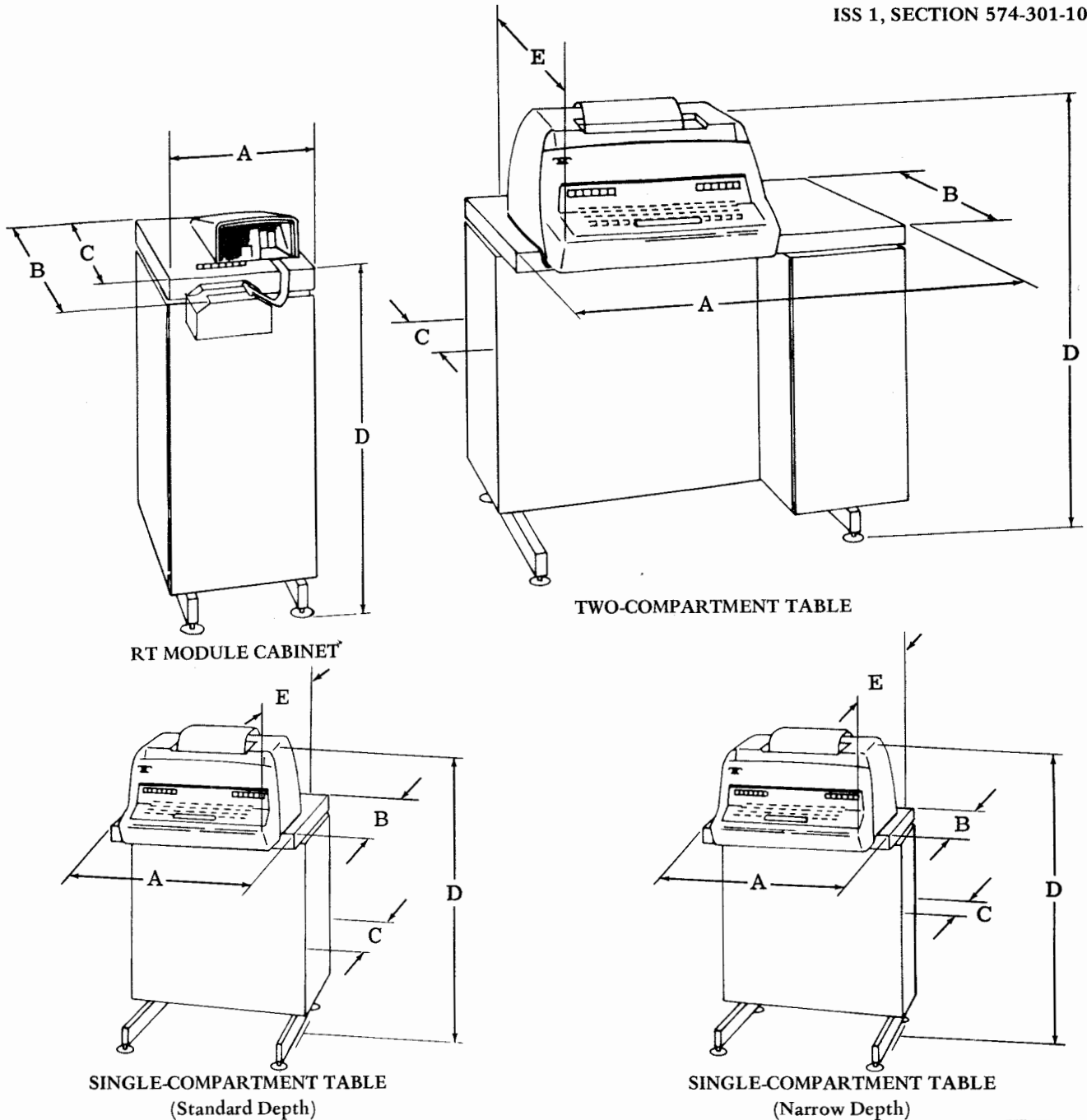

DIMENSION	RT MODULE (INCHES)	TWO-COMPARTMENT (INCHES)	SINGLE-COMPARTMENT (STD DEPTH) (INCHES)	SINGLE-COMPARTMENT (NARROW DEPTH) (INCHES)
A	12	32-1/2	22-1/2	22-1/2
B	26-3/4	23	23	17-1/8
C	23	14-1/2	14-1/2	8-5/8
D	26-1/2	36	36	36
E		27-3/8	27-3/8	21-1/2

Figure 15 - 37 Table Dimensions

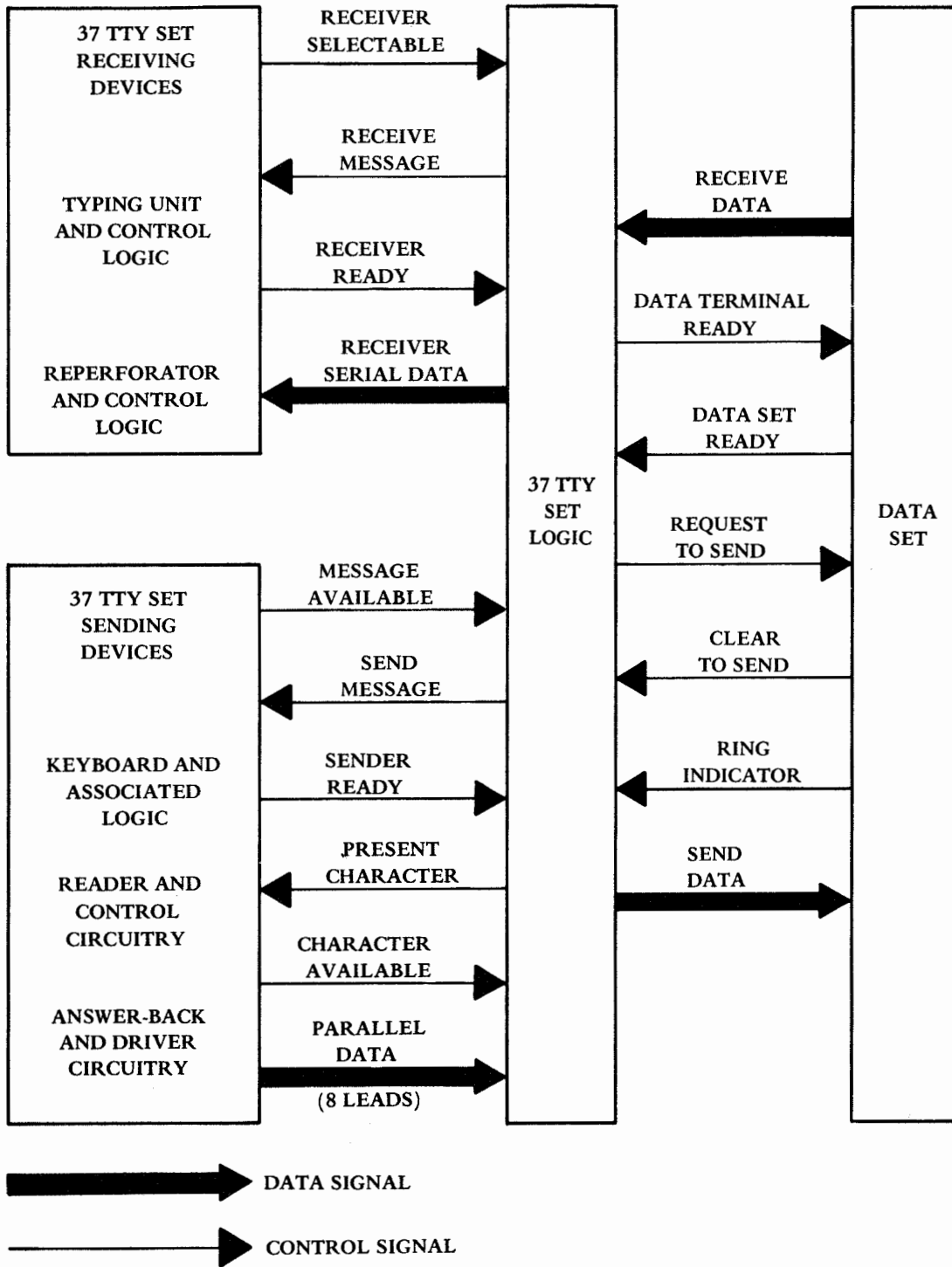

Figure 16 - 37 TTY Set Peripheral and Channel Interface

(4) Receiver Serial Data: The serial data on this lead is at set logic voltage and current levels. Logic zero is a space and logic one is a mark.

4.04 The following 13 leads (Figure 16) are used by the TTY set logic to prepare the set to transmit data:

(1) Message Available: This is an indication by the transmitting device to the set logic that it has a message to send. Once the set logic has responded, this indication is binding on the set.

(2) Send Message: This lead is used by set logic to acknowledge Message Available. It starts any preliminary operations required to prepare the transmitting device to transmit data.

(3) Sender Ready: This lead is used by the transmitting device to acknowledge Send Message and to indicate that preliminary transmitting operations have been completed and that the device is ready to produce a character.

(4) Present Character: This signal to the transmitting device acknowledges Sender Ready and directs the transmitter to place a character on the parallel signal buss.

(5) Character Available: This signal to set logic acknowledges Present Character and indicates the transmitter is displaying a character on the parallel signal input to the set logic. The character must be sampled by the distributor within the operation of this lead by the transmitter.

(6) Parallel Data: This is a set of eight leads on which characters are bussed in parallel from the transmitting device to the distributor for serialization.

#### CHANNEL INTERFACE

4.05 The channel interface signals conform to EIA Standard RS-232-B and are listed, along with the name, purpose, and pin number of each lead, in Table E. The leads which have designations beginning with A are ground leads. Interface leads which have designations beginning with B are data leads. Interface leads which have designations beginning with C are control leads.

4.06 The data leads are positive (+) or high for spacing signals and negative (-) or low for marking signals. A positive (high) voltage on a control lead means it is on, and a negative (low) voltage means it is off.

#### ORIGINATING AND ANSWERING

4.07 Data communication is started with the set in the idle condition – Request to Send (CA lead) permanently on, copylights off, and motor not running. Data Terminal Ready (CD lead) must be on, ie, an alarm condition must not exist and at least one receiving device is in the on-line mode. Under these conditions a data call can either be originated or answered.

4.08 While establishing a connection, the line interface unit at both the originating and answering sets should turn on the Data Set Ready (CC lead), remove the mark hold from Received Data (BB lead), turn on Clear to Send (CB lead). After Clear to Send, the set enables the Transmitted Data (BA lead). In addition, at the answering set, Ring Indicator (CE lead) is turned on after ringing occurs.

4.09 Ring Indicator (CE lead) at the answering set conditions the answer-back start logic circuitry so that when Clear to Send (CB lead) is turned on, a pulse is generated which starts the answer-back cycle, if so equipped.

4.10 When Data Set Ready (CC lead) at a set is turned on, the motor starts, and copylights go on. The PROCEED lamp located on the set control panel will light whenever Clear to Send (CB lead) is on, and the PROCEED pushbutton is operated, or after receipt of the ACK character in the presence of Clear to Send. The lighted PROCEED lamp indicates that transmission from the keyboard is enabled, and exchange of data can take place.

#### LOCAL OPERATION

##### A. Device Selection

4.11 The particular transmitting or receiving device to be used in local operation is selected by depressing the corresponding button on the control panel (Tables A and D). The selected pushbutton lamp will light to indicate the selection of local operation.

4.12 The reperforator unit has two controls: PUNCH LOCAL and PUNCH ON. For local operation, PUNCH ON and PUNCH LOCAL must be lighted to enable the reperforator to receive data.

##### B. Motor Control

4.13 The typing unit, reader unit, and reperforator unit motors are started by selection of OFF LINE or PRINTER LOCAL, READER LOCAL, and PUNCH LOCAL pushbuttons, respectively.

TABLE E  
EIA INTERFACE LEADS

DESIGNATION	NAME	PIN NO.	PURPOSE
AA	Protective Ground	1	To connect ac power service ground to equipment chassis. It is electrically isolated from signal ground.
AB	Signal Ground	7	To provide ground for all signal circuits.
BA	Transmitted Data	2	To carry set output data when the set is in the on-line mode and to remain "marking" when set is in the off-line (local) mode.  <u>Note:</u> When equipped with an INTRPT pushbutton, this lead will carry a timed "spacing" signal of nominally 500 ms duration each time the pushbutton is operated.
BB	Received Data	3	To present incoming data to the set when the set is in the on-line mode.  <u>Note:</u> If this lead is grounded at the interface, the set will act as if it were in the "marking" condition.
CA	Request to Send	4	To condition local line interface unit to transmit. This lead is connected permanently on by a strap in the set.
CB	Clear to Send	5	To inform terminal that local data set is ready to transmit any data presented on BA lead.  <u>Note:</u> This lead controls the operation of the PROCEED lamp and the starting of the answer-back, if so equipped.
CC	Data Set Ready	6	To inform set that local data set is connected to the transmission facility.  <u>Note:</u> When this lead is on, it causes set motors to start running.

TABLE E  
EIA INTERFACE LEADS (Continued)

DESIGNATION	NAME	PIN NO.	PURPOSE
CD	Data Terminal Ready	20	<p>To inform data set that the set is ready to receive data messages.</p> <p><u>Note:</u> The set is prepared to receive when:</p> <p>(a) No alarms are present.            (b) Set is not in "do not answer" mode.            (c) At least one receiving device is in on-line mode.</p>
CE	Ring Indicator	22	<p>To inform set that ringing current is being received, ie, the start of a received call.</p> <p><u>Note:</u> This lead primes the answer-back, if so equipped. When CB goes on, the answer-back will start sending automatically.</p>

### C. Message Exchange

4.14 The transmitting device selected presents Message Available to the send control logic. If no other transmitting device in the local mode has been given sending priority, the send control logic responds with a Send Message command.

4.15 When the transmitting device is properly conditioned, it initiates a Send Ready signal. At this time, provided no tabbing is in process and the local transmitting distributor is conditioned, the send control turns on the Present Character lead.

4.16 The transmitting device responds with Character Available. This results in serialization of the data in the local transmitter distributor.

4.17 The receiving devices which have been selected to operate in the local mode, as determined by the control panel pushbuttons, copy the message sent from that transmitting device which is also in the local mode. In the local mode the set ignores the condition of the Receiver Selectable and Receiver Ready signals and the receivers copy any data transmitted through the local distributor.

### LINE OPERATION

#### A. Device Selection

4.18 Transmitting and receiving devices to be placed on-line are selected by depressing the corresponding pushbutton on the control panel. A nonlighted pushbutton indication means line operation has been selected.

4.19 The typing unit must be selected for line operation if a call is to be established. Optionally the reperforator may be selected as the line receiver.

4.20 The PUNCH ON lamp must be on to enable the reperforator unit.

4.21 The READER AUTO pushbutton (lighted when depressed) permits on-line control of the reader unit by a remote station sending DC 1 (reader on) and DC 3 (reader off).

4.22 Automatic on-line control of the reperforator is provided by a remote station sending DC 2 (reperforator on) and DC 4 (reperforator off).

B. Channel Establishment

4.23 For stations equipped with telephone facilities, a call is placed and a connection between two stations is established before any teletypewriter data is transmitted. To answer the call, the called station must be in service and have no alarm conditions.

4.24 The calling station dials the called station, which turns on Ring Indicator. This primes the called station answer-back. Since the Data Terminal Ready lead is normally on (no alarms present), Data Set Ready turns on. This results in Clear to Send turning on and an indication that the connection is established.

C. Message Exchange

4.25 With Clear to Send on, messages may be exchanged when the PROCEED lamp lights. This is done automatically on receipt of the ACK character or manually by depressing the PROCEED pushbutton on the control panel.

4.26 Data transmission can be stopped on receipt of an interrupt signal. The PROCEED pushbutton must be depressed to reactivate the sending capability.

4.27 Data is exchanged between the transmitting and receiving sets at different stations using the line distributor for serialization.

4.28 The data exchange is a half-duplex operation, ie, the transmitted data is copied by the sending station. For sets so equipped, the on-line full-duplex mode of operation may be used to permit simultaneous two-way message exchange.

SIMULTANEOUS LOCAL-LINE OPERATION

4.29 The ASR set can be used in the local and line modes of operation simultaneously. As an example, the reperforator unit and keyboard may be switched to local and messages processed locally (keyboard to reperforator) and on-line (reader and typing unit).

CHANNEL TERMINATION

4.30 The PROCEED lamp will go out and the keyboard will be electrically disabled (blinded) for further data transmission whenever either the on condition of Clear to Send (CB lead) is lost, the NAK character is received, or the interrupt signal is received. If Clear to Send (CB lead) is on, transmission from the keyboard can be enabled again either manually by operating the PROCEED pushbutton or automatically by receipt of the ACK character.

4.31 The set will disconnect and data transmission will be automatically stopped upon receipt or transmission of the EOT character. The EOT signal causes Data Terminal Ready (CD lead) to momentarily turn off. With Data Set Ready (CC lead) on, the data set recognizes this condition as a request to disconnect and should cause disconnect to take place.

5. REFERENCES

5.01 The following sectionalized literature pertains to the 37 KSR and ASR Sets:

	<u>TITLE</u>	<u>NUMBER</u>
	<u>KSR SET</u>	
Installation		574-301-200
Removal and Replacement of Components		574-301-702
Field Maintenance Practice		579-400-350
	<u>ASR SET</u>	
Installation		574-302-200
Removal and Replacement of Components		574-302-702
	<u>MOTOR UNIT</u>	
Description and Principles of Operation		570-220-100
Adjustments		570-220-700
Lubrication		570-220-701
Disassembly and Reassembly		570-220-702
	<u>TYPING UNIT</u>	
Description and Principles of Operation		574-320-101
Adjustments		574-320-703
Lubrication		574-320-704
Disassembly and Reassembly		574-320-705
	<u>KEYBOARD AND BASE ASSEMBLY</u>	
Description and Principles of Operation		574-321-101
Adjustments		574-321-703
Lubrication		574-321-704
Disassembly and Reassembly		574-321-705
	<u>ELECTRICAL SERVICE UNIT</u>	
Description and Operation		574-322-101

<u>TITLE</u>	<u>NUMBER</u>	<u>TITLE</u>	<u>NUMBER</u>
<u>TABLE</u>		<u>NONTYPING REPERFORATOR</u>	
Description and Operation	574-323-101	Description and Principles of Operation	574-329-100
Adjustments	574-323-703	Adjustments	574-329-700
<u>TYPING UNIT COVER AND PAN</u>		Lubrication	574-329-701
Description and Operation	574-326-101	Disassembly and Reassembly	574-329-702
Adjustments	574-326-703	<u>TAPE READER</u>	
Lubrication	574-326-704	Description and Principles of Operation	592-801-100
<u>TYPING REPERFORATOR</u>		Adjustments	592-801-700
Description and Operation	574-330-100	Lubrication	592-801-701
Adjustments	574-330-700	Disassembly and Reassembly	592-801-702
Lubrication	574-330-701	<u>RT MODULE CABINET</u>	
Disassembly and Reassembly	574-330-702	Description and Operation	574-327-100
<u>ANSWER-BACK UNIT</u>		Adjustments	574-327-700
Adjustments	574-325-703	Lubrication	574-327-701
Lubrication	574-325-704		

