

CHAPTER 1

COUNTERMEASURES AN/WLR-1

INTRODUCTION

Electronic countermeasures (ECM) is the use of devices or techniques intended to impair the operational effectiveness of enemy electronic equipments or to detect the presence of enemy counter activities. Electronic countermeasures is classified as "active" or "passive." Passive ECM is the use of receiving equipments to intercept enemy radar or radio transmissions. Active ECM is the use of transmitting equipments to jam the enemy transmission.

GENERAL DESCRIPTION

Countermeasures Receiving Set AN/WLR-1 (fig. 1-1) is used in this discussion as a representative countermeasures equipment so that an analysis of countermeasures circuitry can be studied in detail. The AN/WLR-1 operates as a passive ECM equipment to receive any electromagnetic radiation in the frequency range of 50 mc to 10,750 mc. The receiver is a high-sensitivity superheterodyne capable of distinguishing between closely spaced signals.

The frequency range is covered by nine r-f frequency converter tuners (fig. 1-1) which overlap in frequency coverage. Any one of the tuners may be selected by means of a band switch on the control-storer unit. Either automatic sector scan or manual tuning is available. In sector scan operation, the complete frequency range of the selected tuner is covered in two seconds. In manual operation, the r-f tuner is positioned by a manual tune knob on the control-storer unit.

The receiving set supplies outputs which are presented on a high persistence raster-type indicator on the acquisition scope and a normal persistence indicator on the analysis scope. The high persistence raster is a pattern of scanning lines which, by horizontal scanning, illuminates the cathode-ray screen of the acquisition scope. Rapid scanning of the acquisition scope and the long persistence CRT display are utilized to provide a high probability of interception of any signal frequency in the

tuning range. The patterns displayed on each of the indicators are shown later.

The horizontal scan, which produces the raster on the indicator screen of the acquisition scope is swept in synchronism with the selected tuner as it is scanned through its frequency range. The vertical sweep is driven by a sawtooth voltage. The detected signals are applied as intensity modulation to the cathode-ray tube.

Because the horizontal position on the raster is proportional to frequency, received signals appear as a vertical series of spots while noise forms a random pattern. Therefore, detection of signals below noise level is possible due to visual integration. The scan (acquisition) scope retains information for approximately two minutes, allowing manual return to a detected signal for storage or analysis.

The analysis indicator presents direction finding, pulse analysis, and panoramic displays of the received signal simultaneously so that rapid analysis of the signal can be accomplished.

The analysis indicator employs a five-gun cathode-ray tube. The demodulated output of the received signal (a-m or f-m) is presented by the first three guns on three sequentially triggered traces (fig. 1-2) for measurement of pulse duration and repetition frequency.

The fourth gun provides linear direction-finding information on two calibrated scales separated vertically by three-fourths of an inch. Each scale represents 180° of rotation. The electron beam traverses the screen in synchronism with the antenna rotation. A received signal causes vertical deflection of the spot, proportional to the signal strength, at a point on the scale corresponding to the signal bearing.

The last trace on the analysis scope is a panoramic presentation of a portion of the frequency spectrum. The trace is 5, 10, or 20 megacycles wide (depending on the r-f tuner in use) centered about the tuner frequency.

The panoramic display involves the presentation of a received signal by synchronizing the

CIRCUITRY OF SHIPBOARD ELECTRONICS EQUIPMENT

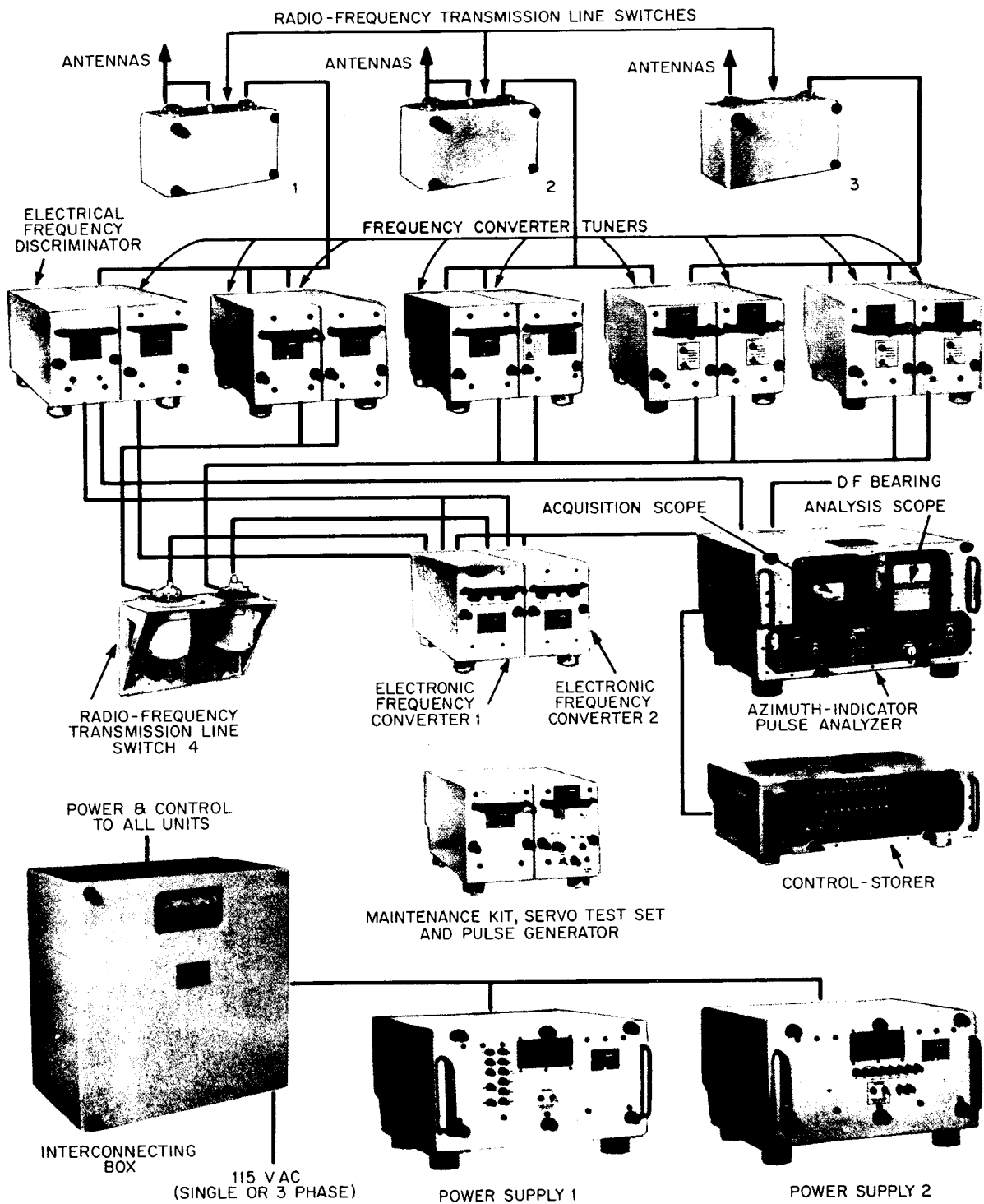

032.1

Figure 1-1.--Countermeasures Receiving Set, AN/WLR-1.

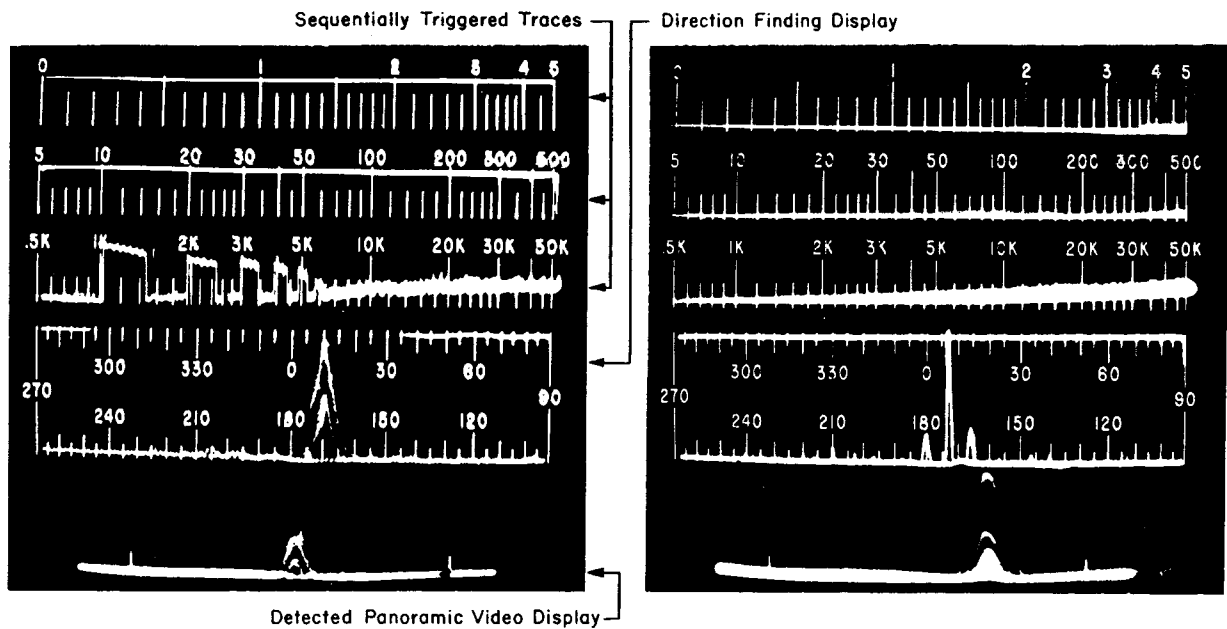

A. Analysis Scope; DF Display, 1 Kc
Square Wave, Antenna Speed 300 RPM,
Bearing 170 Degrees

B. Analysis Scope; DF Display,
CW Signal, Antenna Speed 40 RPM,
Bearing 170 Degrees

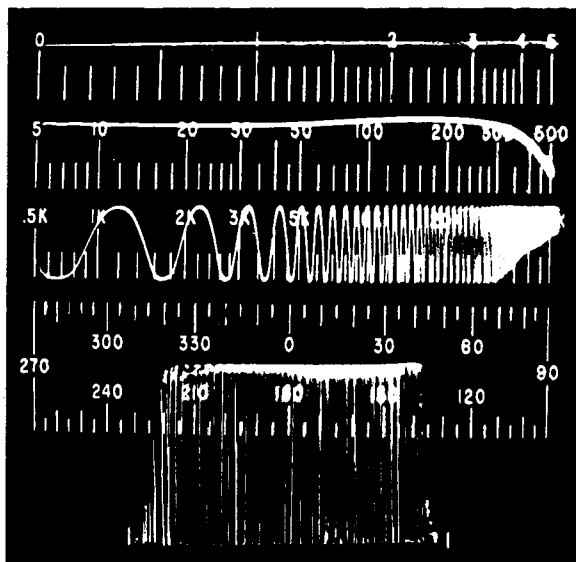

C. Analysis Scope; FM Signal, Sine Wave
Deviation 6 Mc Peak to Peak, Modulation
Frequency 1 Kc

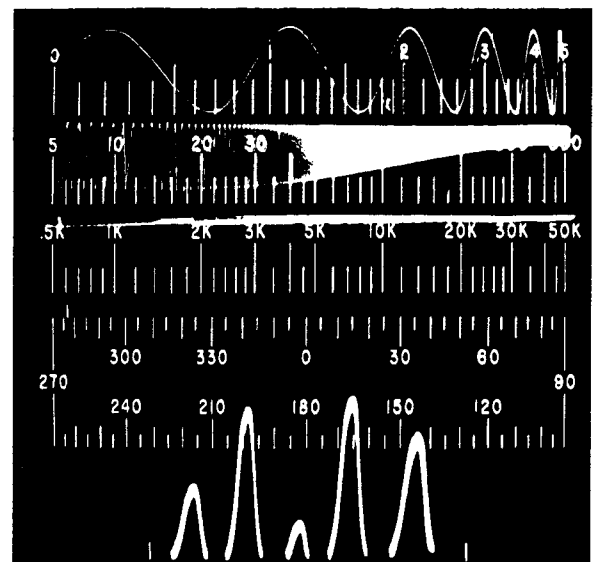

D. Analysis Scope; FM Signal, Sine Wave
Deviation 6 Mc Peak to Peak, Modulation
Frequency 1 Mc

032.2.1

Figure 1-2.—Analysis indicator presentations.

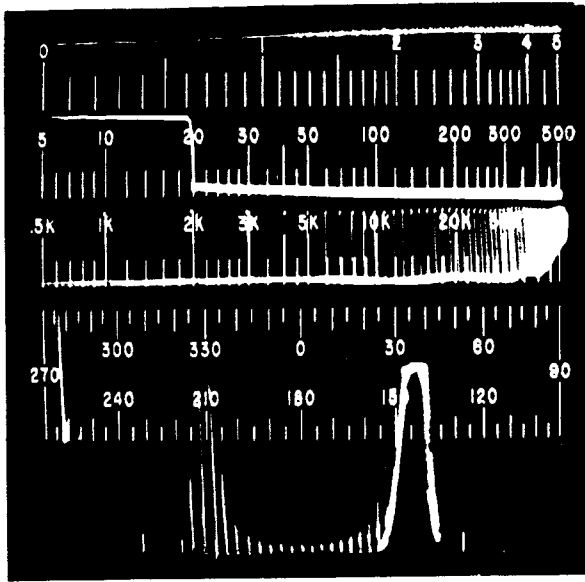

E. Analysis Scope; FM Signal,
6 Mc Peak Deviation Toward the Higher
Frequency, Pulse Width 20 Usec,
PRF 1 Kc

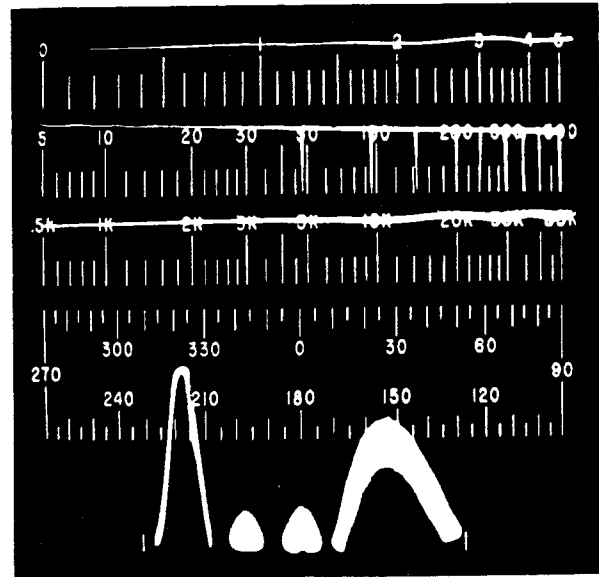

F. Analysis Scope; FM Pulsed Signal,
5 Mc Peak Deviation Toward the Lower
Frequency, Pulse Width 1 Usec,
PRF 20 Kc

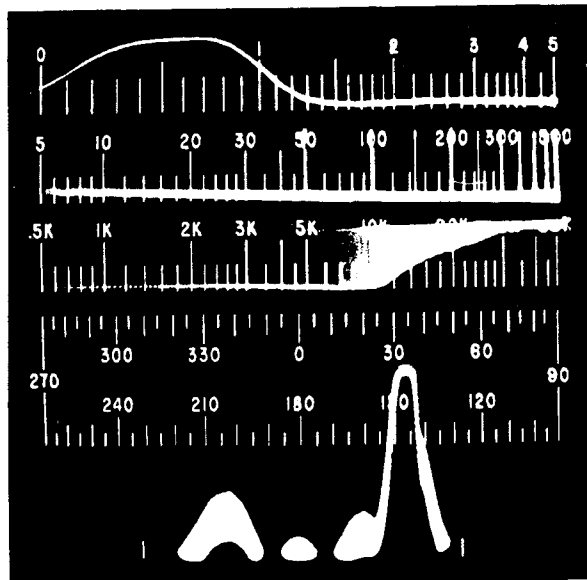

G. Analysis Scope; FM Pulsed Signal,
5 Mc Peak Deviation Toward the Higher
Frequency, Pulse Width 1 Usec,
PRF 20 Kc

032.2.2

Figure 1-2.—Analysis indicator presentations—Continued.

intermediate frequency with the horizontal sweep rate on the cathode-ray screen. In this manner the received signal amplitude is displayed as a function of the intermediate frequency with the center of the trace corresponding to the center of the i-f bandpass. The left half of the trace will show signals in the lower half of the i-f bandpass and the right half of the trace will show signals in the upper half of the i-f bandpass.

figure 1-3. The antenna switches (1, 2, and 3) select the low frequency (LF), medium frequency (MF), or high frequency (HF) antenna input. These switches feed the selected input to one of nine frequency converter tuners (1 through 9). The antenna switches are controlled by the band selector and the antenna selector switches on the control-storer.

The antennas used with the AN/WLR-1 countermeasures system are not treated in this discussion. The antenna switches 1, 2, and 3, connect either an omnidirectional or direction finding antenna to the receiver input.

The frequency converter tuners contain pre-selector and mixer stages as will be shown

BLOCK DIAGRAM

An overall block diagram of countermeasures Receiving Set AN/WLR-1 is shown in

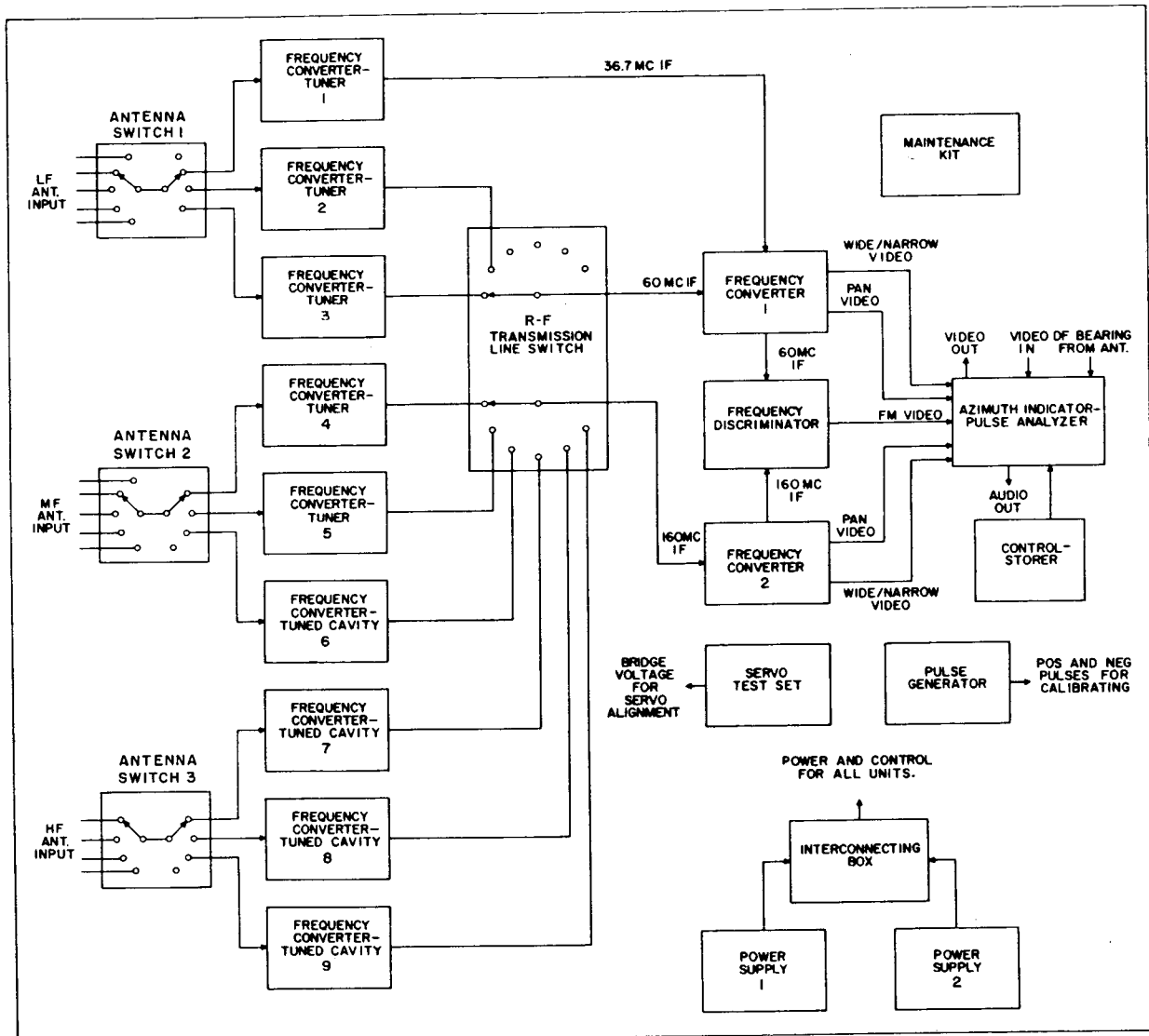

C32.3

Figure 1-3.—Countermeasures Receiving Set AN/WLR-1, block diagram.

later. The total frequency coverage of the receiving set is divided into nine bands. One frequency converter tuner is used for each band. The frequency ranges of each band are as follows:

- Band 1—50-100 mc
- Band 2—90-180 mc
- Band 3—160-320 mc
- Band 4—300-600 mc
- Band 5—550-1100 mc
- Band 6—1000-2600 mc
- Band 7—2300-4450 mc
- Band 8—4300-7350 mc
- Band 9—7050-10,750 mc

The output of the frequency converter tuner is an intermediate frequency. The frequency of this output is dependent upon the band on which the receiver is being operated. The i-f signal is fed through a radiofrequency transmission line switch which passes the selected frequency converter tuner output to either of two frequency converters (1 or 2, fig. 1-3).

The frequency converter provides amplification for the i-f signal from the converter tuner, detects the signal, and feeds it to the indicators for display. It also provides the horizontal sweep voltage for the panoramic sweep on the analysis scope.

The frequency discriminator produces demodulated signals from the f-m carrier for display and analysis on the indicator. The f-m signals are supplied to the frequency discriminator from either frequency converter 1 or 2.

The azimuth indicator-pulse analyzer provides visual and aural presentations of all intercepted signals. As mentioned previously two forms of visual presentations are used. The first is an acquisition (scan) scope using a raster-type presentation, the horizontal sweep being synchronized with the tuner as it is scanned through the frequency range. The second presentation consists of analysis information, i.e., time of occurrence of the signal, pulse duration, pulse repetition rate information and panoramic display. The analysis information is presented simultaneously on separate scales on the indicator.

The interconnecting box is used to interconnect the various units of the AN/WLR-1 system. The unit consists primarily of terminal boards, relays, line filters, and various wiring. The relays select the proper power and control voltage for all of the r-f circuits.

Power supply 1 converts the 115-volt a-c into d-c voltages. The power supply actually

contains six separate supplies, each having a different output voltage. The separate supplies provide the following: -1610 volts, -650 volts, +250 volts, +150 volts, +105 volts, and +28 volts. The -1610-volt and -650-volt supplies are energized only on bands 5 through 9.

The power supply contains a thirty-second time delay relay which allows time for filament warmup before primary power is applied to the separate supplies. A voltmeter is provided for monitoring the different voltages. A voltage selector switch on the front panel (fig. 1-1) provides the necessary switching for monitoring.

In addition to having the power supplies fused, added protection is provided by having the power supplies interlocked with the -150 volt supply. This prevents the energizing of any of the B plus or high voltage negative supplies until the -150 volt supply is operating correctly. It will also deenergize the power supplies in the case of loss of the -150 volts or a slight decrease in the -150 volt supply output.

Power supply 2 (fig. 1-3) also contains six separate supplies which provide eight different d-c voltages: +250 volts, -2500 volts, -2395 volts, +450 volts, +300 volts, +180 volts, +120 volts, and -150 volts. A voltmeter and voltage selector on the front panel of the unit provides monitoring of the different power supply voltages. Fuses are placed in the primary power lines for protection of the unit and in the output of the +180- and +120-volt supply to protect the rectifier and transformer from a short circuit.

CIRCUIT ANALYSIS

Each of the nine frequency converter tuners consists of a band-pass filter (fig. 1-4), an r-f preselector, a diode mixer, a local oscillator, an i-f preamplifier, and a servomotor. The preselector and local oscillator are tuned by a servo-tuning system which is automatically driven by a scan generator (shown later) during SCAN operation and manually tuned by the manual tune control during ANALYSIS operation.

The frequency converter tuner for each band performs basically the same function. Because of the wide frequency coverage of the AN/WLR-1, the components of the various tuners differ. For example, the relatively low frequency coverage of frequency converter tuner 1(50-100 mc) permits the use of conventional electron tube circuitry with negligible loss to the desired signals. However, the high frequencies utilized in frequency converter tuners 6

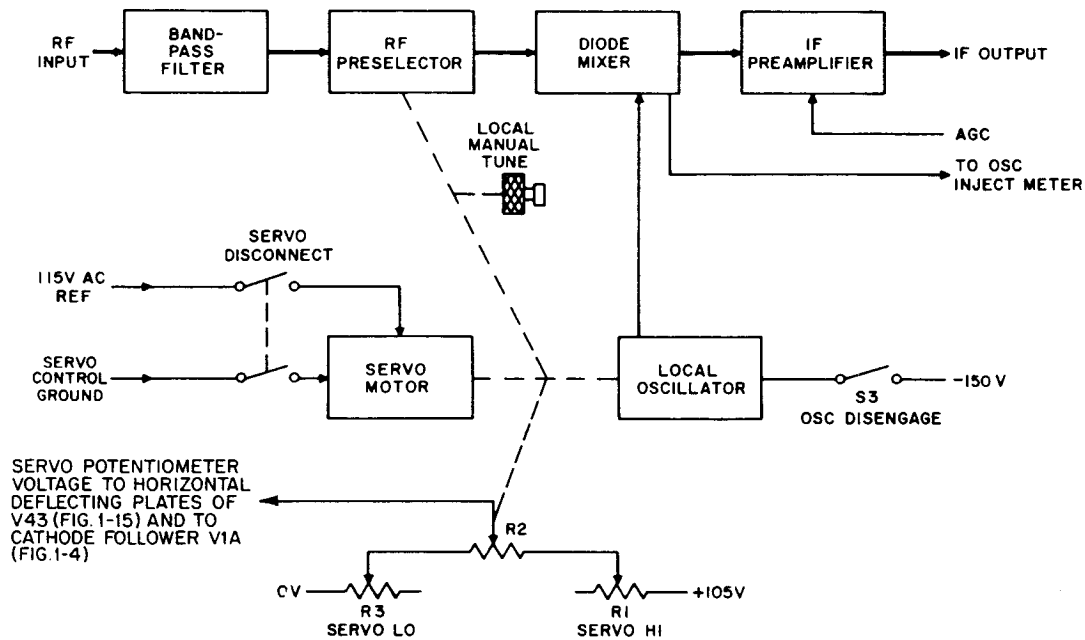

Figure 1-4.—Frequency converter tuner, block diagram. ^{032.4}

through 9 require the use of tuned cavities to keep the loss of the signal (as a result of shunting by stray capacitances) to a minimum.

Because the basic operation of all the frequency converter tuners is the same, the description is limited to one at the low-frequency end and one at the high-frequency end.

FREQUENCY CONVERTER TUNER (LOW FREQUENCY)

The r-f input from the antenna (fig. 1-5) is coupled to band-pass filter FL2. The filter provides attenuation at all frequencies outside of the r-f tuner range (50 to 100 mc).

Cascade connected tuner circuits ① and ② improve the selectivity at the receiver input; ② reduces the magnitude of adjacent channel frequencies already attenuated by 1 and builds up through resonance the center frequency already built up by ①. These actions increase the mid-frequency output and decrease the bandwidth as compared to a single-tuned circuit.

Capacitor C1 is tuned manually by the local manual tune control or automatically by mechanical linkage to servomotor B1.

R-f Amplifier

The signal from the L4 tap is applied via C2 to the cathode of grounded grid amplifier V1.

The grounded grid amplifier is used in high-frequency circuits to transfer the capacitance between grid and plate from its series position (with respect to the amplifier load) to a position such that it shunts the load. Because the value of the grid-plate capacitance is very small, the capacitive reactance is relatively large. Thus, the effects of signal shunting can be held to a minimum by keeping the shunt capacitance as small as practicable.

The V1 output is coupled to the tuned circuit comprising the T1 secondary, C3A and C3B. The frequency of this signal is between 50 and 100 megacycles.

Local Oscillator

The local oscillator circuit (V2) is a series-fed Hartley, with its cathode negative by a direct connection to the -150-volt supply, and its plate grounded through L5, L6, and R1. The oscillator is tuned by C1E and operates continuously in the frequency range from 86.7 to 136.7 megacycles.

Feedback, of the proper phase and sufficient magnitude to sustain oscillations, is applied from the plate to grid of V2 via L5 and C7. The oscillator output is inductively coupled by L7 to the T2 primary.

The oscillator signal at the T2 secondary is applied to the anode of crystal mixer CR1. The

amplified r-f signal at the T1 secondary is applied to the CR1 cathode.

Note that CR1 conducts a direct current from ground (at the bottom of the T1 secondary) through a portion of the T1 secondary, CR1, the T2 secondary, L9, L14 through L17, and R3 to the 105-volt B supply. The incoming r-f and local oscillator signals at CR1 vary the crystal current in a manner which produces the sum, difference, and two original frequencies.

Because the local oscillator signal tracks the r-f signal (by ganged tuning of the sections of C1), the difference frequency output of CR1 is always 36.7 megacycles. The difference frequency is selected at the input to i-f amplifier V3A by tank circuit L10 and C3.

I-f Amplifiers

The i-f preamplifier subassembly, A2, consists of a cascode amplifier, V3A and V3B, and two stagger-tuned i-f amplifiers, V4 and V5. The cascode arrangement of two i-f amplifiers is used because of its low noise characteristics (as compared to a single pentode) while the amplification is approximately the same as that of a pentode. (The two cascode tubes may be connected either in cascade or in series. The arrangement here is cascade. A series arrangement of cascode amplifiers is treated in chapter 13 of this training course.)

Because the tubes are connected in cascade, the bias on V3B must be such that the signal from V3A will not be distorted in V3B. The main purpose of V3B (a grounded grid amplifier) is to reduce the effect of signal loss through stray capacitances.

Tuned circuit L11-C4, at the V4 grid, is tuned above 36.7 mc, while the L12-C5 circuit at the input to V5, is tuned below 36.7 mc. This permits high gain in the respective circuits above and below the i-f center frequency (36.7 mc) and thereby increases the i-f bandpass. The frequency response curve (not shown) is essentially flat for about ± 1.5 mc above and below 36.7 mc. The i-f output from the V5 plate is fed through R4, L13, and C6 to output jack J1. The i-f amplifier output is fed directly to frequency converter 1.

Automatic gain control (agc) voltage for i-f amplifiers V4 and V5 is developed in the frequency converter (discussed later). This voltage is applied to i-f amplifier V4 via J1, L18 through L20 and L11, and to V5 through L18 and L19 only.

Servo Tuning Mechanism

A functional diagram of the servo-tuning mechanism is shown in figure 1-6. During normal operation, the servomotor tunes the r-f preselector and the local oscillator circuits. The servomotor also drives a servo-reference potentiometer which supplies position information to the servosystem.

A cam on the servo drive shaft actuates a band-limit switch which operates a band-limit light on the front panel of the azimuth indicator-pulse analyzer (fig. 1-1). This enables the operator to check the operation of the servo-tuning system.

During test, any one of the frequency converter tuners can be manually tuned by depressing the associated select button on the controller and engaging the local manual tune knob (fig. 1-6). When this is done, the servo disconnect switch opens and the servomotor is disabled.

A frequency dial on the servo drive shaft indicates the converter tuner frequency setting. End stops on the frequency dial prevent the servomotor from over-running during a malfunction which might cause damage to the tuned circuits. A clutch mechanism in the servo drive assembly prevents damage to the servomotor.

The tuner servosystem has two modes of operation, scan and analysis. In SCAN operation, the scan button (fig. 1-14, B) is depressed, and the r-f tuner (frequency converter tuner) is automatically tuned back and forth through its frequency range. In ANALYSIS, with one of the ten select buttons depressed, the r-f tuner frequency is controlled by the manual tune crank.

FREQUENCY CONVERTER TUNER (HIGH FREQUENCY)

Frequency converter tuners 6 through 9 use special circuit components designed for use in high frequency applications. The discussion of converter tuner 6, which follows, is also applicable to converter tuners 7 through 9.

Preselector

The r-f preselector of the high-frequency converter tuner (fig. 1-7) is essentially a tunable band-pass filter, which consists of three coaxial-cavity, overcoupled tuned circuits. The coaxial cavities operate as one-quarter wavelength resonant lines, open-circuited at

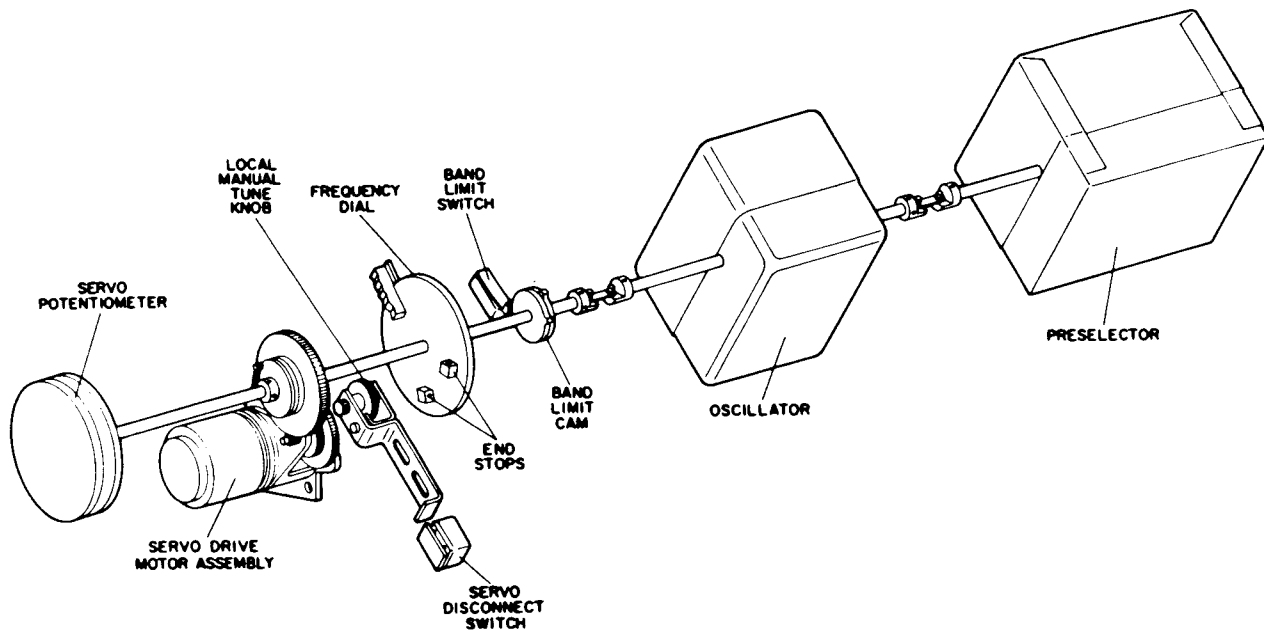

Figure 1-6.—Servo-tuning mechanism, functional diagram. ^{032.6}

one end and short-circuited at the other end.

The cavities are tuned to the desired electrical length by axial movement of the center conductors, or plungers. To eliminate the problems associated with sliding contacts, such as tuning noise, erratic contacts, friction, and wear, a noncontacting short circuit to the center conductor is provided at the end of each cavity.

Because the space between the noncontacting short-circuiting element and the center conductor is small, a separate ball-bearing guide (not shown) is used to support each center conductor and to keep it concentric within the noncontacting element. The center conductors, or plungers, are ganged together and driven by the tuning servomotor.

The input to the preselector is fed along a 50-ohm coaxial section, through an aperture to a 50-ohm tap on the preselector cavity. Similar apertures couple the three cavity sections. The output of the third cavity is coupled through a coaxial section, similar to the r-f input section, to the crystal mixer, CR1.

Local Oscillator

The local oscillator, V1 (fig. 1-7) uses a reflex klystron which operates in the frequency range from 710 to 1260 megacycles. The oscillator operates 160 mc above the frequency of the r-f preselector.

The oscillator is tuned by noncontacting short-circuiting plungers, which move in the output cavity resonator. The plungers are driven by the servo-tuning motor.

The oscillator frequency change, obtained by positioning the resonator plungers, is supplemented by a simultaneous change in repeller voltage. The repeller voltage network consists of three voltage regulator tubes (V2, V3, and V4) connected in series. These tubes maintain a constant voltage (366 volts) across the series combination of resistors R2B, R4, and R5. This action keeps the V1 cathode 366 volts positive with respect to the repeller.

The repeller voltage is set by first setting the R2B arm to its center position, and then varying the setting of R4 and R5 until the desired repeller voltage is obtained. Note again that the arm of R2B is ganged to the servo-tuning system, and continuously varies the repeller voltage as the local oscillator is being tuned.

Resistors R4 and R5, respectively, provide fine voltage adjustment at the low and high frequency ends of the tuning range. Adjustments of these controls compensate for variations in klystron characteristics or for manufacturing tolerances.

The local oscillator output (at 160 mc above the incoming r-f signal) is fed through R1 to the cathode of crystal diode CR1. The r-f incoming signal is also applied to the CR1

cathode. Heterodyning at CR1 produces the 160-mc i-f signal which is fed through C1 and developed by L1 at the V5 i-f amplifier cathode.

Two cascade grounded grid amplifiers (V5 and V6) are used as the input stages to the i-f amplifier subassembly. The grounded grid type amplifier is used here for the same reasons given for the low-frequency converter tuner.

I-f Amplifiers

The i-f amplifiers, V7 and V8, are conventional intermediate-frequency amplifiers. Tank circuit L2-C2 in the V7 grid circuit is tuned below the 160-mc i-f signal while L3-C3 at the V8 grid is tuned above the intermediate frequency. Thus, the i-f stages are stagger tuned to increase the overall i-f bandpass. The i-f signal is fed via R3, C4, and J2 to the r-f transmission line switch (fig. 1-3) to frequency converter 2.

The agc potential developed in frequency converter 2 (discussed later) is fed into frequency converter 6 via J2. This potential is applied through L5 and L3 to the V8 grid and thus controls the gain in V8. The high impedance of L5 and the low impedance of C5 to the 160-mc i-f signal prevents feedback from the V8 plate to grid. Also, C5 provides an i-f ground for L3 to complete the V7 i-f tank circuit.

R-F TRANSMISSION LINE SWITCH

The r-f transmission line switch (fig. 1-8) selects one of the r-f tuner (frequency converter-tuners 2 through 9) outputs and connects it to either frequency converter 1 or 2 (fig. 1-3),

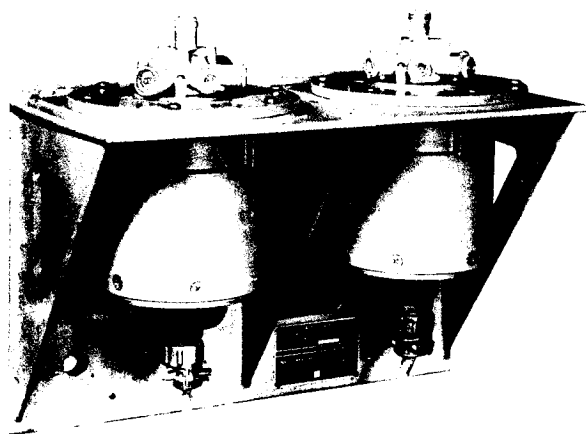

Figure 1-8.—R-f transmission line switch.

depending on the selected input frequency. This unit consists of two coaxial-type actuator switches as shown in figure 1-9.

I-f signals from frequency converter-tuners 2 and 3 (fig. 1-3) are fed through the upper section of the line switch, which corresponds in figure 1-9 with the left section (K1501). I-f signals from frequency converter tuners 4 through 9 (fig. 1-3) are fed through the lower section of the line switch, which corresponds to the right-hand line switch section (K1502) in figure 1-9. Band 1 (fig. 1-3) feeds its output directly into frequency converter 1.

The line switch (fig. 1-9) operates as an actuator-type relay. The circuit is energized by one of eight control wires in conjunction with one common wire.

Assume that it is desired to select a frequency between 190 and 320 mc (band 3). The band selector switch on the control-storer (fig. 1-1) is turned to the band 3 position. This action applies 115 volts a-c to pin B on plug P1501 (fig. 1-9). Assuming the plug is connected to the jack (J1501), the 115 volt a-c will cause a current from pin B on J1501, through pins 2 and C of S1A, through the motor, and out pin G to ground thereby returning to the a-c supply.

As the motor turns, it drives the actuator, S1A, and the coaxial switch 1 until an open circuit appears at pin 2 on S1A. This action de-energizes the motor. The arm of coaxial switch 1 is now making contact with terminal 2, and the input from frequency converter tuner 3 (band 3) is selected.

The selection of any of the other bands at the control-storer (except band 1) applies 115 volts a-c to the motor (fig. 1-9). Action similar to that just described then drives the motor until the desired frequency converter-tuner is selected.

FREQUENCY CONVERTER 1

Depending on the positions of antenna switch 1 and the r-f transmission line switch, frequency converter 1 receives an input from frequency converter tuners 1, 2, or 3. Inputs from frequency converter tuners 2 or 3 are amplified and detected. However, the input from frequency converter tuner 1 must be heterodyned to produce a 60 mc i-f prior to amplification and detection. As mentioned earlier, the frequency converter also provides a horizontal sweep voltage for the panoramic sweep of the azimuth indicator pulse analyzer. Amplitude modulated outputs from frequency converter 1

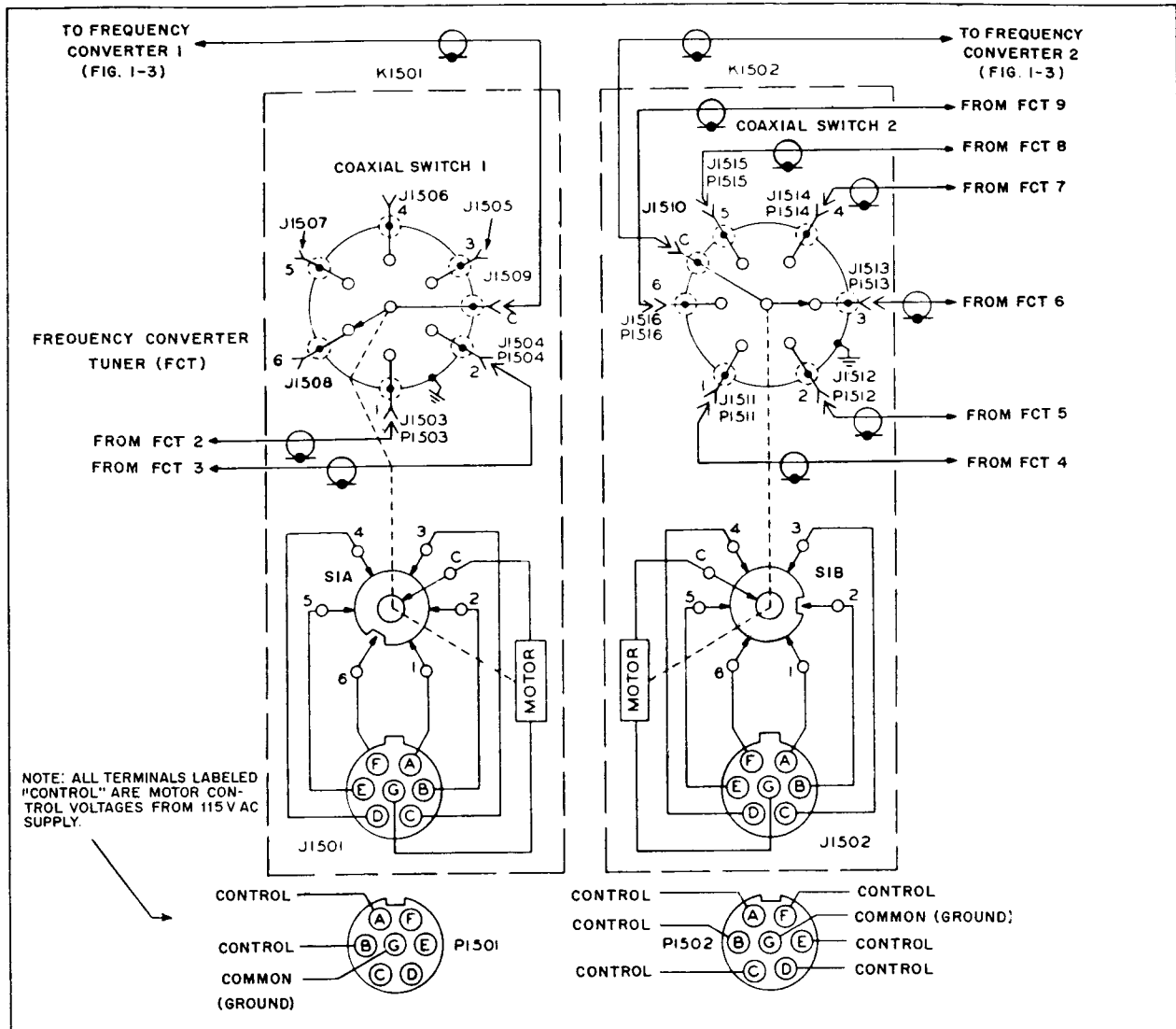

Figure 1-9.—R-f transmission line switch, schematic diagram. ^{032.9}

to the indicator include a wide-band and a narrow-band video signal from which the signal characteristics are determined. Either of these two video signals can be selected by a bandwidth switch (on the control-storer in fig. 1-1) for analysis.

The wide bandwidth output contains the modulation components of all signals present in the 6.5-mc bandwidth centered at 60 mc. The narrow bandwidth output includes a band of signals 0.25 mc wide centered about the 60-mc intermediate frequency.

Frequency converter 1 also supplies a panoramic-video output and an i-f output for frequency-modulated signals. A block diagram

of frequency converter 1 is shown in figure 1-10.

Wide Band Operation

Frequency converter 1 receives an i-f input only when band 1, 2, or 3 is selected by the operator. This unit, in turn, supplies a detected signal to the azimuth indicator-pulse analyzer only on these bands.

The desired frequency converter-tuner (r-f tuner) is selected by the band selector control on the control-storer. On band 1, frequency converter-tuner 1 feeds a 36.7-mc i-f signal to mixer stage V2 (fig. 1-10). The

36.7-mc signal is heterodyned with a 23.3-mc signal from crystal oscillator V1. This action produces a sum frequency of 60 mc (the required intermediate frequency) which is fed to i-f amplifier V3.

On bands 2 and 3, the i-f signal from frequency converter-tuners 2 and 3, respectively, is already 60 mc and requires no additional heterodyning. The crystal oscillator continues to operate but has no effect because the output tank of the mixer is still tuned to 60 mc. Thus, mixer stage V2 acts as a conventional amplifier to the 60 mc component.

The 60-mc i-f amplifier, V3, is followed by six additional i-f stages (V4 through V9) which are tuned alternately above and below the 60-mc center intermediate frequency (stagger tuned). This produces the desired i-f amplification and increases the i-f bandpass to the required 6.5 megacycles.

The 60-mc (± 3.25 mc) output of the last i-f amplifier, V9, is fed to a wide band detector V10, and to a 60-mc isolation amplifier V12. The wide band detector (V10) extracts the video modulation from the i-f signal and applies it to the output via cathode follower V11.

During wide band operation, bandwidth switch S32 is in the WIDE position, and wide-narrow relay K1 is deenergized (as shown). In this condition, the wide band video output (from V11) is connected through the upper contacts of K1A to the azimuth indicator-pulse analyzer.

Isolation amplifier V12 is used to provide impedance matching between the last i-f amplifier V9 and the input to the frequency discriminator. The frequency discriminator is used to amplify and detect f-m signals for subsequent display on the azimuth indicator-pulse analyzer. It should be noted that the f-m content of the received signal has been preserved by the wide bandpass of all of the previous amplifier stages.

Stage V12 also supplies the input to the agc stages, and to the narrow band stages via 60-mc isolation amplifier V13.

Narrow Band Operator

The narrow band stages produce either a panoramic output or narrow band output which is fed to the azimuth indicator-pulse analyzer. The panoramic output is produced in the following manner.

The upper K1B contacts supply B voltage for either the fixed oscillator V15, or for the frequency sweep oscillator, V16. The lower K1B contacts supply B voltage for the pan sweep

generator, V19, in the deenergized position only.

As stated earlier, during wide band operation, relay K1 is deenergized (in the position shown). Thus, the frequency sweep oscillator V16 is energized (by application of the +150 volts), and the fixed oscillator, V15, is deenergized. In this condition, the local oscillator injection into the narrow band mixer, V21, is provided by the frequency sweep oscillator V16.

The V16 output is swept through a range of frequencies between 46.5 and 51.5 mc by a sawtooth waveform produced in pan sweep generator V19. The sawtooth waveform fed to the grid of reactance tube V17 is tapped from a voltage divider at the V20 grid.

The cathode follower, V18, is used in the phase shift network. The amount of phase shift is such that when amplified in reactance tube (V17) it produces an inductive effect in shunt with the oscillator (V16) grid tank coil. The amount of apparent inductance varies with the amplitude of the sawtooth voltage.

The frequency sweep oscillator output is fed to narrow band mixer V21 where it is heterodyned with the 60-mc i-f signal from V13. The V21 output is the difference between 60 mc and the sweep oscillator frequency—that is, it varies between 8.5 and 13.5 mc. The tank circuits at the input to narrow band i-f amplifier V22 are tuned to 11 mc and have a bandwidth of 0.25 megacycles. The amplified narrow band signal is detected by CR3 and fed through cathode followers V23A and V23B to the lower K1A contacts and to the azimuth indicator-pulse analyzer, respectively.

The V23B output is used for panoramic display of the received signal. In the panoramic type of presentation (fig. 1-11) an oscilloscope is used whose horizontal deflection voltage varies linearly with frequency and whose vertical deflection voltage is proportional to signal amplitude. The horizontal deflection voltage for the panoramic display on the azimuth indicator-pulse analyzer is applied to the panoramic scope from V20 (fig. 1-10). Because the same sweep voltage is used to sweep the i-f signal through its range, the horizontal sweep voltage changes proportionately to frequency changes. The sweep voltage (as it is generated in V19) is at a 30-cps rate, synchronized by a 60-cps input.

The video output bandwidth of V23A (0.25 mc) contains a narrower band of frequencies than that provided at the V11 output (6.5 mc bandwidth). The narrow band output is selected by

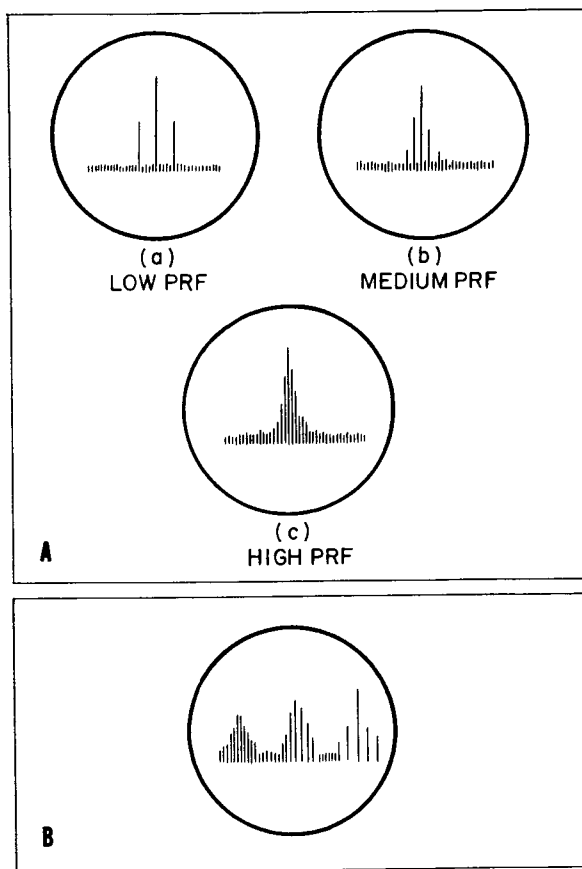

Figure 1-11.—Appearance of pulsed radar signal on oscilloscope.

the operator when closer observation of a signal received in wide band operation is desired. Narrow band will also aid in more accurate tuning of a single signal.

Narrow band operation is selected by placing S32 in the NARROW position. This action causes wide-narrow relay K1 to operate and the K1A contacts are moved down (opposite to position shown). The K1B contacts are also moved to a position opposite to that shown. This removes the B+ voltage from frequency sweep oscillator V16, pan sweep generator, V19, and applies the B+ voltage to the fixed oscillator V15, thus enabling this oscillator.

The fixed oscillator produces a 49-mc output which is applied to mixer V21. The heterodyning process in V21 permits only those frequencies which are in the center of the i-f (or 11 mc \pm 125 kc) to be passed through the V21 mixer output to the narrow band i-f amplifier V22. The narrow band output of V22 is detected by CR3 and fed via V23A and the lower contact of K1A

to the azimuth indicator-pulse analyzer. The signal which is now presented on the panoramic display, due to lack of panoramic sweep, is useful for tuning purposes only.

Automatic Gain Control

The input to the agc stages from isolation amplifier V12 (fig. 1-10) is rectified by CR2 and fed through cathode follower V14 to agc limiter CR1. The filtered output is fed to the upper contact of the function selector switch, S36.

When S36 is in the position shown, the agc voltage output is applied to i-f amplifiers V3, V5, and V6, and to the i-f amplifiers in the selected frequency converter-tuner (1, 2, or 3). This voltage aids in controlling the gain of these stages.

When S36 is in the AM-MGC or VIDEO position, manual control of signal gain is provided by the gain control on the control-storer chassis.

FREQUENCY CONVERTER 2

The 160-mc i-f signal output of any one of frequency converter-tuners 4 through 9 (fig. 1-3) is applied to i-f amplifier V1 in frequency converter 2 (fig. 1-12). This unit performs the same function as frequency converter 1 and is very similar in its operation. The difference is primarily the frequency of the i-f channel.

The r-f tuner used is selected by the band selector switch on the control-storer. The intermediate frequency applied to V1 of frequency converter 2 is always 160 mc. Therefore, a wide band mixer (similar to that at the input of frequency converter 1) is not needed in frequency converter 2.

The wide band stages consist of nine stagger-tuned i-f amplifiers (V1 through V9) followed by a wide band detector V10 and a cathode follower V11. The stagger-tuned i-f amplifiers produce a 20-mc bandpass. Relay K1A operates the same as previously described to feed the wide band output to the azimuth indicator-pulse analyzer for display (discussed later).

The narrow band stages receive the i-f signal via 160-mc isolation amplifiers V12 and V13, and feeds the i-f signal to narrow band mixer V21. The mixer output circuit is tuned to 39 mc, and thus produces a larger amplitude output at this frequency.

The heterodyne input to V21 is applied from fixed oscillator V15 (during narrow band operation) and from the frequency sweep oscillator

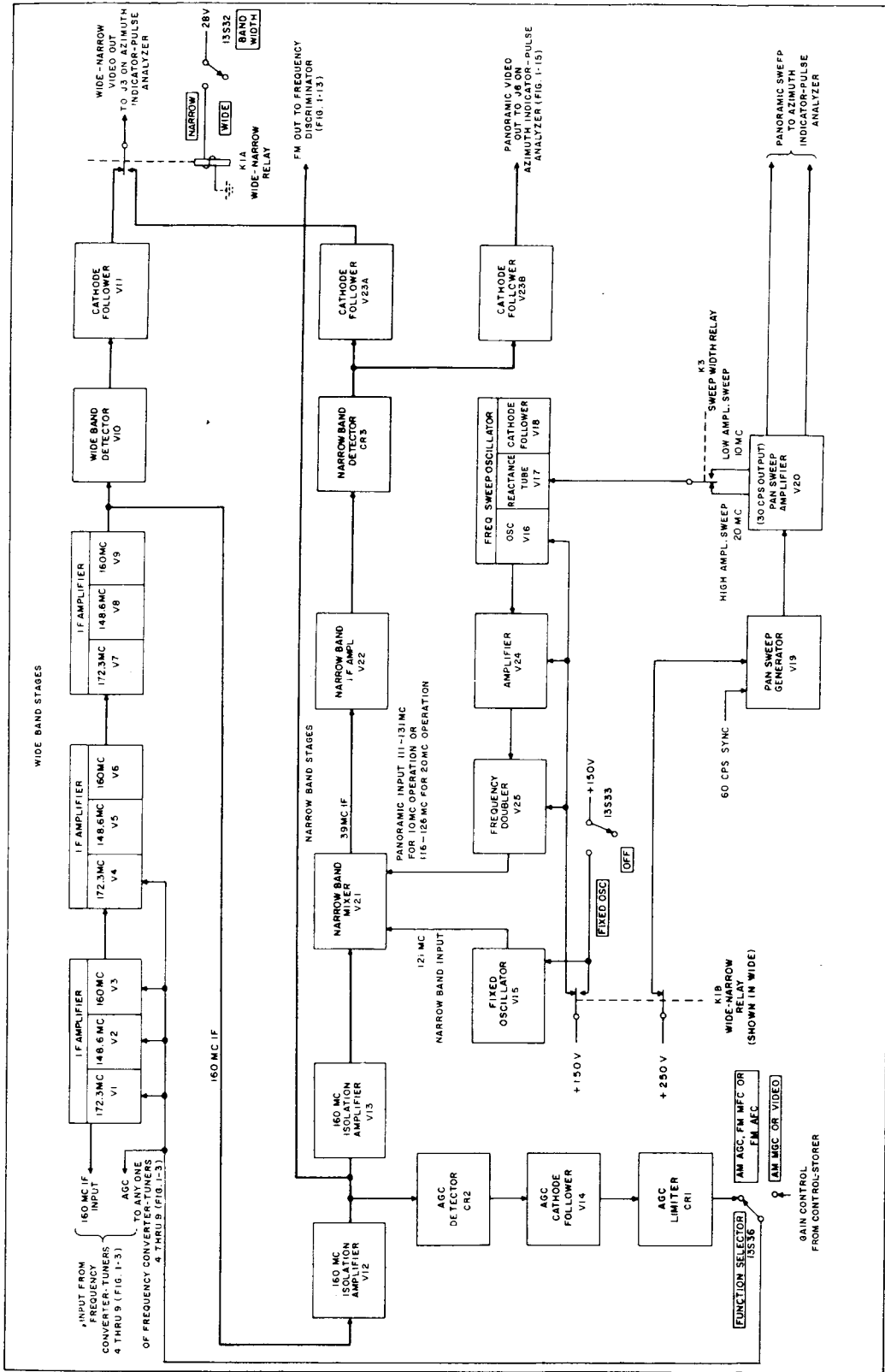

Figure 1-12.—Frequency converter 2, block diagram.

(comprising V16, V17, V18, V24, and V25) during wideband operation. Wide-narrow relay K1B operates the same as described in the discussion of frequency converter 1 to select either of the two oscillator circuits.

Pan sweep generator V19 produces a 30-cps output which is amplified in V20. The sawtooth output causes the reactance tube V17 to sweep the oscillator (V16) frequency through a frequency range determined by the amplitude of the sawtooth voltage.

Sweep width relay, K3, selects either a high amplitude or low amplitude sweep signal from a voltage divider in the grid circuit of the pan sweep amplifier V20. The high amplitude output sweeps the frequency sweep oscillator frequency through a 20-mc range. The low amplitude output produces a 10-mc sweep in the oscillator frequency.

In the low amplitude (10-mc) position of K3, the input heterodyne frequency to the narrow band mixer V21 scans between 116 and 126 megacycles. This produces a 39 mc \pm 5 mc output from V21. The high amplitude sawtooth input to V17 produces a heterodyne input to V21 which scans between 111 and 131 mc to produce a 39-mc \pm 10 mc output. Thus, the two positions of K3 correspond to the 10-mc bandwidth and 20-mc bandwidth positions, respectively.

The selected input is fed through mixer V21 and the narrow band stages to the azimuth indicator-pulse analyzer. This input is used in the azimuth indicator-pulse analyzer in presenting the video analysis and panoramic displays on the analysis scope.

FREQUENCY DISCRIMINATOR

The frequency discriminator (fig. 1-13) supplies the demodulated signals obtained from an f-m carrier to the azimuth indicator-pulse analyzer. The f-m signal input to the frequency discriminator is obtained from either frequency converter 1 or 2 depending on the band in use.

During operation on the low three bands (using tuners 1, 2, and 3), relay K1 is energized (opposite to the position shown) from the +28-volt supply. In this condition, the 60-mc signal from frequency converter 1 is amplified in the triple-stage stagger-tuned second i-f amplifier strip comprising V6, V7, and V8.

During operation on bands 4 through 9, K1 is deenergized and the input signal is received at 1st mixer V1 from frequency converter 2. This signal (160 mc) is reduced to a 60-mc i-f by heterodyning with the 220-mc local oscillator (V5) output. The 60-mc output of V1 is

amplified in stagger-tuned stages V2 through V4, fed through the upper contacts of relay K1, again amplified in stages V6 through V8, and applied to limiter V9.

The limiter stage removes all amplitude modulation from the i-f signal and applies its output to amplifiers V10 and V11 and to 2nd mixer V12.

Amplifiers V10 and V11 supply inputs to the 20-mc bandwidth and 6-mc bandwidth discriminators, respectively. The discriminator used is selected by the f-m bandwidth switch S31, located on the front panel of the control-storer. When S31 is in the 20 mc position (as shown), relay K2 is deenergized and relay K3 is energized as shown. This action selects the output of the 20-mc bandwidth discriminator as the input to video amplifier V15. When the f-m bandwidth switch is in the 6 mc position, relays K2 and K3 are energized (lower contacts closed) and the output of the 6-mc discriminator is connected to the input of V15. The amplified video signal is fed to the azimuth indicator-pulse analyzer for display.

The second mixer V12 heterodynes the 60-mc i-f signal from limiter V9 with a 49-mc input from the afc oscillator and amplifier. Frequency control of the oscillator is necessary to prevent drifting of the heterodyne frequency. This would produce an erroneous frequency at the V12 output. The difference frequency from V12 (11 mc) is fed through amplifiers V13 and V14 to the .23-mc bandwidth and 1.2-mc bandwidth discriminators, respectively.

If the f-m bandwidth switch, S31, is placed in the 1.2 mc position, K4 is energized (lower contacts closed) and K3 is deenergized (upper contacts closed). This action feeds the output of the 1.2-mc discriminator to video amplifier V15. When S31 is in the 0.23 mc position, relays K3 and K4 are deenergized and the output of the 0.23-mc discriminator is fed to V15. Resistor R11 attenuates the discriminator output.

The f-m bandwidth switch S31 has a fifth position designated the .05 mc position. When S31 is placed in this position, relay K5 is energized. The K5 contacts short R11 to provide a higher voltage output from the 0.23-mc discriminator thereby calibrating the analysis sweeps of the azimuth indicator pulse analyzer for measuring f-m deviation less than 0.05 mc.

During operation with the function selector switch, S36, in the FM MFC position (as shown), relay K6 is deenergized and a fixed output of 49 mc is fed from the afc oscillator and amplifier stages to 2nd mixer V12. However, when S36 is in the FM AFC position and S31 is in the

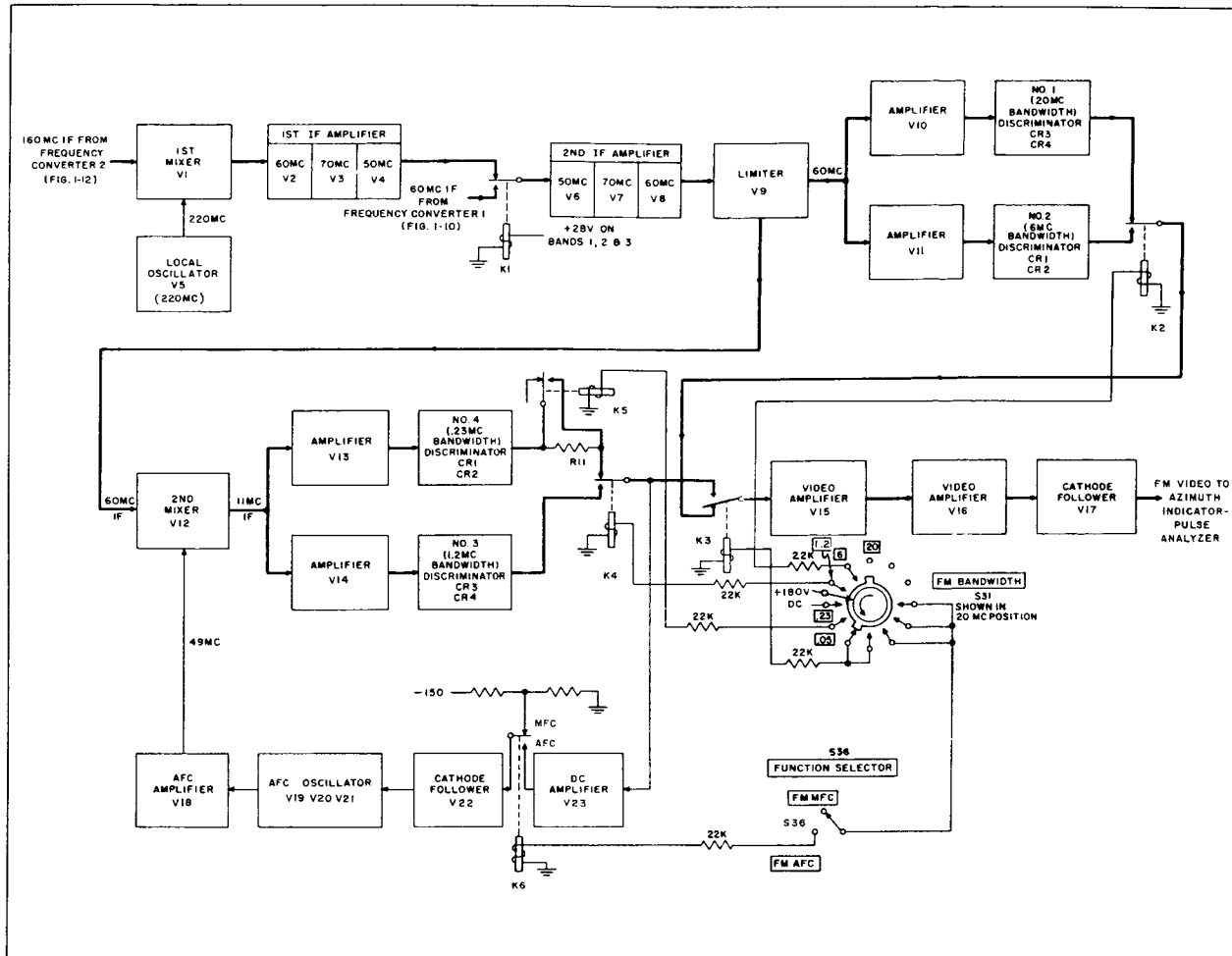

Figure 1-13.—Frequency discriminator, block diagram.

1.2 mc, 0.23 mc, or .05 mc position, relay K6 is energized, and a feedback voltage from the output of either the 1.2-mc or 0.23-mc discriminator (depending on the position of S31) is applied to d-c amplifier V23.

The afc circuit performs in the following manner: If the frequency of the 60-mc i-f input to 2nd mixer V12 increases, the output of the discriminator becomes predominately negative. This negative-going voltage is applied to the control grid of d-c amplifier V23 and reproduced at the V23 plate as a positive-going output. The output voltage is filtered to remove ripples.

Relay K6 is energized (due to conditions described earlier) and the positive-going filtered (d-c) output of V23 is fed through the lower K6

contacts, through cathode follower V22 (without phase inversion), to a reactance tube in the afc oscillator. The positive-going voltage reduces the bias on the reactance tube and the gain of the tube increases. This causes a corresponding change in the reactance presented to the oscillator tank circuit. The net result is an increase in the oscillator frequency which counteracts the increase in the 11-mc 2nd mixer center frequency output.

The reverse action takes place when the discriminator output causes the V23 output to become negative-going. This condition increases the reactance tube bias (makes the reactance tube grid more negative), and thus produces a decrease in oscillator frequency.

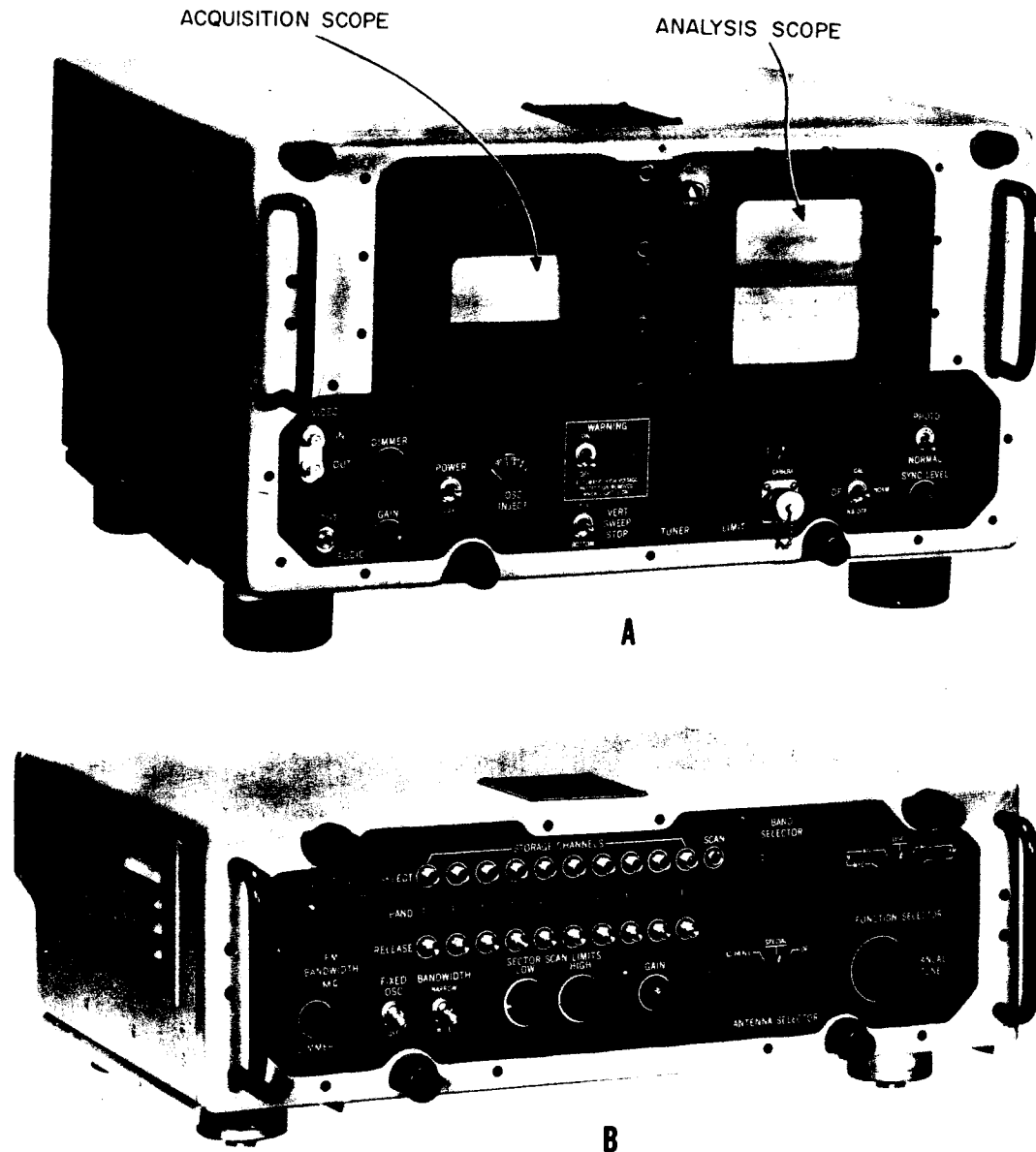

A. Azimuth-indicator pulse analyzer

B. Control-storer

032.14

Figure 1-14.—Pictorial diagrams.

AZIMUTH INDICATOR-PULSE ANALYZER

As mentioned earlier, the azimuth indicator-pulse analyzer (fig. 1-14, A) provides visual and aural presentation of all intercepted signals. Two forms of visual presentation are used. The first is an acquisition scope using a high-persistence raster type presentation, the horizontal sweep being synchronized with the tuner as it is scanned through its frequency range. The second is an analysis scope which represents all

analysis information simultaneously. Signal frequency information is supplied on a direct reading frequency indicator.

Some of the controls for the azimuth indicator-pulse analyzer are located on the front panel of the control-storer (fig. 1-14, B). The circuit discussion of this unit is presented later in this chapter.

VIDEO INPUT CIRCUITS

The azimuth indicator-pulse analyzer block diagram is shown in figure 1-15. The analysis scope input is applied from any one of the jacks J3, J4, J5, J8, or J12. The wide or narrow band video signal from frequency converter 1 or 2 is fed to the azimuth indicator-pulse analyzer via J3 or J4. This input is subsequently displayed on the analysis scope. Relay K1 selects the signal output from frequency converter 1 (at J4) on bands 1, 2, and 3, or the output from frequency converter 2 (at J3) on bands 4 through 9.

Relay K2 is energized (opposite to the position shown) when the function selector switch (fig. 1-14, B) is in either the FM MFC or FM AFC position. Thus, f-m signals received at J5 from the frequency discriminator output (fig. 1-13) are fed into the azimuth indicator-pulse analyzer, and subsequently displayed on the analysis scope.

Depressing the scan button on the control storer will deenergize K2 regardless of the position of the function selector. This action prevents missing an a-m or c-w signal intercept during scan due to accidentally leaving the function selector in the FM position.

In the CAL position, DF switch S2 provides a DF calibration signal from the DF antenna control via J8. Relay K3 disables the DF switch during scan operation.

External video-in jack J12 on the front panel of the azimuth indicator-pulse analyzer (fig. 1-14, B) provides a means of using the analysis scope for presenting signals from other receivers or from a signal generator. The video-in jack has an input impedance of 120 ohms. The external video input is fed through cathode follower V15 to video-out jack J15. This jack provides a convenient means of checking the output from all of the previous stages in the AN/WLR-1. It should be noted that the signal level at J15 is lower than the input signal level due to the loss in gain of cathode follower V15.

ACQUISITION SCOPE

The acquisition (scan) scope provides signal presentation on a raster type scope display (fig. 1-16). The horizontal sweep is synchronized with the r-f tuner as it is scanned through its frequency range. The vertical sweep signal is generated in the azimuth indicator-pulse analyzer.

The received signals are presented as intensified dots on each horizontal scan on the acquisition scope. Visual integration of the signal is

accomplished by repeating the horizontal traces below one another. Thus, a signal appears as a vertical line of intensified dots on the scan scope while noise appears as random dots.

Horizontal Sweep Circuits

Control voltage for the horizontal sweep is obtained from the r-f tuner servo potentiometer R2 (fig. 1-4). The sweep voltage amplitude therefore changes as the r-f tuner input frequency changes. The sweep voltage is amplified in V6 (fig. 1-15) to the level required to drive the horizontal winding of the deflection yoke of the acquisition scope, V43.

Vertical Sweep Circuits

The vertical sweep generator, B1 (a motor), drives the wiper arm of a potentiometer (similar to that in figure 1-4) and thereby produces a sawtooth sweep voltage with a period of approximately two minutes. The vertical sweep voltage is amplified in V5 (fig. 1-15) and applied in push-pull to the vertical winding of the deflection yoke of V43.

Video Circuits

Video signals are applied to the cathode of V43. The signal to be displayed on V43 can also be applied to the azimuth indicator-pulse analyzer, V44, via J3, J4, J5, J8, or J12. In any case, the signal is fed through V16, V17, delayed 0.2 μ s in DL1, amplified in V19 and fed through cathode followers V20 and V21 to cathode follower pulse stretcher V7. The 0.2 μ s delay in DL1 allows the sweep circuits of the indicator to be triggered before the video is amplified to the vertical plates. Thus, the leading edge of fast rising signals will not be lost.

Stage V7 introduces pulse stretching to increase the width of the video pulse and increase the screen intensity for narrow pulses. The V7 output pulse is fed to gated amplifier V8. A gate pulse from V35 gates on V8 for 500 μ s. The V35 output gate pulse is also applied through gating diode CR20 to the output of pulse stretching stage V7. This action ensures the termination of pulse stretching in V7 after 500 μ s.

To obtain an indication on c-w signals, a signal from the panoramic video input (J6 or J7) is used. Because of the heterodyning process in frequency converter 1 or 2, as discussed, c-w signals are applied to the azimuth indicator-pulse analyzer as a series of pulses,

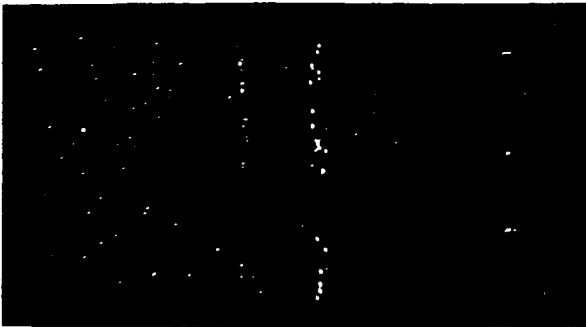

Acquisition Scope; Weak CW Signal

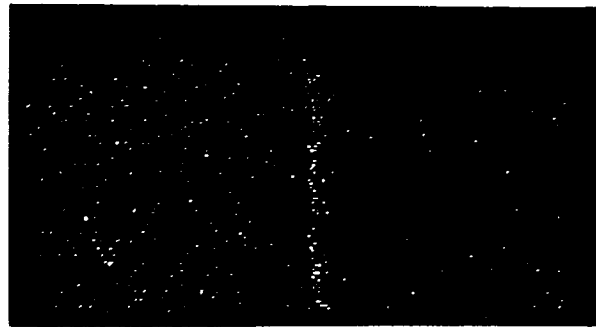

*Acquisition Scope; Weak Pulsed Signal,
Pulse Width 10 Usec, PRF 1 Kc*



*Acquisition Scope; Medium Strength
Pulsed Signal, Pulse Width
10 Usec, PRF 1 Kc*



*Acquisition Scope; Strong
Pulsed Signal, Pulse Width
10 Usec, PRF 1 Kc*

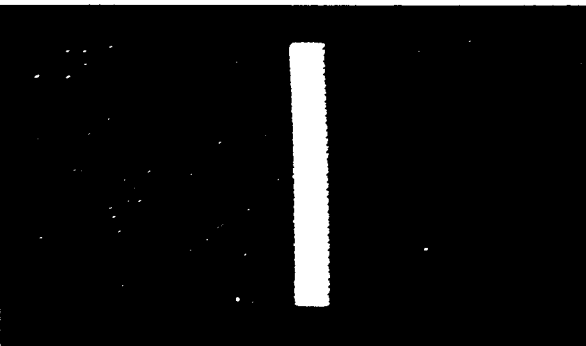

*Acquisition Scope; Very Strong
Pulsed Signal, Pulse Width
10 Usec, PRF 1 Kc*

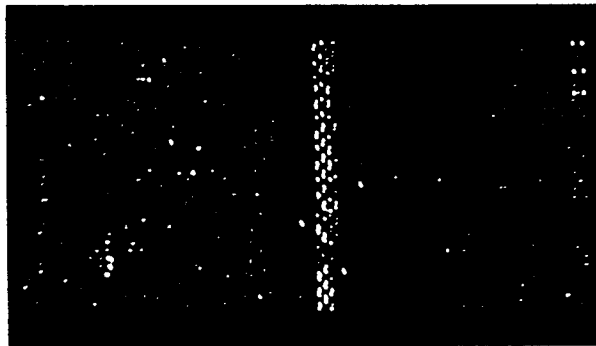

*Acquisition Scope; Medium Strength
Pulsed Signal, Pulse Width
10 Usec, PRF 30 PPS*

032.16

Figure 1-16.—Acquisition scope presentation.

having a repetition rate equal to that of the heterodyne oscillator sweep frequency.

Relay K1 selects the panoramic signal from frequency converter 1 (at J7) on bands 1, 2, and 3, and from frequency converter 2 (at J6) on bands 4 through 9. The input signal is amplified in pan video amplifier V1, and fed via cathode follower V2 to a low-pass filter FL1. This filter passes only the low-frequency component of the pulses which are amplified in narrow-band amplifiers V3 and V4 and fed through cathode follower V9 to the cathode of acquisition scope V43.

ANALYSIS SCOPE

One process in analyzing a video signal involves the determination of the type of modulation and the duration of the modulating signal. Thus, the analysis scope must be capable of reproducing the modulating wave on a sweep trace of sufficient duration to show one or more complete recurrences of the modulating voltage.

Modulating signals of 50,000 μ s or less can be displayed on the analysis scope. The total sweep consists of three separate horizontal traces which present a continuous display from 0 to 50,000 microseconds (fig. 1-2).

The demodulated output of the received signal is presented at the azimuth indicator-pulse analyzer by the first three cathode ray guns, V44C B and D, of the analysis scope cathode-ray tube as sequentially triggered traces for measurement of pulse duration and repetition frequency. The first trace covers the period from 0 to 5 μ s of the scan, the second trace from 5 to 500 μ s, and the third trace from 500 to 50,000 μ s.

Sweep Circuits

The first sweep trace (0 to 5 μ s) is initiated by the video signal applied to sync amplifier V18 from cathode follower V17. This input corresponds in time with the leading edge of the received signal. This signal is fed through V25 to sync pulse generator V26. The triggering level of the sync pulse generator is determined by the setting of the sync level control on the azimuth indicator-pulse analyzer (fig. 1-14, A).

The sync pulse is amplified by gated amplifier V28 (fig. 1-15) and used to trigger the 5- μ s multivibrator V29. One section of the multivibrator produces a positive output. The trigger derived from the trailing edge of this positive gate triggers the lockout multivibrator, V27. A negative gate from the lockout

multivibrator causes V28 to reject incoming sync pulses for the duration of the V27 gate input. This action prevents double triggering of the sync circuit. During the rejection period, the 5- μ s multivibrator sweep circuits are allowed to recover, thereby ensuring stability of recurring sweeps.

The sawtooth sweep voltage is generated in V30 by the exponential discharge of a capacitor in an RC network. A linear sawtooth voltage is not required in producing the sweep trace for the countermeasures display. Rather, the sweep speed decreases exponentially from 0 to 50,000 microseconds. This action further increases the maximum sweep duration. The screen is graduated in accordance with the decrease in speed of the sweep trace so that the accuracy in reading is preserved.

Stage V30 is triggered by the sync pulse from 5- μ s multivibrator V29. The exponential sweep voltage is amplified in V31 and applied to the horizontal deflection plates of the 0- to 5- μ s scope V44C.

Simultaneously with the development of the sweep voltage, a 0- to 5- μ s gate from V30 is applied to an intensity tailoring circuit. This circuit, which is essentially an RC time constant network, feeds an enabling voltage to the V44C control grid thereby causing intensification of the V44C screen display.

The 5- μ s multivibrator V29 also supplies a sync pulse to gated amplifier V32. This stage is a part of the circuit which produces the 5- to 500- μ s sweep voltage for V44B.

The operation of the 5- to 500- μ s sweep circuit is similar to the 0- to 5- μ s sweep circuit just discussed. The sync pulse from V32 triggers 495- μ s multivibrator V34. This stage, in turn, supplies input trigger pulses to the sweep generator and amplifier V36 and to lockout multivibrator V33. The lockout multivibrator, V33, supplies a pulse to V32 which causes V32 to reject incoming sync pulses for the duration of the V33 input gate.

The sweep generator, V36, produces the 5- to 500- μ s sawtooth waveform which is amplified in V37 and applied to the V44B horizontal plates. An associated intensity tailoring circuit produces the intensification voltage for the V44B control grid.

The 500- to 50,000- μ s sweep circuit operation is similar to the 0- to 5- μ s and 5- to 500- μ s circuits. The sync pulse is applied to gated amplifier V38 from V34. The 500- to 50,000- μ s horizontal sweep voltage from sweep amplifier V42 is applied to the horizontal deflection plate of V44D.

by a 5-volt grid-cathode negative bias. The cathode of V22A is connected in series with the plate of stretch control amplifier V23, effectively making the V23 d-c internal resistance between plate and cathode a part of the total V22A cathode resistance.

Positive video pulses applied to the V22A control grid from V21 cause V22A to increase conduction. This action charges capacitors C6 and C7 (at the V22A cathode). At the end of the positive-going video pulse to the V22A grid, this tube section returns toward cutoff. Capacitors C6 and C7 discharge through R14 and V23. Because R14 is fixed, the time required for C6 and C7 to discharge is determined by the d-c internal resistance of V23. The higher the internal resistance, the longer the time required for the C6-C7 discharge.

The long discharge time of C6 and C7 (as compared with the charge time) produces a pulse at the V22A cathode which is longer in duration than the pulse applied at the grid. Thus, the input pulse is stretched.

The stretched pulse at the V22A cathode is directly applied to the grid of cathode follower V22B. This pulse is developed across R15 and applied to the upper vertical deflection plate of the 5- to 500- μ s cathode-ray tube V44B (fig. 1-15).

Because the sweep speed of the horizontal trace is exponential, the amount of pulse stretching must constantly be changed from the beginning to the end of the sweep. This requirement is accomplished by applying a stretch control waveform to the control grid of the stretch control amplifier, V23, from sweep amplifier V37. The use of the sweep voltage to control the stretch tube ensures that the amount of stretch at any point on the sweep will be proportional to the horizontal speed of the sweep trace at that point.

The stretch control voltage polarity is negative at the V23 grid. At the beginning of the sweep, V22A and V23 are conducting and the internal resistance of V23 is low. The effective V23 resistance in the C6 and C7 discharge path produces negligible stretching. As time passes, the control voltage drives V23 further in the cutoff direction, and the effective internal resistance of V23 increases. This produces more stretching. Thus, greater stretching of the video pulses is provided as the sweep approaches the 50,000- μ s limit.

The 500- to 50,000- μ s pulse stretching circuit is similar to the 5- to 500- μ s circuit. The stretch control voltage for the 500- to 50,000- μ s sweep is obtained from V42, and amplified in

V24 (fig. 1-15). This stretched output of V13 is applied to the 500- to 50,000- μ s analysis tube V44D.

DIRECTION FINDING DISPLAYS

Direction finding (DF) information is used in determining the origin of a received signal. The DF information is obtained from a rotating DF antenna (not shown). The direction finding presentation is displayed on the two lower horizontal traces of the analysis scope (fig. 1-2, A and B).

The upper of the two scales (read left-to-right) represents rotation of the antenna from 270° to 0° to 90°. The lower scale (read right-to-left) represents rotation of the antenna from 90° to 180° to 270°. Thus, as the antenna rotates slowly in a clockwise direction, the spot starts at 0° in the center of the upper trace and moves to the right to the 90° position. At the 90° position, the spot drops suddenly to the lower scale and moves to the left, past 180° at the center of the bottom scale, to the 270° position at the extreme left of the bottom scale. At the 270° position, the spot jumps suddenly back to the upper scale and moves toward 0° in the center of the upper scale.

Thus, the direction finding trace is, in effect, coupled to the antenna and indicates the angular position of the antenna whether it is stopped or rotating at rates up to 330 rpm in either direction.

Signals received when the antenna angular position corresponds to a position on the upper trace cause a downward deflection from the trace. Signals received when the antenna angular position corresponds to a position on the lower trace are displayed upward from the trace. The trace is intensified only when a signal is present.

DF Sweep Circuits

The fixed rate at which the electron beam traces the DF display makes it necessary to generate a sweep voltage which has a linear rise and linear decay (triangular waveform). A modulated carrier system is used to generate a linear sweep from the angular rotation of the DF antenna.

The DF oscillator subassembly, All (fig. 1-15) generates an 11-kc carrier. A two-phase resolver voltage modulates the carrier.

The resolver includes a single-phase rotor winding and two stator windings displaced 90 degrees. The rotor is energized from the 11-kc oscillator and this signal is coupled through

transformer action to the two stator coils. As the rotor turns at a speed proportional to the antenna speed a rotationally induced voltage is also generated in the two stator coils. These actions result in amplitude modulating the 11-kc carrier so that the envelope frequency is proportional to the antenna rpm, figure 1-18 ①.

The resolver is geared down 2 to 1 in speed (with respect to the antenna speed). Thus, as the antenna rotates through 360° (fig. 1-18) the resolver rotates through 180°. To secure the desired relationship between the antenna and the DF display, the resolver is electrically positioned 90° ahead of the antenna.

The resolver has two output voltages—one is a sine function of the antenna angular shaft position equal to $K \sin 1/2 (\theta + 90^\circ)$ where K is a constant, and the other is a cosine function equal to $K \cos 1/2 (\theta + 90^\circ)$. Angle θ refers to the antenna relative bearing. The sine output is amplified in V45 (fig. 1-15), and fed through positive rectifier CR3 and CR4. The cosine output is amplified in V46 and fed through negative rectifier CR1 and CR2.

Adder stage V47 and V48 adds the negative of the cosine function with the positive of the sine function as illustrated at ③ in figure 1-18. Neglecting losses, this voltage is a triangular waveform and equal to

$$V = K \sin \left[\frac{\theta + 90^\circ}{2} \right] - K \left[\cos \frac{\theta + 90^\circ}{2} \right].$$

This voltage is applied to the control grid of sweep amplifier V49 (fig. 1-15). The triangular waveform input to V49 is amplified and applied to the horizontal deflection plates of the DF display gun, V44E.

If just the horizontal position of the spot were used to indicate the antenna angular position, every portion of the trace except the end points would correspond to two possible antenna angular positions. To eliminate this ambiguity, the direction of deflection of the horizontal trace is shifted vertically each 180°.

Each time an output of the resolver passes through a null point (fig. 1-18) the phase of the output carrier changes. The carrier components of the sine and cosine outputs are in phase (same instantaneous polarity) between antenna bearings of 90°-180°-270° of antenna rotation and out of phase (opposite instantaneous polarity) from 270°-0°-90°. These alternately in-phase and out-of-phase voltages are fed through drivers V45 and V46 (fig. 1-15), respectively, and through cathode followers V50 and V51 to a series of amplifier and clipper stages. These

amplifier and clipper stages produce square waves which are either in phase or 180° out of phase with each other. The square waves are applied to differential amplifier V56.

The differential amplifier is essentially a push-pull amplifier type phase detector. The stage produces an output when the input square waves from clipper CR9-CR10 are out of phase with the square wave input from CR11-CR12. An in-phase relationship between the two clipper input square waves will not produce a V56 output.

When there is a V56 output, rectifier CR13 and CR14 rectifies the output square wave. The rectify output is zero volts from 90°-180°-270° and a positive voltage from 270°-0°-90°. This voltage is applied to electronic switch V57.

The electronic switch produces an output which controls the deflection control tubes and amplifiers (V58 through V61). From 270°-0°-90° the square wave output to DF display tube V44E, after being fed through the deflection control and amplifier circuits, causes the upper deflection plate of V44E to be positive with respect to the lower plate, and the electron stream is deflected to its upper position. From 90°-180°-270° the lower deflection plate of V44E is positive with respect to the upper plate, and the electron stream is deflected to its lower position.

Some cathode-ray tubes do not have the gun mounted at the correct angle to display the rectangular DF sweep in alignment with the engraved scale without correcting signals. These signals are provided from horizontal skew controls (not shown). The horizontal skew control is used to shift the upper trace to the right or left with respect to the lower trace. The vertical skew control is used to tilt the left-hand portion of the display up or down with respect to the right-hand portion.

DF Video Deflection

Direction finding video signals are obtained within the azimuth indicator-pulse analyzer from either of two sources: pulse stretcher V14, or narrow-band amplifier V3. The stretched signal from V14 is further stretched by CR21. The CR21 output is fed through cathode follower V12 to DF video mixer V10. The V10 output is fed to direction finding display tube V44E via the deflection control and amplifier stages.

The narrow band amplified input from V3 serves as the direction finding video input to V10 when c-w signals are being received. This

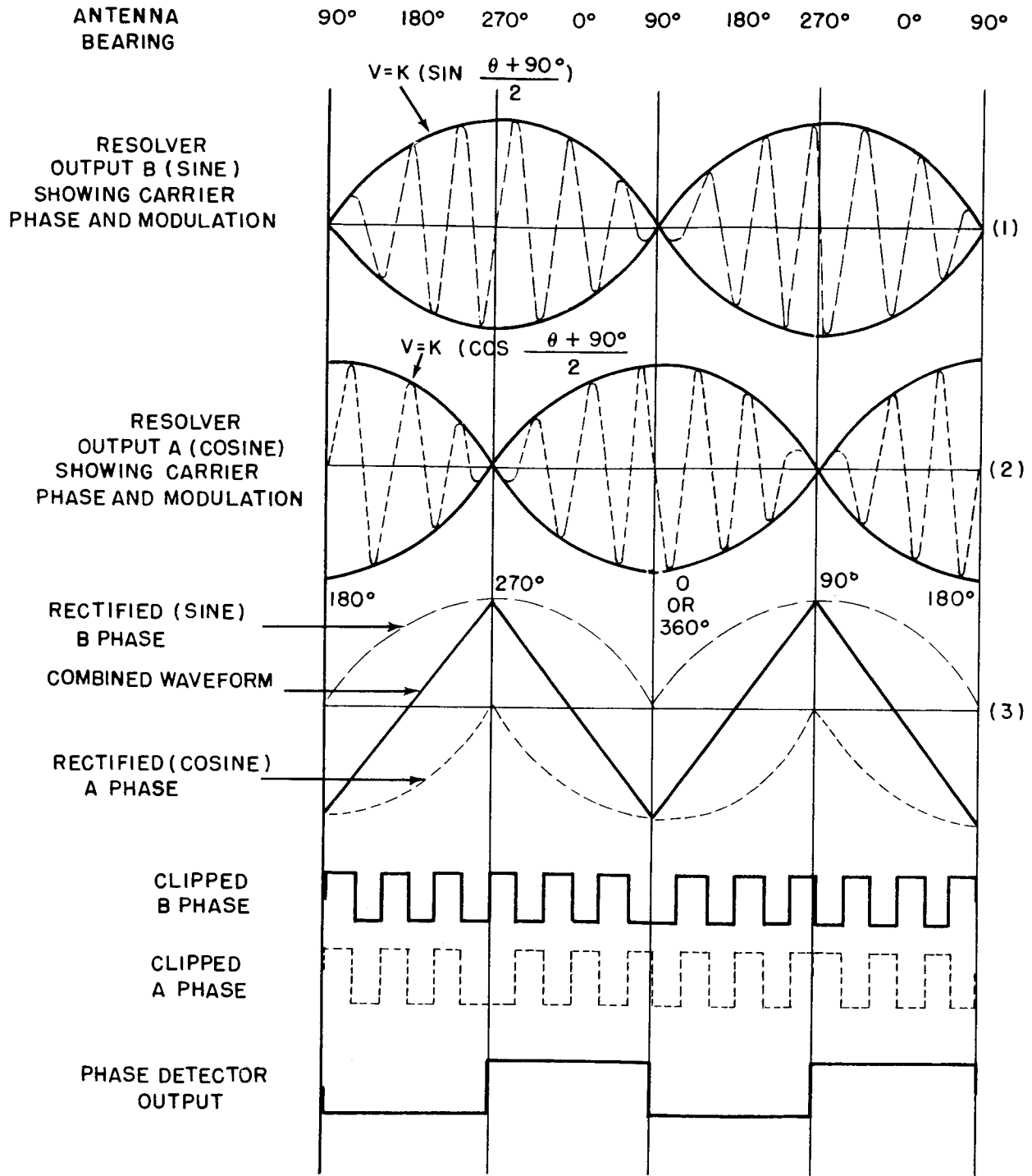

Figure 1-18.—DF horizontal deflection waveforms.

032.18

input, after being heterodyned in V10 is fed to the deflection control and amplifier stages.

When the antenna relative bearing is in the range of 270° - 0° - 90° the deflection control and amplifier stages video voltage output to the upper deflection plate of V44E is negative going. The video thus reduces the positive d-c potential on the upper V44E vertical deflection plate and the video display reflects downwards. Conversely, when the antenna relative bearing is in the range of 90° - 180° - 270° , the video voltage applied to the V44E lower vertical deflection plate is negative going. This reduces the positive voltage on the lower plate and causes an upward deflection of the electron beam when the video appears on the DF display between 90° , 180° , and 270° .

Double DF Deflection

If the repetition rate of a pulse signal is sufficiently high, pulse detection occurs in the panoramic-video circuit. The low-pass filter, FL1, removes the pulses, but a detected envelope containing the c-w signal remains and is added to the narrow video in V3 and presented via V10 on the DF display. An extra spike is caused by this detected panoramic-video signal (fig. 1-2, A). The position of this spike on the DF display varies since the panoramic circuit sweeps through the signal at different portions of the antenna pattern on successive sweeps.

The appearance of this spike is a normal occurrence with high repetition signals. To some operators the presence of the spike is objectionable and a handicap in reading the bearing. To alleviate this difficulty, the DF switch S2 allows the operator to remove the panoramic-video (narrow-band) signal by holding the switch to the NB-OFF position. A spring-return switch is used to avoid the possibility of accidentally missing a c-w intercept because the switch was left in the NB-OFF position.

DF Video Intensification

Video intensification is used on the DF display tube V44E to allow the base line to be suppressed when no incoming signal is received. A 0- to 500- μ s positive gate pulse is used in pulse combiner CR22 and CR23 to obtain intensification. The intensification pulse is initiated by the leading edge of the pulse from sweep generator V30 in the 0- to 5- μ s gate circuit and terminated by the trailing edge of the 500- μ s

gate pulse from sweep generator and amplifier V36.

To obtain intensification on c-w signals, a panoramic video signal from the low-pass filter is amplified in V3 and fed to the pulse combiner.

The output of the pulse combiner for a-m, f-m, or c-w signals is a positive pulse which is applied to the intensity (control) grid of DF display gun V44E. This pulse intensifies the DF display only when a DF video deflection signal is present.

PANORAMIC DISPLAY

The panoramic display is presented on the bottom gun of the analysis scope V44A. The horizontal voltage for V44A is supplied as a push-pull sawtooth voltage from the pan sweep amplifier (V20) in either frequency converter 1 (fig. 1-10) or frequency converter 2 (fig. 1-12). A relay in the interconnecting box (fig. 1-3) selects the signal from the proper frequency converter.

The sweep signal is applied through the contacts of reversing relay K4 (fig. 1-15) to sweep amplifier V63 and subsequently to the horizontal deflection plates of V44A. The reversing relay changes the direction (polarity) of the panoramic sweep voltage on bands 7 and 9. Sweep reversal is necessary because the local oscillator in frequency converter tuners 7 and 9 (fig. 1-3) operates below the incoming signal, whereas the local oscillator in the other tuners operates above the incoming signal. In this manner, the panoramic sweep always presents the lower frequencies to the left of center and the higher frequencies to the right.

The panoramic video signal for application to the vertical deflection plates of V44A is received from frequency converter 1 or frequency converter 2 via input jacks J7 and J6, respectively. Relay K1 selects the panoramic-video signal from the proper frequency converter. The input panoramic video signal is amplified in V1, and fed through cathode follower V2 to pulse stretcher CR19. The pulse stretcher output is amplified in panoramic vertical amplifier V62 before being applied to the vertical deflection plates of V44A.

The panoramic display is intensified only when a panoramic video signal or noise is present. A portion of the V62 output is amplified in V64 and V65 and applied to the V44A control grid as the intensifying voltage.

The Photo-Normal switch is used to reduce the appearance of noise when making time exposures.

CONTROL-STORER

The control-storer (fig. 1-14, B) contains operating controls, the tuner servoamplifier, and the storage channel system. The function of most of the controls has already been considered. The tuner servosystem automatically tunes the r-f tuner circuits (preselector and local oscillator) and the frequency indicator.

The control-storer can be operated in either of two modes, analysis or scan. During ANALYSIS operation, one of ten separate channels is selected and the operator manually tunes the receiver through the channel frequency range. During SCAN operation, a scan button on the control-storer front panel is depressed and the receiver automatically tunes through the selected channel.

Each of the ten receiver channels consists of a select button, a release button, a band indicator, a potentiometer, a magnetic clutch, and an indicator light. The circuit operation of each of the channels is the same. The circuit of the first two channel switches is shown in figure 1-19.

If the first select button is depressed, S1, S11, and S21, which are linked mechanically to this button, are closed, and a detent locks the band indicator. With these switches closed, a path is completed from the +28 volt d-c supply through S11 to ground to energize magnetic clutch E1. When the clutch energizes, the arm of potentiometer R1 is moved by the manual tune control. The voltage at the R1 arm is fed through S1 (contacts opposite to the position shown) to the tuner servoamplifier. This voltage is used in the servoamplifier to provide positioning of the tuner servomotor, which, in turn, positions the preselector and oscillator. The operation of the tuner servosystem is treated presently.

Channel Storage System

Each storage potentiometer, and its corresponding magnetic clutch, is associated with a particular select button. Only one select button (fig. 1-20, A) is depressed at a time, and therefore only the arm of the storage potentiometer associated with the depressed button moves when the manual tune control knob is rotated. The voltage at the potentiometer determines the frequency to which the receiver is tuned.

When the scan button or another select button is depressed, the arm of the storage channel potentiometer which was in use stays in the position to which it is last set. Because the

channel frequency is proportional to the potentiometer voltage the frequency to which the channel is set when another channel is selected remains stored at the potentiometer in the form of a specific value of voltage. Thus, if the signal select button is ever again depressed, the last frequency analyzed will immediately be presented.

At the time that the new select button is depressed, the band indicator detent (fig. 1-20, B) for the original channel remains engaged, and a storage channel light switch causes the band light for the original channel to continue to illuminate. The band indicator light (fig. 1-14, B) indicates that a frequency position is stored on that storage channel.

When the release button is depressed, the band indicator detent is released (as illustrated in figure 1-20, A), and rotates until it corresponds with the band in use. Also, depressing the release button disables the storage channel light switch and the band indicator light goes out.

Analysis Operation

During ANALYSIS operation (fig. 1-21) one of the select buttons is depressed and the 28-volt supply is connected to one of the magnetic clutches (depending on the selected channel). Switches K1A and K1B of scan-analysis relay K1 are in the deenergized position as shown. The potentiometer associated with the selected channel supplies the servoamplifier input which is applied to chopper G1 through the lower contacts of K1A. A triangular voltage waveform from the tuner servo potentiometer is applied through the upper K1A contacts to G1. A third voltage (6.3 vac), which serves as the reference voltage, is also applied to the chopper.

If the output voltage of the servo potentiometer is lower than the storage channel potentiometer voltage, the output from the chopper will be in phase with the 6.3-volt a-c reference voltage. After passing through cathode follower V7 and amplifier V6, the signal is shifted by 90° in a phase shift network at the grid of V5. The paraphase amplifier V4 produces two output voltages which are 180° out of phase. These out-of-phase voltages drive the push-pull amplifier comprising V3A and V3B. The resultant voltage applied to the tuner servomotor B1 via the output transformer and bridge circuit bears a 90° phase relationship with respect to the 115-volt a-c reference voltage. This phase relationship causes the motor to turn in a direction which increases the voltage of the tuner servo potentiometer. Simultaneously, the tuner

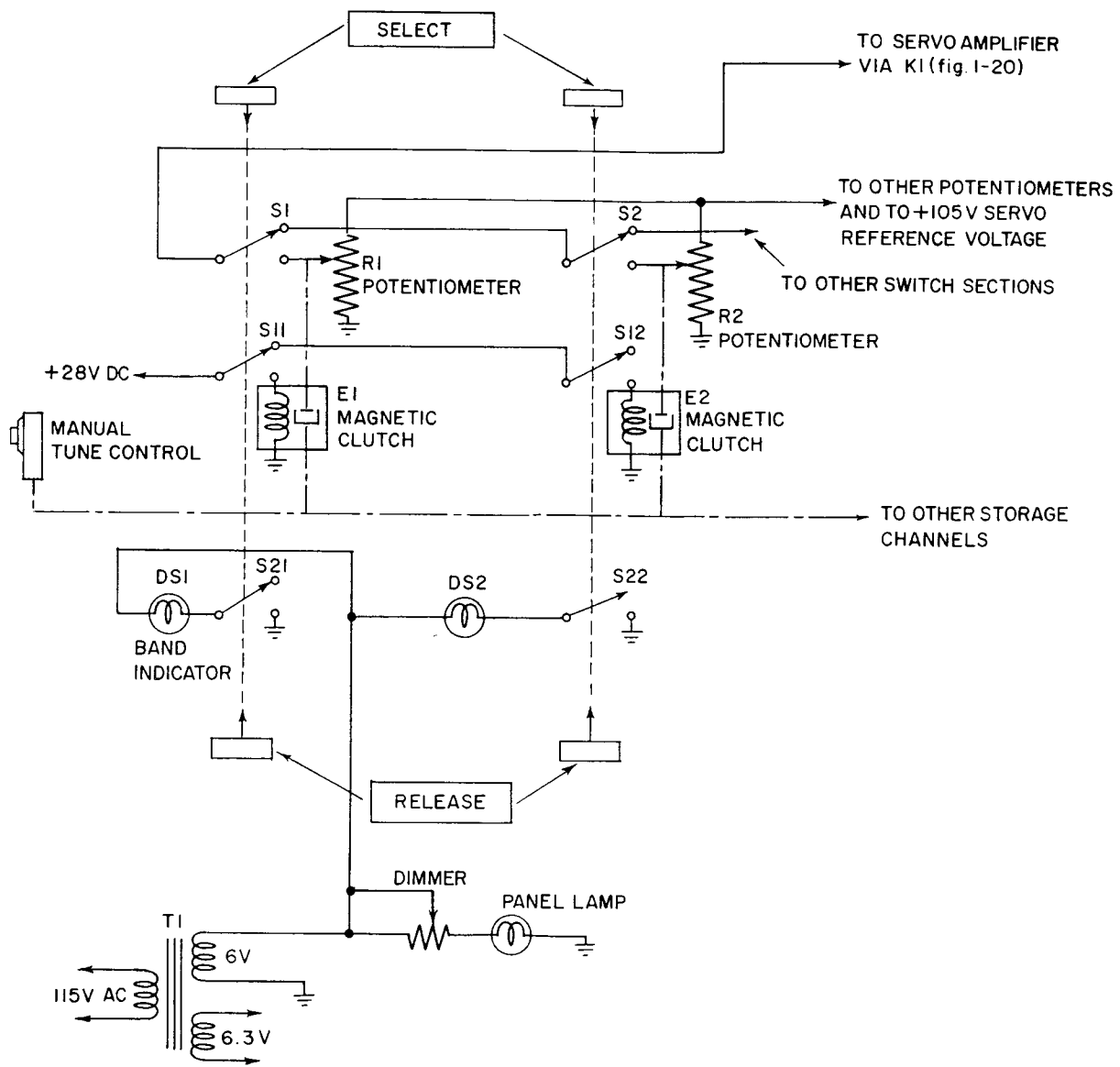

Figure 1-19.—Storage channel switches of control-storer. ^{032.19}

servomotor B1 tunes the preselector and oscillator to the frequency selected by the manual tune control.

If the voltage from the tuner servo potentiometer is greater than the voltage from the storage channel potentiometer at the chopper, the error voltage output of the chopper is 180° out of phase with the 6.3-volt a-c reference voltage. After the 90° phase shift by the phase shift network in the grid circuit of amplifier V5, the voltage applied to the tuner servomotor lags the 115-volt a-c reference voltage by 90°. This phase relationship causes the tuner servomotor

to run in the opposite direction to that described above, and the output voltage of the tuner servo potentiometer decreases. When the voltage of the tuner servo potentiometer equals the voltage of the storage channel potentiometer, there is no error voltage output from the chopper, and the motor stops.

Scan Operation

During operation with the scan button depressed, both sections of relay K1 are energized (opposite to the position shown). This action

CIRCUITRY OF SHIPBOARD ELECTRONICS EQUIPMENT

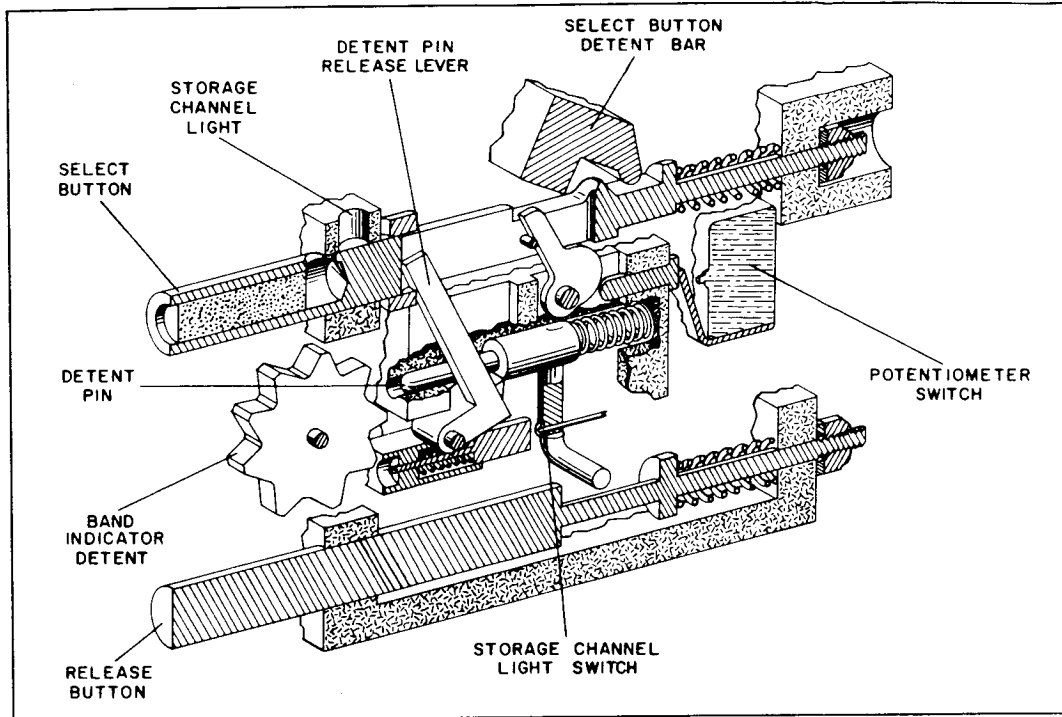

A. STORAGE CHANNEL PUSHBUTTON MECHANISM IN RELEASE POSITION

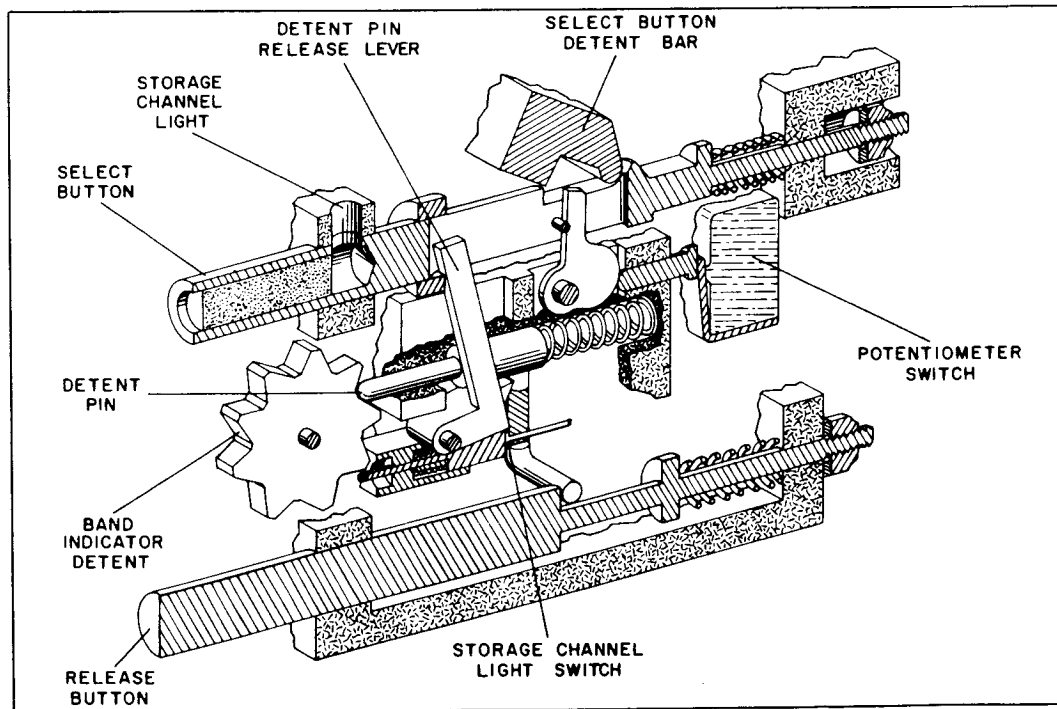

B. STORAGE CHANNEL PUSHBUTTON MECHANISM IN SELECT POSITION

Figure 1-20.—Storage channel pushbutton mechanism.

032.20

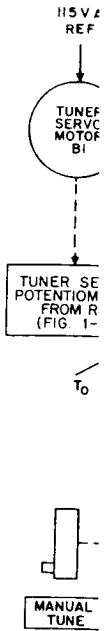

connects t
V2 through
G1.
The sec
tivibrator
its control
high and lc
With this a
the sector
input volta,
a certain p
for scan li
by a suffici

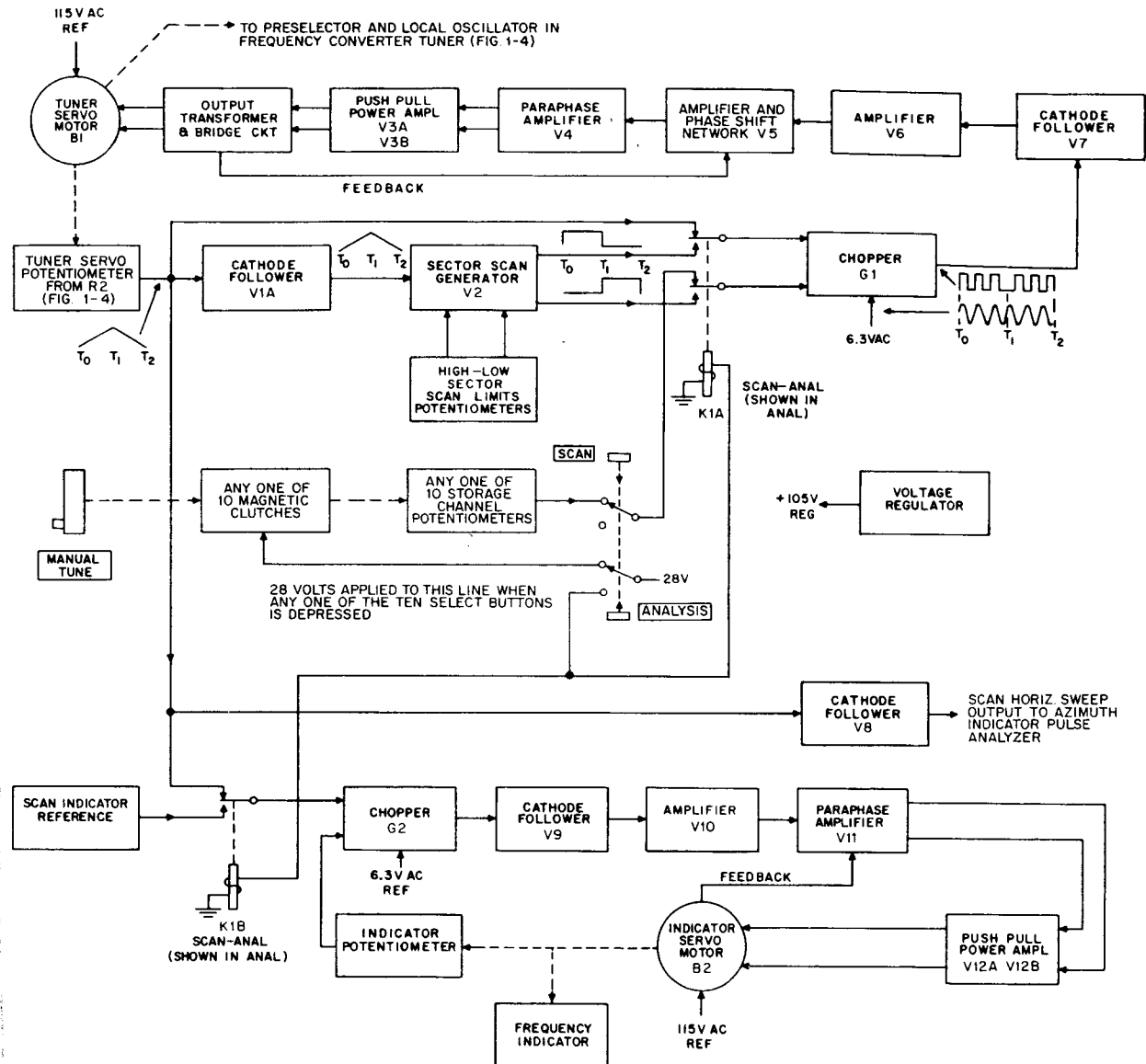

Figure 1-21.—Servosystem, block diagram. ^{032.21}

connects the output of the sector scan generator V2 through the lower K1A contacts to chopper G1.

The sector scan generator is actually a multivibrator which has the voltage limits of one of its control grids limited by the potential from high and low sector scan limit potentiometers. With this arrangement, the controlled side of the sector scan generator will conduct until the input voltage at the cathode of the tube exceeds a certain positive value with respect to the sector scan limits potentiometer voltage at the grid by a sufficient amount to cut off the controlled

side of the multivibrator. When this occurs, the alternate side of the multivibrator conducts. The sector scan generator (V2) thus produces two voltages of opposite polarity which are fed to the chopper.

Because the output of both sections of V2 are applied to the chopper G1, the input appears as a pure d-c voltage. The chopper converts the d-c output of the sector scan generator to a square wave either in phase or 180° out of phase with the 6.3-volt reference. The 6.3-volt a-c reference is in phase with the 115-volt a-c reference at the servomotor B1.

From T_0 to T_1 , the output of the chopper is in phase with the 6.3-volt a-c reference voltage applied to the chopper. The resultant square wave (at 60 cps) is fed through V7 and V6 and shifted 90° at the input to V5. The output of the push-pull amplifier is fed through the output transformer and bridge circuit to the servomotor B1. The bridge circuit provides an antihunt-feedback voltage to amplifier V5.

Because of the phase shift at the V5 grid, the 60-cps voltage from the output transformer leads the 115-volt a-c reference voltage at the servomotor by 90° . This causes the servomotor to run in a direction which increases the voltage output of the tuner servo potentiometer. The reverse is true when the 60-cps signal from the output transformer lags the 115-volt a-c reference at B1.

The voltage at the arm of the tuner servo potentiometer is applied to the sector scan generator through cathode follower V1A. The tuner servomotor (B1) continues to drive the tuner servo potentiometer arm until this voltage is greater than the voltage applied to the controlled side of V2 at T_1 . At this time, the sector scan generator reverses its output phase.

Because of the change in the V2 output, the chopper output voltage is 180° out of phase with the 6.3-volt a-c reference phase. After the phase is shifted 90° by the phase shift network, the voltage applied to the tuner servomotor lags

the 115-volt a-c references, thus causing the motor to reverse its direction of rotation. This causes the output voltage of the tuner servo potentiometer to continuously decrease until the output voltage of V1A becomes less than the voltage from the low sector scan limit potentiometer. This occurs at T_2 , and the sector scan generator again reverses its output phase to the chopper, and the cycle is completed.

Frequency Indicator

During analysis operation with one of the storage channel select buttons depressed, the frequency indicator (fig. 1-21) gives a direct digital reading of the frequency to which the receiver is tuned. The circuit operation of the frequency indicator is essentially the same as that described for the tuning servosystem. The tuner servo potentiometer provides one input to chopper G2 while an indicator potentiometer supplies the other input. Indicator servomotor B1 drives the indicator potentiometer until the voltage from the indicator potentiometer equals the voltage of the tuner servo potentiometer. When the two voltages are equal, the output of the chopper is a steady d-c voltage, and the servomotor stops. The frequency indicator is then set to the frequency of the r-f tuner in use.

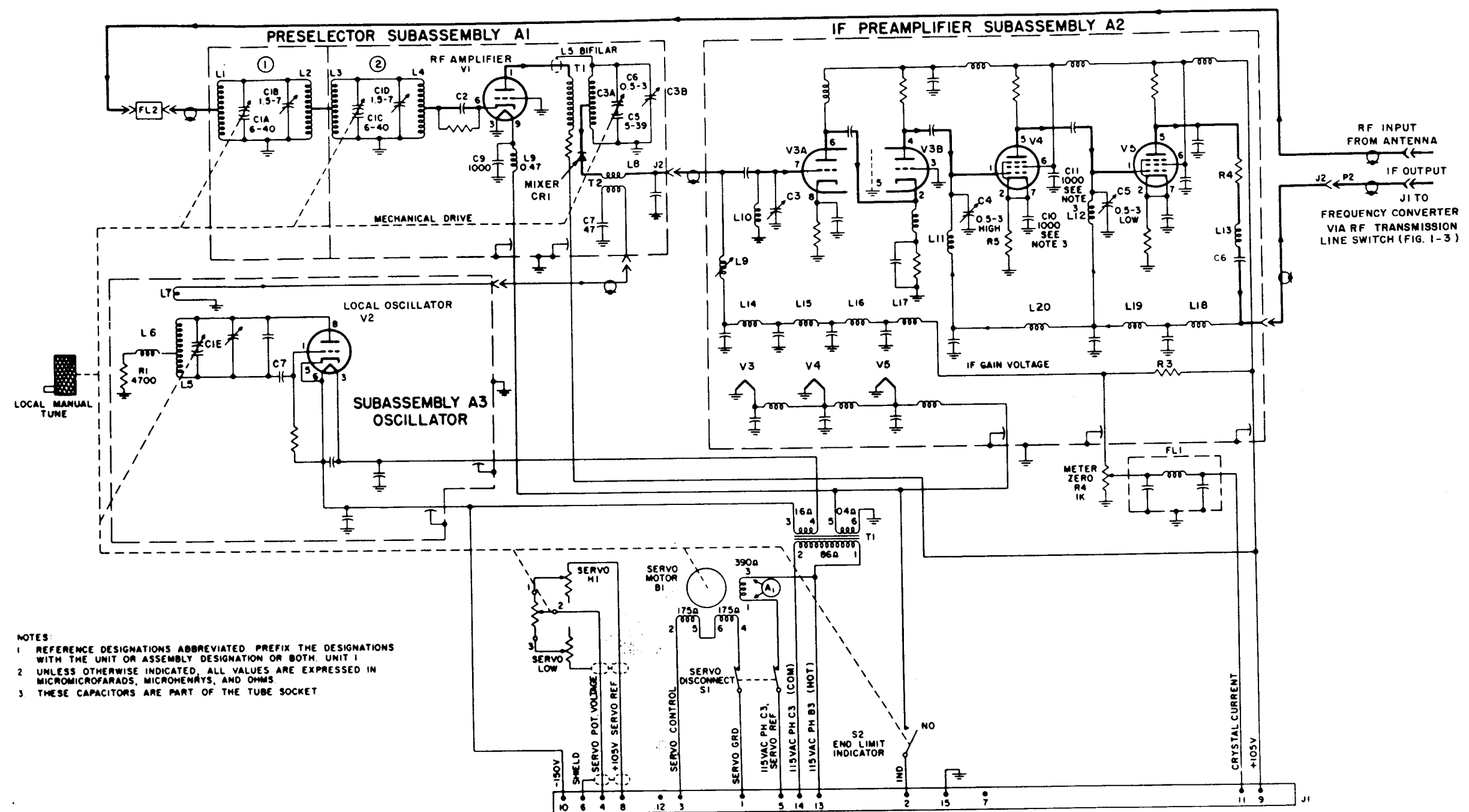
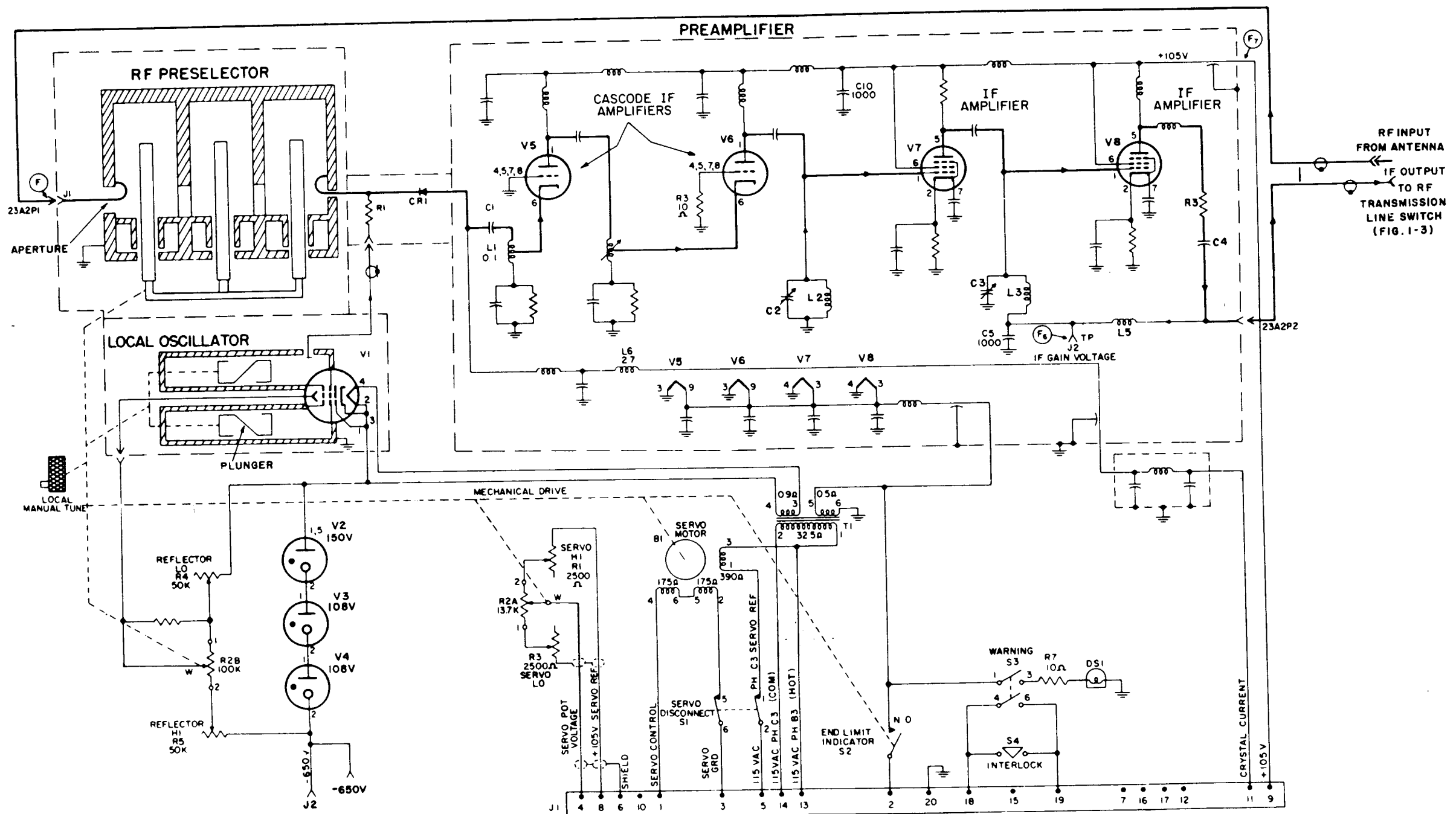

Figure 1-5.—Frequency converter tuner (low-frequency), schematic diagram.

032.5



032.7 Figure 1-7.—Frequency converter tuner (high-frequency), schematic diagram.

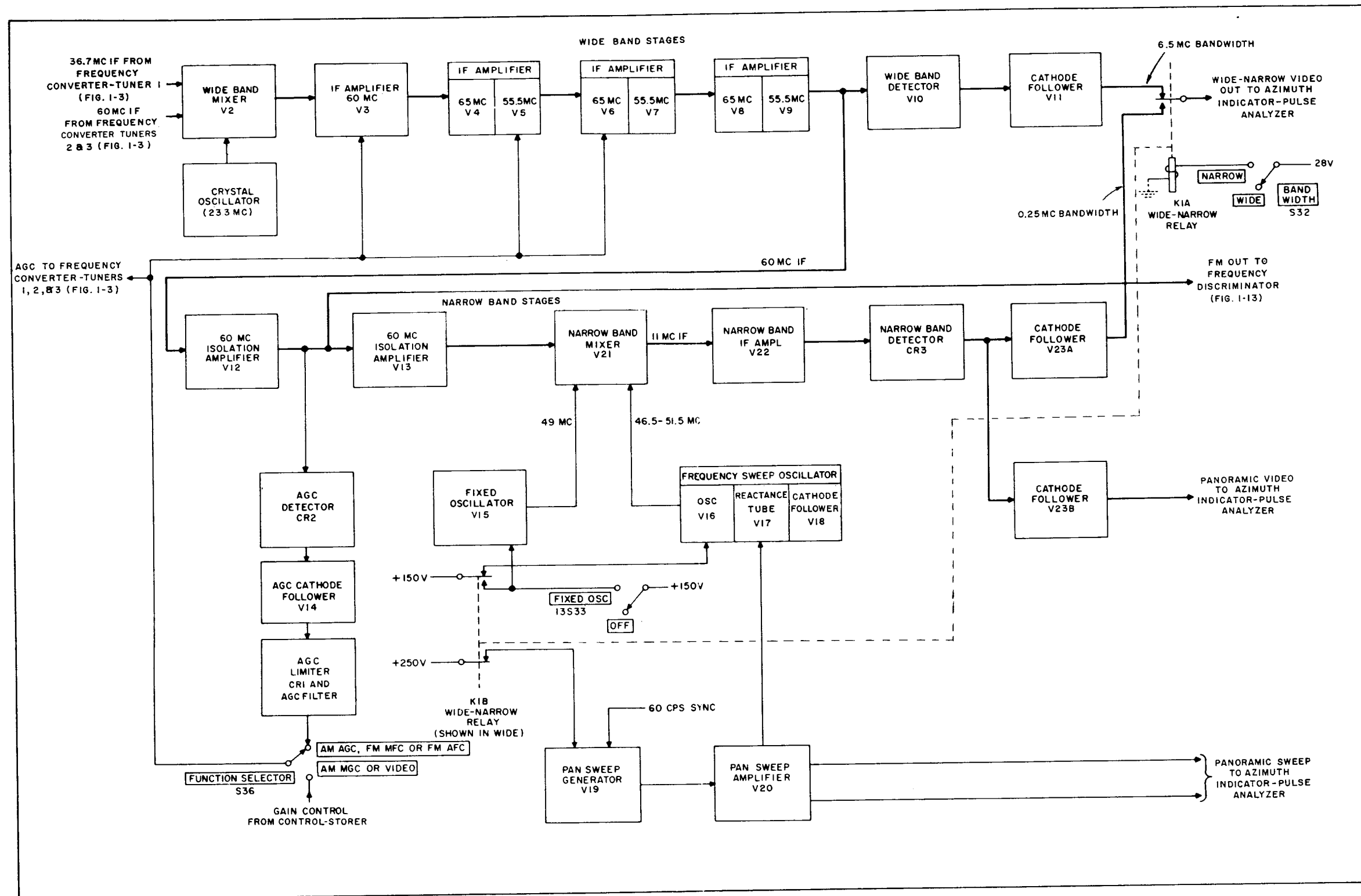

Figure 1-10.—Frequency converter 1, block diagram.

032.10

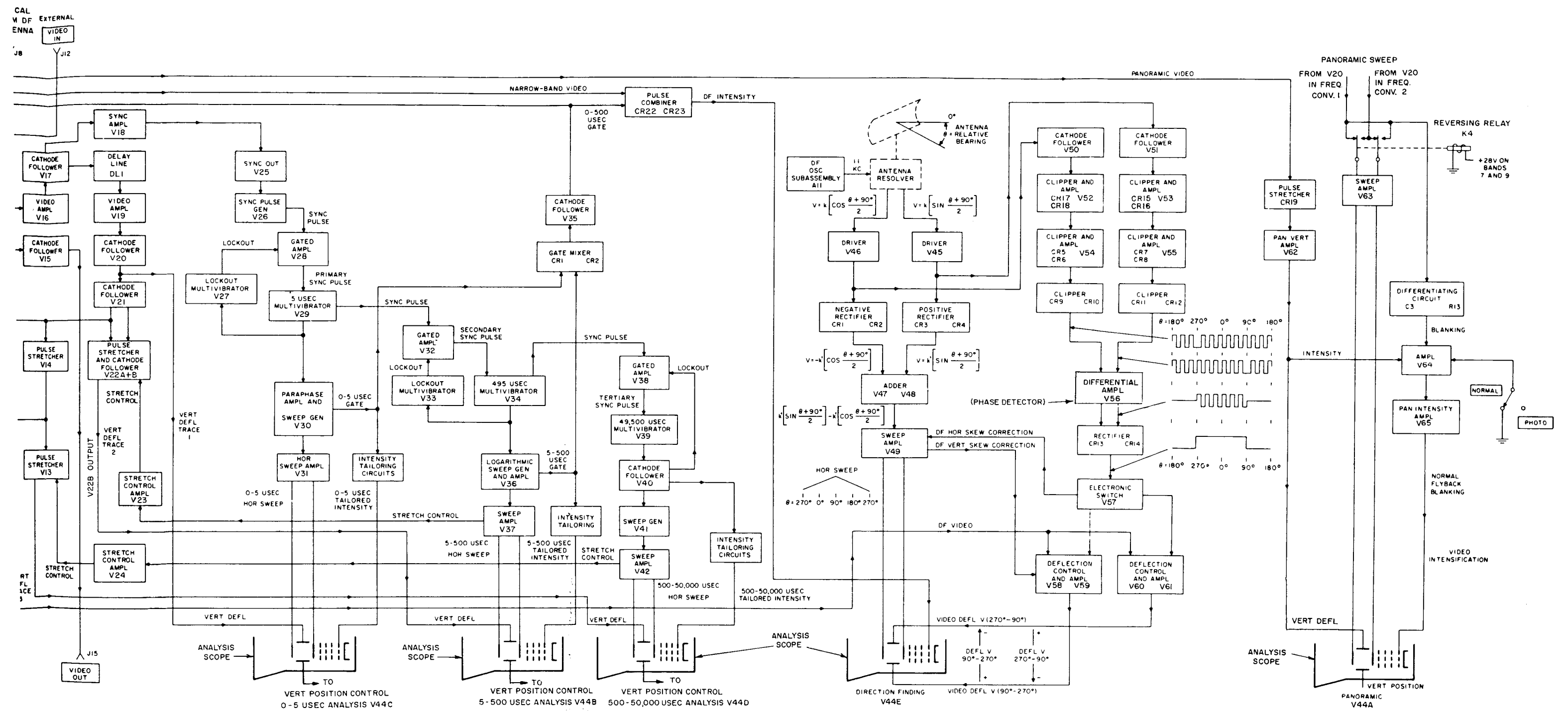

Figure 1-15.—Azimuth-indicator pulse analyzer, block diagram.

032.15

